

**TM 9-2330-390-14&P**

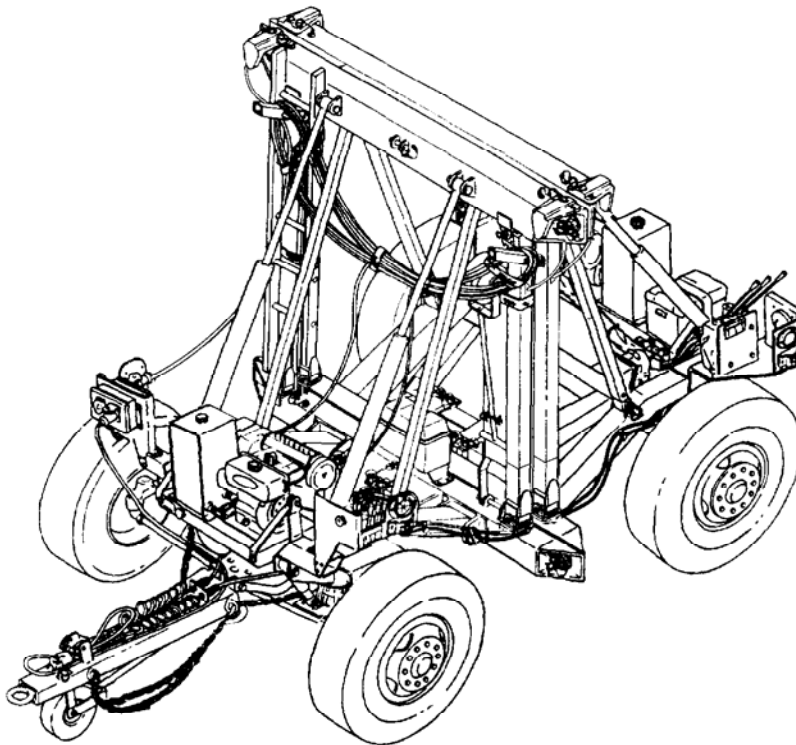
---

**TECHNICAL MANUAL**

**OPERATOR'S, UNIT, DIRECT SUPPORT,  
AND GENERAL SUPPORT MAINTENANCE MANUAL  
(INCLUDING REPAIR PARTS AND SPECIAL TOOLS LISTS)**

**FOR**

**DOLLY SET: LIFT, TRANSPORTABLE SHELTER,  
7-1/2 TON, M1022A1  
(NSN 2330-01-378-9997) (EIC: CML)**



Approved for public release; distribution is unlimited.

---

**HEADQUARTERS, DEPARTMENT OF THE ARMY**

**APRIL 1996**



FOR INFORMATION ON FIRST AID, REFER TO FM 21-11.



WARNING



**CARBON MONOXIDE (EXHAUST GASES) CAN KILL!**

Carbon monoxide is a colorless, odorless, deadly poisonous gas which, when breathed, deprives the body of oxygen and causes suffocation. Exposure to air containing carbon monoxide produces symptoms of headache, dizziness, loss of muscular control, apparent drowsiness, and coma. Permanent brain damage or death can result from severe exposure.

Carbon monoxide occurs in exhaust fumes of internal combustion engines. Carbon monoxide can become dangerously concentrated under conditions of inadequate ventilation. The following precautions must be observed to ensure safety of personnel when engine of dolly set is operated for any purpose.

- (1) DO NOT operate dolly set engine in enclosed areas. Good ventilation is essential.
- (2) BE ALERT at all times for exhaust odors.
- (3) BE ALERT for exhaust poisoning symptoms. They are:
  - Headache
  - Dizziness
  - Drowsiness
  - Loss of muscular control
- (4) If you see another person with exhaust poisoning symptoms:
  - Remove person from area.
  - Expose person to fresh air.
  - Keep person warm.
  - DO NOT permit physical exercise.
  - Administer cardiovascular pulmonary resuscitation (CPR), if necessary.
  - Notify a medic.
- (5) BE AWARE: The field protective mask for chemical-biological-radiological (CBR) protection will not protect you from carbon monoxide poisoning.

**The Best Defense Against Carbon Monoxide Poisoning Is Good Ventilation.**



### ASBESTOS HAZARD

DO NOT handle components in area of engine muffler gasket unless area has been properly cleaned. There may be asbestos dust on these components which can be dangerous if you touch it or breathe it. Wear an approved filter mask and gloves. Never use compressed air or a dry brush to clean components contaminated by asbestos. Dust may be removed using an industrial-type vacuum cleaner. Clean dust or mud away from components with water and a wet, soft brush or cloth. Failure to follow this warning may result in serious illness or death to personnel.



### BATTERY

- Remove all jewelry such as I.D. tags, rings, bracelets, etc. If jewelry contacts battery terminal, a direct short will result causing instant heating of jewelry which will result in serious injury or death to personnel.
- Battery acid (electrolyte) is extremely dangerous. Always wear protective goggles and rubber gloves when performing battery checks or inspections. Serious injury to personnel will result if battery acid contacts skin or eyes.
- DO NOT perform battery system checks or inspections while smoking or near fire, flames, or sparks. Battery gases may explode, causing serious injury or death to personnel.
- Sulfuric acid contained in batteries can cause serious burns. If battery corrosion or electrolyte makes contact with skin, eyes, or clothing, take immediate action to stop the corrosive burning effects. Failure to follow these procedures may result in serious injury or death to personnel.
  - a. Eyes. Flush with cold water for no less than 15 minutes and immediately seek medical attention.
  - b. Skin. Flush with large amounts of cold water until all acid is removed. Seek medical attention as required.
  - c. Internal. If corrosion or electrolyte is ingested, drink large amounts of water or milk. Follow with milk of magnesia, beaten egg, or vegetable oil. Immediately seek medical attention.
  - d. Clothing/Equipment. Wash area with large amounts of cold water. Neutralize acid with baking soda or household ammonia.



### BRAKE SYSTEM

- DO NOT cage spring in "spring" rear dolly airbrake chamber until wheels have been securely chocked. Once rear dolly airbrake chamber spring is caged, dolly set is without emergency/parking brakes and can roll. Failure to chock wheels may result in serious injury or death to personnel.
- DO NOT disconnect air lines and fittings while dolly set airbrake system is pressurized. Intervehicular air lines must be disconnected and air reservoirs drained before air lines and fittings are disconnected. A line or fitting disconnected under pressure may explode with great force and cause serious injury to personnel.



**CLEANING AGENTS**

- Dry cleaning solvent, P-D-680, is toxic and flammable. Always wear protective goggles and gloves, and use only in a well-ventilated area. Avoid contact with skin, eyes, and clothes, and **DO NOT** breathe vapors. **DO NOT** use near open flame or excessive heat. The solvent's flash point is 100°F-138°F (38°C-59°C). If you become dizzy while using cleaning solvent, immediately get fresh air and medical help. If solvent contacts eyes, immediately wash your eyes and seek medical attention.
- Improper cleaning methods and use of unauthorized cleaning liquids or solvents can injure personnel and damage equipment. To prevent this, refer to TM 9-247 for further instructions.



**COMPRESSED AIR**

Compressed air used for cleaning or drying purposes, or for clearing restrictions, should never exceed 30 psi (207 kPa). Wear protective clothing (goggles/shield, gloves, etc.) and use caution to avoid injury to personnel.



**DIESEL FUEL**

Diesel fuel is combustible. **DO NOT** smoke or allow open flame near fuel tank. Shut down engine when adding fuel. Failure to follow this warning will result in serious injury or death to personnel. If you are burned, immediately seek medical attention.



**ELECTRICAL SYSTEM**

When troubleshooting an electrical malfunction or performing electrical maintenance on either engine or dolly set lighting system, **ALWAYS** disconnect either battery negative (-) ground cable or intervehicular cable from towing vehicle. Failure to follow this warning may create a spark and electrical shock, resulting in serious injury to personnel.



### ENGINE

- Always wear ear plugs or other type of hearing protection while engine is running. Damage to hearing will occur without protection.
- SHUT DOWN engine before performing the following:
  - a. Checking, adjusting, or cleaning each part
  - b. Discharging, pouring, or injecting oil from or into each part
  - c. Cleaning off dust or other foreign matter from muffler or other part. Failure to follow this warning may result in serious injury to personnel.



### EXHAUST SYSTEM

DO NOT touch hot muffler or other hot pans with bare hands during or immediately after operation. Failure to follow this warning will result in serious burns.



### EYE PROTECTION

Wear eye protection (goggles/shield) when performing the following maintenance to avoid serious injury to personnel:

- a. Working under dolly set
- b. Cleaning with wire brushes and hazardous cleaning agents
- c. Striking metal parts with hammer or chisel
- d. Welding or heating dolly set components
- e. Using chisel or electric drill
- f. Using compressed air.



### HEAVY COMPONENTS

Use extreme caution when handling heavy parts. Lifting device is required when parts weigh over 50 lb (23 kg) for a single person lift, over 100 lb (45 kg) for a two person lift, and over 150 lb (68 kg) for a three or more person lift. Keep clear of heavy parts supported only by lifting device. Failure to follow this warning may cause serious injury or death to personnel.



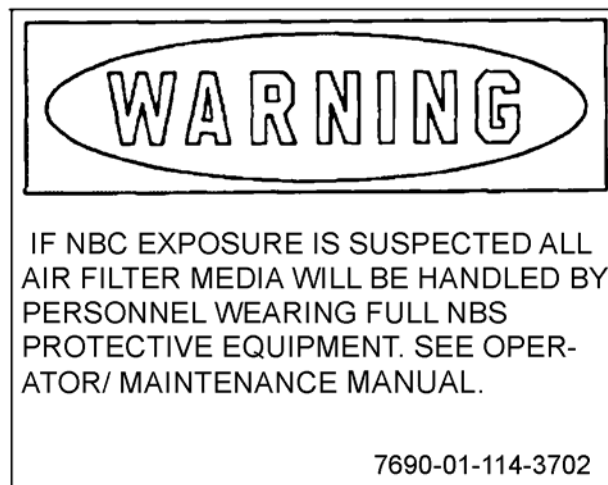
**HYDRAULIC SYSTEM**

- DO NOT disconnect hydraulic lines and fittings while engine is running or before hydraulic system pressure has been released. When engine is running, hydraulic system is under pressure. Dolly set must be fully lowered to the ground and engine must be shut down before lines and fittings are disconnected. A line or fitting disconnected under pressure will explode with great force and cause serious injury or death to personnel.
- Escaping hydraulic fluid under pressure can penetrate the skin, causing serious injury to personnel. Relieve pressure before disconnecting hydraulic lines and fittings. Tighten all connections before applying pressure. Keep hands and body away from pinholes and nozzles which eject hydraulic fluid under high pressure. Use a piece of cardboard or paper to search for leaks. If any hydraulic fluid is injected into the skin, it MUST be surgically removed within a few hours by a doctor familiar with this type of injury or gangrene may result.



**NBC EXPOSURE**

If NBC exposure is suspected, all engine air cleaner air filter media should be handled by personnel wearing protective equipment. Consult your NBC Officer or NBC NCO for appropriate handling or disposal procedures.



To order this NBC decal use:  
 National Stock Number (NSN) - 7690-01-114-3702  
 Part Number (PN) - 12296626  
 Commercial and Government Entity Code (CAGEC) - 19207



### NOISE

Always wear ear plugs or other types of hearing protection while engine is running. Damage to hearing will occur without protection.

### REDUNDANT POWER OPERATION

Redundant power kit is NOT to be used for side lift operations. Use of redundant power during side lift operations may result in unsafe operating conditions, resulting in damage to equipment or injury to personnel.



### TIRES

- NEVER reinflate a tire that has been run flat or seriously underinflated without first removing and repairing the tire and/or rim. Failure to follow this warning may result in serious injury or death to personnel.
- Before removing tire for service and disassembly of rim components, ensure that tire is COMPLETELY deflated by removing valve stem. Failure to follow this warning may result in serious injury or death to personnel.



### TOWING

- Steering locking pin MUST be removed from front axle and steering link before dolly set is towed in a four-wheel configuration. Failure to unlock steering will damage steering linkage and may result in an accident.
- DO NOT tandem tow dolly sets with shelters. To safely tow two doily sets, they must be empty. Observe a maximum towing speed of 35 mi/h (56 km/h). Failure to follow this warning may result in serious injury or death to personnel and damage to equipment.



### VEHICLE OPERATION/MOVEMENT HAZARDS

- All personnel must use caution when standing near dolly set, towing vehicle, and shelter during the following operations:
  - a. Coupling and uncoupling dolly set from towing vehicle.
  - b. Attaching and detaching front and rear dollies.
  - c. Attaching and detaching dolly halves and shelter.
  - d. Raising and lowering doily set with or without shelter.

Failure to follow this warning may cause serious injury or death to personnel.



- When dolly set is not coupled to towing vehicle, ensure that parking brakes are applied or wheels are securely chocked. Failure to do so may allow dolly set to roll, resulting in serious injury to personnel or damage to equipment.
- DO NOT operate control valve levers to put front or rear dolly in maneuvering position unless telescopic brace and front axle steering locking pin are installed. Telescopic brace and front axle steering locking pin must ALWAYS be installed before lift cylinders reach their vertical position. Failure to follow this warning may cause front or rear dolly to overturn, resulting in serious injury or death to personnel.
- Front axle steering locking pin must ALWAYS be installed for side lift operation. Failure to follow this warning may cause front or rear dolly to overturn, resulting in serious injury or death to personnel.
- While in maneuvering position, DO NOT operate positioning cylinders lever. Failure to follow this warning may cause bottom beam to lower to the ground, causing serious injury to personnel.
- Use extreme caution when climbing and working on top of shelter during side lift operations. Ensure that top of shelter is free of ice or debris which could cause slips and falls. When working with twist locks from on top of shelter, maintain a three-point contact with shelter as much as possible. When on top of shelter, always be aware of where other personnel and tools are located to prevent accidental bumps and trips. Failure to follow this warning may cause serious injury to personnel.
- Use extreme caution when removing or installing twist locks. Keep hands and/or feet clear of top hooks, top and bottom beams, and from between beams and shelter. Failure to follow this warning may cause serious injury to personnel.
- Use extreme caution when using ladder to reach top beam. Have an assistant hold ladder to ensure that it is stable. Failure to follow this warning may cause serious injury to personnel.



HEADQUARTERS  
DEPARTMENT OF THE ARMY  
Washington D.C., 30 October 2006

# OPERATOR'S, UNIT, DIRECT SUPPORT, AND GENERAL SUPPORT MAINTENANCE MANUAL (INCLUDING REPAIR PARTS AND SPECIAL TOOLS LISTS)

FOR

## DOLLY SET: LIFT, TRANSPORTABLE SHELTER, 7-1/2 TON, M1022A1 (NSN 2330-01-378-9997) (EIC: CML)

Current as of 30 October 2006

TM 9-2330-390-14&P, dated 1 April 1996, is changed as follows:

1. Remove old pages and insert new pages.
2. New or changed material is indicated by an asterisk or by a vertical bar in the margin.

<b>Remove Pages</b>	<b>Insert Pages</b>
<i>Cover</i>	<i>Cover</i>
<i>1-5 thru 1-20</i>	<i>1-5 thru 1-20</i>
<i>1-23 and 1-24</i>	<i>1-23 and 1-24</i>
<i>1-37 and 1-38</i>	<i>1-37 and 1-38</i>
<i>2-5 and 2-6</i>	<i>2-5 and 2-6</i>
<i>2-11 thru 2-22</i>	<i>2-11 thru 2-22</i>
<i>2-25 and 2-26</i>	<i>2-25 and 2-26</i>
<i>2-30.1/(2-30.2 Blank)</i>	<i>2-30.1/(2-30.2 Blank)</i>
<i>2-37 thru 2-40</i>	<i>.....2-37 thru 2-40</i>
<i>2-41 thru 2-74</i>	<i>2-41 thru 2-74</i>
<i>2-77 thru 2-98</i>	<i>2-77 thru 2-98</i>
<i>2-101 thru 2-118</i>	<i>2-101 thru 2-118</i>
<i>2-123 thru 2-128</i>	<i>2-123 thru 2-128</i>
<i>2-131 thru 2-140</i>	<i>2-131 thru 2-140</i>
<i>2-147 and 2-148</i>	<i>2-147 and 2-148</i>
<i>3-7 and 3-8</i>	<i>3-7 and 3-8</i>
<i>4-219 thru 4-232</i>	<i>4-219 thru 4-232</i>
<i>4-247 and 4-248</i>	<i>4-247 and 4-248</i>
<i>4-253 thru 4-256</i>	<i>4-253 thru 4-256</i>
<i>4-259 and 4-260</i>	<i>4-259 and 4-260</i>
<i>4-297 thru 4-302</i>	<i>4-297 thru 4-302</i>
<i>4-313 thru 4-318</i>	<i>4-313 thru 4-318</i>
<i>4-321 and 4-322</i>	<i>4-321 and 4-322</i>
<i>5-1 and 5-2</i>	<i>5-1 and 5-2</i>
<i>5-9 thru 5-14</i>	<i>5-9 thru 5-14</i>
<i>5-33 and 5-34</i>	<i>5-33 and 5-34</i>
<i>19-1 thru Figure 21</i>	<i>19-1 thru Figure 21</i>
<i>26-1 thru Figure 28</i>	<i>26-1 thru Figure 28</i>
<i>l-1 thru l-20</i>	<i>l-1 thru l-20</i>
<i>l-23 thru l-42</i>	<i>l-23 thru l-42</i>
<i>DA Forms 2028-2</i>	<i>DA Forms 2028</i>

3. File this change sheet in front of the publication for reference purposes.

**Approved for public release; distribution is unlimited.**

TM 9-2330-390-14&P  
C5

By Order of the Secretary of the Army:

PETER J. SCHOOMAKER  
*General, United States Army*  
*Chief of Staff*

Official:

A handwritten signature in black ink that reads "Joyce E. Morrow". The signature is written in a cursive style with a large initial "J" and "M".

JOYCE E. MORROW  
Administrative Assistant to the  
Secretary of the Army  
0627107

Distribution:

DISTRIBUTION: To be distributed in accordance with initial distribution number (IDN) 391016, requirements for TM 9-2330-390-14&P.

CHANGE  
No. 4

HEADQUARTERS  
DEPARTMENT OF THE ARMY  
Washington D.C., 1 November 2000

**OPERATOR'S, UNIT, DIRECT SUPPORT, AND GENERAL SUPPORT MAINTENANCE  
MANUAL (INCLUDING REPAIR PARTS AND SPECIAL TOOLS LISTS)**

FOR

**DOLLY SET: LIFT, TRANSPORTABLE SHELTER, 7-1/2 TON, M1022A1  
(NSN 2330-01-378-9997) (EIC: CML)**

Current as of 10 August 2000

TM 9-2330-390-14&P, dated April 1996, is changed as follows:

1. Remove old pages and insert new pages.
2. New or changed material is indicated by an asterisk or by a vertical bar in the margin.

**Remove Pages**

*v and vi*  
2-13 thru 2-16  
2-19 and 2-20  
4-79 and 4-80  
4-141 and 4-142  
4-161 thru 4-164  
4-167 thru 4-170  
4-197 and 4-198  
4-209/(4-210 Blank)  
4-229 thru 4-232  
4-239 thru 4-250  
4-263/(4-264 Blank)  
4-269 thru 4-274  
4-307 thru 4-310  
4-329 and 4-330  
4-401 and 4-402  
5-33 and 5-34  
5-37 thru 5-48  
B-3 thru B-6  
Appendix C, 1-1 thru 55-1  
I-1 thru I-27  
D-1 and D-2  
F-1 and F-2  
F-5/(F-6 Blank)

**Insert Pages**

*A and B*  
*v and vi*  
2-13 thru 2-16  
2-19 and 2-20  
4-79 and 4-80  
4-141 and 4-142  
4-161 thru 4-164  
4-167 thru 4-170  
4-197 and 4-198  
4-209/(4-210 Blank)  
4-229 thru 4-232  
4-239 thru 4-250  
4-263/(4-264 Blank)  
4-269 thru 4-274  
4-307 thru 4-310  
4-329 and 4-330  
4-401 and 4-402  
5-33 and 5-34  
5-37 thru 5-48  
B-3 thru B-6  
Appendix C, 1-1 thru 55-1  
I-1 thru I-42  
D-1 and D-2  
F-1 and F-2  
F-5/(F-6 Blank)

3. File this change sheet in front of the publication for reference purposes.

Approved for public release; distribution is unlimited.

TM 9-2330-390-14&P  
C4

By Order of the Secretary of the Army:

ERIC K. SHINSEKI  
*General, United States Army*  
*Chief of Staff*

Official:



JOEL B. HUDSON  
*Administrative Assistant to the*  
*Secretary of the Army*  
05917

DISTRIBUTION: To be distributed in accordance with the initial distribution requirements for IDN 391016, requirements for TM 9-2330-390-14&P.

CHANGE

No. 3

HEADQUARTERS  
DEPARTMENT OF THE ARMY  
Washington D.C., 27 April 1998

**OPERATOR'S, UNIT, DIRECT SUPPORT, AND GENERAL SUPPORT MAINTENANCE  
MANUAL (INCLUDING REPAIR PARTS AND SPECIAL TOOLS LISTS)**

**FOR**

**DOLLY SET: LIFT, TRANSPORTABLE SHELTER, 7-1/2 TON, M1022A1**

**(NSN 2330-01-378-9997) (EIC: CML)**

Current as of 27 August 1997

TM 9-2330-390-14&P, dated 1 April 1996, is changed as follows:

1. Remove old pages and insert new pages.
2. New or changed material is indicated by an asterisk or by a vertical bar in the margin.

**NOTE**

There was a page numbering error in Change 1 which resulted in two sets of pages 4-401 thru 4-405/(4-406 Blank) - each set containing different information. To correct this page numbering error, remove both sets of 4-401 thru 4-405/(4-406 Blank) and insert 4-400.1 thru 4-400.5/(4-400.6 Blank) and 4-401 thru 4-405/(4-406 Blank) as indicated in the remove and insert instructions below.

**Remove Pages**

v and vi  
2-37 and 2-38  
4-25 and 4-26  
4-113 thru 4-116  
4-197 and 4-198  
4-217 thru 4-226  
4-269 thru 4-272  
4-395 and 4-396  
4-401 thru 4-405/(4-406 Blank)  
5-3 and 5-4  
5-11 and 5-12  
19-1 and Figure 20  
20-1 and 20-2  
1-1 thru 1-27  
Index 7 and Index 8  
Index 17 and Index 18

**Insert Pages**

V and vi  
2-30.1/(2-30.2 Blank)  
2-37 and 2-37.0  
2-37.1 and 2-38  
4-25 and 4-26  
4-113 thru 4-116  
4-197 and 4-198  
4-217 thru 4-226  
4-269 thru 4-272  
4-395 and 4-396  
4-400.1 thru 4-400.5/(4-400.6 Blank)  
4-401 thru 4-405/(4-406 Blank)  
5-3 and 5-4  
5-11 and 5-12  
19-1 and Figure 20  
20-1 and 20-2  
1-1 thru 1-27  
Index 7 and Index 8  
Index 17 and Index 18

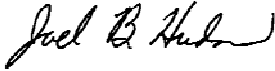
3. File this change sheet in front of the publication for reference purposes.

Approved for public release; distribution is unlimited.

By Order of the Secretary of the Army:

DENNIS J. REIMER  
*General, United States Army*  
*Chief of Staff*

Official:



JOEL B. HUDSON  
*Administrative Assistant to the*  
*Secretary of the Army*  
04652

DISTRIBUTION: To be distributed in accordance with the initial distribution for IDN 391016, requirements for TM 9-2330-390-14&P.



CHANGE  
NO. 2

HEADQUARTERS  
DEPARTMENT OF THE ARMY  
Washington D.C., 13 May 1997

**OPERATOR'S, UNIT, DIRECT SUPPORT, AND GENERAL SUPPORT MAINTENANCE  
MANUAL (INCLUDING REPAIR PARTS AND SPECIAL TOOLS LISTS)**

FOR

**DOLLY SET: LIFT, TRANSPORTABLE SHELTER, 7-1/2 TON, M1022A1**

**(NSN 2330-01-378-9997) (EIC: CML)**

Current as of 3 February 1997

TM 9-2330-390-14&P, dated April 1996, is changed as follows:

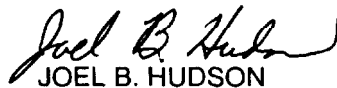
1. Remove old pages and insert new pages.
2. New or changed material is indicated by an asterisk or by a vertical bar in the margin.

Remove Pages	Insert Pages
1-25 and 1-26	1-25 and 1-26
4-197 and 4-198	4-197 and 4-198
4-239 thru 4-242	4-239 thru 4-242
B-5 and B-6	B-5 and B-6
17-1 and Figure 18	17-1 and Figure 18
18-1 and Figure 19	18-1 and Figure 19
51-1 and Figure 52	51-1 and Figure 52
I-1 thru I-27	I-1 thru I-27

3. File this change sheet in front of the publication for reference purposes.

By Order of the Secretary of the Army:

Official:

  
JOEL B. HUDSON

Administrative Assisfant to the  
Secretary of the Army  
03539

**DENNIS J. REIMER**  
General, United States Army  
Chief of Staff

DISTRIBUTION:

To be distributed in accordance with the initial distribution number (IDN) 391016, requirements for TM 9-2330-390-14&P.

Approved for public release; distribution is unlimited.

CHANGE

NO. 1

HEADQUARTERS  
DEPARTMENT OF THE ARMY  
Washington D.C., 1 August 1996

**OPERATOR'S, UNIT, DIRECT SUPPORT, AND GENERAL SUPPORT MAINTENANCE  
MANUAL (INCLUDING REPAIR PARTS AND SPECIAL TOOLS LISTS)**

**FOR**

**DOLLY SET: LIFT, TRANSPORTABLE SHELTER, 7-1/2 TON, M1022A1**

**(NSN 2330-01-379-9997) (EIC: CML)**

Current as of 1 August 1996

TM 9-2330-390-14&P, dated April 1996, is changed as follows:

1. Remove old pages and Insert new pages.
2. New or changed material Is indicated by an asterisk or by a vertical bar In the margin.

Remove Pages	Insert Pages
v and vi	v and vi
1-5 and 1-6	1-5 and 1-6
2-25 and 2-26	2-25 and 2-26
2-143 and 2-144	2-143 and 2-144
	2-144.1 and 2-144.2
2-145 and 2-146	2-145 and 2-146
4-219 thru 4-222	4-219 thru 4-222
4-255 and 4-256	4-255 and 4-256
4-259 and 4-260	4-259 and 4-260
4-297 thru 4-300	4-297 thru 4-300
4-305 and 4-306	4-305 and 4-306
4-311 and 4-312	4-311 and 4-312
4-395 and 4-396	4-395 and 4-396
4-399/(4-400 Blank)	4-399 thru 4-404
	4-405/(4-406 Blank)
5-9 and 5-10	5-9 and 5-10
5-13 and 5-14	5-13 and 5-14
B-7 and B-8	B-7 and B-8
30-1 and 30-2	30-1 and 30-2
54-1	54-1 and Figure 54A
	54A-1
55-1	55-1
I-1 thru I-24	I-1 thru I-27
E-1/(E-2 Blank)	E-1/(E-2 Blank)
Index 3 and Index 4	Index 3 and Index 4
Index 7 and Index 8	Index 7 and Index 8
Index 11 and Index 12	Index 11 and Index 12
Index 17 and Index 18	Index 17 and Index 18

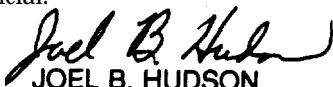
3. File this change sheet in front of the publication for reference purposes.

Approved for public release; distribution is unlimited.

By Order of the Secretary of the Army:

**DENNIS J. REIMER**  
*General, United States Army*  
*Chief of Staff*

Official:

  
**JOEL B. HUDSON**  
*Administrative Assistant to the*  
*Secretary of the Army*  
02787

DISTRIBUTION:

To be distributed in accordance with the initial distribution number number (IDN) 391016, requirements for TM 9-2330-390-14&P.

**LIST OF EFFECTIVE PAGES**

**NOTE**

A vertical line in the outer margins of the page indicates the portion of text affected by the change. Changes to illustrations are indicated by miniature pointing hands. Change to wiring diagrams is indicated by shaded areas.

Dates of issue for original and change pages are:

Original	0	1 April 1996
Change	1	1 August 1996
Change	2	13 May 1997
Change	3	27 April 1998
Change	4	1 November 2000
Change	5	30.October.2006

TOTAL NUMBER OF PAGES IN THIS PUBLICATION IS 948 CONSISTING OF THE FOLLOWING:

<b>Page No.</b>	<b>*Change No.</b>	<b>Page No.</b>	<b>*Change No.</b>
Cover (Back Blank)	5	2-25	5
a thru g/(h Blank)	0	2-26	1
A and B	5	2-27 thru 2-30	0
i thru iv	0	2-30.1/(2-30.2 Blank)	5
v	1	2-31 thru 2-37	0
vi	4	2-37.0	5
vii thru ix (x Blank)	0	2-37.1	3
Blank and 1-0	5	2-38 thru 2-41	0
1-1 thru 1-4	0	2-42 and 2-43	5
1-5	1	2-44 and 2-45	0
1-6	5	2-46	5
1-7	0	2-47	0
1-8 thru 1-10	5	2-48 thru 2-65	5
1-11	0	2-66	0
1-12 thru 1-15	5	2-67 thru 2-74	5
1-16 and 1-17	0	2-75 and 2-76	0
1-18 thru 1-20	5	2-77 thru 2-80	5
1-21 thru 1-23	0	2-81	0
1-24	5	2-82 and 2-83	5
1-25	0	2-84	0
1-26	2	2-85 thru 2-89	5
1-27 thru 1-36	0	2-90 and 2-91	0
1-37 and 1-38	5	2-92 thru 2-96	5
1-39 thru 1-43/(1-44 Blank)	0	2-97	0
2-1 thru 2-4	0	2-98	5
2-5	5	2-99 and 2-100	0
2-6 thru 2-10	0	2-101 thru 2-104	5
2-11	5	2-105	0
2-12 and 2-13	0	2-106 thru 2-110	5
2-14 and 2-15	5	2-111	0
2-16 and 2-17	0	2-112 thru 2-118	5
2-18	5	2-119 thru 2-122	0
2-19	0	2-123	5
2-20 and 2-21	5	2-124 and 2-125	0
2-22	0	2-126 thru 2-128	5
2-23 and 2-24	0	2-129 and 2-130	0

**TM 9-2330-390-14&P**  
**C5**

<b>Page No.</b>	<b>*Change No.</b>	<b>Page No.</b>	<b>*Change No.</b>
2-131 thru 2-139	5	4-300	5
2-140 thru 2-143	0	4-301	0
2-144 thru 2-145	1	4-302	5
2-146	0	4-303 and 4-304	0
2-147 and 2-148	5	4-305	1
2-149 thru 2-153/(2-154 Blank)	0	4-306 and 4-307	0
3-1 thru 3-6	0	4-308 and 4-309	4
3-7	5	4-310	0
3-8 thru 3-29/(3-30 Blank)	0	4-311	1
4-1 thru 4-24	0	4-312	0
4-25	3	4-313 and 4-314	5
4-26 thru 4-79	0	4-315	0
4-80	4	4-316	5
4-81 thru 4-113	0	4-317	0
4-114 and 4-115	3	4-318	5
4-116 thru 4-140	0	4-319 and 4-320	0
4-141 and 4-142	4	4-321 and 4-322	5
4-143 thru 4-161	0	4-323 thru 4-328	0
4-162 and 4-163	4	4-329 and 4-330	4
4-164 thru 4-166	0	4-331 thru 4-394	0
4-167	4	4-395	3
4-168	0	4-396 thru 4-398	0
4-169	4	4-399 and 4-400	1
4-170 thru 4-196	0	4-400.1 thru 4-400.5 (4-400.6 Blank)	3
4-197	4	4-401	3
4-198	2	4-402	4
4-199 thru 4-208	0	4-403 thru 4-405/(4-406 Blank)	3
4-209/(4-210 Blank)	4	5-1	0
4-211 thru 4-217	0	5-2	5
4-218	3	5-3	3
4-219 thru 4-228	5	5-4 thru 5-8	0
4-229	4	5-9 and 5-10	5
4-230	5	5-11	0
4-231	4	5-12	5
4-232	5	5-13	0
4-233 thru 4-238	0	5-14	5
4-239	2	5-15 thru 5-32	0
4-240 thru 4-246	4	5-33	5
4-247	5	5-34	4
4-248 and 2-249	4	5-35 thru 5-37	0
4-250 thru 4-252	0	5-38 thru 5-47	4
4-253/(4-254 Blank)	5	5-48 thru 5-52	0
4-255	0	A-1 and A-2	0
4-256	5	B-1 thru B-3	0
4-257 and 4-258	0	B-4	4
4-259	5	B-5	0
4-260 and 4-261/(4-262 Blank)	0	B-6	4
4-263/(4-264 Blank)	4	B-7	0
4-265 thru 4-268	0	B-8	1
4-269 thru 4-273	4	B-9/(B-10 Blank)	0
4-274 thru 4-296	0	C-1 thru C-7	0
4-297 and 4-298	5	Appendix C, Figure 1	0
4-299	1	Appendix C, 1-1 thru 19-1	4

<b>Page No.</b>	<b>*Change No.</b>	<b>Page No.</b>	<b>*Change No.</b>
Appendix C, Figure 20 thru 20-3	5	F-3 and F-4	0
Appendix C, Figure 21 thru 26-1	4	F-5/(F-6 Blank)	4
Appendix C, Figure 27 and 27-1	5	G-1 thru G-4	0
Appendix C, Figure 28 thru 55-1	4	H-1 thru H-3/(H-4 Blank)	0
Appendix C, I-1 thru I-20	5	Index 1 thru Index 3	0
Appendix I-21 thru I-23	4	Index 4	1
Appendix C, I-24 thru I-41/(I-42 Blank)	5	Index 5 and Index 6	0
D-1	0	Index 7	3
D-2	4	Index 8 thru Index 10	0
D-3/(D-4 Blank)	0	Index 11	1
E-1/(E-2 Blank)	1	Index 12 thru Index 17	0
F-1	0	Index 18	3
F-2	4	Index 19 and Index 20	0

\*Zero in this column indicates an original page.



TECHNICAL MANUAL

TM 9-2330-390-14&P

HEADQUARTERS  
DEPARTMENT OF THE ARMY  
Washington, D.C., 1 April 1996

**OPERATOR'S, UNIT, DIRECT SUPPORT, AND  
GENERAL SUPPORT MAINTENANCE MANUAL  
(INCLUDING REPAIR PARTS AND SPECIAL TOOLS LISTS)**

FOR

**DOLLY SET: LIFT, TRANSPORTABLE SHELTER,  
7-1/2 TON, M1022A1  
(NSN 2330-01-378-9997) (EIC: CML)**

Current as of 22 March 1996

Approved for public release; distribution is unlimited.

**REPORTING ERRORS AND RECOMMENDING IMPROVEMENTS**

You can help improve this manual. If you find any mistakes or if you know of a way to improve the procedures, please let us know. Mail your letter or DA Form 2028 (Recommended Changes to Publications and Blank Forms), direct to: Commander, U.S. Army Tank-Automotive and Armaments Command, Attn: AMSTA-LC-LPIT/Tech Pubs, 1 Rock Island Arsenal, Rock Island, IL 61299-7630. A reply will be furnished to you.

You may also provide DA Form 2028 information to TACOM via datafax or e-mail.

- TACOM's fax number is: DSN 793-0726
- TACOM's e-mail address is: [tacom-tech-pubs@ria.army.mil](mailto:tacom-tech-pubs@ria.army.mil)

**TABLE OF CONTENTS**

	Page
How To Use This Manual . . . . .	vii
<b>CHAPTER 1 INTRODUCTION</b>	
Section I.    General Information . . . . .	1-1
Section II.   Equipment Description and Data . . . . .	1-4
Section III.  Principles of Operation . . . . .	1-30
<b>CHAPTER 2 OPERATING INSTRUCTIONS</b>	
Section I.    Description and Use of Operator's Controls and Indicators . . . . .	2-1
Section II.   Operator/Crew Preventive Maintenance Checks and Services (PMCS) . . . . .	2-8
Section III.  Operation Under Usual Conditions . . . . .	2-44
Section IV.   Operation Under Unusual Conditions . . . . .	2-143



## TABLE OF CONTENTS (Con't)

		Page
<b>CHAPTER 3 OPERATOR/CREW MAINTENANCE</b>		
Section I.	Lubrication Instructions . . . . .	3-1
Section II.	Operator/Crew Troubleshooting Procedures . . . . .	3-9
Section III.	Operator/Crew Maintenance . . . . .	3-20
<b>CHAPTER 4 UNIT MAINTENANCE</b>		
Section I.	Repair Parts; Special Tools; Test, Measurement, and Diagnostic Equipment (TMDE); and Support Equipment . . . . .	4-1
Section II.	Service Upon Receipt . . . . .	4-2
Section III.	General Maintenance Instructions . . . . .	4-4
Section IV.	Unit Preventive Maintenance Checks and Services (PMCS) . . . . .	4-16
Section V.	Unit Troubleshooting Procedures . . . . .	4-26
Section VI.	Electrical System Maintenance . . . . .	4-47
Section VII.	Front Axle Assembly Maintenance . . . . .	4-111
Section VIII.	Brake System Maintenance . . . . .	4-121
Section IX.	Wheel, Brakedrum, and Tire Maintenance . . . . .	4-191
Section X.	Steering Maintenance . . . . .	4-201
Section XI.	Frame and Towing Attachments Maintenance . . . . .	4-211
Section XII.	Springs and Shock Absorbers Maintenance . . . . .	4-255
Section XIII.	Body Maintenance . . . . .	4-263
Section XIV.	Accessory Items Maintenance . . . . .	4-265
Section XV.	Hydraulic System Maintenance . . . . .	4-269
Section XVI.	Engine Maintenance . . . . .	4-327
Section XVII.	Special Purpose Kits Maintenance . . . . .	4-395
Section XVIII.	Preparation for Storage or Shipment . . . . .	4-401
<b>CHAPTER 5 DIRECT SUPPORT AND GENERAL SUPPORT MAINTENANCE</b>		
Section I.	Front and Rear Axle Assemblies Maintenance . . . . .	5-1
Section II.	Brakedrum and Tire Maintenance . . . . .	5-7
Section III.	Frame Maintenance . . . . .	5-9
Section IV.	Hydraulic System Maintenance . . . . .	5-15
Section V.	Special Purpose Kits Maintenance . . . . .	5-31

## TABLE OF CONTENTS (Con't)

	Illus/ Fig	Page
<b>APPENDIX A REFERENCES</b> .....		A-1
<b>APPENDIX B MAINTENANCE ALLOCATION CHART (MAC)</b> .....		B-1
<b>APPENDIX C REPAIR PARTS AND SPECIAL TOOLS LISTS (RPSTL)</b> .....		C-1
Section I.    Introduction .....		C-1
Section II.   Repair Parts List .....		1-1
GROUP 06   ELECTRICAL SYSTEM		
0608 - MISCELLANEOUS ITEMS .....		1-1
FORWARD JUNCTION BOX .....	1	1-1
SIGNAL CONDITIONING BOX .....	2	2-1
REAR JUNCTION BOX .....	3	3-1
0609 - LIGHTS .....		4-1
MARKER CLEARANCE LIGHT ASSEMBLY .....	4	4-1
TAILLIGHT ASSEMBLY .....	5	5-1
IDENTIFICATION LIGHT ASSEMBLY .....	6	6-1
0612 - BATTERIES, STORAGE .....		7-1
BATTERY AND CASE .....	7	7-1
0613 - HULL OR CHASSIS WIRING HARNESS .....		8-1
INTERCONNECTING CABLES .....	8	8-1
GROUP 10   FRONT AXLE		
1000 - FRONT AXLE ASSEMBLY .....		4-1
FRONT AXLE .....	9	4-1
1004 - STEERING AND LEANING WHEEL MECHANISM .....		10-1
STEERING KNUCKLE ASSEMBLY .....	10	10-1
GROUP 11   REAR AXLE		
1100 - REAR AXLE ASSEMBLY .....		11-1
REAR AXLE .....	11	11-1
GROUP 12   BRAKES		
1202 - SERVICE BRAKES .....		12-1
SERVICE BRAKES .....	12	12-1
1208 - AIRBRAKE SYSTEM .....		13-1
AIRBRAKE VALVES, LINES, AND FITTINGS, FRONT .....	13	13-1
AIRBRAKE CHAMBER AND LINES, FRONT .....	14	14-1
AIRBRAKE CHAMBERS, LINES, AND FITTINGS, REAR .....	15	15-1
AIRBRAKE RELAY VALVES, LINES, AND FITTINGS, REAR .....	16	16-1
GROUP 13   WHEELS AND TRACKS		
1311 - WHEEL ASSEMBLY .....		17-1
HUB, DRUM, AND WHEEL .....	17	17-1

## TABLE OF CONTENTS (Con't)

	Illus/ Fig	Page
GROUP 13 WHEELS AND TRACKS (Con't)		
1313 - TIRES, TUBES, TIRE CHAINS .....		18-1
TIRE AND TUBE .....	18	18-1
GROUP 14 STEERING		
1401 - MECHANICAL STEERING GEAR ASSEMBLY .....		19-1
STEERING ARM AND TIE-RODS .....	19	19-1
GROUP 15 FRAME, TOWING ATTACHMENTS, DRAWBARS, AND ARTICULATION SYSTEMS		
1501 - FRAME ASSEMBLY .....		20-1
FRAME COMPONENTS .....	20	20-1
MISCELLANEOUS BRACKETS .....	21	21-1
1503 - PINTLES AND TOWING ATTACHMENTS .....		22-1
PINTLE ASSEMBLY AND REAR DRAWBAR .....	22	22-1
1507 - LANDING GEAR, LEVELING JACKS .....		23-1
CASTER WHEEL ASSEMBLY .....	23	23-1
GROUP 16 SPRINGS AND SHOCK ABSORBERS		
1604 - SHOCK ABSORBER EQUIPMENT .....		24-1
SHOCK ABSORBER, AIR BAG, AND MOUNTING HARDWARE .....	24	24-1
GROUP 18 BODY, CAB, HOOD, AND HULL		
1808 - STOWAGE RACKS, BOXES, STRAPS, CARRYING CASES, CABLE REELS, HOSE REELS, ETC. ....		25-1
TOOLBOX .....	25	25-1
GROUP 22 BODY, CHASSIS, AND HULL ACCESSORY ITEMS		
2202 - ACCESSORY ITEMS .....		26-1
REFLECTORS .....	26	26-1
2210 - DATA PLATES AND INSTRUCTION HOLDERS .....		27-1
DATA PLATES .....	27	27-1
GROUP 24 HYDRAULIC AND FLUID SYSTEMS		
2401 - PUMP AND MOTOR .....		28-1
HYDRAULIC PUMP AND ADAPTER .....	28	28-1
2402 - MANIFOLD AND/OR CONTROL VALVES .....		29-1
CONTROL VALVE .....	29	29-1
2406 - STRAINERS, FILTERS, LINES, AND FITTINGS, ETC. ....		30-1
HYDRAULIC LINES AND FITTINGS, FRONT (SHT 1 OF 2) .....	30	30-1
HYDRAULIC LINES AND FITTINGS, REAR (SHT 2 OF 2) .....		30-1
2407 - HYDRAULIC CYLINDERS .....		31-1
LIFT CYLINDER .....	31	31-1
POSITIONING CYLINDER .....	32	32-1
HYDRAULIC CYLINDER MOUNTING .....	33	33-1

## TABLE OF CONTENTS (Con't)

	Illus/ Fig	Page
GROUP 24 HYDRAULIC AND FLUID SYSTEMS (Con't)		
2408 - LIQUID TANKS OR RESERVOIRS .....		34-1
HYDRAULIC RESERVOIR .....	34	34-1
GROUP 29 AUXILIARY GENERATOR AND ENGINE, AND CONTROLS		
2910 - ENGINE ASSEMBLY .....		35-1
ENGINE ASSEMBLY .....	35	35-1
2913 - FLYWHEEL ASSEMBLY .....		36-1
FLYWHEEL AND RING GEAR .....	36	36-1
2915 - VALVES, CAMSHAFTS, AND TIMING SYSTEM .....		37-1
ROCKER ARM COVER .....	37	37-1
2916 - ENGINE LUBRICATION SYSTEM .....		38-1
OIL FILTER, LINES, AND PLUGS .....	38	38-1
2932 - ENGINE FUEL PUMP .....		39-1
FUEL INJECTION PUMP, NOZZLE, AND LINES .....	39	39-1
2933 - ENGINE AIR CLEANER .....		40-1
AIR CLEANER ASSEMBLY .....	40	40-1
2935 - ENGINE FUEL TANK .....		41-1
FUEL TANK ASSEMBLY .....	41	41-1
2936 - ENGINE SPEED GOVERNOR AND CONTROLS .....		42-1
ENGINE SIDE COVER .....	42	42-1
2941 - ENGINE MUFFLER, EXHAUST, AND TAIL PIPES .....		43-1
MUFFLER AND COVER ASSEMBLY .....	43	43-1
2952 - ENGINE COWLING DEFLECTORS, AIR DUCTS, AND SHROUDS .....		44-1
SPIRAL CASE ASSEMBLY .....	44	44-1
2961 - GENERATOR .....		45-1
STATOR ASSEMBLY .....	45	45-1
2962 - REGULATOR .....		46-1
REGULATOR AND MOUNT .....	46	46-1
2963 - STARTER, SOLENOIDS, CIRCUIT BREAKERS, WIRING, AND SWITCHES .....		47-1
STARTER, SWITCH, AND HARNESS .....	47	47-1
2965 - IGNITION COIL .....		48-1
GLOW PLUG AND CORD .....	48	48-1
GROUP 33 SPECIAL PURPOSE KITS		
3307 - SPECIAL PURPOSE KITS .....		49-1
REDUNDANT POWER KIT .....	49	49-1
SIDE LIFT KIT COMPONENT PARTS .....	50	50-1
SIDE LIFT KIT STORAGE BOX .....	51	51-1
SIDE LIFT KIT HYDRAULIC VALVE PLUG .....	52	52-1
SIDE LIFT KIT POSITIONING CYLINDER .....	53	53-1
SIDE LIFT KIT LIFT CYLINDER .....	54	54-1
COLD START KIT .....	54A	54A-1
GROUP 94 REPAIR KITS		
9401 - REPAIR KITS .....		KITS-1
KITS .....	KITS	KITS-1

## TABLE OF CONTENTS (Con't)

	Illus/ Fig	Page
GROUP 95 GENERAL USE STANDARDIZED PARTS		
9501 - BULK MATERIEL .....		BULK-1
BULK .....	BULK	BULK-1
Section III. Special Tools		
GROUP 26 TOOLS AND TEST EQUIPMENT		
2604 - SPECIAL TOOLS .....		55-1
SPECIAL TOOLS .....	55	55-1
Section IV. Cross-reference Indexes		
NATIONAL STOCK NUMBER INDEX.....		I-1
PART NUMBER INDEX.....		I-14
APPENDIX D COMPONENTS OF END ITEM AND BASIC ISSUE ITEMS LISTS.....		D-1
APPENDIX E ADDITIONAL AUTHORIZATION LIST.....		E-1
APPENDIX F EXPENDABLE AND DURABLE ITEMS LIST.....		F-1
APPENDIX G TOOL IDENTIFICATION LIST .....		G-1
APPENDIX H TORQUE LIMITS .....		H-1
INDEX.....		Index 1

## HOW TO USE THIS MANUAL

This manual is designed to help operate and maintain the M1022A1 Dolly Set. It describes the Operator/Crew, Unit, Direct Support, and General Support Maintenance prescribed by the Maintenance Allocation Chart (MAC) (Appendix B) and the Source, Maintenance, and Recoverability (SMR) Codes (Appendix C).

### FEATURES OF THIS MANUAL:

- A table of contents is provided at the beginning of this manual. An index of all paragraphs contained within a section is found at the beginning of each section.
- Health hazard icons are identified with applicable WARNINGS to assist in easy recognition of a potential hazard. The following list identifies icons used within this manual and an explanation of the associated hazard.



**Material emits radioactive energy and can injure human tissue or organs.**



**Material is poisonous or is a danger to your life.**



**Material may explode if subjected to high temperatures, sources of ignition, or high pressure.**



**Material can ignite and burn you.**



**Material emits vapors which present a danger to your life or health.**



**Material will cause burns or irritation of human skin or tissue.**



**Material will cause injury to your eyes.**

## HOW TO USE THIS MANUAL (Con't)

### FEATURES OF THIS MANUAL (Con't):

- WARNINGS, CAUTIONS, and NOTES, subject headings, and other important information are highlighted in **BOLD** print as a visual aid.

**WARNING**

A **WARNING** indicates a hazard which can result in death or serious injury.

**CAUTION**

A **CAUTION** is a reminder of safety practices or directs attention to usage practices that will prevent damage to equipment.

**NOTE**

A **NOTE** is a statement containing information that will make the procedure easier to perform.

- Statements and words of particular importance are printed in capital letters to create emphasis.
- Instructions are located together with illustrations that show the specific task on which the technician is working.
- Equipment locator illustrations are provided as required throughout the operator and maintenance procedures. These illustrations are for use in locating components and assemblies of the dolly set. It should be noted that the locator illustrations do not always reflect the equipment conditions listed in the "Initial Setup" at the beginning of each task.
- Dashed leader lines used in illustrations indicate that called out items are not visible (i.e., they are located *within* the structure). Dashed leader lines in the Lubrication Chart indicate that lubrication is required on BOTH sides of the equipment.
- This equipment contains metric components and requires metric tools; therefore, technical instructions include metric in addition to standard units. A metric conversion chart is provided on the inside back cover.
- A Repair Parts and Special Tools Lists (RPSTL) is provided at Appendix C.
- A standard torque chart and an engine torque chart are provided at Appendix H.
- An alphabetical index is provided at the end of the manual to assist in locating information not readily found in the table of contents.

## **HOW TO USE THIS MANUAL (Con't)**

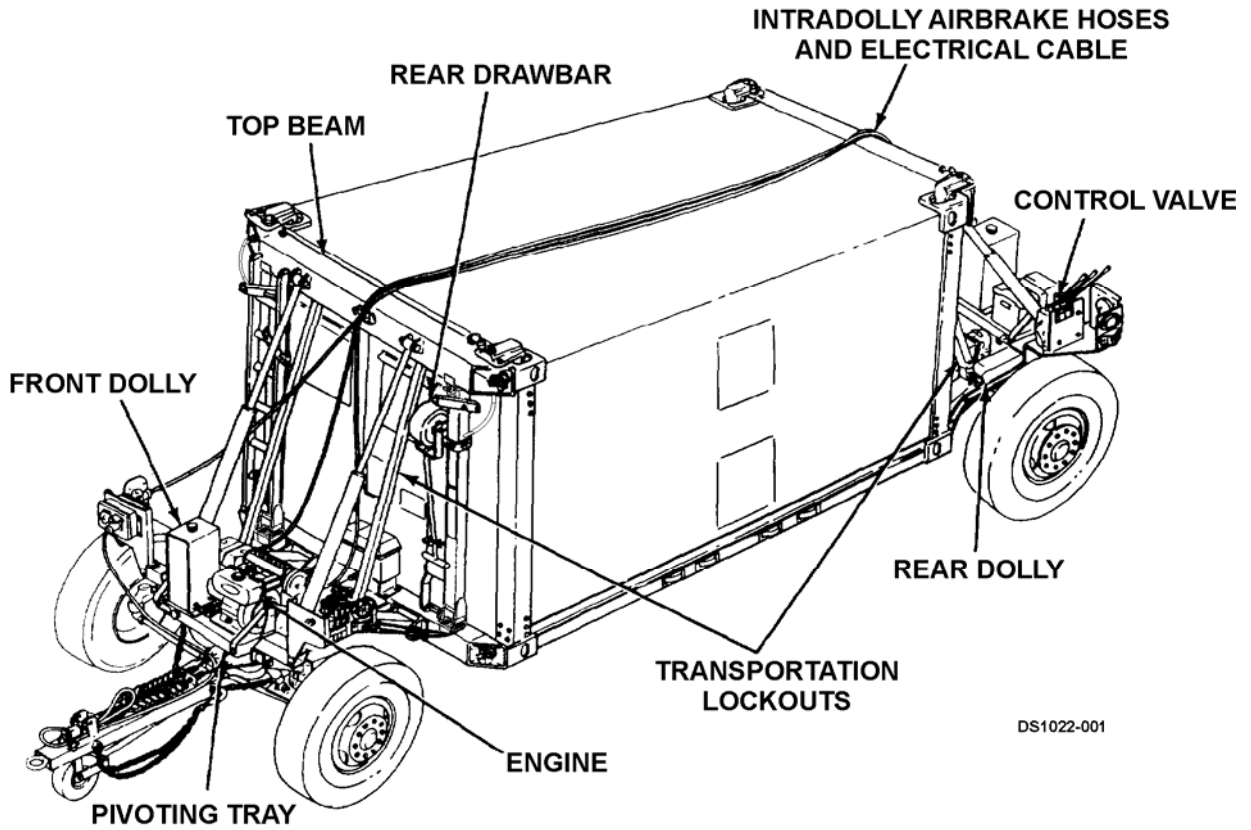
### **FOLLOW THESE GUIDELINES WHEN YOU USE THIS MANUAL:**

- Read through this manual and become familiar with its contents before attempting to operate or maintain the dolly set.
- Read the warning summary provided at the beginning of this manual before performing any operator or maintenance tasks.
- In the actual operation and maintenance tasks, follow all WARNINGS, CAUTIONS, and NOTES. These are given immediately preceding the procedural steps to which they apply. If these instructions are not followed or care is not taken, injury to personnel or equipment damage may result.
- Within a chapter, section, or paragraph, headings are used to help group the material and assist you in quickly finding tasks. Read all preliminary information found at the beginning of each task. After completing a task, ALWAYS perform the follow-on maintenance at the end of the task.

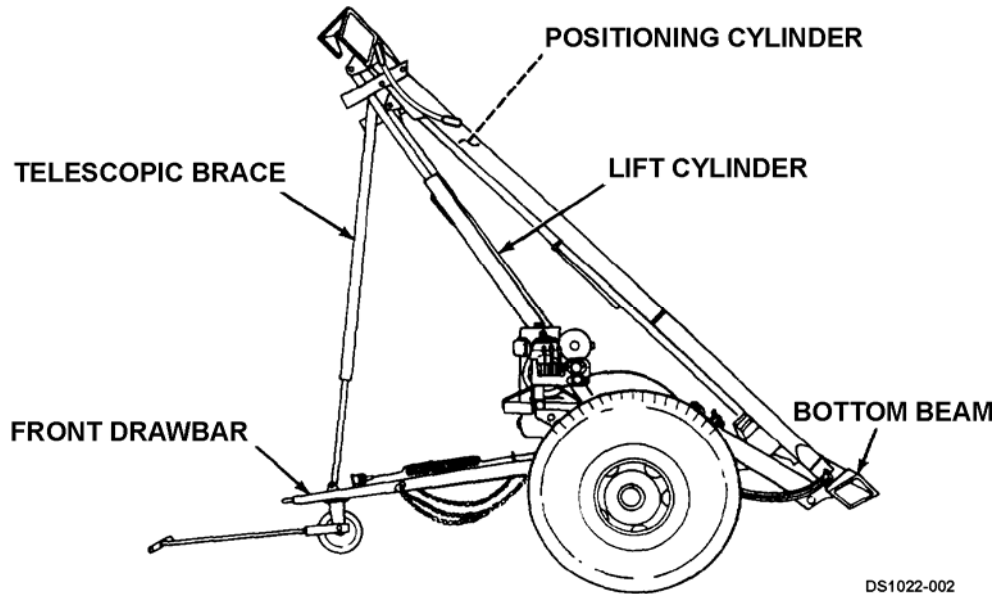








TRANSPORT MODE



MANEUVERING POSITION

# CHAPTER 1 INTRODUCTION

## Section I. GENERAL INFORMATION

Paragraph NUMBER	Paragraph Title	Page Number
1-1.	Scope.. .. .	1-1
1-2.	Maintenance Forms, Records, and Reports. . . . .	1-1
1-3.	Destruction of Army Materiel to Prevent Enemy Use . . . . .	1-1
1-4.	Preparation for Storage or Shipment . . . . .	1-1
1-5.	Official Nomenclature, Names, and Designations . . . . .	1-2
1-6.	Reporting Equipment Improvement Recommendations (EIRs) . . . . .	1-2
1-7.	Warranty Information . . . . .	1-2
1-8.	Safety, Care, and Handling . . . . .	1-2
1-9.	Corrosion Prevention and Control (CPC) . . . . .	1-3
Table 1-1.	Nomenclature Cross-reference List . . . . .	1-2

### **1-1. SCOPE.**

a. Type of Manual. Operator's, Unit, Direct Support, and General Support Maintenance Manual (Including Repair Plans and Special Tools Lists).

b. Equipment Name and Model Number. Dolly Set: Lift, Transportable Shelter, 7½ Ton, M1022A1.

c. Purpose of Equipment.

(1) The dolly set is designed to provide full ground mobility for International Standard Organization (ISO) containers and shelters up to 15,000 lb (6810 kg) gross maximum weight.

(2) The M1022A1 Dolly Set is designed to lift at ends of containers. With the installation of a side lift kit, the M1022A1 provides both side lift and end lift capabilities.

### **1-2. MAINTENANCE FORMS, RECORDS, AND REPORTS.**

Department of the Army forms and procedures used for equipment maintenance will be those prescribed by DA Pam 750-8, *The Army Maintenance Management System (TAMMS)*.

### **1-3. DESTRUCTION OF ARMY MATERIEL TO PREVENT ENEMY USE.**

For destruction of Army materiel to prevent enemy use, refer to TM 750-244-6.

### **1-4. PREPARATION FOR STORAGE OR SHIPMENT.**

For information on preparing the dolly set for storage or shipment, refer to Chapter 4, Section XVIII.

---

**1-5. OFFICIAL NOMENCLATURE, NAMES, AND DESIGNATIONS.**

---

Official nomenclature is generally used throughout the manual; however, some nomenclature has been abbreviated or shortened to make the procedures easier to follow. Table 1-1 provides a cross-reference between the official nomenclature and the abbreviated nomenclature.

**Table 1-1. Nomenclature Cross-reference List.**

Official Nomenclature	Abbreviated Nomenclature
Auxiliary Engine .....	Engine
Jack Stand .....	Trestle
Lockout Brace .....	Transportation Lockout
Oil Level Gage .....	Dipstick
O-ring .....	Preformed Packing
Preformed Packing .....	O-ring
Push-pull Valve .....	Airbrake Valve
Steering Arm Assembly .....	Steering Link
Twist Lock Assembly .....	Twist Lock

---

**1-6. REPORTING EQUIPMENT IMPROVEMENT RECOMMENDATIONS (EIRs).**

---

If your dolly set needs improvement, let us know. Send us an EIR. You, the user, are the only one who can tell us what you don't like about your equipment. Let us know why you don't like the design or performance. Put it on an SF Form 368 (Product Quality Deficiency Report). Mail it to us at: Commander, U.S. Army Tank-Automotive Command, ATTN: AMSTA-QT, Warren, MI 48397-5000. We'll send you a reply.

---

**1-7. WARRANTY INFORMATION.**

---

The M1022A1 Dolly Set is under warranty by the Engineered Systems Company in accordance with TB 9-2330-390-12.

---

**1-8. SAFETY, CARE, AND HANDLING.**

---

a. **First Aid.** Refer to FM 4-25.11, First Aid for Soldiers, for first aid treatments of injured personnel. **IMMEDIATELY** seek medical attention for any injury. The following first aid procedures should be used to prevent further injury until medical attention is available.

(1) **Exhaust Gases or Toxic Fumes.** Expose person to fresh air and keep warm. DO NOT permit person to move. If necessary, administer Cardiovascular Pulmonary Resuscitation (CPR) and immediately seek medical attention.

(2) Chemical Burns.

(a) Eyes. Flush eyes with cold water for no less than 15 minutes. Immediately seek medical attention.

(b) Skin. Flush area with large amounts of cold water until all acid is removed. Seek medical attention as required.

---

**1-8. SAFETY, CARE, AND HANDLING (Con't).**

---

- (c) Internal. Drink large amounts of water or milk followed by milk of magnesia, beaten egg, or vegetable oil. Immediately seek medical attention.
  - (d) Clothing or Equipment. Immediately wash area with large amounts of cold water. Neutralize acid with baking soda or household ammonia.
- (3) **Foreign Object in Eye**. DO NOT attempt to remove foreign object from eye as object may cause cuts and abrasions. Close eye, cover with gauze and tape, and immediately seek medical attention.

**b. Personnel and Dolly Set Precautions.**

- (1) Read and become familiar with all WARNINGS in the warning summary at the front of this manual.
- (2) WARNING decals on the dolly set provide safety instructions and identify specific hazards which, if not followed, may result in serious injury or death to personnel.
- (3) Throughout this manual, WARNINGS and CAUTIONS are given immediately preceding the procedural steps to which they apply. Read these WARNINGS and CAUTIONS and follow them exactly.
- (4) When operating or maintaining the dolly set, keep hands, feet, and clothing clear of all moving parts. Remove watches, rings, and other jewelry which could catch on moving parts and cause injury.
- (5) When performing maintenance, protect yourself against injury. Wear protective gear such as safety goggles or lenses, safety shoes, rubber apron, gloves, etc.
- (6) Notify others in the area if you are handling flammable materials. Know location of fire extinguishers and emergency procedures in case of accident or fire.
- (7) Never operate the engine in a closed area unless there is good ventilation. Be alert for signs of carbon monoxide poisoning. If symptoms are noticed, immediately evacuate and ventilate the area.
- (8) Never leave dolly set unattended while engine is running.
- (9) Before performing maintenance, ensure that the dolly set is secured against movement. Park dolly set on level ground with rear dolly parking brakes applied. If parking brakes are not functioning, chock wheels.
- (10) When lifting heavy parts, have someone help you. Ensure that lifting or jacking equipment is working properly, is of sufficient capacity for the assigned task, and is secure against slipping.

---

**1-9. CORROSION PREVENTION AND CONTROL (CPC).**

---

- a. Corrosion Prevention and Control (CPC) of Army materiel is a continuing concern. It is important that any corrosion problems with the dolly set be reported so that the problem can be corrected and improvements can be made to prevent the problem in future items.
- b. While corrosion is typically associated with rusting of metals, it can also include deterioration of other materials, such as rubber and plastic. Unusual cracking, softening, swelling, or breaking of these materials may be a corrosion problem.
- c. If a corrosion problem is identified, report it using SF Form 368 (Product Quality Deficiency Report). Use of key words such as "corrosion", "rust", "deterioration", or "cracking" will ensure that the information is identified as a CPC problem. Submit the form to the address specified in DA Pam 750-8.

## Section II. EQUIPMENT DESCRIPTION AND DATA

Paragraph Number	Paragraph Title	Page Number
1-10.	Equipment Characteristics, Capabilities, and Features .....	1-4
1-11.	Location and Description of Major Components .....	1-6
1-12.	Location and Contents of Data Plates .....	1-11
1-13.	Location and Contents of Decals .....	1-21
1-14.	Location and Contents of Stencils .....	1-23
1-15.	Equipment Data .....	1-24
Table 1-2.	General Characteristics and Specifications .....	1-24

---

### 1-10. EQUIPMENT CHARACTERISTICS, CAPABILITIES, AND FEATURES.

---

a. The M1022A1 Dolly Set consists of two separate and independent halves: a front dolly and a rear dolly.

(1) The dolly halves attach to an International Standard Organization (ISO) container or shelter to make up the dolly set trailer.

(2) Using dolly set power, the shelter or container is raised to traveling height and leveled. The dolly set trailer can then be coupled to a towing vehicle and transported to a new location.

(3) A 15,009 lb (6810 kg) maximum payload can be lifted and towed by the M1022A1 at 55 mi/h (89 km/h) highway speed.

(4) Authorized towing vehicle is any military tactical wheeled vehicle of 5 ton rating or greater, equipped with a pintle assembly and standard electrical and airbrake connections.

(5) Two dolly sets without shelters can be towed in tandem. Maximum towing speed when tandem towing is 25 mi/h (40 km/h) for off public road use only.

(6) The dolly set, with or without shelter, can hardbottom ford up to a depth covering the wheel hubs.

(7) The dolly set can be transported by highway, rail, marine, and air modes.

b. Features of the M1022A1 include:

(1) a 12-volt electrical lighting system with 24-volt blackout lights.

(2) four-wheel full air wedge brakes, emergency breakaway braking, and rear dolly parking brakes.

(3) front and rear drawbars with caster wheels; front drawbar has a fixed lunette.

(4) hydraulic loading/lifting system, powered by a diesel engine, on each dolly half. In the event of system failure on one dolly, the hydraulic system is configured to accommodate an optional redundant power kit, used only for end lift operations.

(5) suspension air bag and standard automotive shock absorber,

---

**1-10. EQUIPMENT CHARACTERISTICS, CAPABILITIES, AND FEATURES (Con't).**

---

**NOTE**

**There is no spare tire mounted on the dolly set. A spare must be obtained from the towing vehicle or the motor pool.**

(1) tire changing flexibility using either towing vehicle jack or dolly set hydraulic system to raise wheel and tire assemblies off the ground.

(2) towing, electrical, and airbrake connections on the rear dolly which allow for tandem towing of a second (empty) dolly set.

(3) standard lift and tie-down points (D-rings) on front and rear axles.

c. The M1022A1 can be equipped with a side lift kit, installed by Direct Support Maintenance. With the side lift kit installed, the dolly set is used as a container-handling device as well as a transport device. Containers can be loaded and unloaded to or from flatbed trucks, trailers, and railcars. They can be cross-loaded between modes of transportation and transported over short distances. Features of the M1022A1 equipped with side lift kit are:

(1) capability to side lift a 20 ft (6.1 m) container with a maximum payload of 15,000 lb (6810 kg) on a smooth and level grade.

(2) maximum ground clearance at container of 58 in. (147.32 cm).

(3) maximum towing speed of 5 mi/h (8 km/h) over short transport distances [100 ft (30.5 m)].

(4) operational cycle performed by four trained personnel in 30 minutes or less.

d. The M1022A1 can be equipped with a cold start kit, installed by Unit Maintenance. This allows engine to start in extreme temperatures of -26°F to -50°F (-32° to -46°C).

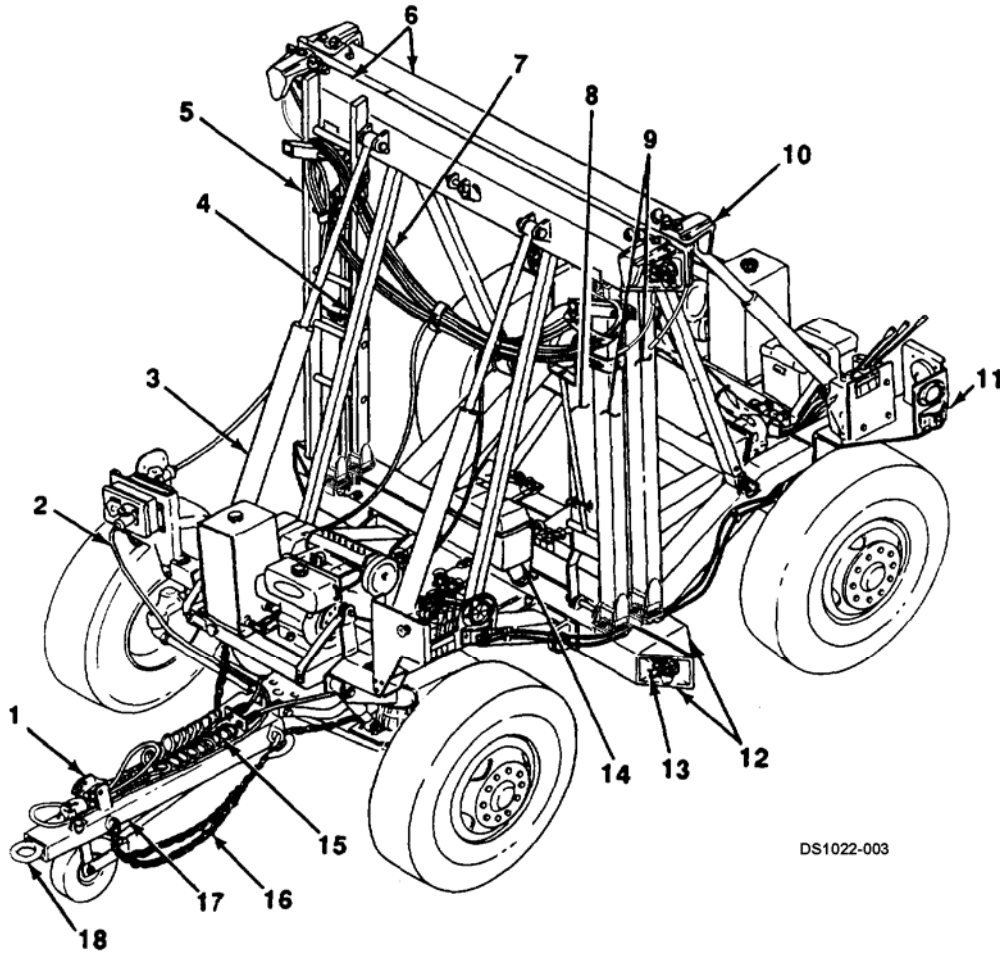


**1-11. LOCATION AND DESCRIPTION OF MAJOR COMPONENTS**

**NOTE**

Unless otherwise indicated, components are located on both front and rear dollies.

**1-11. LOCATION AND DESCRIPTION OF MAJOR COMPONENT**



DS1022-003

Key	Component	Description
1	Dummy Couplings (Front Dolly)	Provide storage for intervehicular gladhands when not in use.
2	Intervehicular Cable (Front Dolly)	Provides electrical connection to operate lights. Two are provided (12v and 24v).

---

**1-11. LOCATION AND DESCRIPTION OF MAJOR COMPONENTS (Cont).**

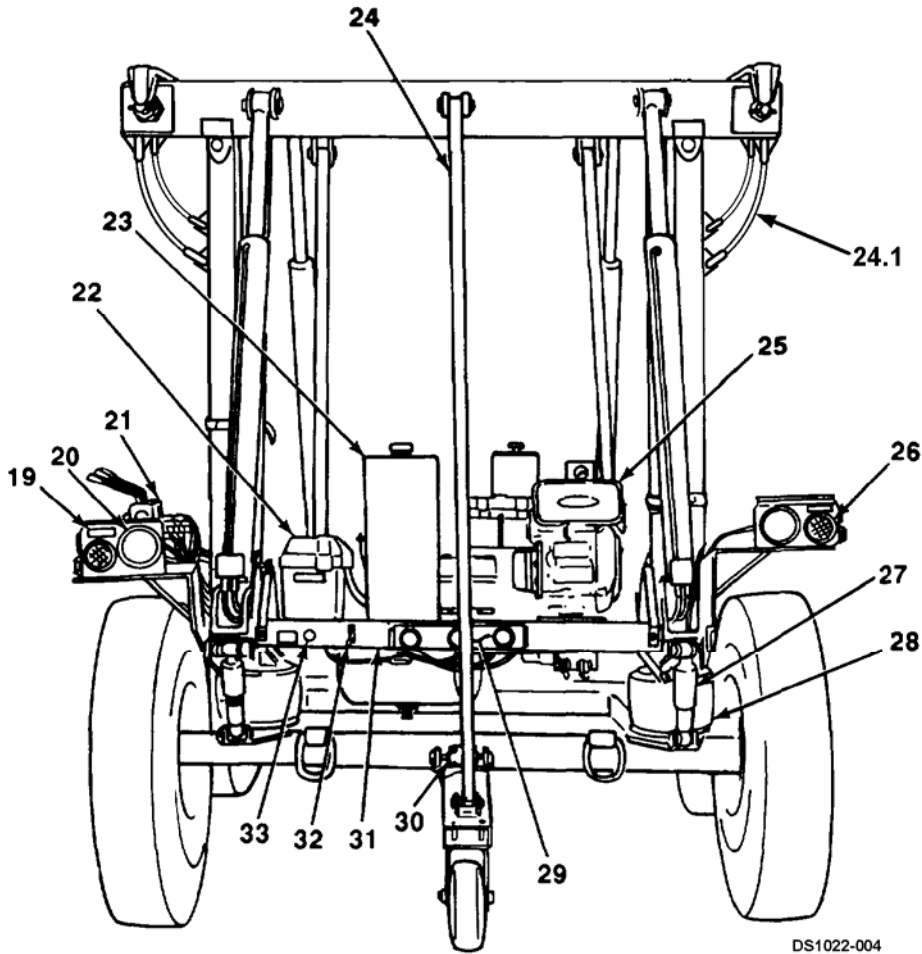

---

Key	Component	Description
3	Lift Cylinders	Raise and lower shelter.
4	Transportation Lockouts	In the event of hydraulic system failure, support dolly set and shelter during transport.
5	Ladder	Used to reach top beams to remove and install twist locks.
6	Top Beams	Provide adjustable attachment point for top of shelter.
7	Intradolly Airbrake Hoses and Electrical Cable (Stowed Position)	Provide intradolly airbrake and electrical connections.
8	Rear Drawbar	Attaches to fixed rear axle. Used for manual positioning of rear dolly.
9	Positioning Cylinders	Position top and bottom beams at the shelter. Housed inside telescoping vertical tubes of top and bottom beams.
10	Top Hooks	Engage with top of shelter.
11	Marker Clearance Lights	Indicate presence of dolly set from the side. Front lights have amber lenses; rear lights have red lenses.
12	Bottom Beams	Provide adjustable attachment point for bottom of shelter.
13	Twist Locks	Secure top and bottom beams to each other or to shelter.
14	Toolbox (Front Dolly)	Provides covered storage for all dolly set Basic Issue Items (BI) and Components of End Item (COEI).
15	Intervehicular Airbrake Hoses (Front Dolly)	Provide service and emergency air connections to operate brakes.
16	Safety Chains (Front Dolly)	Prevent dolly set from fully breaking away from towing vehicle.
17	Front Drawbar (Front Dolly)	Attaches to steerable front axle to aid in steering of front dolly. Has a fixed towing lunette.
18	Lunette	Couples to towing vehicle pintle assembly.

1-11. LOCATION AND DESCRIPTION OF MAJOR COMPONENTS (Cont).

NOTE

Unless otherwise indicated, components are located on both front and rear dollies.



DS1022-004

Key	Component	Description
19	Blackout Stoplight-Taillights (Rear Dolly)	Provide blackout lights on rear dolly.
20	Taillights (Rear Dolly)	Provide tail, stop, and turn signal lights on rear dolly.

---

**1-11. LOCATION AND DESCRIPTION OF MAJOR COMPONENTS (Cont).**

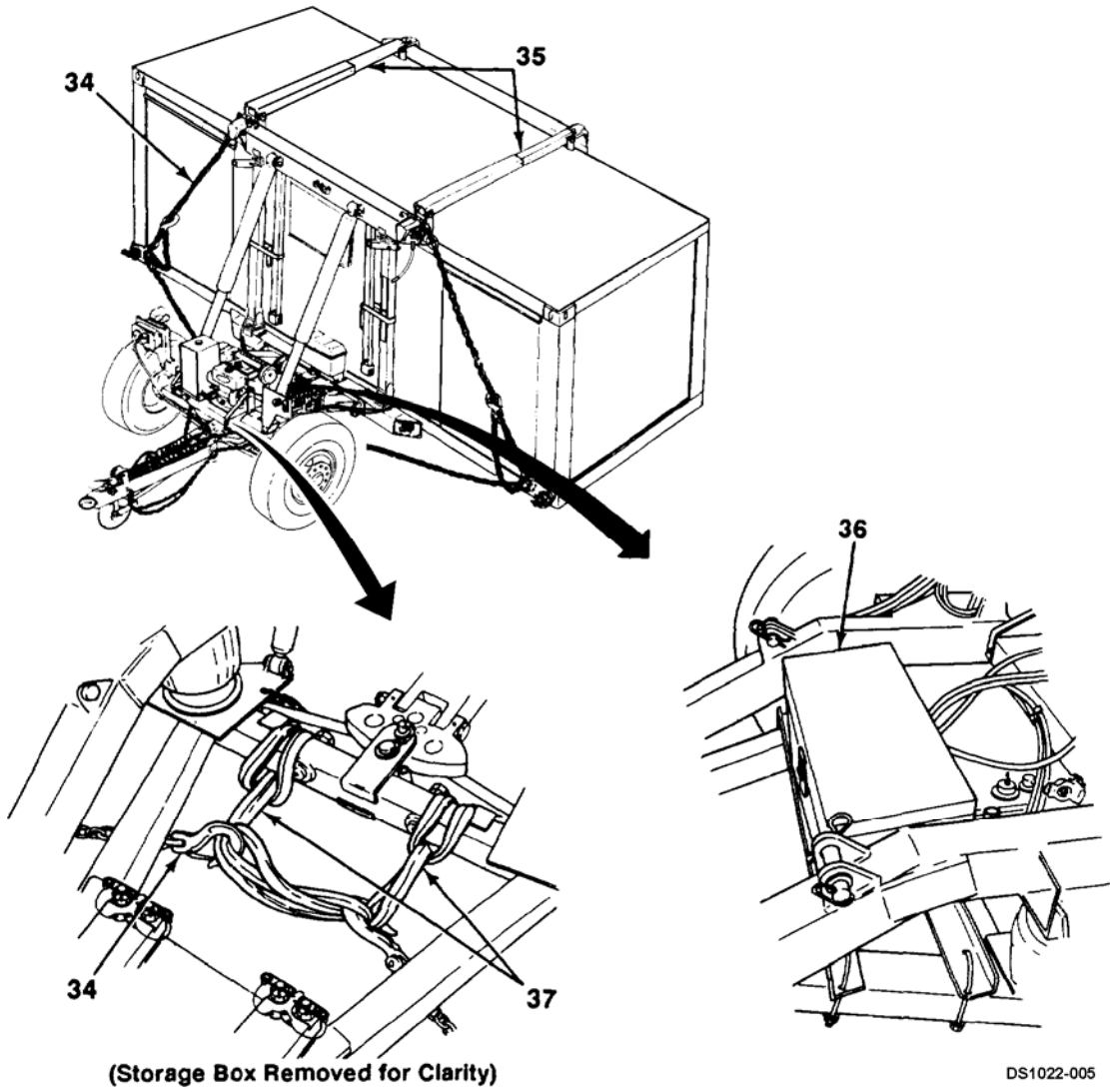

---

Key	Component	Description
21	Hydraulic Control Valve	Has three levers which control the lift and positioning cylinders.
22	Battery Case	Houses 12-volt battery.
23	Hydraulic Reservoir	Contains hydraulic fluid.
24	Telescopic Brace	Supports frame and prevents dolly half from overturning when in maneuvering position.
24.1	Stability Cable	Stabilizes top beam and vertical tube/positioning cylinder connection.
25	Engine	Powers dolly set hydraulic system.
26	Reflectors	Mark outline of dolly set.
27	Shock Absorbers	Dampen road shock.
28	Air Bags	Inflate to provide cushioning and proper riding height for shelter.
29	Identification Light (Rear Dolly)	Provides running lights at midpoint of rear dolly.
30	Pintle Assembly (Rear Dolly)	Used for tandem towing.
31	Pivoting Tray	Provides mounting surface for engine and other components.
32	Parking Brake Lever (Rear Dolly)	Applies and releases parking brakes on rear dolly.
33	Airbrake Control Knob	Applies or releases front and rear dolly service brakes when dolly set is uncoupled from towing vehicle.

1-11. LOCATION AND DESCRIPTION OF MAJOR COMPONENTS (Con't).

NOTE

Unless otherwise indicated, components are located on both front and rear dollies.



SIDE LIFT KIT CONFIGURATION

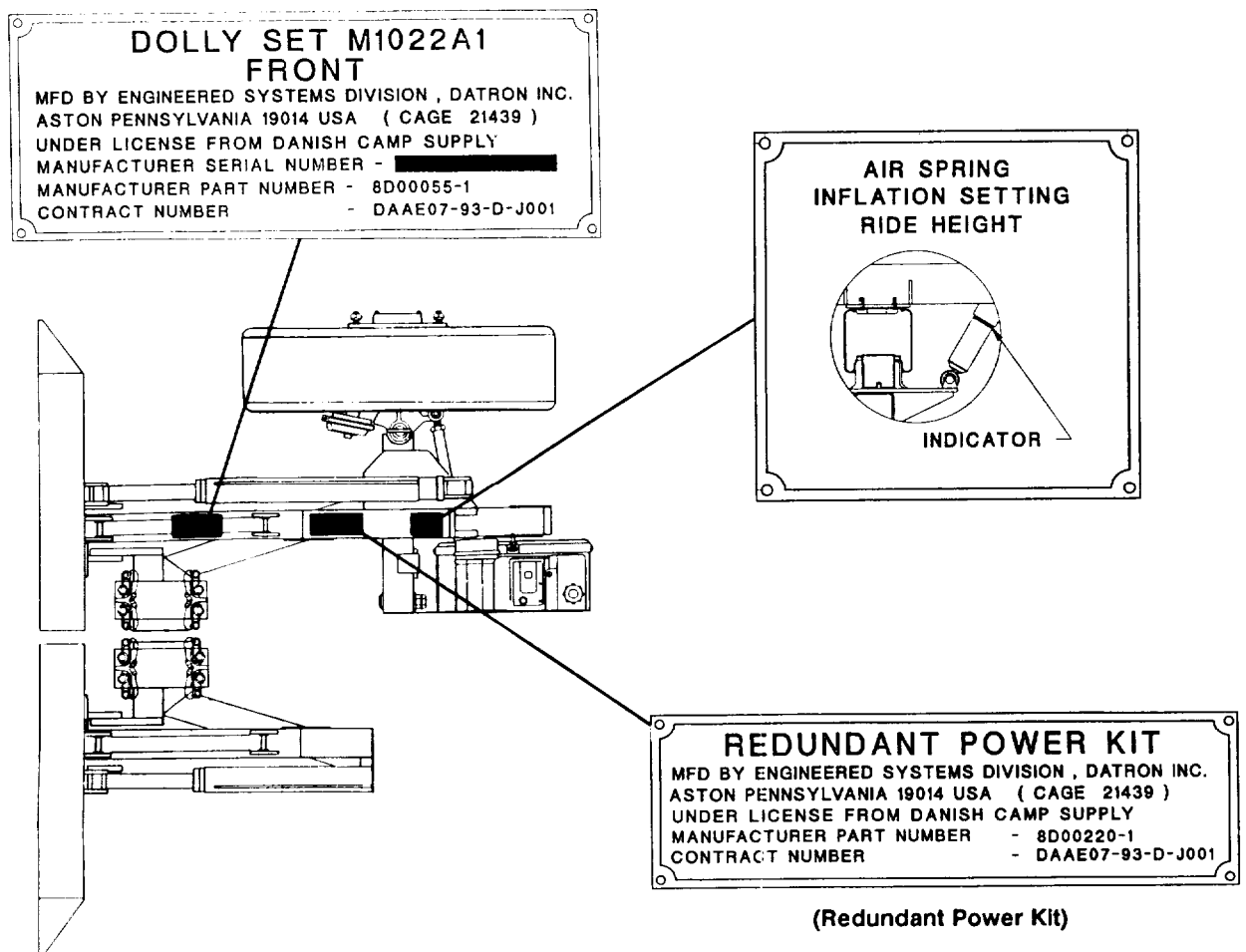
Key	Component	Description
34	Chain Assemblies	Provide attachment link between shelter and dolly halves during side lift operation
35	Crossbrace Assemblies	Link front and rear dolly top beams over shelter during side lift operation.

**1-11. LOCATION AND DESCRIPTION OF MAJOR COMPONENTS (Con't).**

Key	Component	Description
36	Storage Box (Front Dolly)	Contains components of side lift kit.
37	Slings	Connect axle chains to axle.

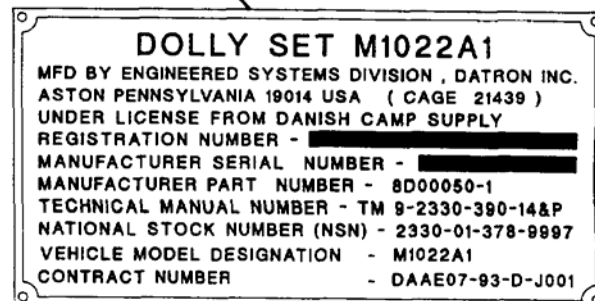
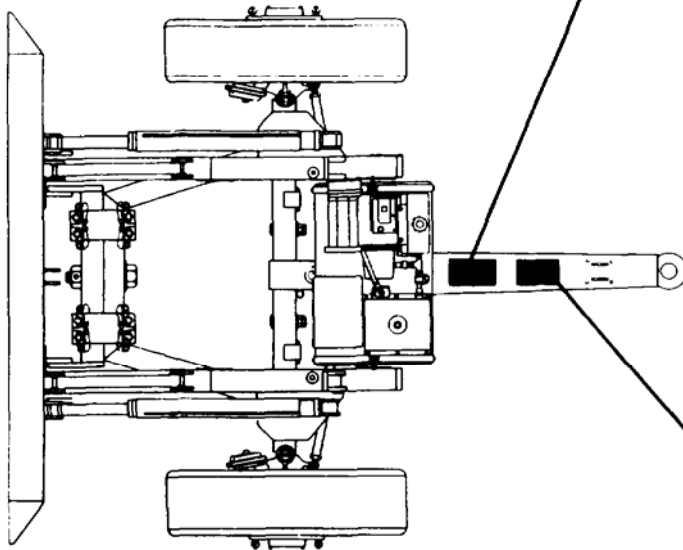
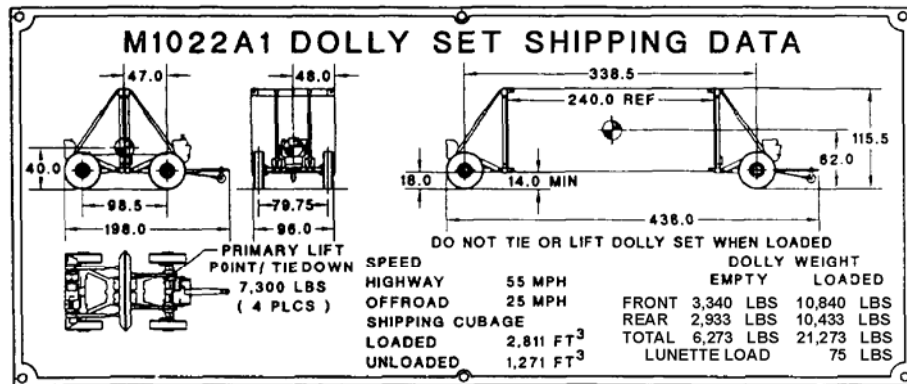
**1-12. LOCATION AND CONTENTS OF DATA PLATES.**

The following illustrations identify the location and contents of all dolly set data plates.



**FRONT DOLLY**

1-12. LOCATION AND CONTENTS OF DATA PLATES (Con't).



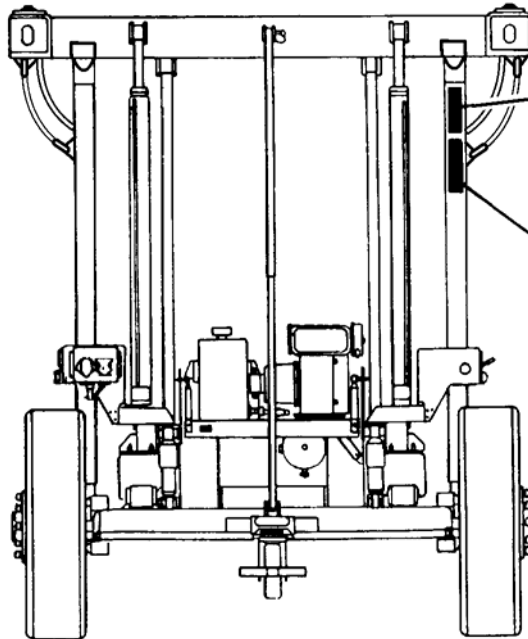
DS1022-134

FRONT DOLLY

1-12. LOCATION AND CONTENTS OF DATA PLATES (Con't).

NOTE

Instruction data plates are on vertical positioning tubes on both ends. One end shown.



- COUPLING INSTRUCTIONS**
- 17 POSITION DOLLIES AT EACH END OF CONTAINER.
  - 18 GUIDE TOP HOOKS INTO CONTAINER.
  - 19 ALIGN BOTTOM OF EACH DOLLY WITH CONTAINER.
  - 20 INSTALL BOTTOM TWIST LOCKS.
  - 21 INSTALL TOP TWIST LOCKS.
  - 22 REMOVE TELESCOPIC BRACES & STOW.
  - 23 REMOVE REAR TOW BAR AND STOW.
  - 24 SELECT PARKING BRAKE - ON.
  - 25 CONNECT INTRA DOLLY BRAKE AND ELECTRICAL LINES.
  - 26 CONNECT INTER VEHICLE BRAKE AND ELECTRICAL LINES.
  - 27 PRESSURIZE AIR SPRING TO MAX PRIME MOVER PRESSURE.
  - 28 RAISE DOLLIES.
  - 29 INSTALL TRANSPORTATION LOCK OUTS.
  - 30 STOP ENGINE.
  - 31 REMOVE STEERING LOCK OUT PIN AND STOW.
  - 32 CONNECT TOW BAR AND SAFETY CHAINS TO PRIME MOVER.
  - 33 SELECT PARKING BRAKE - OFF.
  - 34 ADJUST AIR SPRINGS TO RIDE HEIGHT.
  - 35 CHECK LIGHT OPERATION.

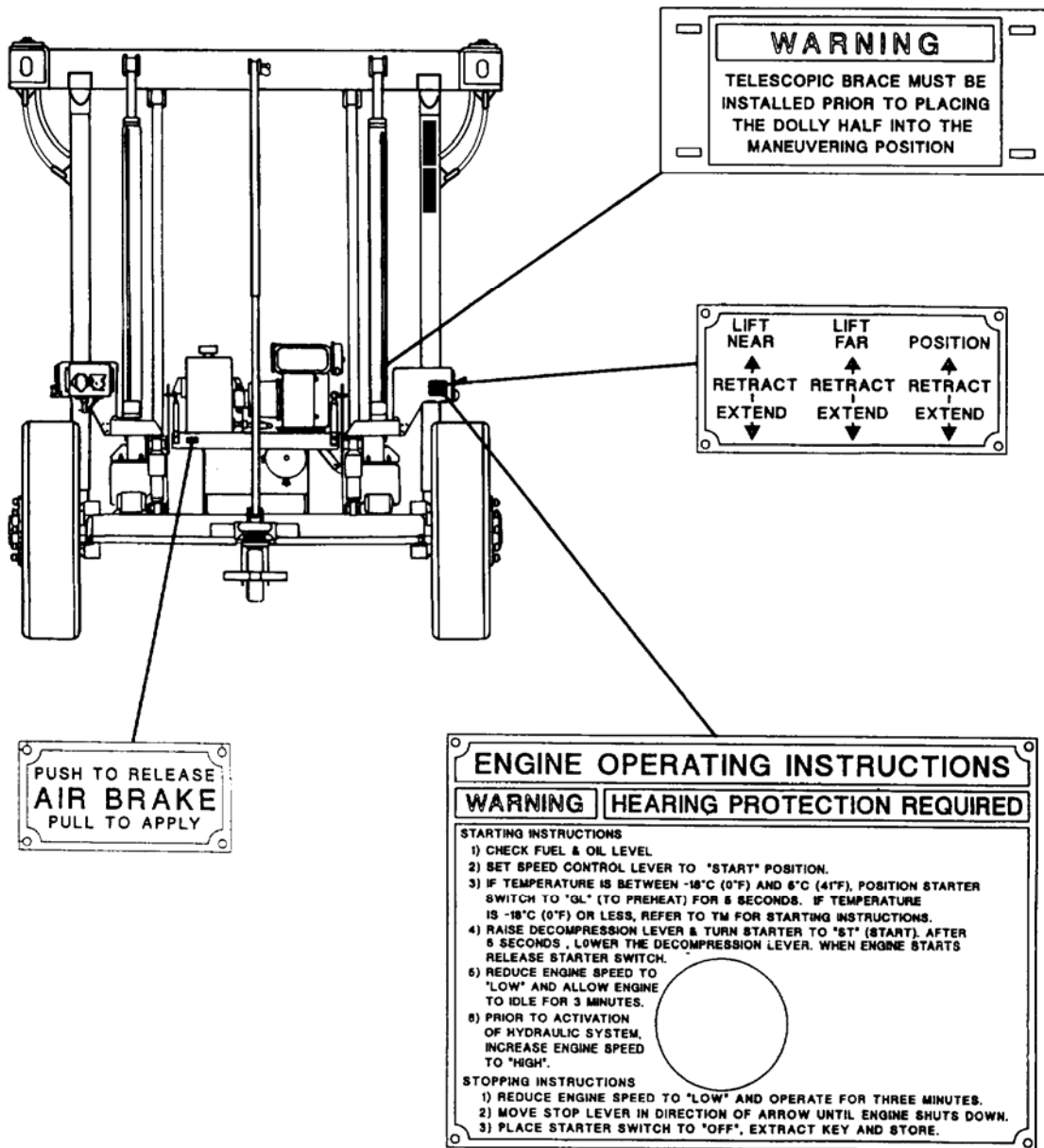
- UNCOUPLING INSTRUCTIONS**
- 'WARNING'**  
TELESCOPIC BRACES MUST BE INSTALLED PRIOR TO ATTEMPTING THIS OPERATION.
- 1 SELECT PARKING BRAKE. - ON.
  - 2 DISCONNECT GLAD HANDS, ELECTRIC CABLE AND CHAINS FROM PRIME MOVER.
  - 3 DISCONNECT DOLLY FROM PRIME MOVER.
  - 4 RELEASE FRONT AIR BRAKES.
  - 5 INSTALL STEERING LOCKOUT PIN.
  - 6 DEFLATE AIR SPRINGS.
  - 7 DISCONNECT AND REMOVE THE INTRA DOLLY BRAKE AND ELECTRICAL LINES.
  - 8 INSTALL REAR TOW BAR.
  - 9 INSTALL TELESCOPIC BRACES.
  - 10 START ENGINE.
  - 11 DISENGAGE TRANSPORTATION LOCKOUTS AND STOW.
  - 12 LOWER DOLLIES TO THE GROUND.
  - 13 RELEASE REAR AIR BRAKE - PARKING BRAKE OFF.
  - 14 REMOVE ALL TWIST LOCKS - TOP FIRST.
  - 15 ROTATE TOP HOOKS TO HANDLING POSITION - IF REQ'D.
  - 16 POSITION DOLLY HALVES INTO MANEUVERING POSITION.

FRONT DOLLY

DS1022-006



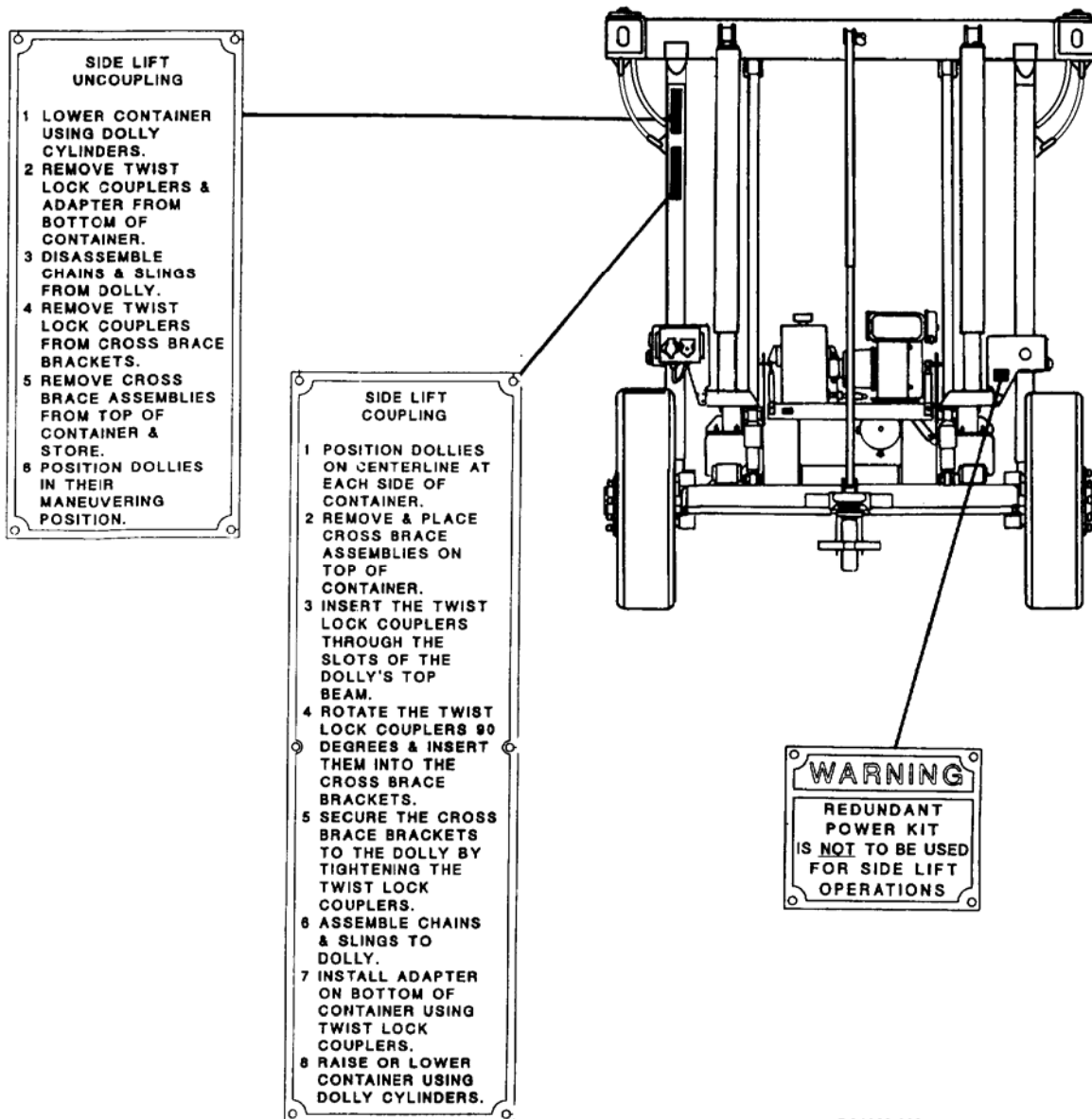
1-12. LOCATION AND CONTENTS OF DATA PLATES (Con't).



DS1022-007

FRONT DOLLY

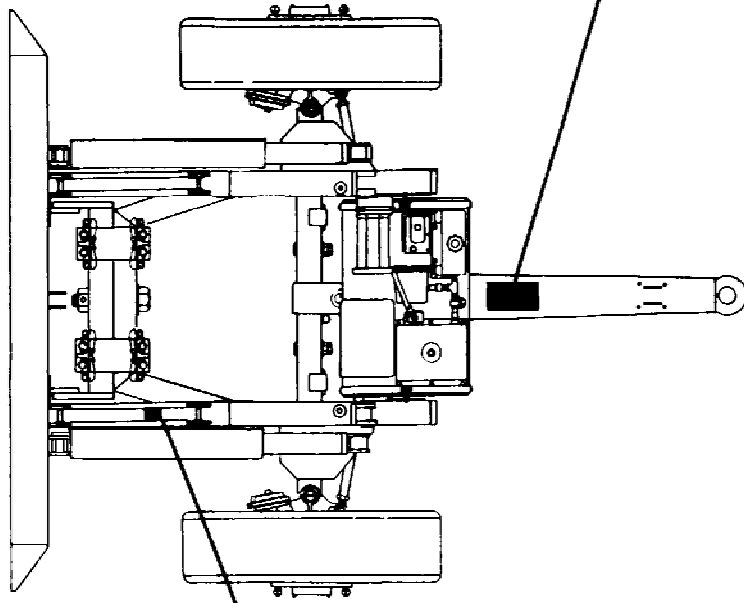
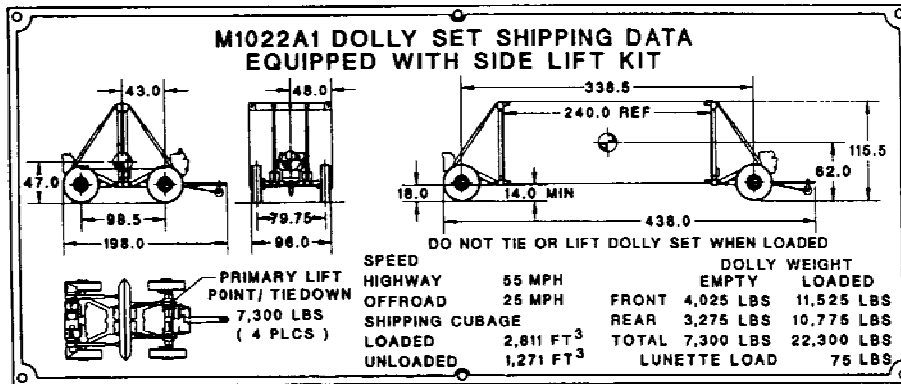
1-12. LOCATION AND CONTENTS OF DATA PLATES (Con't).



DS1022-008

FRONT DOLLY WITH SIDE LIFT KIT

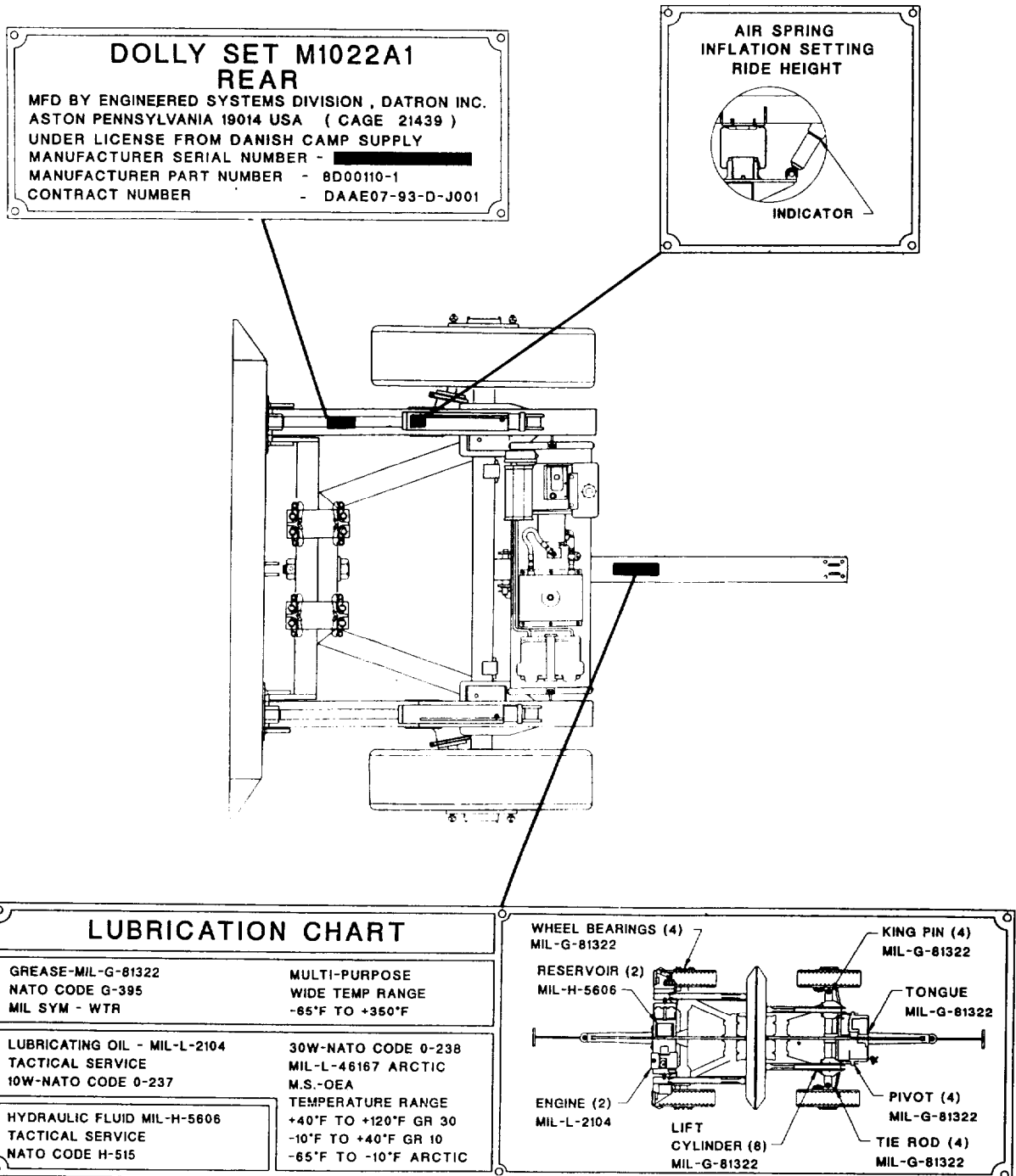
1-12. LOCATION AND CONTENTS OF DATA PLATES (Con't).



**SIDE LIFT KIT**  
MFD BY ENGINEERED SYSTEMS DIVISION, DATRON INC.  
ASTON PENNSYLVANIA 19014 USA ( CAGE 21439 )  
UNDER LICENSE FROM DANISH CAMP SUPPLY  
MANUFACTURER PART NUMBER - 8D00184-1  
CONTRACT NUMBER - DAAE07-93-D-J001

FRONT DOLLY WITH SIDE LIFT KIT

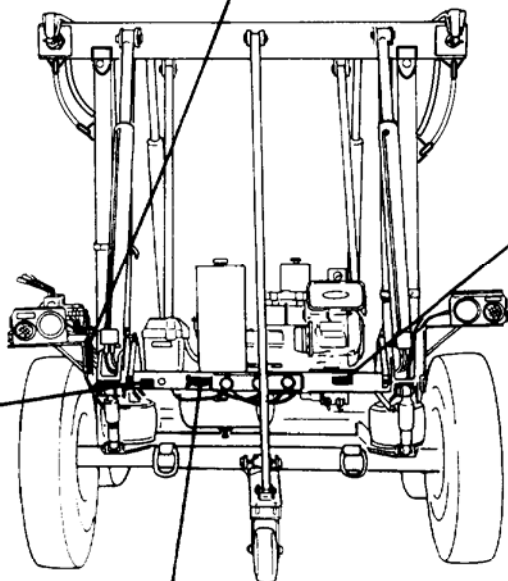
1-12. LOCATION AND CONTENTS OF DATA PLATES (Con't).



REAR DOLLY

1-12. LOCATION AND CONTENTS OF DATA PLATES (Con't).

ENGINE OPERATING INSTRUCTIONS	
<b>WARNING</b>	<b>HEARING PROTECTION REQUIRED</b>
<b>STARTING INSTRUCTIONS</b>	
1) CHECK FUEL & OIL LEVEL	
2) SET SPEED CONTROL LEVER TO 'START' POSITION.	
3) IF TEMPERATURE IS BETWEEN -18°C (0°F) AND 5°C (41°F), POSITION STARTER SWITCH TO 'GL' (TO PREHEAT) FOR 5 SECONDS. IF TEMPERATURE IS -18°C (0°F) OR LESS, REFER TO TM FOR STARTING INSTRUCTIONS.	
4) RAISE DECOMPRESSION LEVER & TURN STARTER TO 'ST'. AFTER 5 SECONDS, LOWER THE DECOMPRESSION LEVER. WHEN ENGINE STARTS, RELEASE STARTER SWITCH.	
5) REDUCE ENGINE SPEED TO 'LOW' AND ALLOW ENGINE TO IDLE FOR THREE MINUTES.	
6) PRIOR TO ACTIVATION OF HYDRAULIC SYSTEM, INCREASE ENGINE SPEED TO 'HIGH'.	
<b>STOPPING INSTRUCTIONS</b>	
1) REDUCE ENGINE SPEED TO 'LOW' AND OPERATE FOR THREE MINUTES.	
2) MOVE STOP LEVER IN DIRECTION OF ARROW UNTIL ENGINE SHUTS DOWN.	
3) PLACE STARTER SWITCH TO 'OFF', EXTRACT KEY AND STORE.	



PUSH TO RELEASE  
**AIR BRAKE**  
PULL TO APPLY

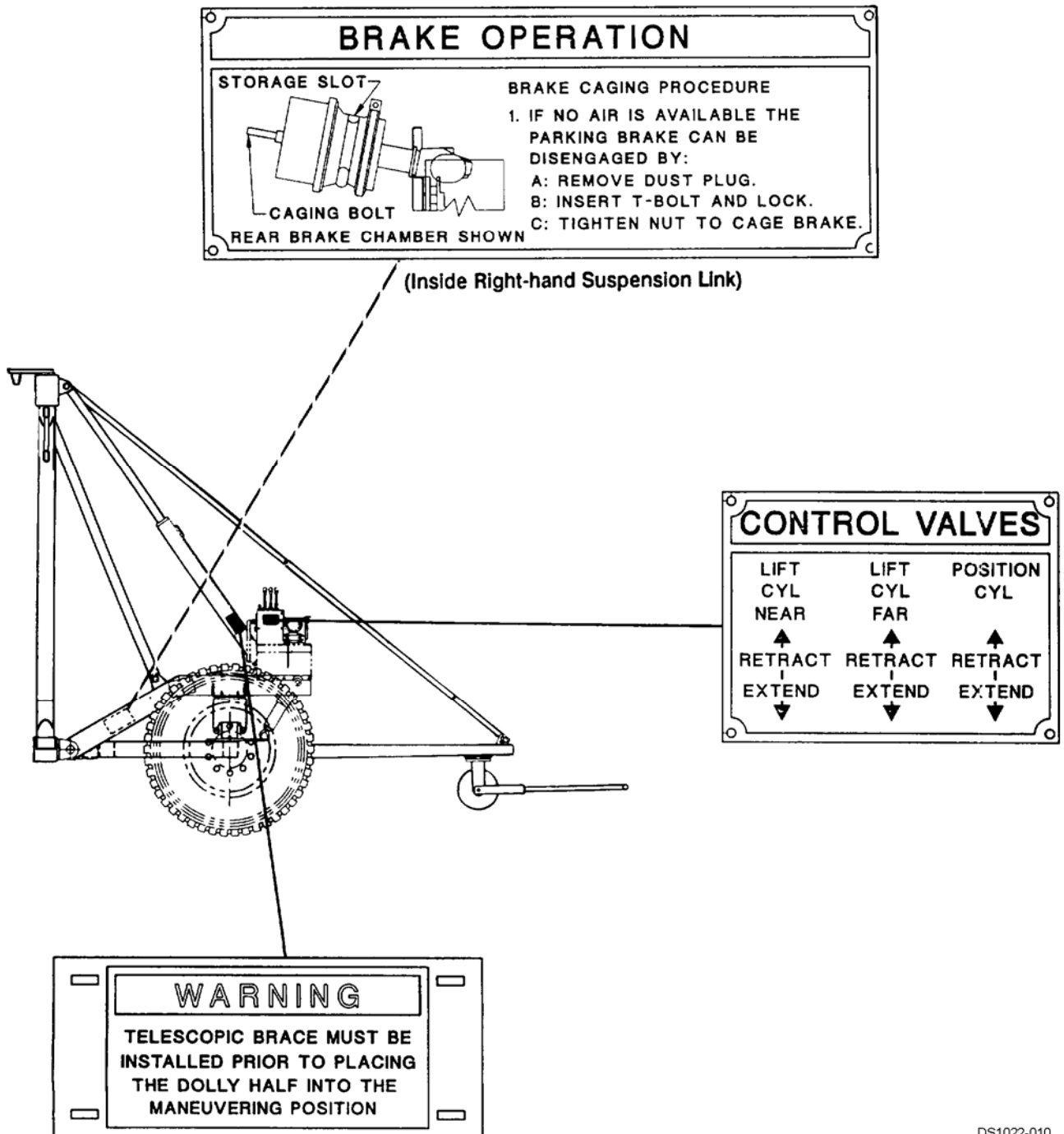
**WARNING**  
DO NOT TOW LOADED  
SHELTERS IN TANDEM

ON  
**PARKING  
BRAKE**  
OFF

DS1022-009

REAR DOLLY

1-12. LOCATION AND CONTENTS OF DATA PLATES (Con't).



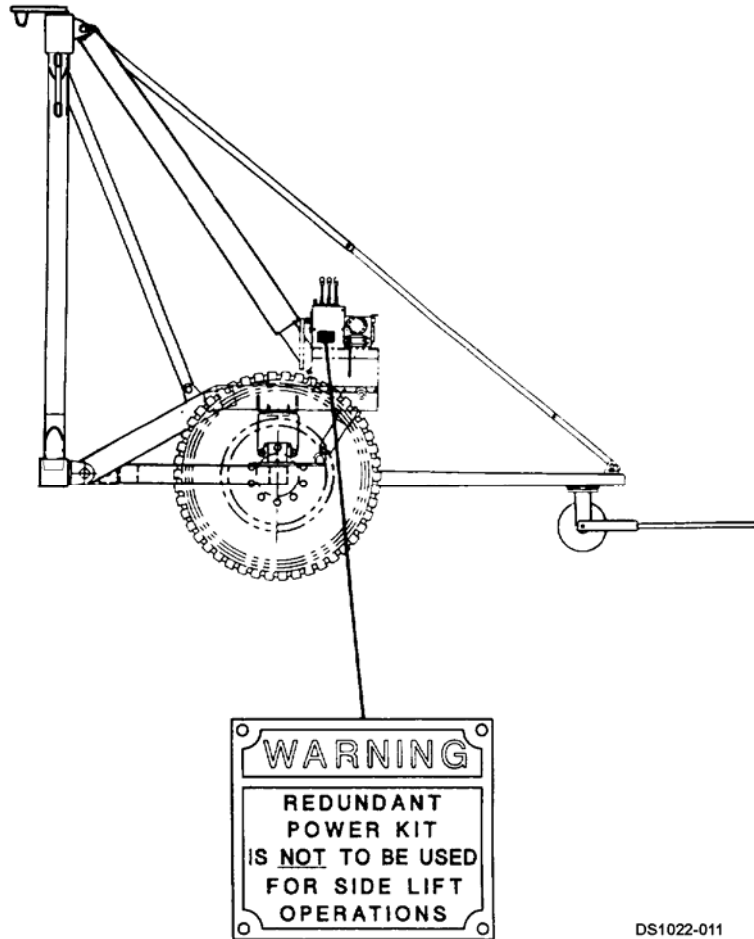
DS1022-010

REAR DOLLY

---

1-12. LOCATION AND CONTENTS OF DATA PLATES (Con't).

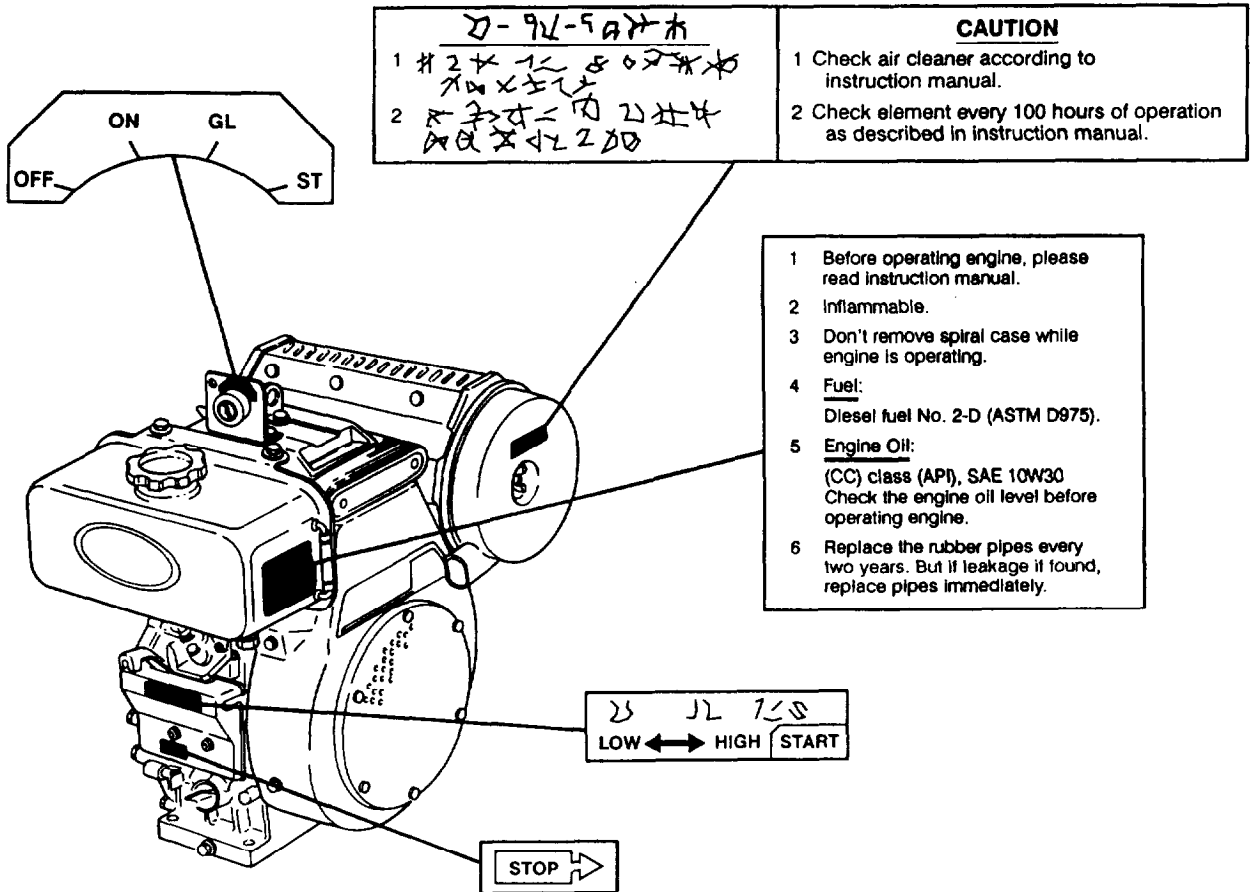
---



REAR DOLLY WITH SIDE LIFT KIT

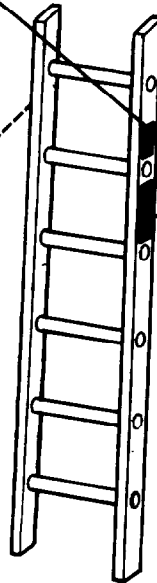
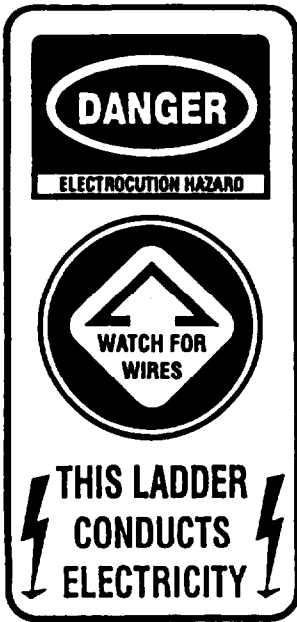
**1-13. LOCATION AND CONTENTS OF DECALS.**

The following illustrations identify the location and contents of all dolly set decals.





1-13. LOCATION AND CONTENTS OF DECALS (Con't).



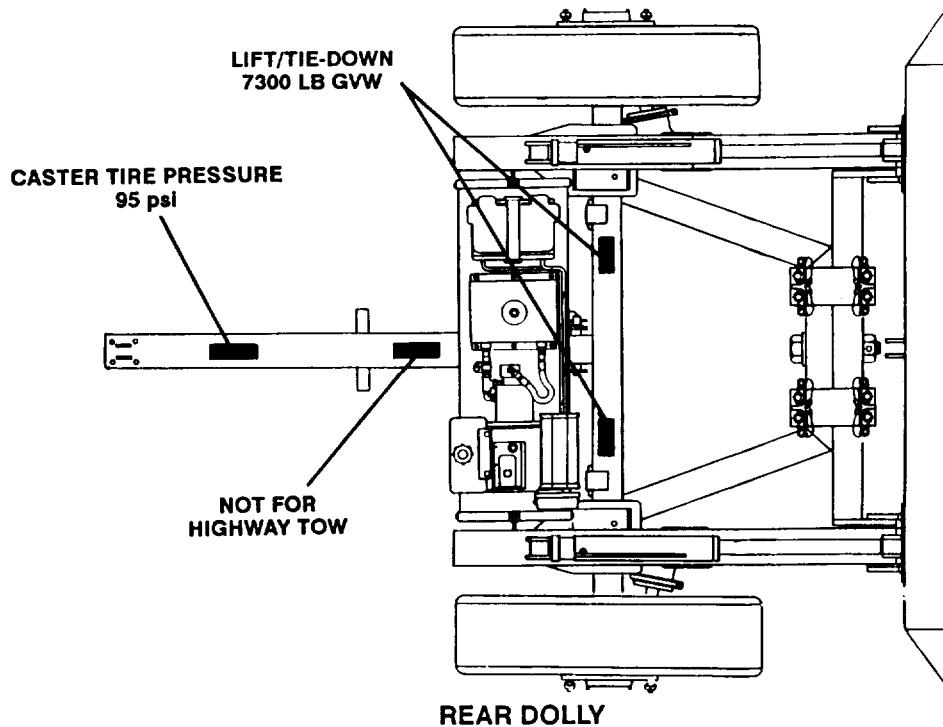
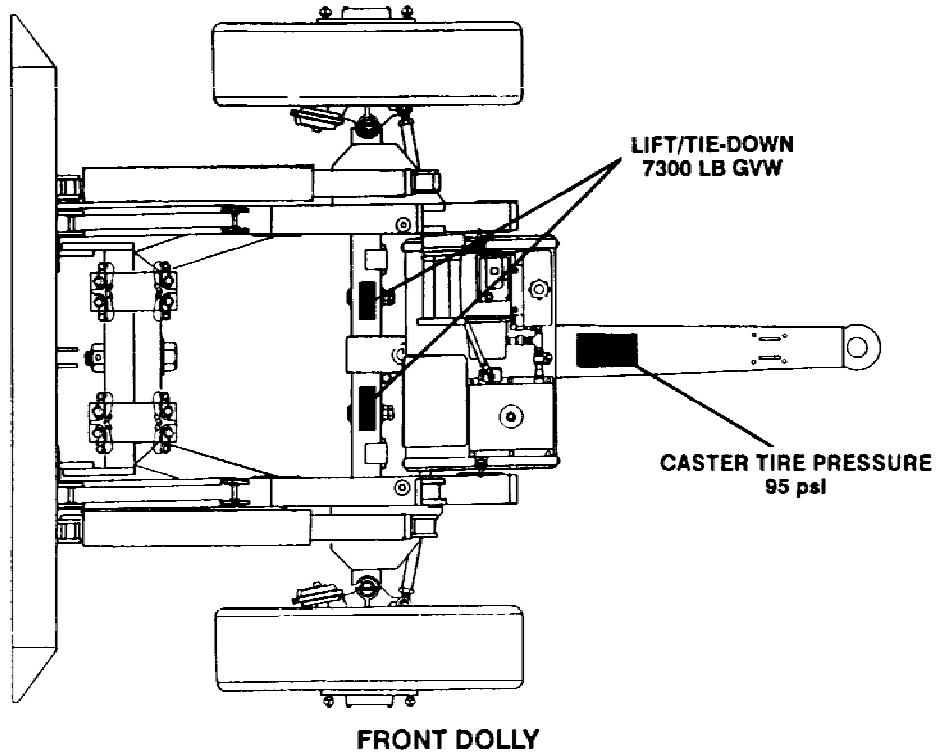
<b>NOTICE</b>
<b>LADDER SIZE</b> 7 FT.
<b>TYPE I</b> MAX LOAD 250 LBS.
Max Working Length Ft. _____ In. _____
Highest Standing Level Ft. _____ In. _____
Total Length of Sections Ft. _____ In. _____
<b>MODEL NO.</b> MT-7-12
Metallic Ladder Mfg. Corp. 41 S. Washington St. Randolph, N.Y. 14772
Date Mfg. 5/94
COMPLIES WITH ANSI A14.2 STD. FOR METAL LADDERS
<b>LIMITED WARRANTY</b>
The manufacturer warrants to the consumer that this ladder is free from defects in material and workmanship. All express and implied warranties expire 90 days after the date of purchase of the ladder. Repair or replacement at no charge upon return of the ladder to the place of manufacture. All consequential damages which result from the breach of either an express or implied warranty are hereby excluded.

---

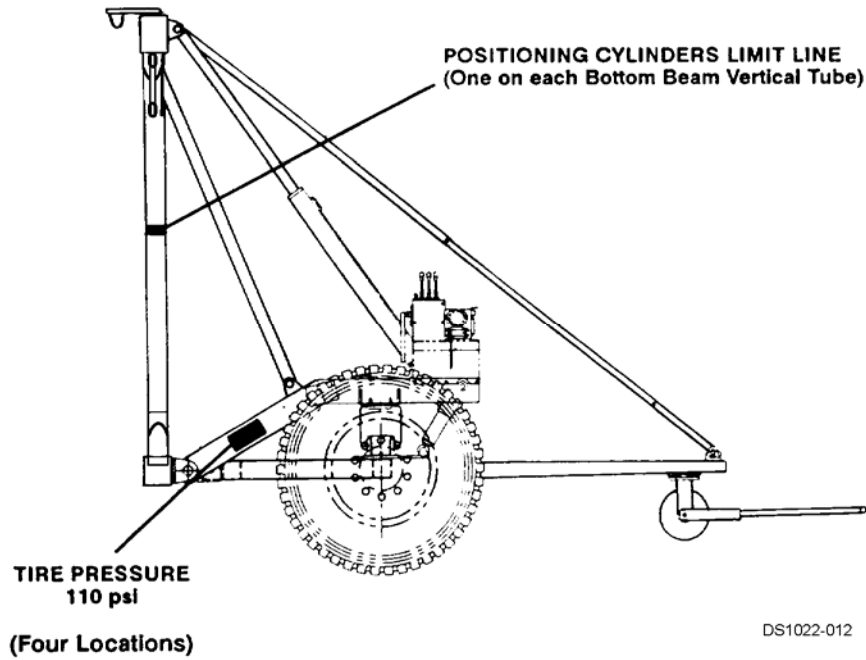
**1-14. LOCATION AND CONTENTS OF STENCILS.**

---

The following illustrations identify the location and contents of all dolly set stencils.



1-14. LOCATION AND CONTENTS OF STENCILS (Cont.)



FRONT AND REAR DOLLIES

1-15. EQUIPMENT DATA.

Table 1-2. General Characteristics and Specifications.

<b>Weight:</b>	
Dolly Set (Empty)-----	6,273 lb (2,845 kg)
Payload (Maximum) -----	15,000 lb (6,804 kg)
Gross Vehicle Weight (GVW) -----	21,273 lb (9,649 kg)
<b>Dimensions Overall</b>	
Wheel Base:	
Loaded, With 20 ft (6.1 m) Container-----	338.50 in. (859.79 cm)
Unloaded, Dolly Halves Attached -----	98.50 in. (250.19 cm)

**1-15. EQUIPMENT DATA (Con't).**

**Table 1-2. General Characteristics and Specifications (Con't).**

<b>Dimensions Overall (Con't):</b>	
Length (Front Drawbar Extended):	
Loaded, With 20 ft (6.1 m) Container . . . . .	438 in. (1112.52 cm)
Unloaded, Dolly Halves Attached . . . . .	198 in. (502.92 cm)
Height . . . . .	115.50 in. (293.37 cm)
Ground Clearance:	
End Lift Operation . . . . .	14 in. (35.56 cm)
Side Lift Operation . . . . .	58 in. (147.32 cm)
Width (Loaded or Unloaded): . . . . .	96 in. (243.84 cm)
Wheel Track (Loaded or Unloaded) . . . . .	79.75 in. (202.57 cm)
<b>Towing Specifications:</b>	
Towing Vehicle . . . . .	5 Ton Capacity or Greater
Towing Connection . . . . .	Pintle Assembly/ Lunette
Maximum Towing Speed:	
M1022A1 (End Lift Transport):	
Highway . . . . .	55 mi/h (89 km/h)
Cross-country . . . . .	25 mi/h (40 km/h)
Tandem (For Off Public Road Use Only) . . . . .	25 mi/h (40 km/h)
M1022A1 (Side Lift Transport) . . . . .	5 mi/h (8 km/h)
<b>Fording:</b>	
Depth . . . . .	Covering Wheel Hubs
<b>Fluid Capacities:</b>	
Engine:	
Crankcase Oil . . . . .	1.37 qt (1.30 I)
Fuel Tank . . . . .	Maximum Fuel Level Visible at Top of Fuel indicator
Hydraulic Reservoir:	
Standard Operation . . . . .	4.90 gl (18.55 I)
Side Lift Operation . . . . .	8.90 gl (33.69 I)

**1-15. EQUIPMENT DATA (Con't).**

**Table 1-2. General Characteristics and Specifications (Con't).**

<b>Electrical System Specifications:</b>	
Lights .....	12 V dc; 24 V dc Blackout
<b>Axie Specifications:</b>	
Front .....	Tubular, Steerable
Rear .....	Tubular, Trailer, Fixed
<b>Brake System Specifications:</b>	
Service Brakes:	
Type .....	Full Air, Wedge
Activation .....	Air Applied, Spring Retracted
Location .....	Front and Rear Dolly Wheels
Brakeshoes .....	Non-asbestos
Parking Brakes:	
Type .....	Full Air
Activation .....	Spring Applied, Air Retracted
Location .....	Rear Dolly Wheels
Emergency (Spring) Brakes:	
Type .....	Full Air
Location .....	Rear Dolly Wheels
<b>Wheel and Tire Specifications:</b>	
Wheel Size .....	20 X 7.5 (With Tube) 22.5 X 8.25 (Tubeless) Military Standard 10 Hole, 11.25 Diameter Bolt Circle
Tires:	
Size .....	11:00 X R20 (With Tube) 12:00 X R22 (Tubeless)
Quantity .....	Four
Ply Rating .....	16
Load Range .....	H
Inflation (Highway, Cross-country, or Mud) .....	110 psi (758 kPa)
Caster Wheel Assembly Tire:	
Type .....	3.40/3.00-5
Inflation .....	95 psi (655 kPa)

**1-15. EQUIPMENT DATA (Con't).**

Table 1-2. General Characteristics and Specifications (Con't).

<b>Suspension System Specifications:</b>	
Air Bags . . . . .	Four
Shock Absorbers . . . . .	Four
<b>Hydraulic System Specifications:</b>	
Fluid Type . . . . .	MIL-H-5606
Operating Pressure . . . . .	2000 psi (13,790 kPa)
Fluid Level Measurement . . . . .	Dipstick
<b>Hydraulic Pump:</b>	
Quantity . . . . .	One Each Doily Half
Type . . . . .	Gear
Rated Capacity . . . . .	2 gpm @ 2000 psi (7.57 lpm @ 13,790 kPa)
Power Source . . . . .	Engine
<b>Relief Valve:</b>	
<b>System:</b>	
Quantity . . . . .	One Each Dolly Half
Relief Valve Setting . . . . .	2000 psi (13,790 kPa)
Location . . . . .	Hydraulic Control Valve inlet
<b>Hydraulic Pump:</b>	
Quantity . . . . .	One Each Doily Half
Relief Valve Setting . . . . .	2000 psi (13,790 kPa)
Location . . . . .	Hydraulic Pump
<b>Positioning Cylinders Extension:</b>	
Quantity . . . . .	One Each Dolly Half
Relief Valve Setting . . . . .	500 psi (3448 kPa)
Location . . . . .	Hydraulic Control Valve (Positioning Cylinders Work Section)

**1-15. EQUIPMENT DATA (Con't).**

**Table 1-2. General Characteristics and Specifications (Con't).**

<b>Hydraulic System Specifications (Con't):</b>	
<b>Hydraulic Cylinders:</b>	
<b>Positioning (Without Side Lift Kit):</b>	
Quantity .....	Two Each Doily Half
Bore .....	1.50 in. (3.81 cm)
Stroke .....	48.00 in. (121.92 cm)
Rated Pressure .....	3000 psi (20,685 kPa)
<b>Positioning (With Side Lift Kit):</b>	
Quantity .....	Two Each Doily Half
Bore .....	2.00 in. (5.08 cm)
Stroke .....	68.00 in. (172.72 cm)
Rated Pressure .....	3000 psi (20,685 kPa)
<b>Lift (Without Side Lift Kit):</b>	
Quantity .....	Two Each Dolly Half
Bore .....	3.50 in. (8.89 cm)
Stroke .....	51.75 in. (131.45 cm)
Rated Pressure .....	3000 psi (20,685 kPa)
<b>Lift (With Side Lift Kit):</b>	
Type .....	Dual Action, 2-Stage
Quantity .....	Two Each Doily Half
Bore .....	5.00 in. (12.70 cm)
Stroke .....	82.00 in. (208.28 cm)
Rated Pressure .....	3000 psi (20,685 kPa)
<b>Hydraulic Control Valve:</b>	
Quantity .....	One Each Doily Half
Operation .....	Two Lift Cylinder Levers, One Positioning Cylinders Lever

**1-15. EQUIPMENT DATA (Con't).**

Table 1-2. General Characteristics and Specifications (Con't).

<b>Engine Specifications:</b>	
Model . . . . .	OC60-D1-Q or OC60-E1
Quantity . . . . .	One Each Dolly Half
Dry Weight . . . . .	83.8 lb (38.1 kg)
Type . . . . .	Diesel
Cycle . . . . .	Four
Number of Cylinders . . . . .	One
Displacement . . . . .	16.8 cu in. (275.4 cu cm)
Horsepower . . . . .	6.2 @ 3600 rpm
<b>Speed:</b>	
Maximum . . . . .	3800 rpm
Minimum (Idle) . . . . .	1200 rpm
Compression Ratio . . . . .	24.5:1
Injection Pressure (Nozzle Holder) . . . . .	2019-2133 psi (13,921-14,707 kPa)
Governor . . . . .	Centrifugal, Mechanical
Cooling System . . . . .	Oil and Air
Fuel . . . . .	Diesel DF-2 or Diesel DF-A (Arctic)
Cold Weather Starting Below 41°F (5°C) . . . . .	Glow Plug



**Section III. PRINCIPLES OF OPERATION**

Paragraph Number	Paragraph Title	Page Number
1-16.	General .....	1-30
1-17.	Electrical System .....	1-30
1-18.	Brake System .....	1-33
1-19.	Steering System .....	1-35
1-20.	Frame and Suspension Assembly .....	1-37
1-21.	Hydraulic System .....	1-39
1-22.	Engine .....	1-41

**1-16. GENERAL.**

a. The following paragraphs describe principles of operation for the major systems of the M1022A1 Dolly Set. A thorough reading of these paragraphs will be helpful to both the operator and mechanic.

b. Refer to paragraph 1-15, Equipment Data, for general characteristics and specifications as they apply to the operation and maintenance of the dolly set.

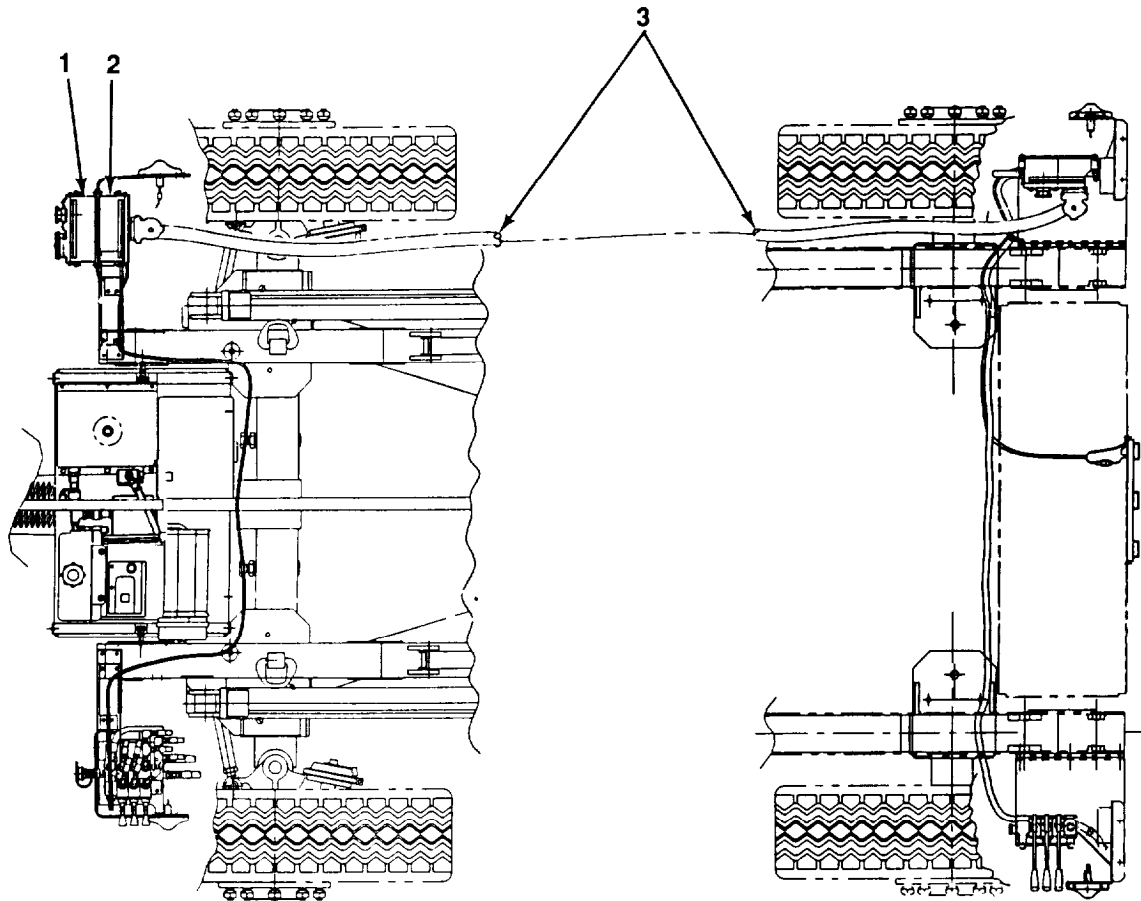
**1-17. ELECTRICAL SYSTEM.**

a. The electrical lighting system is 12 volts with adaptations for 24-volt service. The dolly set is equipped with a 12-volt and a 24-volt intervehicular cable.

b. The front dolly is equipped with marker clearance lights only. The rear dolly has marker clearance lights, an identification light, taillights (tail, stop, and turn signal lights), and 24-volt blackout stoplight-taillights.

c. Major components of the electrical system include the following:

1-17. ELECTRICAL SYSTEM (Con't).

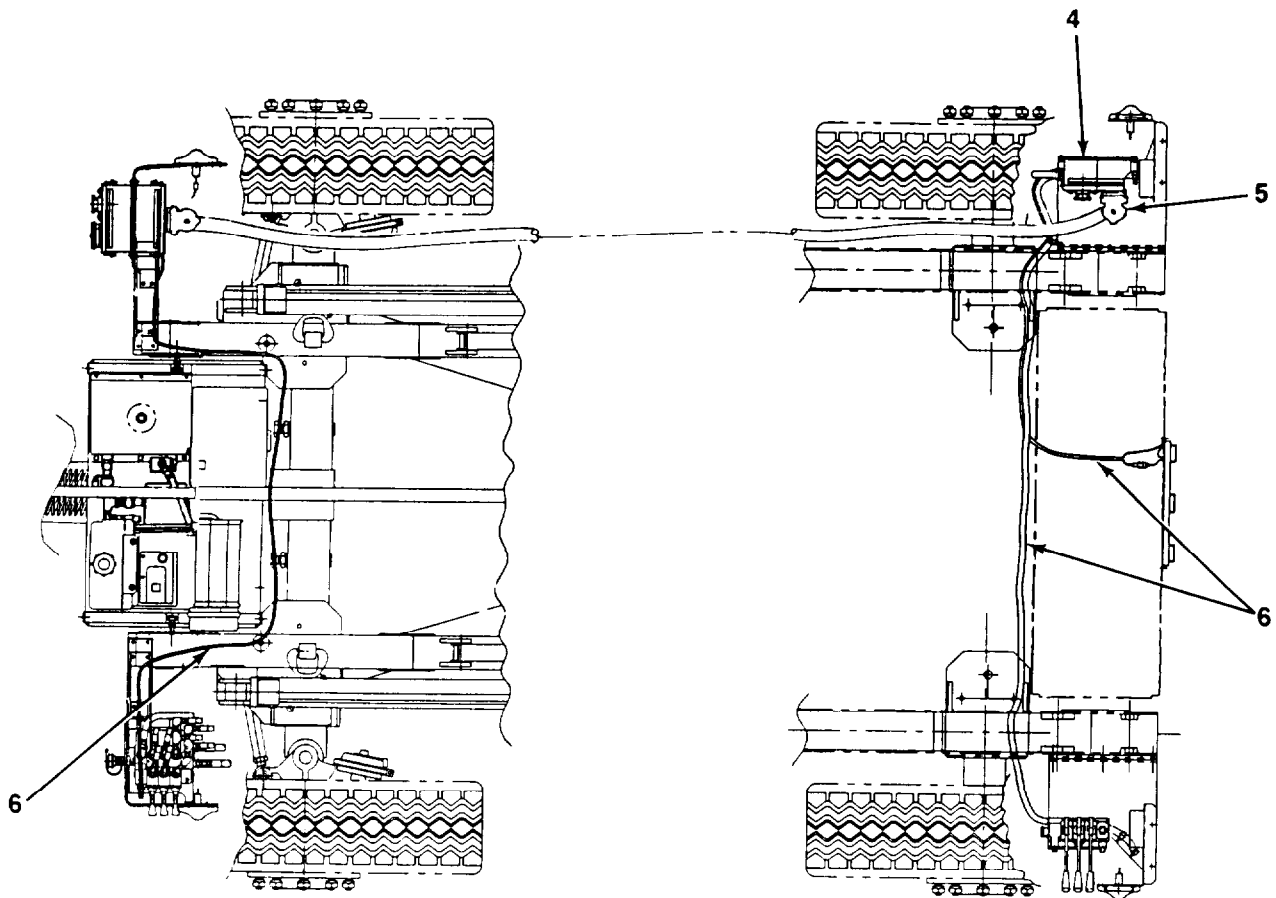


FRONT DOLLY

REAR DOLLY

Key	Component	Description
1	Signal Conditioning Box	Receives 12 volts or 24 volts from towing vehicle through intervehicular cable. Contains circuit breakers and voltage reduction circuitry to reduce 24 volts to 12 volts as required. Routes wiring to front dolly marker clearance lights and forward junction box.
2	Forward Junction Box	Receives wiring from signal conditioning box and routes wiring to 12-pin receptacle connector.
3	Intradolly Cable	Brings power from front dolly (12-pin receptacle connector in forward junction box) to rear dolly (12-pin receptacle connector in rear junction box). Is long enough to be routed over roof of a shelter.

1-17. ELECTRICAL SYSTEM (Con't).



FRONT DOLLY

REAR DOLLY

Key	Component	Description
4	Rear Junction Box	Directs power to rear dolly lights and to 12-volt receptacle connector.
5	12-volt Receptacle Connector	Provides a 12-volt connection at rear dolly.
6	Cable Assemblies	Transfer power from electrical boxes to lights.

---

## 1-18. BRAKE SYSTEM.

---

a. The brake system is a full air with wedge-type brake assemblies at each wheel. Brakeshoes are made of a non-asbestos organic compound.

b. Air to operate the brakes is supplied by the towing vehicle and is routed to the dolly set through the intervehicular and intradolly air hoses. Service supply lines are routed along the right side of the dolly set; emergency supply lines are routed along the left side.

c. The service brakes apply and release the brakes when the brake pedal in the towing vehicle is pressed during normal driving. Air to apply the brakes is directed from the air reservoirs through the relay emergency valve (front dolly) and full function valve (rear dolly) to the airbrake chambers mounted at each wheel of front and rear dollies.

d. The parking brake system operates on the rear dolly only. It applies and releases the parking brakes when the parking brake lever is operated. Spring fail-safe airbrake chambers, mounted piggyback to the service airbrake chambers on the rear dolly, allow functioning of the parking brake system.

(1) Parking brakes are applied by a large spring in the spring fail-safe airbrake chambers. The spring is normally retracted by air pressure.

(2) When the parking brake lever is raised, air pressure is removed from behind the spring and the parking brakes apply.

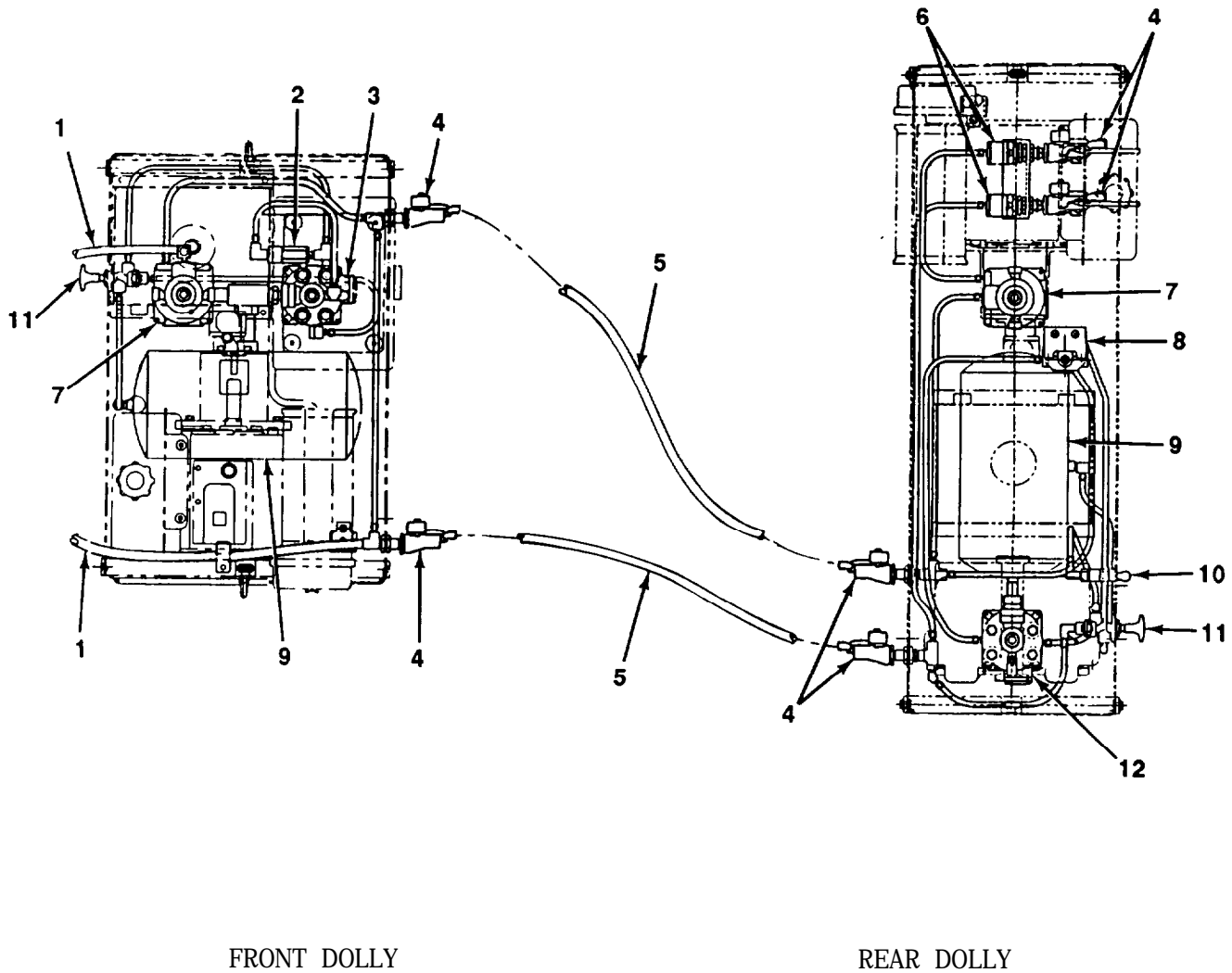
(3) Parking brakes are released by restoring air pressure to the spring fail-safe airbrake chambers to retract the spring.

e. The emergency breakaway system stops the dolly set by applying the brakes in the event that the emergency supply line from the towing vehicle is severed during a breakaway.

f. With both the parking and emergency breakaway systems, loss of air pressure causes brakes to apply. Restoration of air pressure allows brakes to release. Brakes that have been applied due to air pressure loss can be manually released (caged) to allow movement of the dolly set.

g. Major components of the brake system include the following:

1-18. BRAKE SYSTEM (Con't).



Key	Component	Description
1	Intervehicular Airbrake Hoses	Route service and emergency air from towing vehicle to front dolly.
2	Pressure Protection Valve	Acts as a check valve. Allows air to flow only one way—from emergency line to air reservoir.
3	Relay Emergency Valve	With emergency line and air reservoir pressurized, senses service brake pressure from towing vehicle and applies or releases air to service airbrake chambers to apply or release brakes.

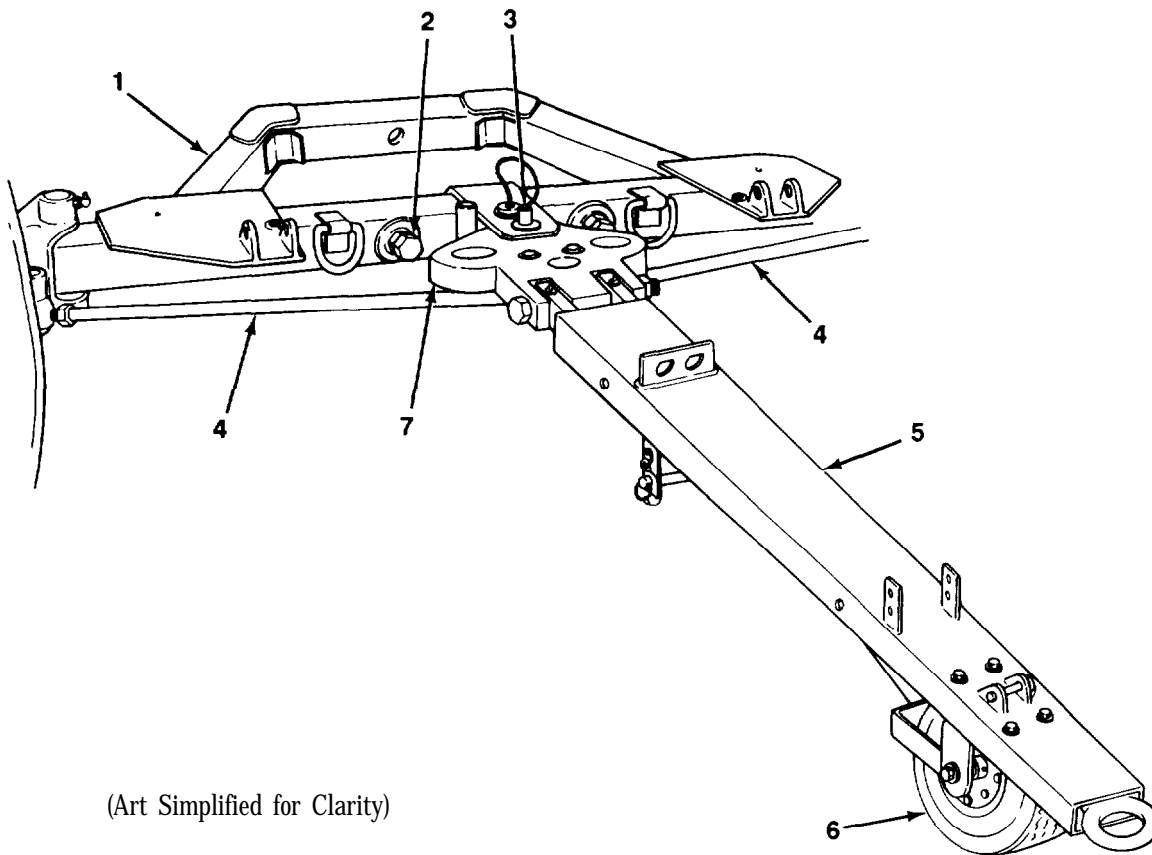
**1-18. BRAKE SYSTEM (Con't).**

Key	Component	Description
4	Pivoting Tray Gladhands	Provide quick disconnect air connections between front and rear dollies and second dolly set when towed in tandem.
5	Intradolly Airbrake Hoses	Route service and emergency air from front dolly to rear dolly.
6	Shutoff Valves (With Levers)	Open to supply air to second dolly set when tandem towing. Close when tandem towing is complete.
7	Booster Relay Valves	Provide service brake air pressure to allow proper brake operation.
8	Relay Valve	Closes service line from towing vehicle when parking brake lever on rear dolly has vented air from supply line to apply parking brakes. Prevents rear dolly service brakes from being applied at same time as parking brakes. Also prevents towing vehicle brakes from locking up.
9	Air Reservoirs	Store compressed air to operate brakes. Each reservoir has a manually operated draincock which allows release of compressed air and drainage of condensation and other contaminants from airbrake system.
10	Parking Brake Lever	Applies and releases parking brakes on rear dolly.
11	Airbrake Control Knob	Applies or releases front and rear dolly service brakes when dolly set is uncoupled from towing vehicle.
12	Full Function Valve	With emergency line and air reservoir pressurized, senses service brake pressure from towing vehicle and applies or releases air to service airbrake chambers to apply or release brakes. In addition, controls spring brakes.

**1-19. STEERING SYSTEM.**

- a. The steering system provides ground mobility when positioning front and rear dollies for attachment to a shelter. Once attached, the steering system provides similar mobility while the dolly set trailer is towed.
- b. Major components of the steering system include the following:

1-19. STEERING SYSTEM (Con't).

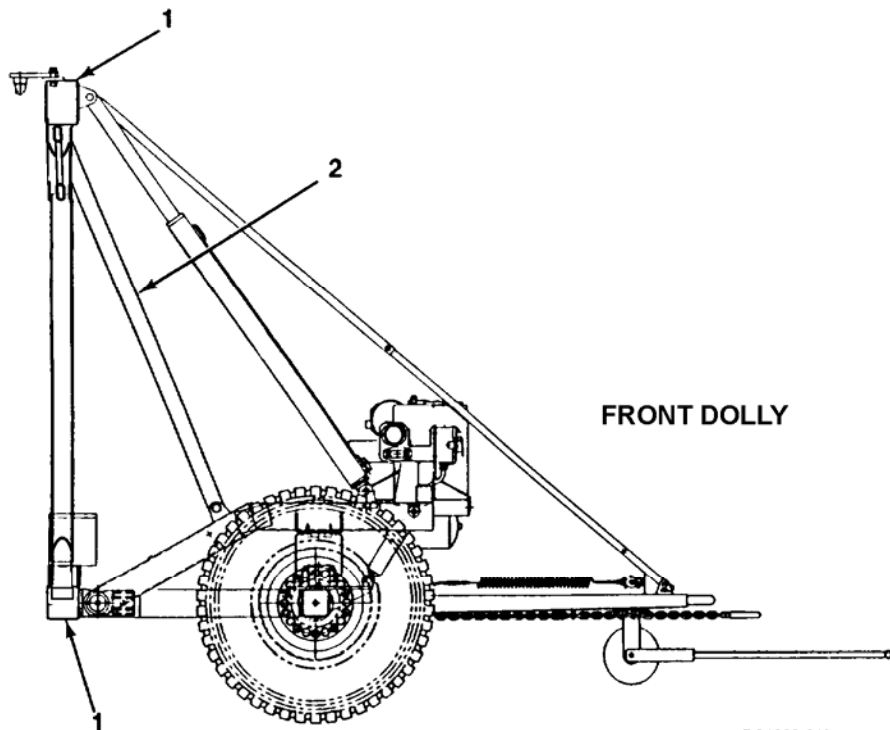


(Art Simplified for Clarity)

Key	Component	Description
1	Front Axle	Has standard vehicular steering components to provide steering capability.
2	Steering Stops	Limits steering radius.
3	Steering Locking Pin	Locks front axle steering. Used during manual positioning of front dolly to shelter and when backing dolly set in a straight line.
4	Tie-rod Assemblies	Transmit steering movement from steering link to wheels.
5	Drawbar	Used for towing, steering, and manual positioning.
6	Caster Wheel Assembly	Allows front or rear dolly to be manually moved when in a three-wheel configuration (maneuvering position).
7	Steering Link	Link at center of front axle to which tie-rod assemblies are attached.

**1-20. FRAME AND SUSPENSION ASSEMBLY.**

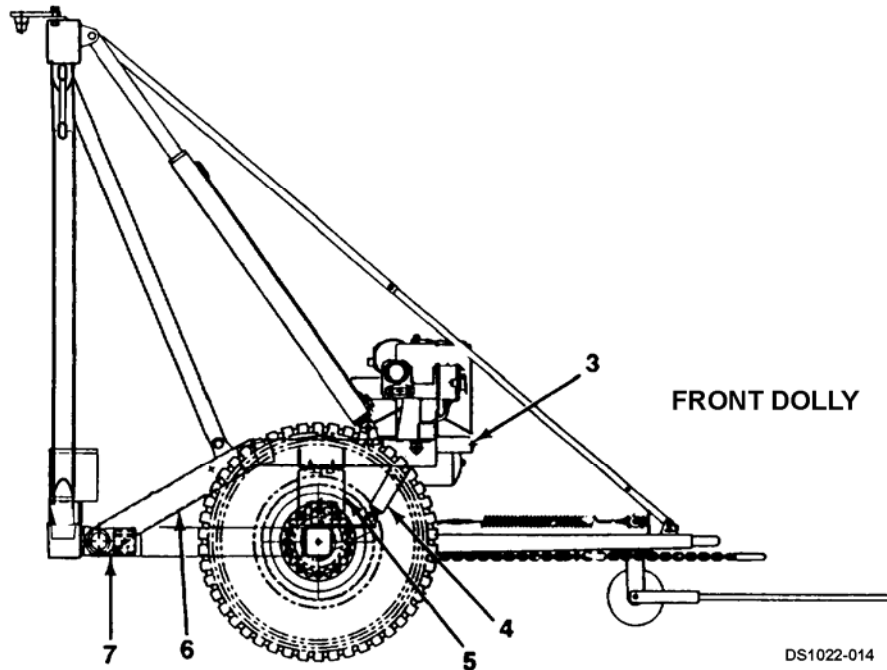
- a. Frame and suspension assembly components function together to provide:
  - (1) a means to raise, transport, and lower a shelter.
  - (2) easy positioning of each dolly half.
  - (3) cushioning and dampening effects for the dolly set and its payload.
- b. Each dolly half has its own independent frame and suspension assembly.
- c. In addition to the dolly set front and rear axles, major components of the frame and suspension assembly include the following:



Key	Component	Description
1	Top and Bottom Beams	Provide attachment point for shelter. Connected by telescoping vertical tubes which house positioning cylinders
2	Transportation Lockouts	In the event of hydraulic system failure, support dolly set and shelter during transport.



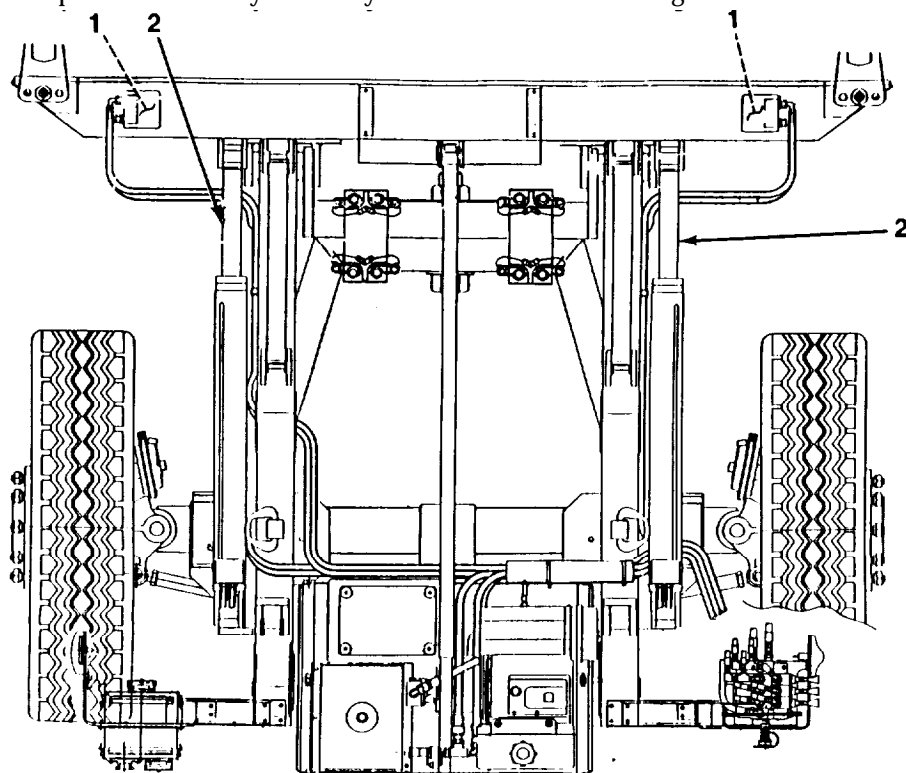
1-20. FRAME AND SUSPENSION ASSEMBLY (Cont).



Key	Component	Description
3	Pivoting Tray	Provides mounting surface for engine and other components. Must be unlocked when operating on uneven terrain and during side lift operation.
4	Shock Absorbers	Dampen road shock and provide ride height indicator rings.
5	Air Bags	Inflate to provide cushioning and proper riding height for shelter. Air bag is inflated using dolly set charging assembly (Item 1, Appendix D).
6	Suspension Links	Act as part of suspension system as well as mounts for lift cylinders, transportation lockouts, control valve and junction box brackets, and pivoting tray.
7	Pivot Axle Bracket	Locks to axle during normal operation; is unlocked when operating on uneven terrain. Allows pivoting and greater flexibility to attach to and level a shelter.

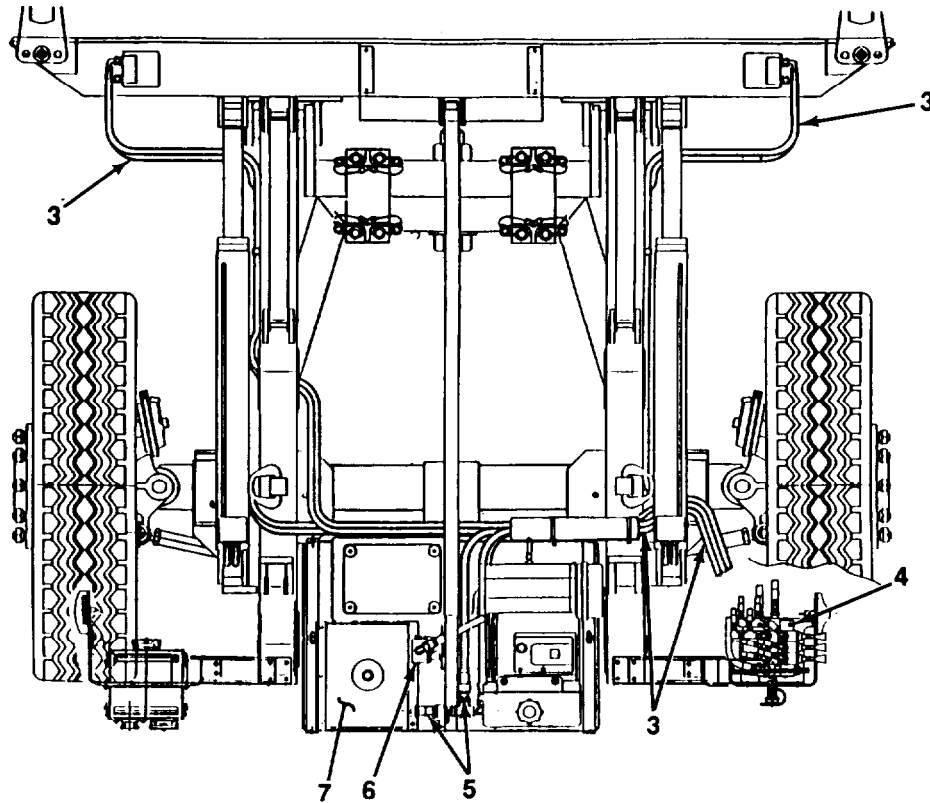
**1-21. HYDRAULIC SYSTEM.**

- a. The hydraulic system maneuvers the front and rear dolly top and bottom beams into a series of positions so that a shelter can be attached and lifted to riding height. Once towed to its destination, the hydraulic system lowers the shelter to the ground.
- b. Each dolly half has its own independent hydraulic system.
- c. Power to operate the hydraulic system comes from the engine and hydraulic pump.
- d. The hydraulic system is configured to accommodate a redundant power kit option. If either the front or rear dolly has engine or hydraulic pump failure, the other dolly half can operate both the front and rear hydraulic systems using the engine and hydraulic pump of the functioning dolly half and the redundant power kit (see paragraph 2-34).
- e. Major components of the hydraulic system include the following:



Key	Component	Description
1	Positioning Cylinders	Extend or retract to position top and bottom beams at shelters of varying dimensions. Housed inside top and bottom beam telescoping vertical tubes.
2	Lift Cylinders	Extend or retract to lift or lower shelter.

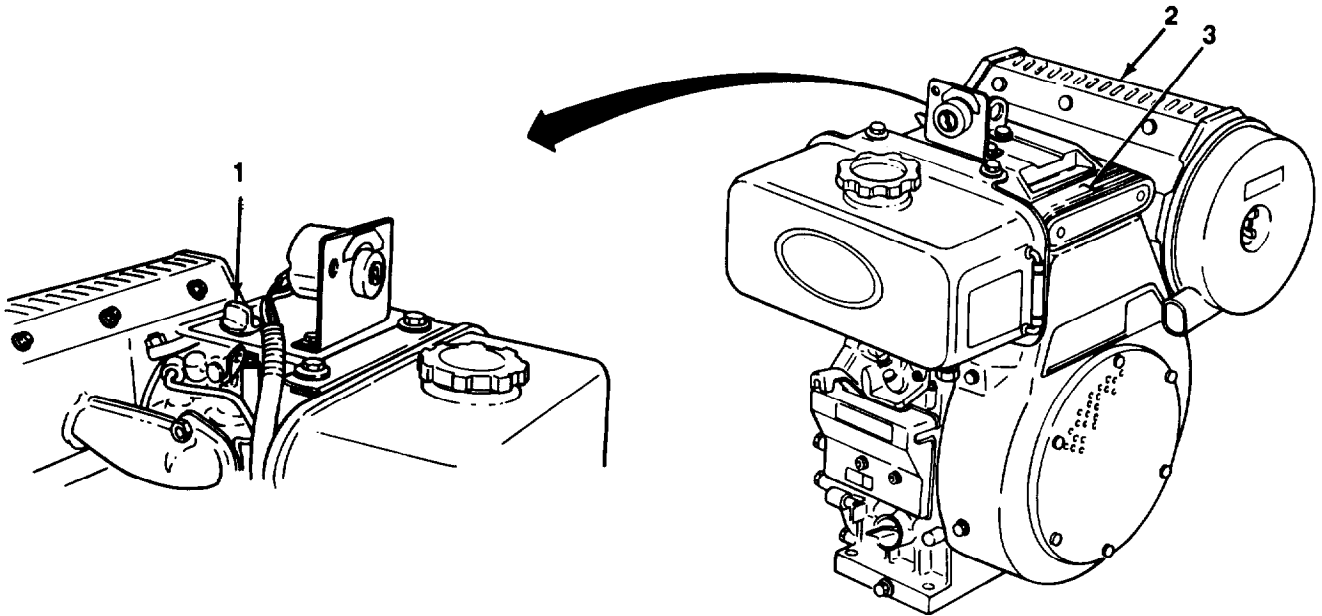
1-21. HYDRAULIC SYSTEM (Con't).



Key	Component	Description
3	Hydraulic Lines and Fittings	Provide connections between hydraulic system components.
4	Hydraulic Control Valve	Has three levers which regulate hydraulic fluid flow for operation of lift and positioning cylinders.
5	Quick Disconnect Fittings	Connection points for redundant power kit hoses during redundant power operation.
6	Hydraulic Pump	Mounted to engine and directly connected to crankshaft through a coupling. Generates an operating hydraulic pressure of 2000 psi (13,790 kPa) at 2 gpm (7.57 lpm) minimum.
7	Hydraulic Reservoir	Contains hydraulic fluid. Vented cap, with a pressure rating of 5 psi (34 kPa), has a dipstick to indicate hydraulic fluid level.

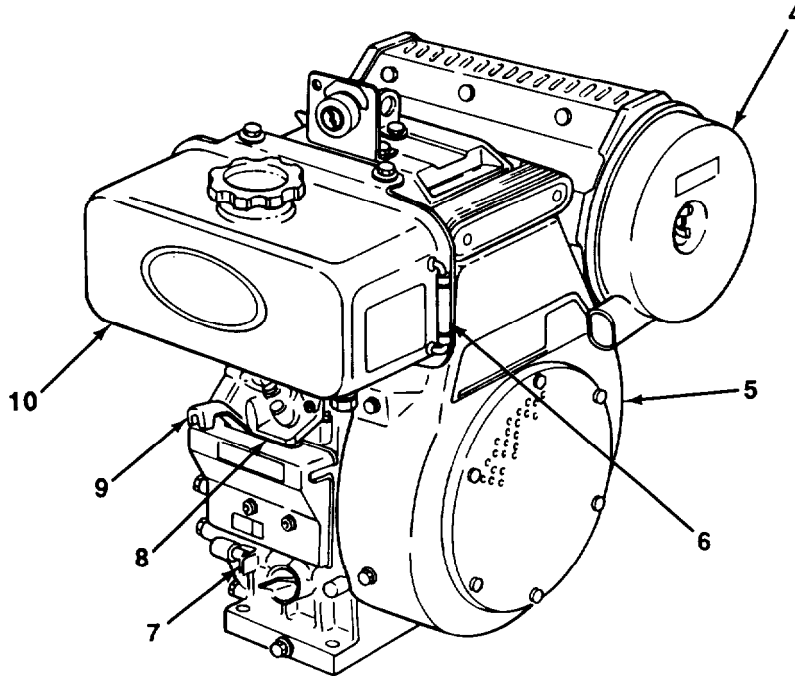
**1-22. ENGINE.**

- a. The engine is a one-cylinder, four-cycle diesel engine. It drives the dolly set hydraulic system; rotational force from the crankshaft drives the hydraulic pump.
- b. The engine is both air cooled and oil cooled.
- c. The fuel system has a low-pressure side which draws fuel from the fuel tank, through the filter, and to the injection pump. The high-pressure side (injection pump and nozzle holder) pressurizes the fuel and injects it into the combustion chamber.
- d. The mechanical-type governor controls the fuel injection. It keeps engine speed and output power at a constant level with changes in engine load.
- e. The electrical system consists of a starting system (starter, glow plug, etc.), a charging system (regulator, etc.), and a key switch. A 12-volt battery supplies the initial power to the starter.
- f. Some of the major components of the engine include the following:



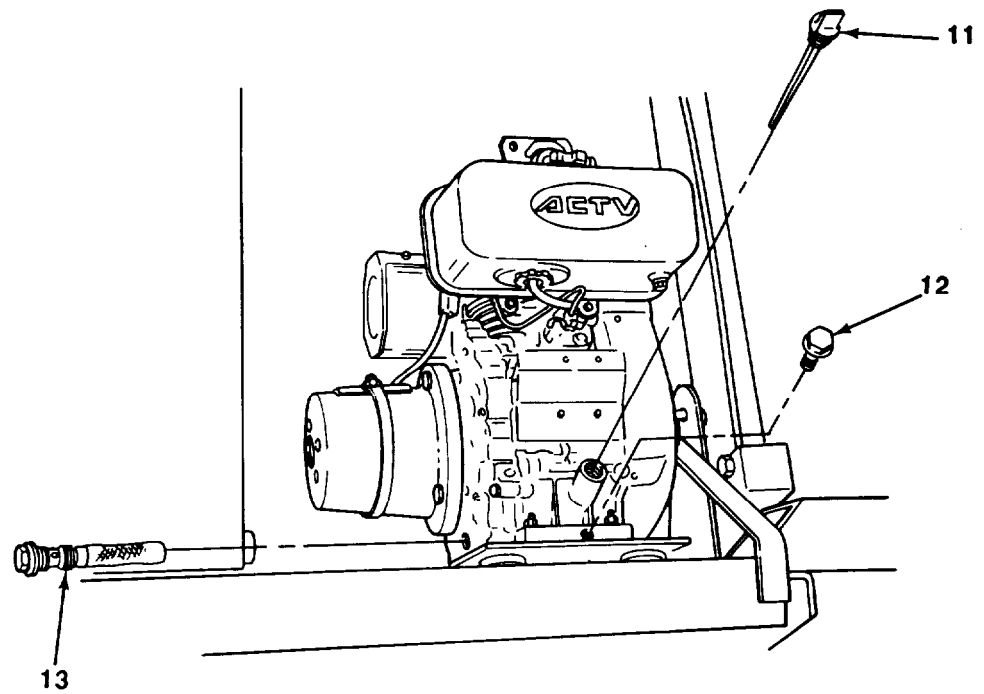
Key	Component	Description
1	Oil Filler Plug	Opens to allow addition of oil to crankcase.
2	Muffler	Reduces engine noise.
3	Oil Cooler	Consists of oil-carrying tubes and fins which function as heat exchangers to remove heat from oil.

1-22. ENGINE (Con't).



Key	Component	Description
4	Air Cleaner	Filters air at intake of engine.
5	Spiral Case (Flywheel Cover)	Covers flywheel end of engine. Is easily removed to allow cleaning of cooling fan and cylinder fins.
6	Fuel Indicator	Indicates level of fuel in fuel tank.
7	Stop Lever	Shuts down engine.
8	Injection Pump	Pressurizes fuel and sends it to nozzle holder where it is injected into combustion chamber.
9	Speed Control Lever (Throttle)	Controls engine speed.
10	Fuel Tank	Contains fuel. Has a fuel strainer inside filler opening and a fuel filter at the bottom of fuel tank.

1-22. ENGINE (Con't).



Key	Component	Description
11	Dipstick	Indicates level of oil in crankcase.
12	Drain Plug	Allows draining of crankcase oil.
13	Oil Filter	Removes contaminants from oil.



**CHAPTER 2  
OPERATING INSTRUCTIONS**

**Section I. DESCRIPTION AND USE OF OPERATOR'S  
CONTROLS AND INDICATORS**

Paragraph Number	Paragraph Title	Page Number
2-1.	General .....	2-1
2-2.	Controls and Indicators .....	2-1

**2-1. GENERAL.**

This section identifies the location and describes the function of all M1022A1 Dolly Set controls and indicators. Thoroughly review this section before operating the dolly set.

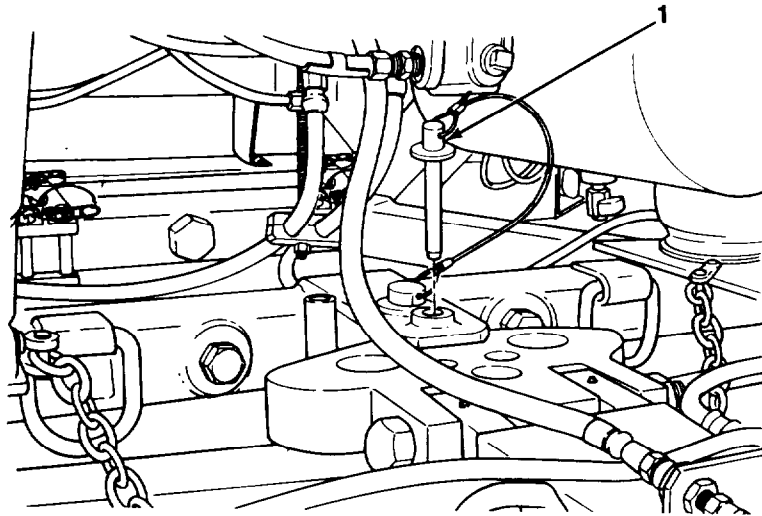
**2-2. CONTROLS AND INDICATORS.**

NOTE

Unless otherwise indicated, components are located on both front and rear dollies.

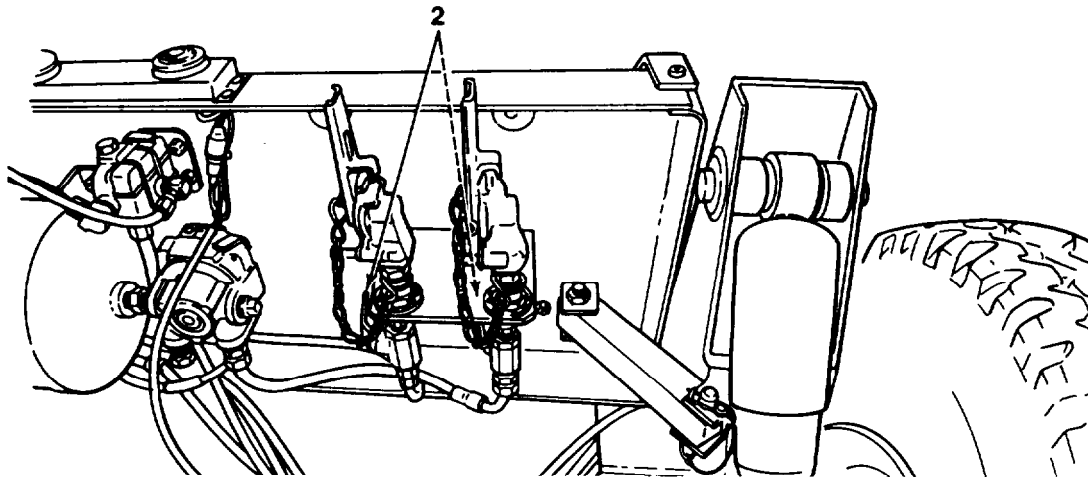


2-2. CONTROLS AND INDICATORS (Con't).



STEERING SYSTEM

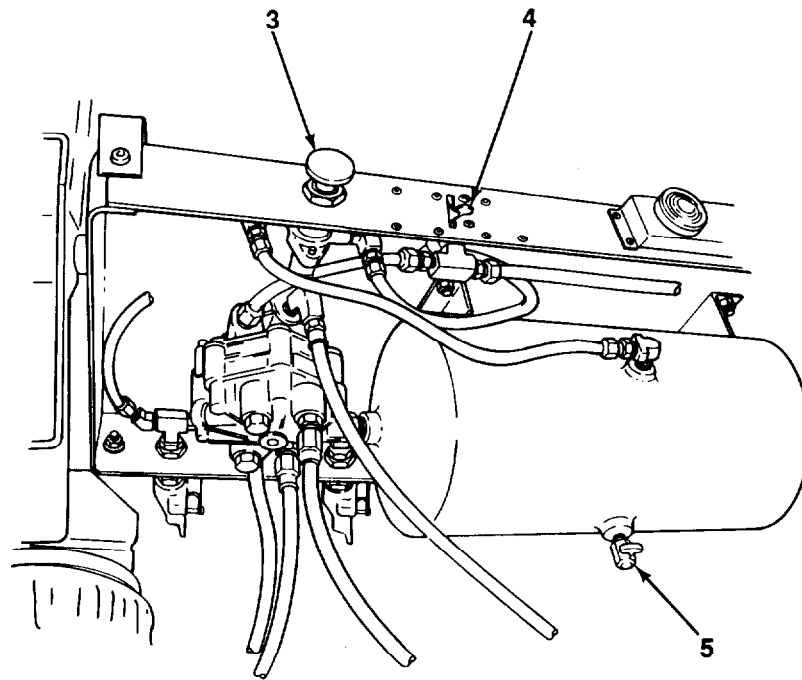
Key	Control or indicator	Function
1	Steering Locking Pin (Front Dolly)	Locks steering link to limit front drawbar side movement. Used when backing dolly set in a straight line and when operating front dolly in maneuvering position.



BRAKE SYSTEM

Key	Control or indicator	Function
2	Shutoff Valve Levers (Rear Dolly)	Opened to supply air to a second dolly set when tandem towing. Closed when tandem towing is finished.

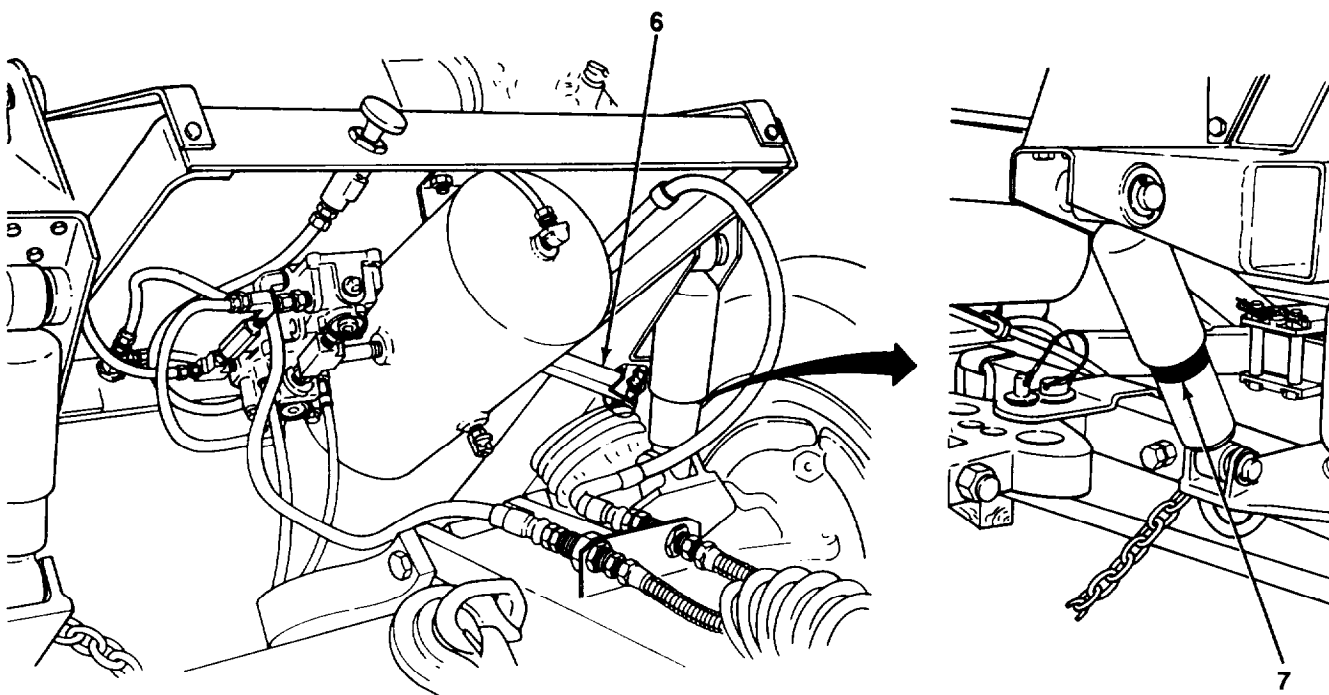
2-2. CONTROLS AND INDICATORS (Con't).



BRAKE SYSTEM

Key	Control or Indicator	Function
3	Airbrake Control Knob	Applies or releases front and rear dolly service brakes when emergency air line is disconnected from towing vehicle.
4	Parking Brake Lever (Rear Dolly)	Applies and releases parking brakes on rear dolly.
5	Air Reservoir Draincock	Releases compressed air and drains condensation and contaminants from each air reservoir.

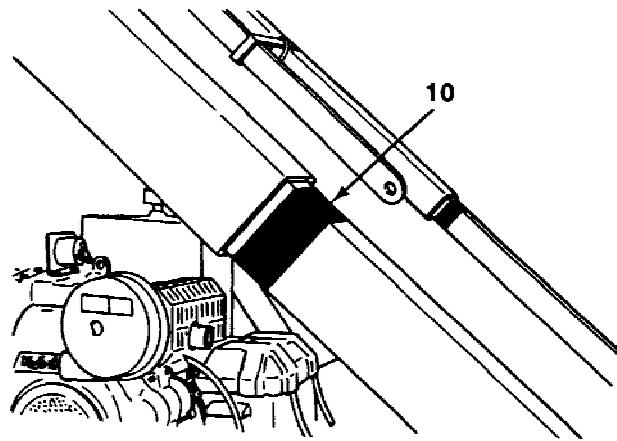
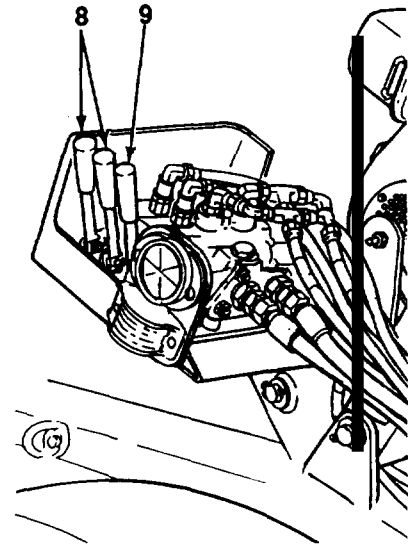
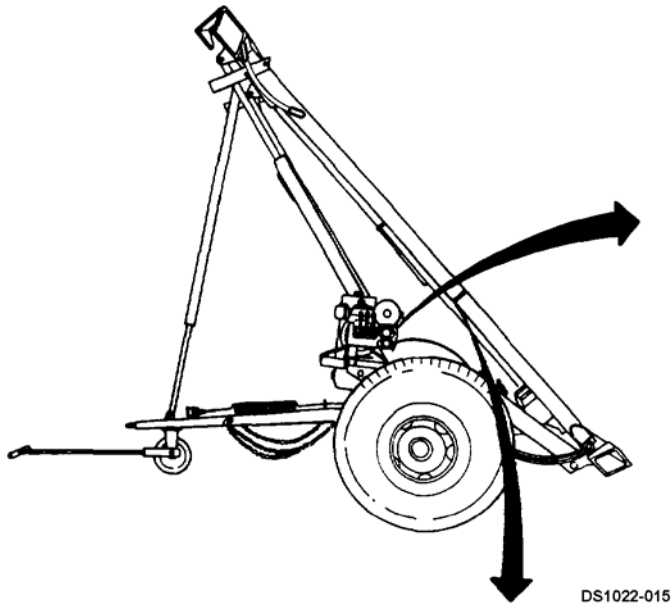
2-2. CONTROLS AND INDICATORS (Con't).



FRAME AND SUSPENSION SYSTEM

Key	Control or Indicator	Function
6	Pivoting Tray Lockout Brace	Prevents tray from pivoting during normal operation. Unlocks tray to allow pivoting when operating on uneven terrain or during side lift operation.
7	Ride Height Indicator Ring	Indicates correct dolly set riding height. Located on each shock absorber.

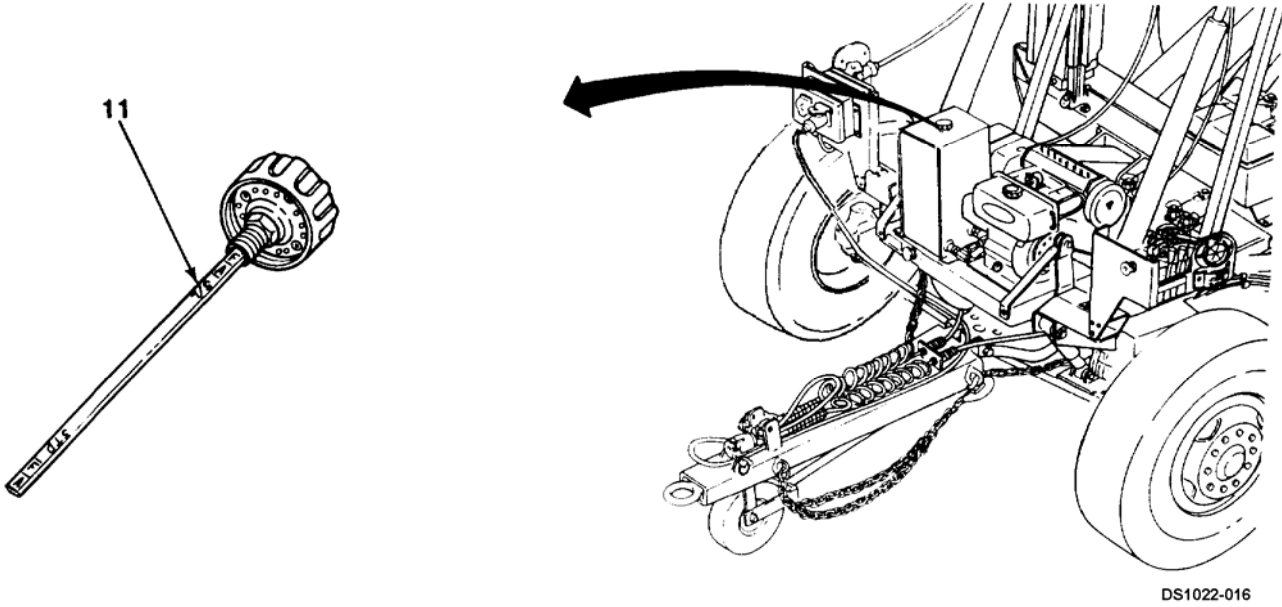
2-2. CONTROLS AND INDICATORS (Con't).



HYDRAULIC SYSTEM

Key	Control or indicator	Function
8	Lift Cylinder Levels	Operate lift cylinders.
9	Positioning Cylinders Lever	Operates both positioning cylinders in unison.
10	Positioning Cylinders Limit Line	Indicates maximum extension of positioning cylinders when placing dolly half in maneuvering position (side lift configuration only).

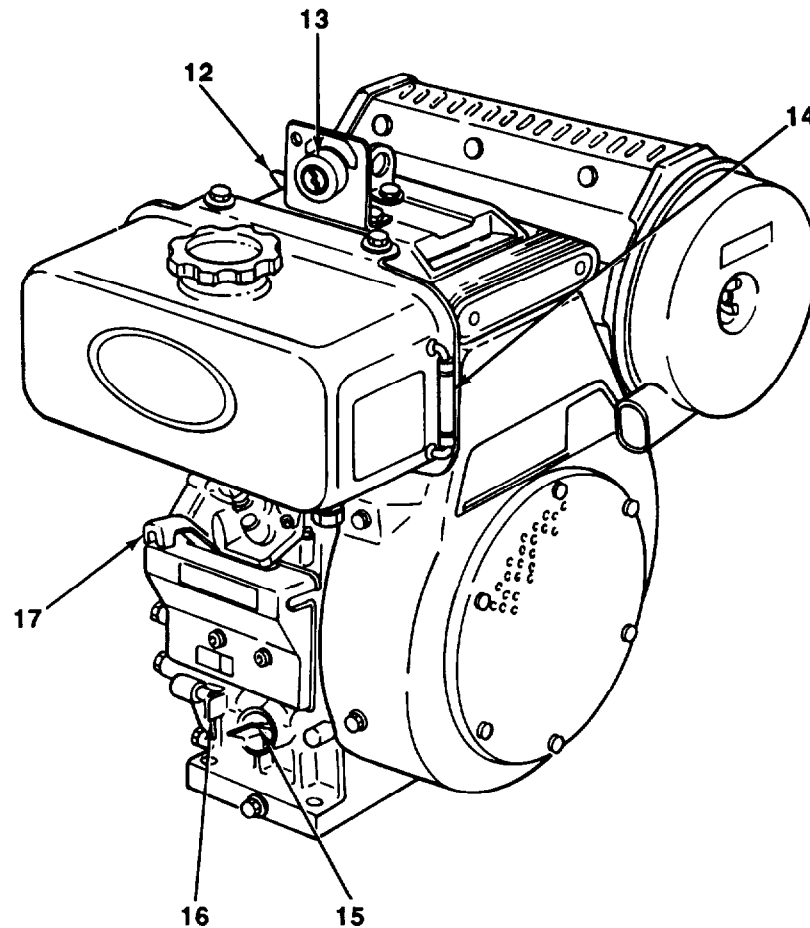
2-2. CONTROLS AND INDICATORS (Con't).



HYDRAULIC SYSTEM

Key	Control or indicator	Function
11	Dipstick	Indicates level of hydraulic fluid in hydraulic reservoir. Includes both standard (STD) and side lift (S/L) add (A) and full (F) marks.

2-2. CONTROLS AND INDICATORS (Con't).



Key	Control or Indicator	Function
12	Decompression Lever	Assists in starting of engine.
13	Starter Switch	Assists engine starting. Is a four-position key-operated switch with OFF, ON, GL (glow plug), and ST (start) positions.
14	Fuel Indicator	Indicates level of fuel in fuel tank.
15	Dipstick	Indicates level of oil in crankcase.
16	Stop Lever	Shuts down engine.
17	Speed Control Lever (Throttle)	Controls engine speed. Is a two-position lever with LOW and HIGH START positions.

## Section II. OPERATOR/CREW PREVENTIVE MAINTENANCE CHECKS AND SERVICES (PMCS)

Paragraph Number	Paragraph Title	Page Number
2-3.	General.....	2-8
2-4.	Explanation of Table Entries.....	2-8
2-5.	General PMCS Procedures.....	2-9
Table 2-1.	Operator/Crew Preventive Maintenance Checks and Services (PMCS).....	2-10

---

### 2-3. GENERAL.

---

To ensure that the M1022A1 Dolly Set is ready for operation at all times, it must be inspected on a regular basis so that defects may be found before they result in serious damage, equipment failure, or injury to personnel. Table 2-1 contains systematic instructions on inspections, adjustments, and corrections to be performed by Operator/Crew Maintenance to keep your equipment in good operating condition and ready for its primary mission.

---

### 2-4. EXPLANATION OF TABLE ENTRIES.

---

a. Item Number (Item No.) Column. Numbers in this column are for reference. When completing DA Form 2404 (Equipment inspection and Maintenance Worksheet), include the item number for the check/service indicating a fault. Item numbers also appear in the order that you must perform checks and services for the interval listed.

b. Interval Column. This column tells you when you must perform the procedure in the procedure column.

(1) Before procedures must be done before you operate or use the equipment for its intended mission.

(2) During procedures must be done during the time you are operating or using the equipment for its intended mission.

(3) After procedures must be done immediately after you have operated or used the equipment.

(4) Weekly procedures must be done once each week.

c. Location, Item To Check/Service Column. This column identifies the location and the item to be checked or serviced. The item location is underlined.

#### NOTE

**The WARNINGS and CAUTIONS appearing in your PMCS table should always be observed. WARNINGS and CAUTIONS appear before applicable procedures. These WARNINGS and CAUTIONS must be observed to prevent serious injury to yourself and others or to prevent your equipment from being damaged.**

d. Procedure Column. This column gives the procedure you must perform to check or service the item listed in the Item To Check/Service column to know if the equipment is ready or available for its intended mission or for operation. You must perform the procedure at the time stated in the interval column.

---

## 2-4. EXPLANATION OF TABLE ENTRIES (Con't).

---

e. **Not Fully Mission Capable If: Column.** Information in this column tells you what faults will keep your equipment from being capable of performing its primary mission. If you make check and service procedures that show faults listed in this column, do not operate the equipment. Follow standard operating procedures for maintaining the equipment or reporting equipment failure.

---

## 2-5. GENERAL PMCS PROCEDURES.

---

a. Always perform PMCS in the same order so it gets to be a habit. Once you've had some practice, you'll spot anything wrong in a hurry. If the dolly set does not perform as required, refer to the appropriate troubleshooting task in Chapter 3, Section II.

b. If anything looks wrong and you can't fix it, write it on your DA Form 2404. If you find something seriously wrong, IMMEDIATELY report it to your supervisor.

c. Before performing preventive maintenance, read all the checks required for the applicable interval and prepare all tools needed to make all checks. Have several clean rags (item 25, Appendix F) handy. Perform ALL inspections at the applicable interval.



Dry cleaning solvent, P-D-680, is toxic and flammable. Always wear protective goggles and gloves, and use only in a well-ventilated area. Avoid contact with skin, eyes, and clothes, and DO NOT breathe vapors. DO NOT use near open flame or excessive heat. The solvent's flash point is 100°F-138°F (38°C-59°C). If you become dizzy while using cleaning solvent, immediately get fresh air and medical help. If solvent contacts eyes, Immediately wash your eyes and seek medical attention.

(1) **Keep It Clean.** Dirt, grease, oil, and debris get in the way and may cover up a serious problem. Clean as you work and as needed. Use dry cleaning solvent (Item 27, Appendix F) on all metal surfaces. Use dishwashing compound (Item 7, Appendix F) and water when you clean rubber, plastic, and painted surfaces.

(2) **Rust and Corrosion.** Check metal parts of dolly set and frame for rust and corrosion. If any bare metal or corrosion exists, clean and apply a light coat of lubricating oil (Item 23, Appendix F). Report it to your supervisor.

(3) **Bolts, Nuts, and Screws.** Check bolts, nuts, and screws for obvious looseness, missing, bent, or broken condition. You can't try them all with a tool, of course, but look for chipped paint, bare metal, or rust around bolt heads. If you find one you think is loose, report it to your supervisor.

(4) **Welds.** Look for loose or chipped paint, rust, or gaps where pans are welded together. If you find a bad weld, report it to your supervisor.

(5) **Electric Wires and Connectors.** Look for cracked or broken insulation, bare wires, and loose or broken connectors. Tighten loose connectors and ensure that the wires are in good condition.



**2-5. GENERAL PMCS PROCEDURES (Con't).**

(6) Air and Hydraulic Hoses and Lines. Look for wear, damage, and signs of leaks. Ensure that clamps and fittings are tight. Wet spots indicate leaks, of course, but a stain around a fitting or connector can also mean a leak. If a leak comes from a loose fitting or connector, tighten it. If something is broken or worn out, report it to your supervisor.

(7) Fluid Leakage. It is necessary for you to know how fluid leakage affects the status of your dolly set. The following are definitions of the types/classes of leakage you need to know to be able to determine whether or not the dolly set is mission-capable. Learn and be familiar with them, and remember - when in doubt, notify your supervisor!

**CAUTION**

Equipment operation is allowable with minor (Class I or II) leakage. Fluid levels in an item/system affected with such leakage must be checked more frequently than required in PMCS. Parts without fluid will stop working or may be damaged. When in doubt, notify your supervisor. IMMEDIATELY report Class III leaks to Unit Maintenance.

Leakage Definitions for Operator/Crew PMCS

- Class I . . . . . Seepage of fluid (as indicated by wetness or discoloration) not great enough to form drops.
- Class II . . . . . Leakage of fluid great enough to form drops, but not enough to cause drops to drip from the item being inspected.
- Class III . . . . . Leakage of fluid great enough to form drops that fall from the item being inspected.

Table 2-1. Operator/Crew Preventive Maintenance Checks and Services (PMCS).

Item No.	Interval	Location	Procedure	Not Fully Mission Capable If:
		Item To Check/Service		
			<p>NOTE</p> <ul style="list-style-type: none"> <li>• Review all WARNINGS, CAUTIONS, and NOTES before performing Operator/Crew PMCS and operating the dolly set.</li> <li>• Perform all Operator/Crew PMCS if:                             <ul style="list-style-type: none"> <li>a. You are the assigned operator but have not operated the dolly set since the last Weekly Inspection.</li> <li>b. You are operating the dolly set for the first time.</li> </ul> </li> </ul>	

Table 2-1. Operator/Crew Preventive Maintenance Check and Services (PMCS) (Cont).

Item No.	Interval	Location	Procedure	Not Fully Mission Capable If:
		Item to Check/Service		
1	Before	FRONT	a. Check under front dolly for evidence of fluid leakage.  b. Check for obvious damage to front dolly that would impair operation.	a. Class III hydraulic fluid or oil leakage is evident. Class II fuel leakage is evident.  b. Front dolly damage impairs operation.
		Overall View		
2	Before	Front Drawbar	a. Check for damage to lunette (9), front drawbar (7), caster wheel assembly (8), and safety chains (6) that would impair operation.  b. Check for damage to intervehicular air hoses (4), gladhands (2), and preformed packings (3).	a. Parts are missing or damage to pans impairs operation.  b. Breaks or cuts are found. Preformed packings are damaged or missing.
			c. Check for damage to intervehicular cable (1). Ensure that intervehicular cable is securely connected to signal conditioning box (5).	c. Intervehicular cable is missing or damaged.

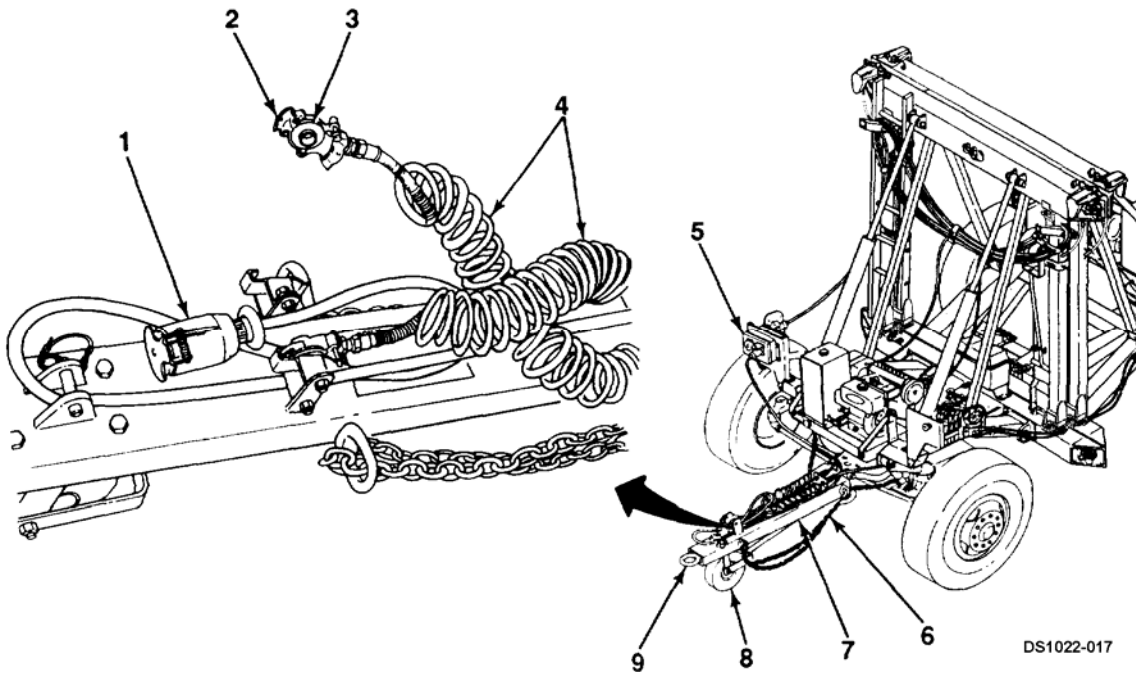
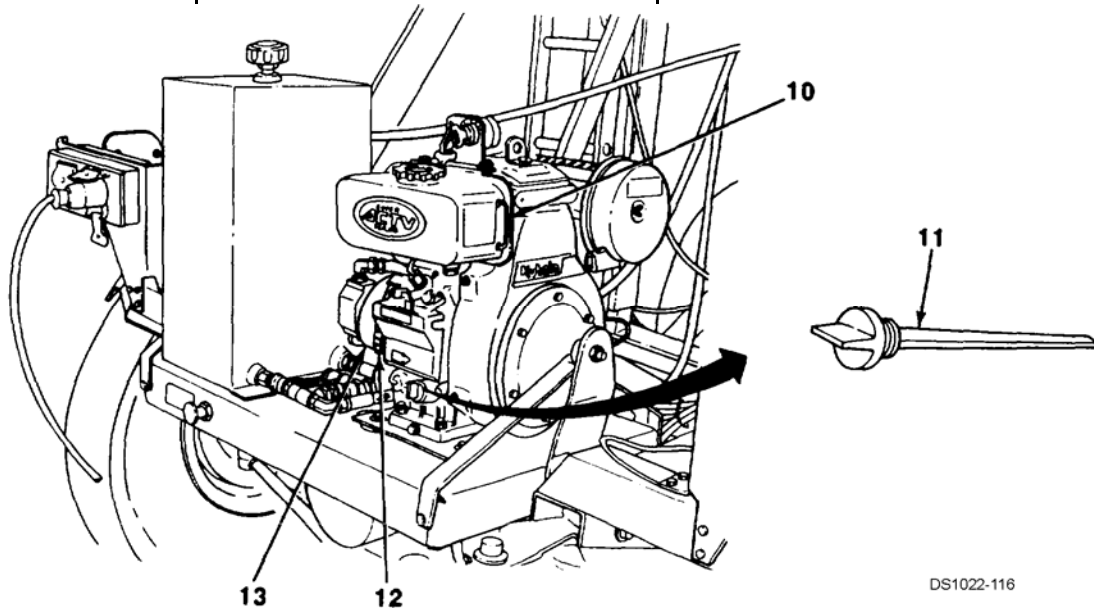


Table 2-1. Operator/Crew Preventive Maintenance Check and Services (PMCS) (Cont).

Item No.	Interval	Location	Procedure	Not Fully Mission Capable If:
		Item to Check/Service		
3	Before	Engine	<p style="text-align: center;"><b>CAUTION</b></p> <p>Use caution not to damage threads of dipstick.</p> <p>a. Check crankcase oil level (see paragraph 3-8). Oil level is FULL if oil coats threads of dipstick (11). Add oil as required (see Lubrication instructions, Chapter 3, Section I).</p> <p>b. Visually check level of fuel through fuel indicator (10). Maximum fuel level height should be just visible at top of fuel indicator. Add fuel as required (see paragraph 3-9).</p>	<p style="text-align: center;"><b>NOTE</b></p> <p>Operation is possible if equipped with redundant power kit.</p> <p>a. Dipstick is missing.</p>
4	Before	Hydraulic Pump	<p>Check that access cover is installed on hydraulic pump adapter (13) and is secured with hose clamp (12).</p>	



DS1022-116

Table 2-1. Operator/Crew Preventive Maintenance Check and Services (PMCS) (Cont).

Item No.	Interval	Location	Procedure	Not Fully Mission Capable If:
		Item to Check/Service		
5	Before	Battery and Cables	<p style="text-align: center;"><b>CAUTION</b></p> <p><b>Avoid overtightening strap, which may damage strap or buckle.</b></p> <p>Unfasten strap (14) and remove cover (15) from battery case (19). Check for damage to battery (16). Ensure that battery cables (18) are securely connected. Install cover and fasten strap.</p>	Battery or cables are missing or damaged,
6	Before	Pivoting Tray Airbrake Components and Intradolly Air Hoses	<p>a. Check for damage to intradolly air hoses (17), gladhands (2), and preformed packings (3).</p> <p>b. Check that air reservoir drain cock (20) is closed.</p>	Intradolly air hoses, gladhands or preformed packings are damaged or missing.

Table 2-1. Operator/Crew Preventive Maintenance Check and Services (PMCS) (Cont).

Item No.	Interval	Location	Procedure	Not Fully Mission Capable If:
		Item to Check/Service		
7	Before	LEFT SIDE	Check for damage to levers (26) at front dolly.	Levers at front dolly are damaged or missing.
		Hydraulic Control Valve		
<p style="text-align: right;">DS1022-018</p>				
8	Before	Tire and Wheel Assemblies	<p>a. Check tires for underinflation and condition.</p> <p style="text-align: center;"><b>NOTE</b></p> <p><b>After initial 50-100 hours of operation, notify Unit Maintenance to check torque and retighten wheel lug nuts to proper torque.</b></p> <p>b. Check wheel lug nuts for looseness. If loose, tighten. Notify Unit Maintenance to apply final torque.</p>	<p>a. Tire is missing, deflated or unserviceable.</p> <p>b. Two or more lug nuts are missing.</p>

Table 2-1. Operator/Crew Preventive Maintenance Check and Services (PMCS) (Cont).

Item No.	Interval	Location	Procedure	Not Fully Mission Capable If:
		Item to Check/Service		
9	Before	Transportation Lockouts and Rear Drawbar	a. Check condition of transportation lockouts (24). b. Check for condition and secure stowage of rear drawbar (22) on bottom beam (25).	a. Transportation lockouts are missing or damaged. b. Rear drawbar is missing or damaged.
10	Before	Twist Locks	Check that twist locks (23) at top beam (21) and bottom beam (25) are present and secure.	Twist lock is missing.
10.1	Before	Lift Cylinders	If lift cylinder rods (20.1) are dusty or dirty, wipe down with a rag lightly oiled with lubricating oil (Item 23, Appendix F).	
11	Before	Hydraulic Control Valve	Check for damage to levers (26) at rear dolly.	Levers at rear dolly are damaged or missing.
12	Before	Pivoting Tray Gladhands and Intradolly Air Hoses	Check for damage to intradolly air hoses (17), gladhands (2), and preformed packings (3).	Intradolly air hoses, gladhands or preformed packings are damaged or missing.

Table 2-1. Operator/Crew Preventive Maintenance Check and Services (PMCS) (Cont).

Item No.	Interval	Location	Procedure	Not Fully Mission Capable If:
		Item to Check/Service		
13	Before	REAR	<p>a. Check under rear dolly for evidence of fluid leakage.</p> <p>b. Check for obvious damage to front dolly that would impair operation.</p> <div style="border: 1px solid black; padding: 5px; text-align: center; margin: 10px 0;"><b>CAUTION</b></div> <p><b>Avoid overtightening strap, which may damage strap or buckle.</b></p>	<p>a. Class III hydraulic fluid or oil leakage is evident. Class II fuel leakage is evident.</p> <p>b. Rear dolly damage impairs operation.</p>
		Overall View		
14	Before	Battery and Cables	<p>Unfasten strap (14) and remove cover (15) from battery case (19). Check for damage to battery (16). Ensure that battery cables (18) are securely connected. Install cover and fasten strap.</p>	<p>Battery or cables are missing or damaged.</p>

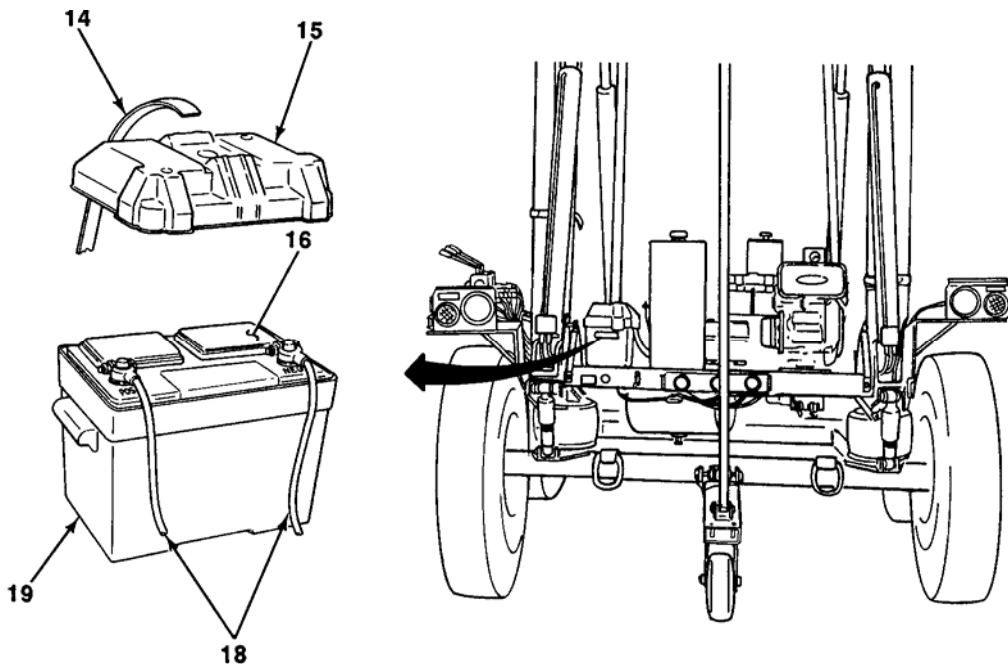


Table 2-1. Operator/Crew Preventive Maintenance Check and Services (PMCS) (Cont).

Item No.	Interval	Location	Procedure	Not Fully Mission Capable If:
		Item to Check/Service		
15	Before	Engine	<p style="text-align: center;"><b>CAUTION</b></p> <p>Use caution not to damage threads of dipstick.</p> <p>a. Check crankcase oil level (see paragraph 3-8). Oil level is FULL if oil coats threads of dipstick (11). Add oil as required (see Lubrication instructions, Chapter 3, Section I).</p> <p>b. Visually check level of fuel through fuel indicator (10). Maximum fuel level height should be just visible at top of fuel indicator. Add fuel as required (see paragraph 3-9).</p>	<p style="text-align: center;"><b>NOTE</b></p> <p>Operation is possible if equipped with redundant power kit.</p> <p>a. Dipstick is missing.</p>
16	Before	Hydraulic Pump	<p>Check that access cover is installed on hydraulic pump adapter (13) and is secured with hose clamp (12).</p>	

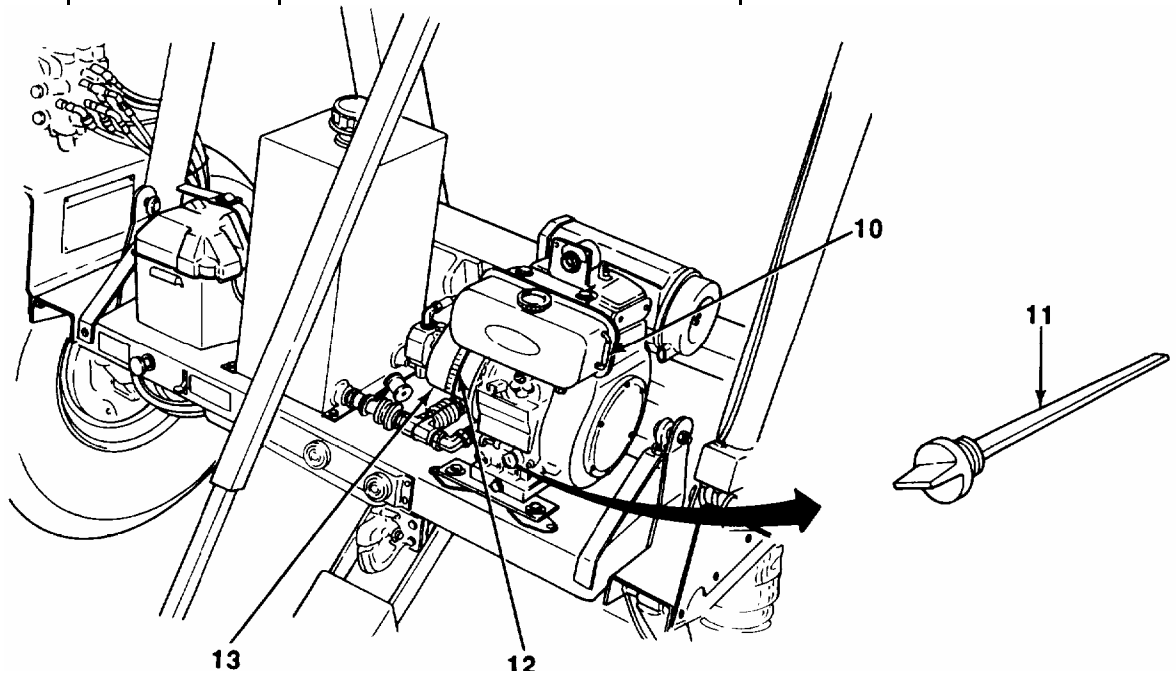




Table 2-1. Operator/Crew Preventive Maintenance Check and Services (PMCS) (Cont).

Item No.	Interval	Location	Procedure	Not Fully Mission Capable If:
		Item to Check/Service		
17	Before	<b>Pivoting Tray Airbrake Components and Intradolly Air Hoses</b>	a. Check for damage to intradolly air hoses (17), gladhands (2), and preformed packings (3). b. Check that air reservoir draincock (20) is closed.	a. Gladhands or preformed packings are damaged or missing.
18	Before	<b>Rear Electrical Installation</b>	a. Check for damage to rear junction box (29) receptacle connectors (30), and cable assemblies (28).	a. Rear junction box, receptacle connectors, or cable assemblies are damaged.

Table 2-1. Operator/Crew Preventive Maintenance Check and Services (PMCS) (Cont).

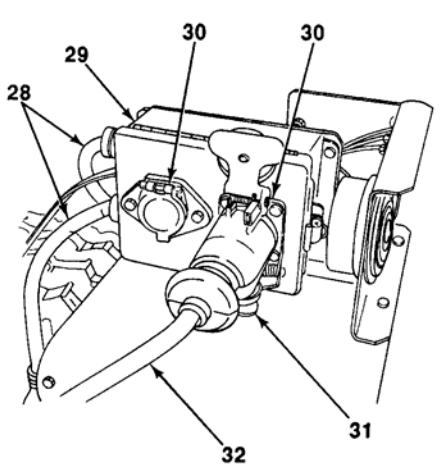
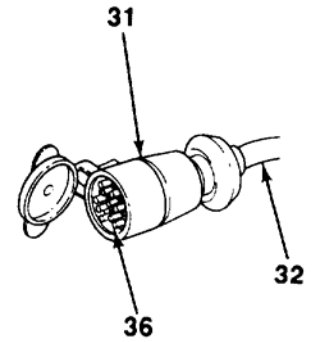
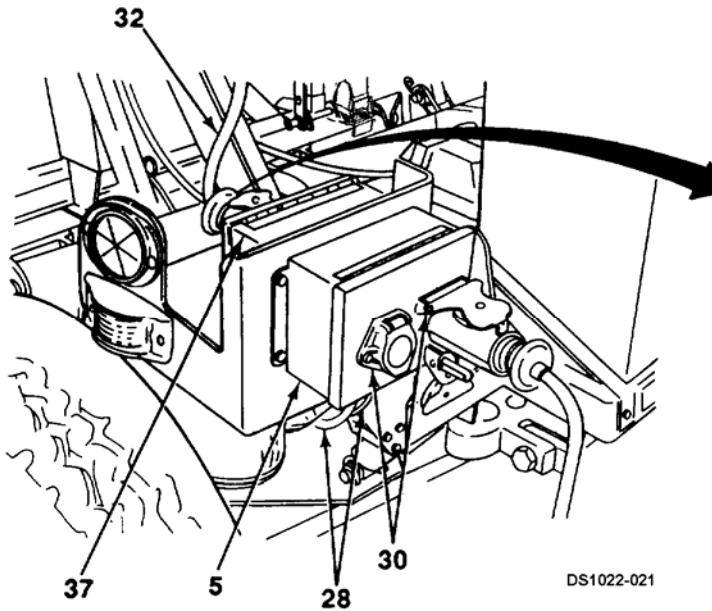
Item No.	Interval	Location	Procedure	Not Fully Mission Capable If:
		Item to Check/Service		
18 (Cont)	Before	Rear Electrical Installation	b. Check intradolly cable (32) for cuts, breaks, damaged connector plug (31), or other damage.	b. Intradolly cable is damaged.
				
19	Before	RIGHT SIDE	a. Check tires for underinflation and condition.	a. Tire is missing, deflated or unserviceable.
		Tire and Wheel Assemblies		

Table 2-1. Operator/Crew Preventive Maintenance Check and Services (PMCS) (Cont).

Item No.	Interval	Location		Procedure	Not Fully Mission Capable If:
		Item to Check/Service			
20	Before	Transportation Lockouts		Check condition of transportation lockouts (24).	Transportation lockouts are missing or damaged.
<p style="text-align: right; font-size: small;">DS1022-020</p>					
20.1	Before	Lift Cylinders		If lift cylinder rods (20.1) are dusty or dirty, wipe clean with a rag lightly oiled with lubricating oil (Item 23, Appendix F).	
21	Before	Ladder and Telescopic Braces		Check for condition and secure stowage of ladder (35) and telescopic braces (34) on bottom beam (25).	Telescopic brace is missing or damaged.
22	Before	Twist Locks and Stability Cables		Check that twist locks (23) and stability cables (24.1) at top beam (21) and twist locks (23) at bottom beam (25) are present and secure.	Twist lock and/or stability cable is missing, damaged, or not properly secured.

Table 2-1. Operator/Crew Preventive Maintenance Check and Services (PMCS) (Cont).

Item No.	Interval	Location	Procedure	Not Fully Mission Capable If:
		Item to Check/Service		
23	Before	Toolbox	Check contents of toolbox (33) against Basic Issue Items (BII) and Components of End Item (COEI) Lists (see Appendix D).	Toolbox, BII, or COEI missing.
24	Before	Front Electrical Installation	<p>a. Check signal conditioning box (5) and forward junction box (37) for damage to box, receptacle connectors (30), and cable assemblies (28).</p> <p>b. Check intradolly cable (32) for cuts, breaks, damaged connector plug (31), pins (36), or other damage.</p>	<p>a. Signal conditioning box, forward junction box, receptacle connectors, or cable assemblies are damaged.</p> <p>b. Intradolly cable is damaged.</p>



DS1022-021

Table 2-1. Operator/Crew Preventive Maintenance Check and Services (PMCS) (Cont).

Item No.	Interval	Location	Procedure	Not Fully Mission Capable If:
		Item to Check/Service		
25	Before	OVERALL DOLLY SET	<p><b>NOTE</b></p> <p>The following Before operation checks and services are performed with dolly set coupled to towing vehicle and airbrake system fully pressurized (see paragraph 2-11).</p> <p>a. Check air bags (42) for condition and inflation.</p> <p>b. Check shock absorbers (43) for damage.</p>	<p>a. Air bag is damaged or deflated.</p> <p>b. Shock absorber is damaged.</p>

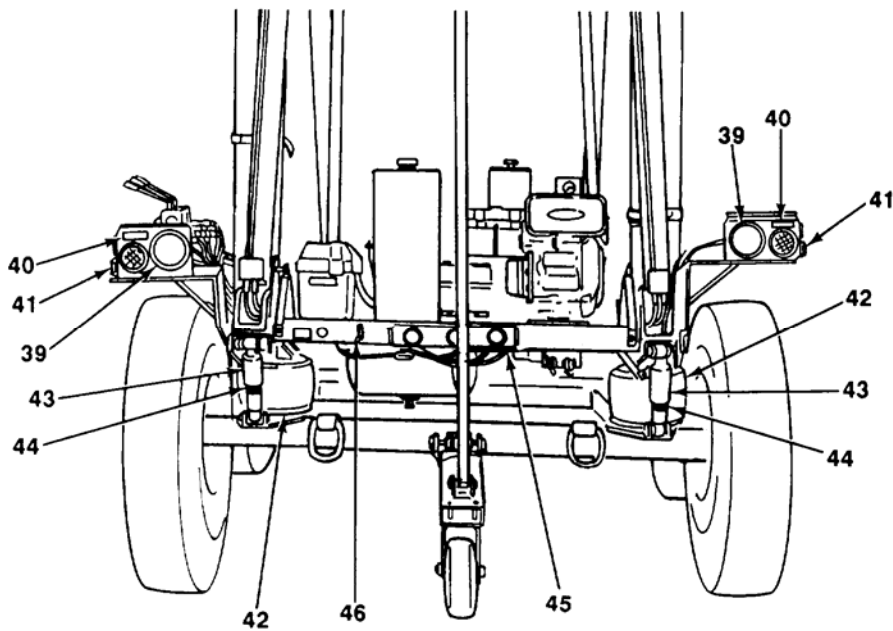


Table 2-1. Operator/Crew Preventive Maintenance Checks and Services (PMCS) (Con't).

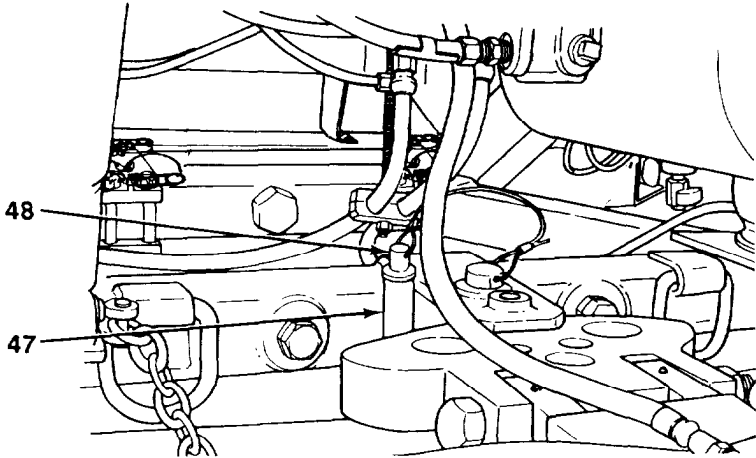
Item No.	Interval	Location	Procedure	Not Fully Mission Capable If:
		Item To Check/Service		
26	Before	Steering	<p>If towing dolly set, ensure that steering has been unlocked. Check that steering locking pin (48) has been removed from front axle and steering link and placed in stowed position in stowage tube (47).</p> 	
27	Before	Brakes	<p>a. Check to ensure that rear dolly parking brakes are released. Parking brake lever (46) must be set to OFF position.</p> <p>b. Apply service brakes and listen for sounds of air leaks.</p> <p>c. Pull towing vehicle slightly forward and check operation of dolly set service brakes.</p> <p style="text-align: center;">NOTE</p> <p>Front dolly has only marker clearance lights.</p>	<p>a. Parking brakes will not release.</p> <p>b. Air leaks are found.</p> <p>c. Service brakes do not operate properly.</p>
28	Before	Lights	<p>Check for proper operation of marker clearance lights (41), blackout stop-light-taillights (40) (if coupled to a 24-volt towing vehicle), taillights (39) and identification light (45). Ensure that lights turn on, and turn signals and brake lights operate.</p>	<p>Lights do not operate.</p>

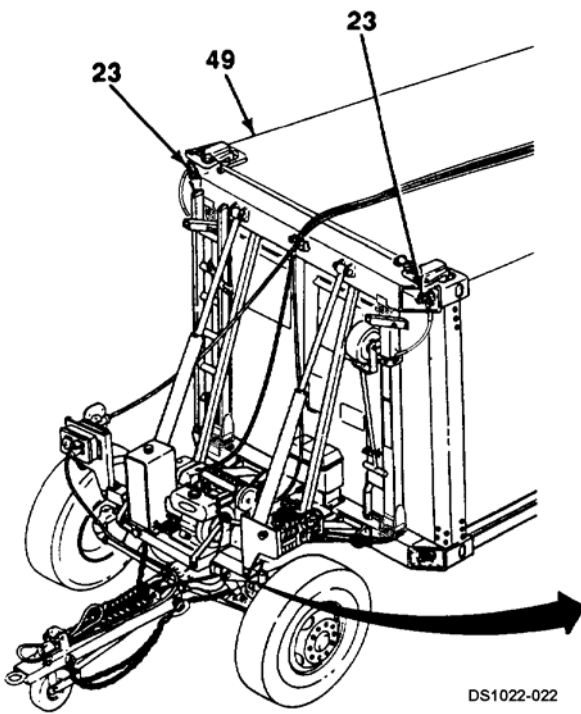
Table 2-1. Operator/Crew Preventive Maintenance Checks and Services (PMCS) (Con't).

tern No.	Interval	Location Item To Check/ Service	Procedure	Not Fully Mission Capable If:
29	During	OVERALL DOLLY SET	a. Check engine for proper starting (see paragraph 2-20).  b. Check levers (26) at hydraulic control valve (38) for smooth operation of lift and positioning cylinders. Be alert for signs of leaks.	a. Engine does not start.  b. Cylinders do not operate properly. Class III hydraulic fluid leakage is evident.
		Hydraulic System		

The diagram is a technical line drawing of a vehicle chassis, viewed from the rear. It shows two large rear wheels, a central steering wheel, and various mechanical components. Two callout numbers are present: '26' with an arrow pointing to a lever on the left side of the chassis, and '38' with an arrow pointing to a control valve located in the center of the chassis, above the steering wheel. The drawing is detailed, showing hoses, pipes, and structural elements of the chassis.

Table 2-1. Operator/Crew Preventive Maintenance Check and Services (PMCS) (Cont).

Item No.	Interval	Location	Procedure	Not Fully Mission Capable If:
		Item to Check/Service		
30	During	Shelter	<p>a. Check shelter (49) for security. Check all twist locks (23) for tightness.</p> <p>b. Check to ensure that shelter (49) is riding level. Check air bags (42) for even inflation by visually checking ride height indicator rings (44) on shock absorbers (43). As required, use charging assembly (Item 1, Appendix D) to add air (see paragraph 2-22).</p>	



DS1022-022

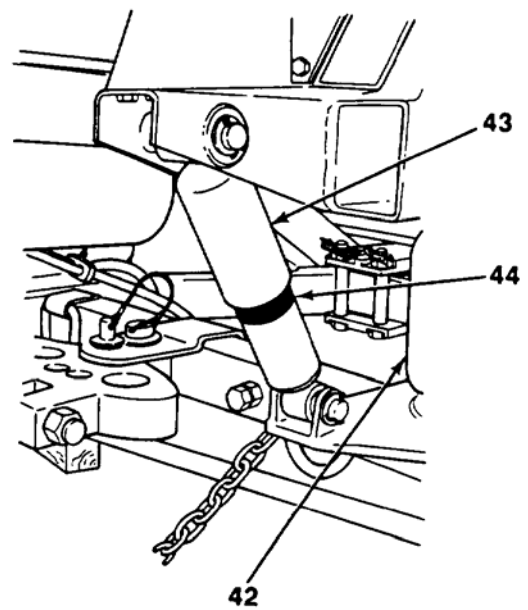




Table 2-1. Operator/Crew Preventive Maintenance Check and Services (PMCS) (Cont).

Item No.	Interval	Location	Procedure	Not Fully Mission Capable If:
		Item to Check/Service		
31	During	Brakes	<p>a. Check brakes for any unusual conditions (grabbing, pulling, or slow operation).</p> <div style="border: 1px solid black; padding: 5px; text-align: center; width: fit-content; margin: 10px auto;"> <b>WARNING</b> </div> <p><b>Cautiously feel each wheel hub and brakedrum. Wheel hubs and brakedrums may be hot. Failure to follow this warning may result in serious burns to personnel.</b></p> <p>b. When stopped, cautiously feel each wheel hub and brakedrum. Check for a wheel hub and brakedrum that is hotter or cooler than the others. Overheating could indicate improperly adjusted or defective wheel bearings, or a lock-up brake. A cool wheel hub and brakedrum could indicate an inoperative brake.</p>	
32	During	Tracking	Check dolly set for wandering or pulling to one side and for any unusual vibration or noises.	
32.1	During	Rear Service Light	<p style="text-align: center;"><b>NOTE</b></p> <p><b>Rear dolly has intermittent illuminating service light.</b></p> <p>a. Check for loose bulb. If bulb is tight but lamp lights intermittently when bracket is moved back and forth, the problem is a possible loose pin in the MS connector.</p> <p>b. Continue mission and repair when mission is completed.</p>	
		<b>FRONT</b>		
33	After	Overall View	<p>a. Check under front dolly for evidence of fluid leakage.</p> <p>b. Check for obvious damage to front dolly that would impair operation.</p>	<p>a. Class III hydraulic fluid or oil leakage is evident. Class III fuel leakage is evident.</p> <p>b. Front dolly damage impairs operation.</p>

Table 2-1. Operator/Crew Preventive Maintenance Checks and Services (PMCS) (Con't).

Item No.	Interval	Location Item To Check/ Service	Procedure	Not Fully Mission Capable If:
34	After	Pivoting Tray Airbrake Components	<p>a. Open air reservoir draincock (20), and allow air and moisture to drain. Close draincock.</p> <p>b. Check air lines (50) for cracks, breaks, and kinks. Ensure that air lines are securely supported. Check valves (51) and fittings for damage.</p>	<p>b. Air lines, valves, or fittings are damaged.</p>

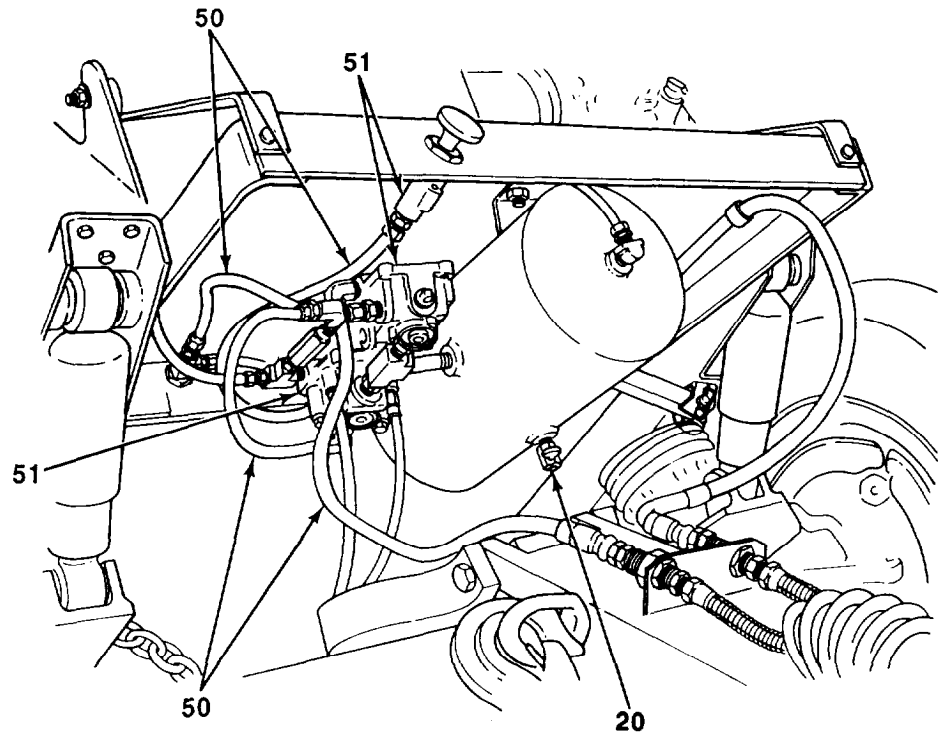


Table 2-1 . Operator/Crew Preventive Maintenance Checks and Services (PMCS) (Con't).

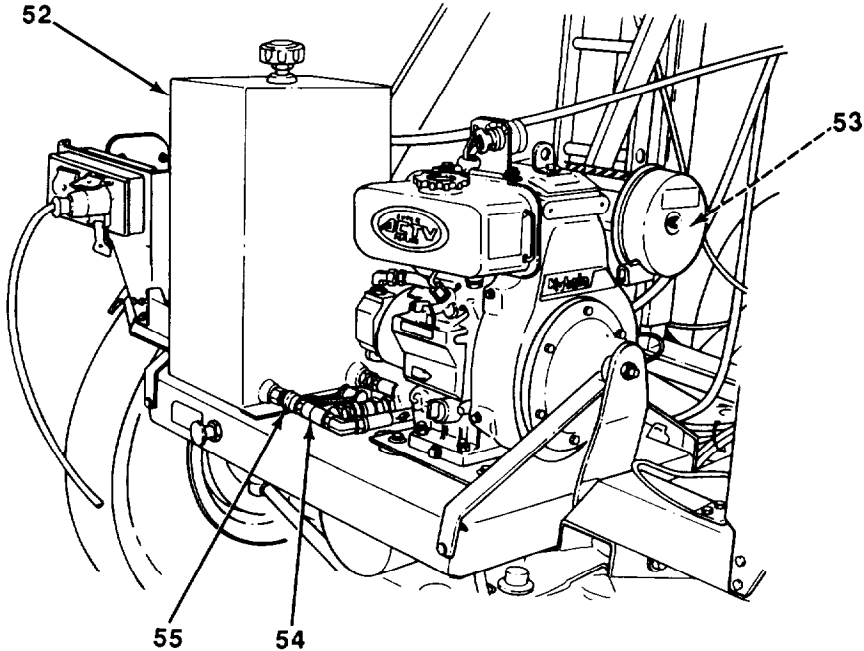

Item No.	interval	Location	Procedure	Not Fully Mission Capable If:
		Item To Check/Service		
35	After	Hydraulic Reservoir and Redundant Power Quick Disconnects	Check hydraulic reservoir (52) and redundant power quick disconnects (55) at pivoting tray for damage and leaks. Ensure that lockwire (54) for redundant power quick disconnects is present and secure.	Damage is found. Class III hydraulic fluid leakage is evident.
				
36	After	Engine Air Cleaner	<div style="display: flex; align-items: center; justify-content: center;">  <div style="border: 1px solid black; padding: 2px 10px; font-weight: bold;">WARNING</div> </div> <p>If NBC exposure is suspected, all engine air cleaner air filter media should be handled by personnel wearing protective equipment. Consult your NBC Officer or NBC NCO for appropriate handling or disposal procedures.</p> <p>If operating in sandy or dusty areas, clean engine air cleaner element (53) (see paragraph 3-10).</p>	

Table 2-1. Operator/Crew Preventive Maintenance Checks and Services (PMCS) (Con't).

Item No.	interval	Location	Procedure	Not Fully Mission Capable If:
		Item To Check/Service		
37	After	Suspension	a. Check air bags (42) for cuts, cracks, and general condition.  b. Check shock absorbers (43) for damage.	a. Air bag is ruptured or damaged.  b. Shock absorber is damaged.
<p>The diagram shows a side view of a vehicle's front suspension assembly. Callout 42 points to a large, cylindrical air bag component. Callout 43 points to the shock absorber assembly, which includes a coil spring and a shock absorber body. The drawing shows various mechanical linkages, bolts, and hoses connected to the suspension components.</p>				

Table 2-1. Operator/Crew Preventive Maintenance Checks and Services (PMCS) (Con't).

Item No.	Interval	Location	Procedure	Not Fully Mission Capable If:
		Item To Check/Service		
38	After	LEFT SIDE	a. Check hydraulic control valve (38) and levers (26) at front dolly for damage and security of mounting. b. Check hydraulic lines (56) and fittings at front dolly for cracks, breaks, kinks, and leaks. Ensure that hydraulic lines are securely mounted, protectively wrapped, and supported.	a. Hydraulic control valve or levers are damaged. b. Hydraulic lines or fittings are damaged. Class III hydraulic fluid leakage is evident.
		Hydraulic Control Valve and Lines		

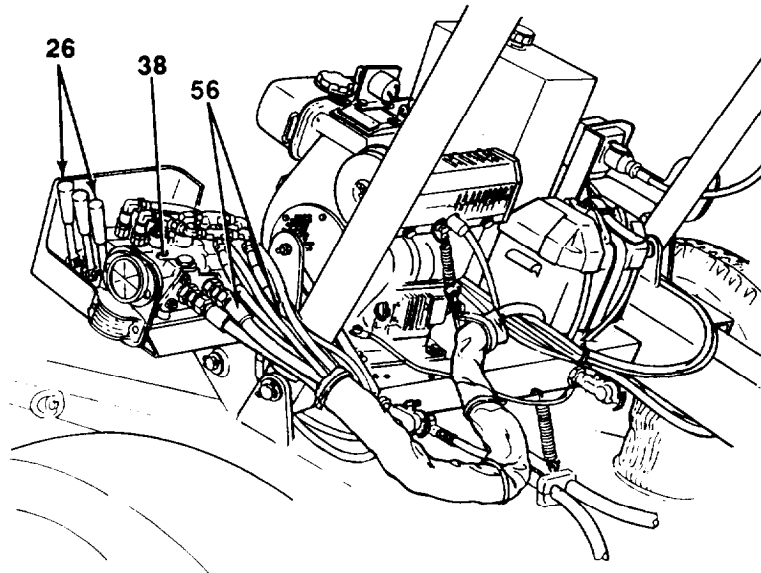


Table 2-1. Operator/Crew Preventive Maintenance Check and Services (PMCS) (Cont).

Item No.	Interval	Location	Procedure	Not Fully Mission Capable If:
		Item to Check/Service		
38.1	After	Lift Cylinders	a. Wipe clean machined surface of lift cylinder rods (56.1) using a clean rag (Item 25, Appendix F).  b. Inspect rods (56.1) for signs of pitting, corrosion or other damage. Pay particular attention to cylinder heads (56.3). Ensure that rod wipers (56.2) are not damaged or dislodged from cylinder heads.	b. Rod is damaged or rod wiper is damaged or dislodged.

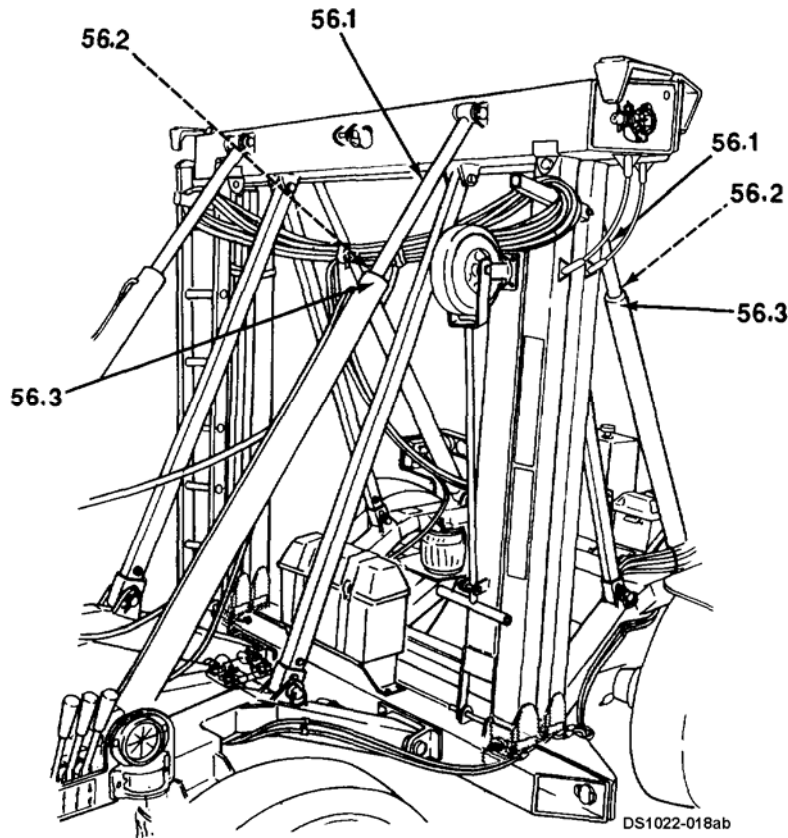




Table 2-1. Operator/Crew Preventive Maintenance Checks and Services (PMCS) (Can't).

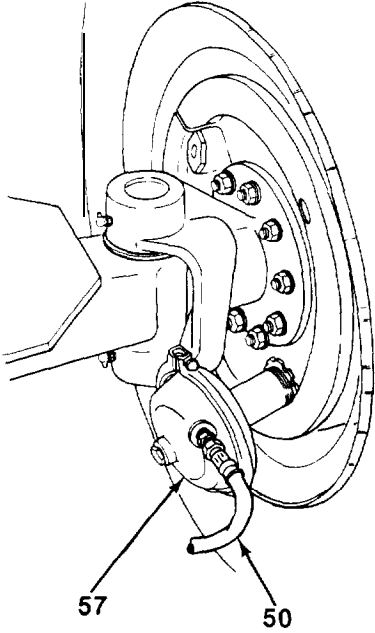
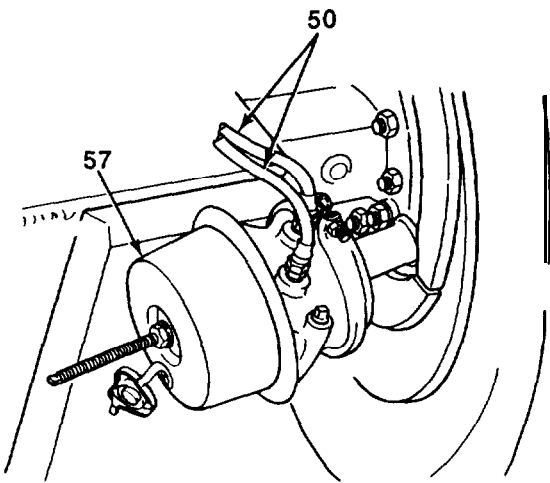
Item No.	Interval	Location	Procedure	Not Fully Mission Capable If:
		Item To Check/Service		
39	After	Front Airbrake Chamber	<p>Check for damage to airbrake chamber (57) and air line (50) at wheel.</p> 	Airbrake chamber or air line is damaged.
40	After	Rear Airbrake Chamber	<p>Check for damage to airbrake chamber (57) and air lines (50) at wheel.</p> 	Airbrake chamber or air lines are damaged.



Table 2-1. Operator/Crew Preventive Maintenance Checks and Services (PMCS) (Con't).

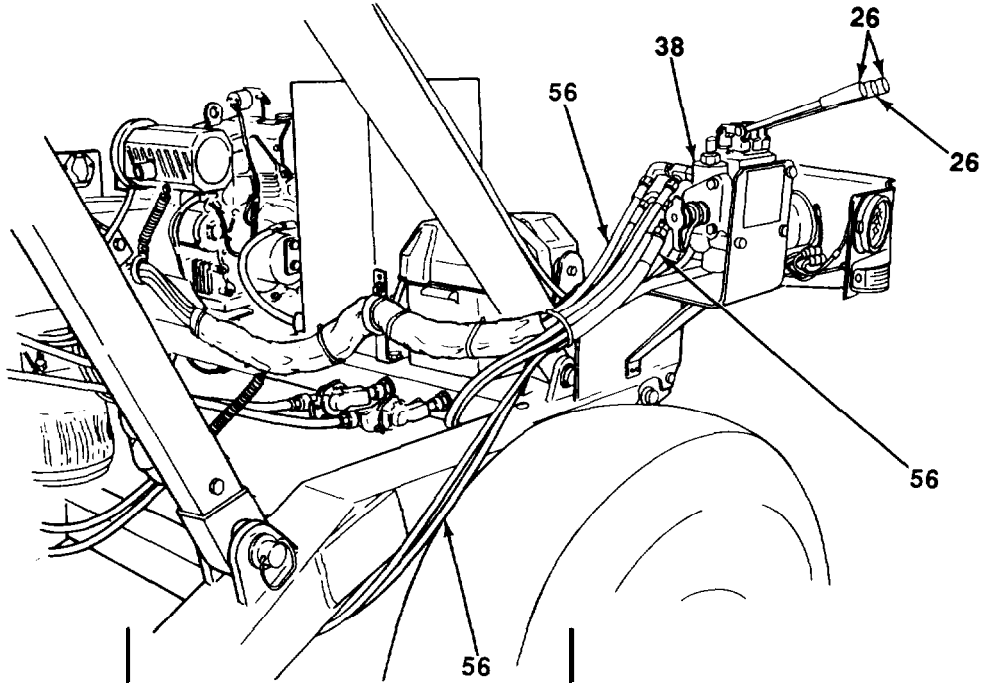
Item No.	Interval	Location	Procedure	Not Fully Mission Capable If:
		Item To Check/Service		
41	After	Hydraulic Control Valve and Lines	a. Check hydraulic control valve (38) and levers (26) at rear dolly for damage and security of mounting. b. Check hydraulic lines (56) and fittings at rear dolly for cracks, breaks, kinks, and leaks. Ensure that hydraulic lines are securely mounted, protectively wrapped, and supported.	a. Hydraulic control valve or levers are damaged.  Hydraulic lines or fittings are damaged. Class III hydraulic fluid leakage is evident.
				
42	After	REAR	a. Check under rear dolly for evidence of fluid leakage.  b. Check for obvious damage to rear dolly that would impair operation.	a. Class III hydraulic fluid or oil leakage is evident. Class II fuel leakage is evident.  b. Rear dolly damage impairs operation.
		Overall View		
43	After	Pivoting Tray Airbrake Components	a. Open air reservoir draincock (20), and allow air and moisture to drain. Close draincock.	

Table 2-1. Operator/Crew Preventive Maintenance Checks and Services (PMCS) (Con?).

Item No.	interval	Location	Procedure	Not Fully Mission Capable If:
		Item To Check/Service		
43 (Con't)	After	Pivoting Tray Airbrake Components	<p>b. Check air lines (50) for cracks, breaks, and kinks. Ensure that air lines are securely supported. Check valves (51) and fittings for damage.</p> <p>c. Check to ensure that parking brake lever (46) is set to ON position.</p>	b. Air lines, valves, or fittings are damaged.

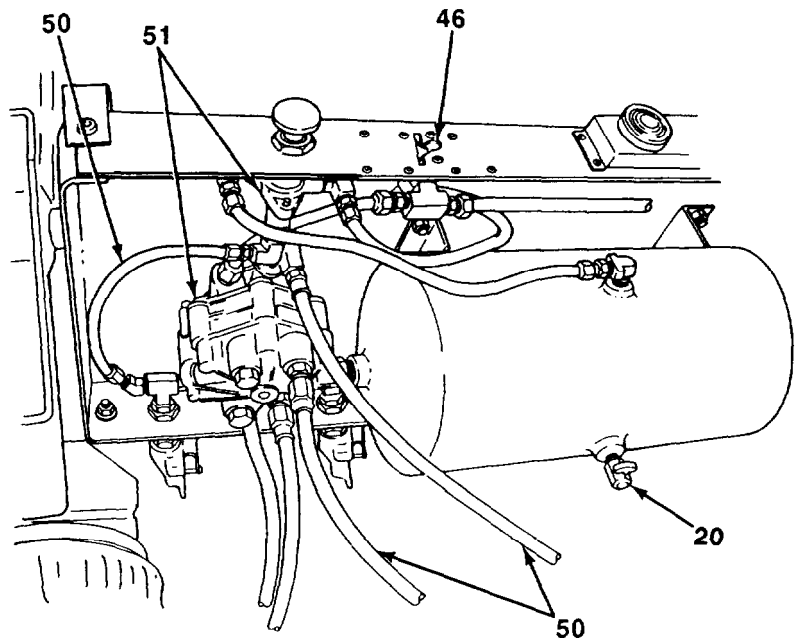


Table 2-1. Operator/Crew Preventive Maintenance Checks and Services (PMCS) (Con?).

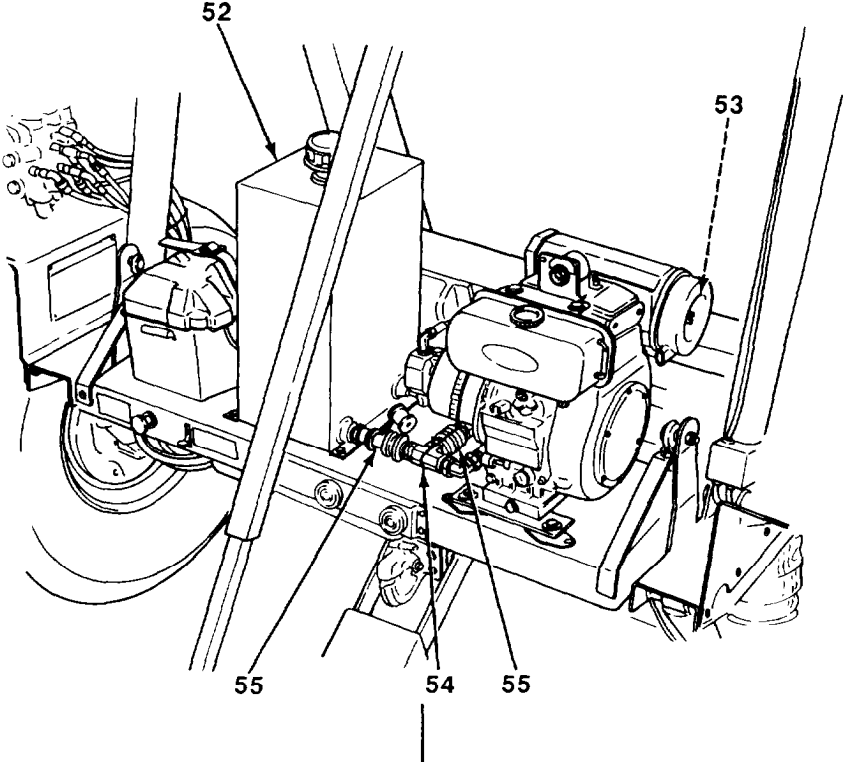


Item No.	Interval	Location	Procedure	Not Fully Mission Capable If:
		Item To Check/ Part		
44	After	Hydraulic Reservoir and Redundant Power Quick Disconnects	<p>Check hydraulic reservoir (52) and redundant power quick disconnects (55) at pivoting tray for damage and leaks. Ensure that lockwire (54) for redundant power quick disconnects is present and secure.</p> 	Damage is found. Class III hydraulic fluid leakage is evident.
45	After	Engine Air Cleaner	  <p>If NBC exposure is suspected, all engine air cleaner air filter media should be handled by personnel wearing protective equipment. Consult your NBC Officer or NBC NCO for appropriate handling or disposal procedures.</p> <p>If operating in sandy or dusty areas, clean air cleaner element (53) (see paragraph 3-10).</p>	

Table 2-1. Operator/Crew Preventive Maintenance Checks and Services (PMCS) (Con?).

Item No.	Interval	Location Item To Check/ Service	Procedure	Not Fully Mission Capable If:
46	After	Suspension	<p>a. Check air bags (42) for cuts, a. cracks, and general condition.</p> <p>b. Check shock absorbers (43) for b. damage.</p>	<p>a. Air bag is ruptured or damaged.</p> <p>b. Shock absorber is damaged.</p>

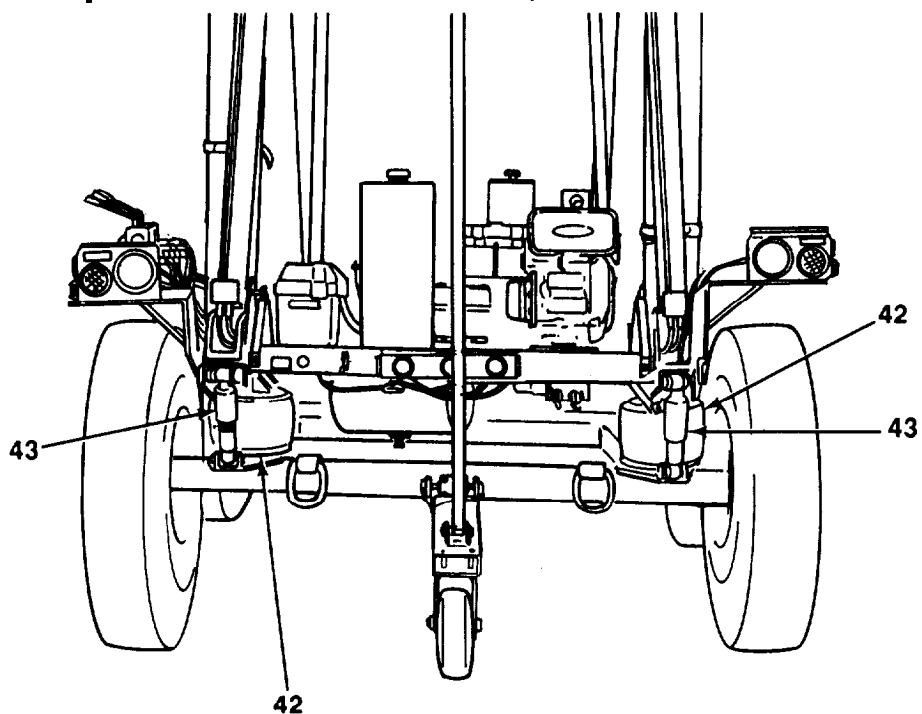


Table 2-1. Operator/Crew Preventive Maintenance Checks and Services (PMCS) (Con't).

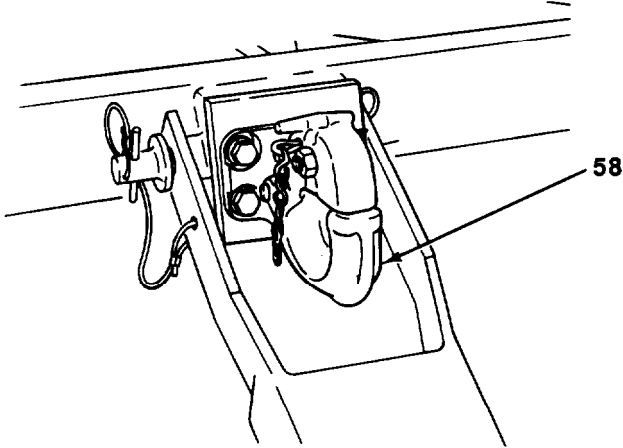
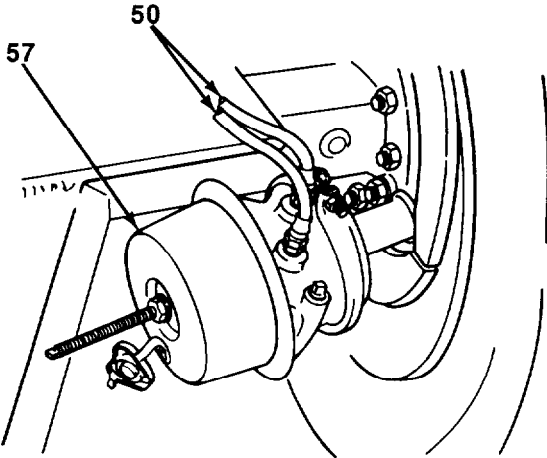
Item No.	Interval	Location	Procedure	Not Fully Mission Capable It:
		Item To Check/Service		
47	After	Pintle Assembly	Check for damage to pintle assembly (58).	
48	After	RIGHT SIDE	Check for damage to air-brake chamber (57) and air lines (50) at wheel.	Airbrake chamber or air lines are damaged.
		Rear Airbrake Chamber		
				
				

Table 2-1. Operator/Crew Preventive Maintenance Check and Services (PMCS) (Cont).

Item No.	Interval	Location	Procedure	Not Fully Mission Capable If:
		Item to Check/Service		
49.1	After	Lift Cylinders	<p>a. Wipe clean machine surface of lift cylinder rods (56.1) using a clean rag (Item 25, Appendix F).</p> <p>b. Inspect rods (56.1) for signs of pitting, corrosion or other damage. Pay particular attention to cylinder heads (56.3). Ensure that rod wipers (56.2) are not damaged or dislodged from cylinder heads.</p>	<p>b. Rod is damaged or rod wiper is damaged or dislodged.</p>

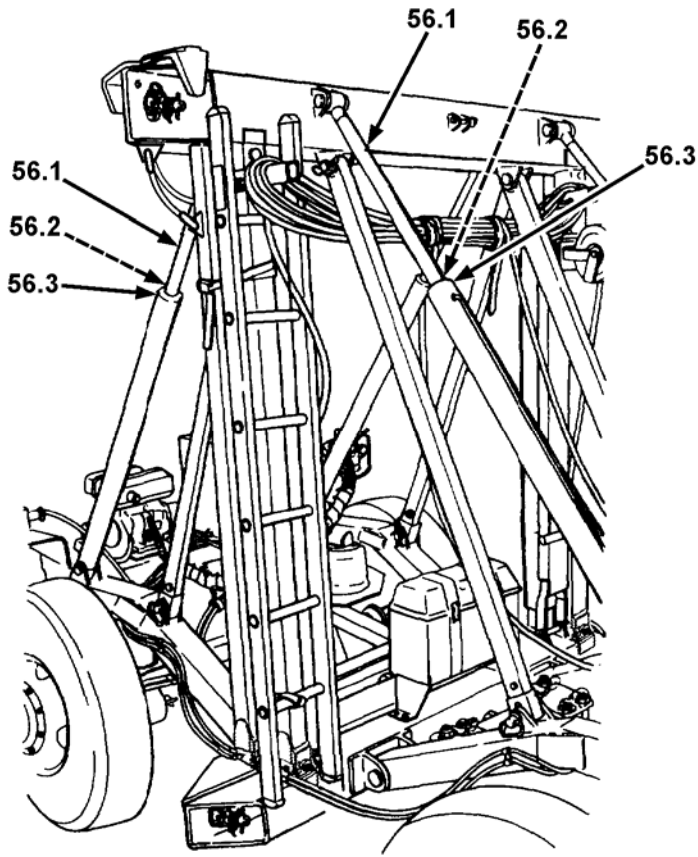


Table 2-1. Operator/Crew Preventive Maintenance Checks and Services (PMCS) (Con't).

Item No.	Interval	Location	Procedure	Not Fully Mission Capable If:
		Item To Check/Service		
50	Weekly	OVERALL DOLLY SET	<p><b>NOTE</b></p> <p>Unless otherwise indicated, the following checks must be performed on BOTH front and rear dollies.</p> <p>Lower dolly set to ground (see paragraph 2-8). Remove cap (59) from hydraulic reservoir (52). Check level of hydraulic fluid (see paragraph 3-7). Add hydraulic fluid as required (see Lubrication Instructions, Chapter 3, Section I).</p>	
		Hydraulic Reservoir		

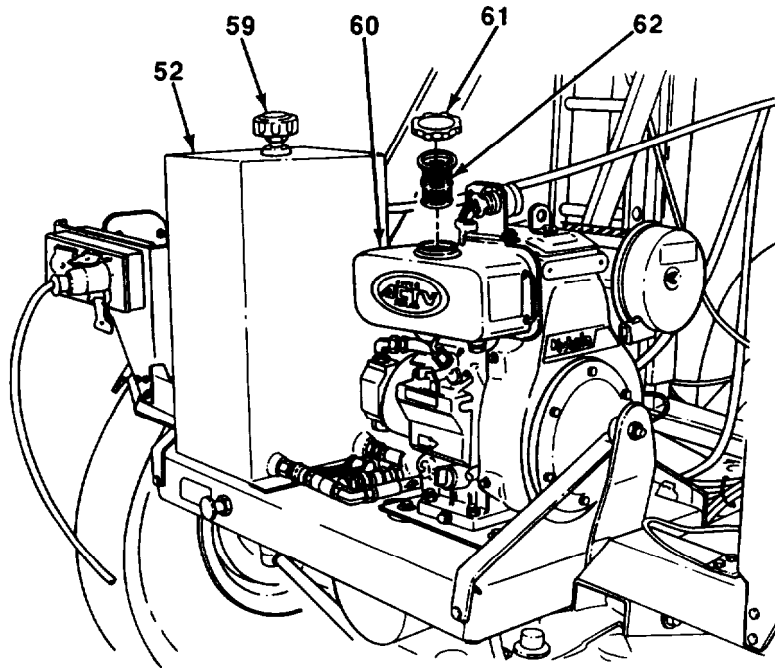






Table 2-1. Operator/Crew Preventive Maintenance Checks and Services (PMCS) (Con't).



Item No.	Interval	Location	Procedure	Not Fully Mission Capable It:
		Item To Check/Service		
51	Weekly	Engine Fuel Tank Strainer	  <p>Diesel fuel is combustible. DO NOT smoke or allow open flame near fuel tank. Shut down engine when adding fuel. Failure to follow this warning will result in serious injury or death to personnel. If you are burned, immediately seek medical attention.</p> <p>Remove cap (61) from fuel tank (60). Clean obstructions and remove contaminants from strainer (62) as required (see paragraph 3-9).</p>	
52	Weekly	Crankcase Oil and Filter	<p>If engine is new, notify Unit Maintenance after initial week of operation to drain crankcase oil and clean oil filter. Fill crankcase with proper grade of oil (see Lubrication Instructions, Chapter 3, Section I).</p>	

Table 2-1. Operator/Crew Preventive Maintenance Checks and Services (PMCS) (Con't).



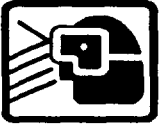
Item No.	Interval	Location	Procedure	Not Fully Mission Capable If:
		Item To Check/Service		
53	Weekly	Batteries	<div style="display: flex; justify-content: space-around; align-items: center;">   <div style="border: 1px solid black; padding: 2px; text-align: center;"><b>WARNING</b></div>  </div> <ul style="list-style-type: none"> <li>· Remove all jewelry such as I.D. tags, rings, bracelets, etc. If jewelry contacts battery terminal, a direct short will result causing instant heating of jewelry which will result in serious injury or death to personnel.</li> <li>· Battery acid (electrolyte) is extremely dangerous. Always wear protective goggles and rubber gloves when performing battery checks or inspections. Serious injury to personnel will result if battery acid contacts skin or eyes.</li> <li>· DO NOT perform battery system checks or inspections while smoking or near fire, flames, or sparks. Battery gases may explode, causing serious injury or death to personnel.</li> </ul> <p>a. Unfasten strap (14) and remove cover (15) from battery case (19). inspect battery (16) for a cracked or damaged case.</p> <div style="text-align: center; margin: 10px 0;"> <div style="border: 1px solid black; padding: 2px; display: inline-block;"><b>CAUTION</b></div> </div> <p>Avoid overtightening strap, which may damage strap or buckle.</p>	<p>a. Battery case is damaged or missing.</p>

Table 2-1. Operator/Crew Preventive Maintenance Check and Services (PMCS) (Cont).

Item No.	Interval	Location	Procedure	Not Fully Mission Capable If:
		Item to Check/Service		
53 (Cont)	Weekly	Batteries	<p>b. Inspect battery (16) for burned, corroded, or dirty terminals (27). Inspect battery cables (18) for dirt, corrosion, or loose connections. Clean battery terminals and cable end connections as required (see TM 9-6140-200-14). Install cover (15) and fasten strap (14).</p>	<p>b. Terminals or cables are damaged or missing.</p>
54	Weekly	Tire and Wheel Assemblies	<p>a. Check wheels for breaks or bends.</p> <p>b. Check dolly set tires for proper inflation of 100 psi (758 kPa) for use on highway, cross-country, muds, sand, or air transport.</p> <p>c. Check caster wheel assembly tires for inflation of 95 psi (655 kPa).</p>	<p>a. Wheels are damaged.</p>

Table 2-1. Operator/Crew Preventive Maintenance Check and Services (PMCS) (Cont).

Item No.	Interval	Location	Procedure	Not Fully Mission Capable If:
		Item to Check/Service		
55	Weekly	Frame and Suspension Assembly	<p>a. Inspect top beams (21), bottom beams (25), suspension links (65), pivot axle bracket (63), and axle (64) for cracks, breaks, or bends.</p> <p>b. Check security of mounting of pivoting tray (66).</p>	<p>a. Frame is damaged.</p> <p>b. Pivoting tray mounting is not secure.</p>

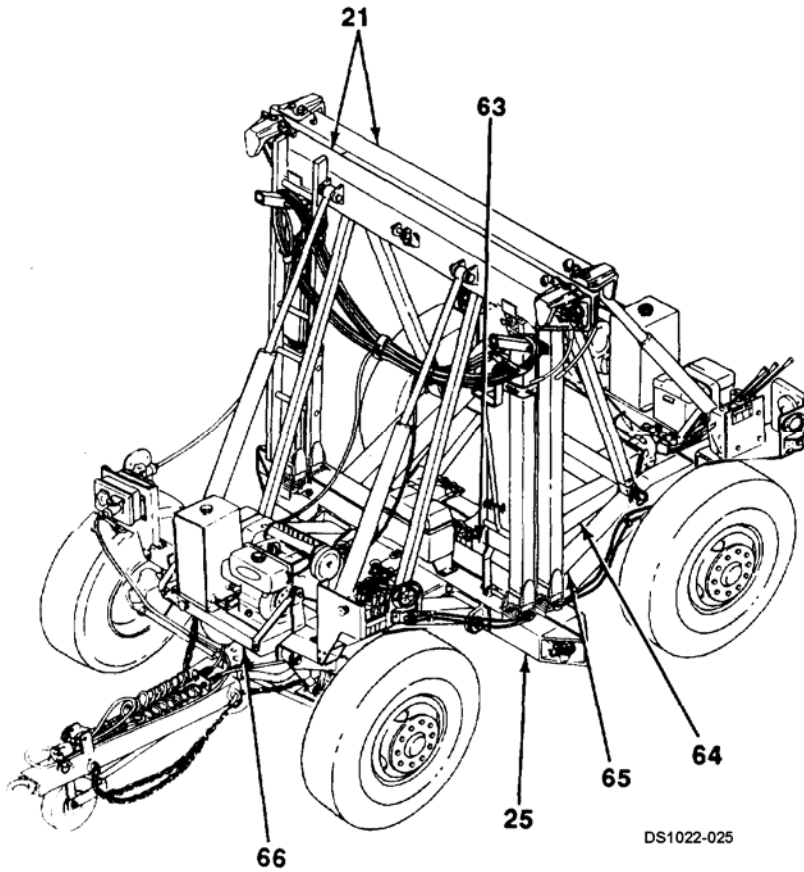
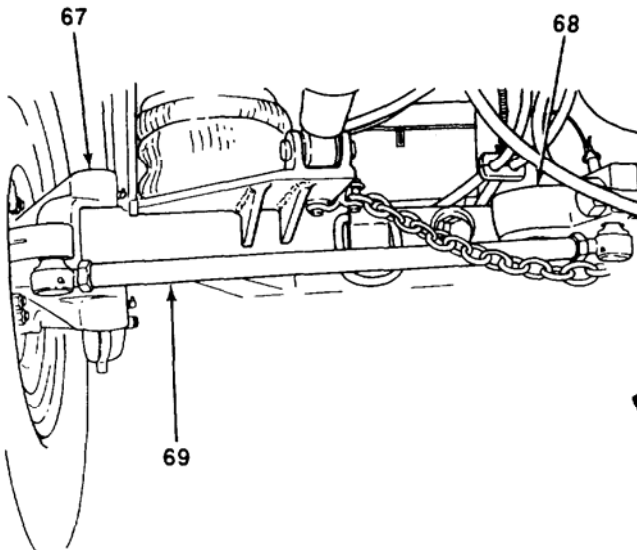
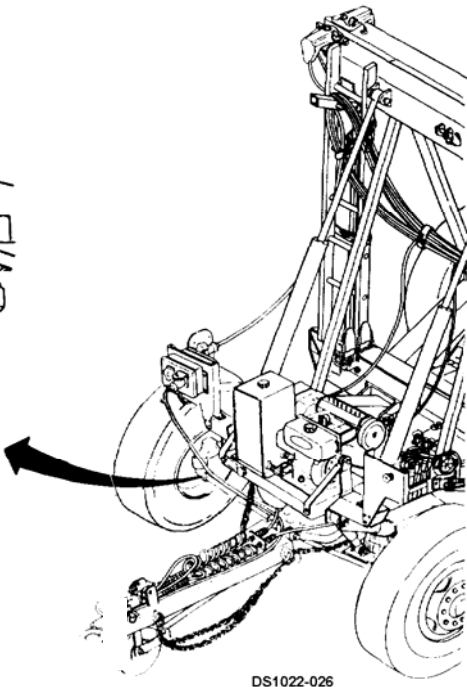


Table 2-1. Operator/Crew Preventive Maintenance Check and Services (PMCS) (Cont).

Item No.	Interval	Location	Procedure	Not Fully Mission Capable If:
		Item to Check/Service		
56	Weekly	Front Axle Steering Components	Inspect steering knuckle assemblies (67), steering link (68), and tie-rods (69) for cracks, breaks, bends, and loose mounting.	Steering knuckle assembly, steering link, or tie-rod is damaged.

DS1022-026

**Section III. OPERATIONS UNDER USUAL CONDITIONS**

<b>Paragraph Number</b>	<b>Paragraph Title</b>	<b>Page Number</b>
2.6.	Introduction .....	2-44
2-7.	Uncoupling Dolly Set With or Without Shelter from Towing Vehicle .....	2-45
2-8.	Lowering Dolly Set With or Without Shelter and Detaching Front and Rear Dollies .....	2-52
2-9.	Attaching Front and Rear Dollies to Shelter .....	2-59
2-10.	Attaching Front and Rear Dollies to Each Other .....	2-67
2-11.	Raising Dolly Set With or Without Shelter and Coupling to Towing Vehicle .....	2-76
2-12.	Attaching Front and Rear Dollies to Shelter (Shelter On Ground) (Side Lift Operation) .....	2-84
2-13.	Attaching Front and Rear Dollies to Shelter (Shelter On Trailer) (Side Lift Operation) .....	2-92
2-14.	Raising Dolly Set With Shelter and Loading Onto Trailer (Side Lift Operation) ...	2-100
2-15.	Detaching Front and Rear Dollies from Shelter (Shelter On Trailer) (Side Lift Operation) .....	2-103
2-16.	Detaching Front and Rear Dollies from Shelter (Shelter On Ground) (Side Lift Operation) .....	2-100
2-17.	Lowering Dolly Set With Shelter from Trailer (Side Lift Operatlon) .....	2-117
2-18.	General Towing Instructions .....	2-120
2-19.	Tandem Towing .....	2-122
2-20.	Operating Engine .....	2-129
2-21.	Operating Hydraulic Control Valve .....	2-131
2-22.	Inflating Air Bags .....	2-139

**2-6. INTRODUCTION.**

**a. General.**

(1) This Section contains instructions for safely operating the M1022A1 Dolly Set under usual conditions. Unusual operating conditions are defined and described In Section IV of this chapter.

(2) Ensure that all Operator/Crew PMCS have been performed before operating the dolly set.

(3) Review towing vehicle operating instructions to prepare for coupling and uncoupling operations.

**b. Standard Operating Cycles.**

(1) The dolly set operating cycle consists of: uncoupling a dolly set without shelter from the towing vehicle; lowering the dolly set to the ground and detaching front and rear dollies from each other; attaching front and rear dollies to the shelter; and, raising the dolly set with shelter and coupling to the towing vehicle.

(2) When the dolly set with shelter has been towed to its destination, the operating cycle is repeated with minor differences to: uncouple the dolly set with shelter from the towing vehicle; lower the dolly set with shelter to the ground; detach front and rear dollies from the shelter; attach front and rear dollies to each other; and, raise and couple the dolly set without shelter to the towing vehicle.

(3) Paragraphs 2-7 through 2-11 describe standard operating cycles.

---

## 2-6. INTRODUCTION (Con't).

---

### c. Side Lift Operating Cycles.

- (1) With side lift kit installed, the dolly set can be attached using side lift mode to a shelter positioned either on the ground or on a trailer.
- (2) Once attached in side lift mode, the shelter can be either loaded onto or removed from a trailer.
- (3) Paragraphs 2-12 through 2-17 describe side lift operating cycles.

d. **Personnel Required.** All dolly set operations require two personnel minimum.

---

## 2-7. UNCOUPLING DOLLY SET WITH OR WITHOUT SHELTER FROM TOWING VEHICLE.

---

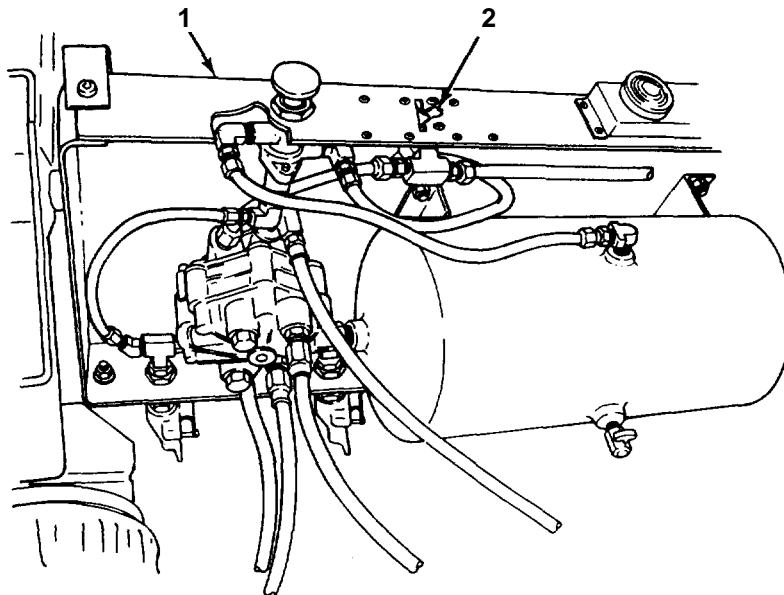
**WARNING**

All personnel must use caution when standing near dolly set, shelter (if present), and towing vehicle during uncoupling operation. Failure to follow this warning may cause serious injury or death to personnel.

### NOTE

Procedures to uncouple dolly set, with or without shelter, from towing vehicle are similar. Differences will be identified as they occur.

- a. Stop towing vehicle close to where dolly set or shelter is needed.
- b. At rear pivoting tray (1), turn parking brake lever (2) to ON position to apply rear dolly parking brakes.

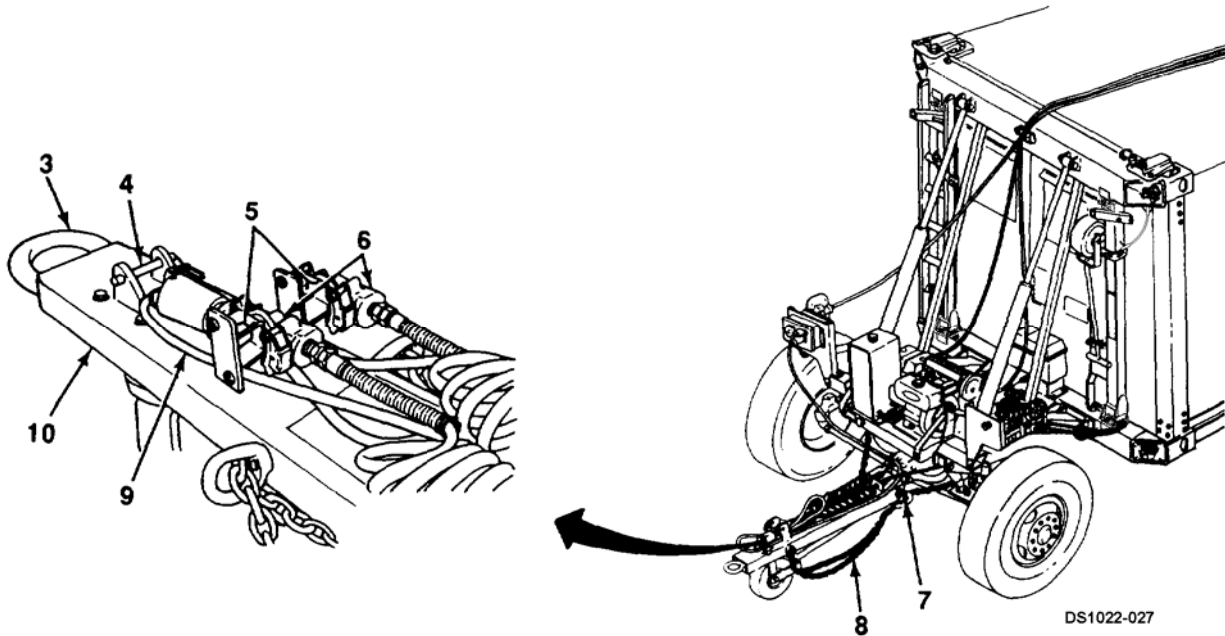


---

## 2-7. UNCOUPLING DOLLY SET WITH OR WITHOUT SHELTER FROM TOWING VEHICLE (Cont).

---

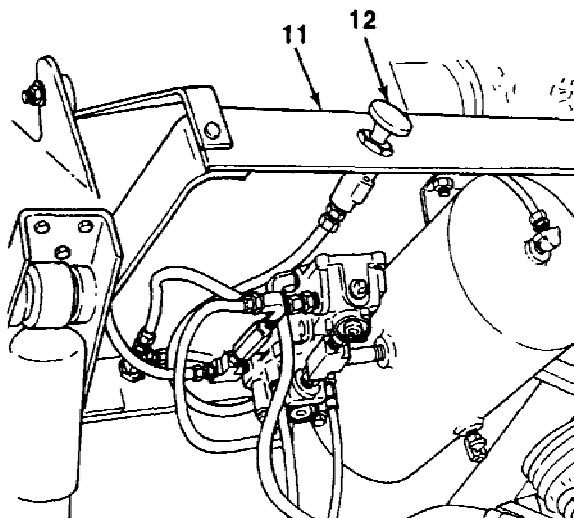
- c. Disconnect intervehicular cable (9) from rear of towing vehicle. Release intervehicular cable from under detent pin (4), gather up excess cable as required, and stow on top of front drawbar (10).
- d. Close air valves at rear of towing vehicle (see towing vehicle Operator's Manual).
- e. Disconnect two intervehicular air hose gladhands (6) from towing vehicle gladhands. Stow on dummy couplings (5).
- f. Remove safety chains (8) from towing vehicle. Stow safety chains on rearmost eyebolts (7).
- g. Remove safety pin, open towing vehicle pintle assembly, and lift off lunette (3). Pull towing vehicle forward. Close pintle assembly and install safety pin.



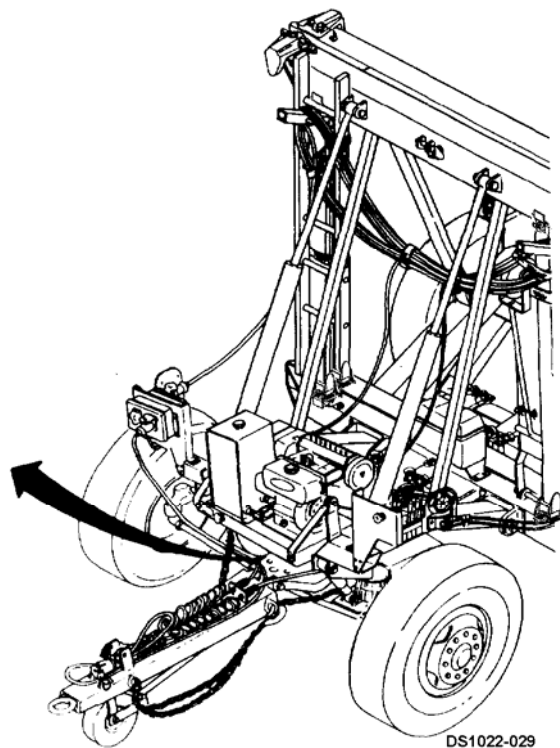
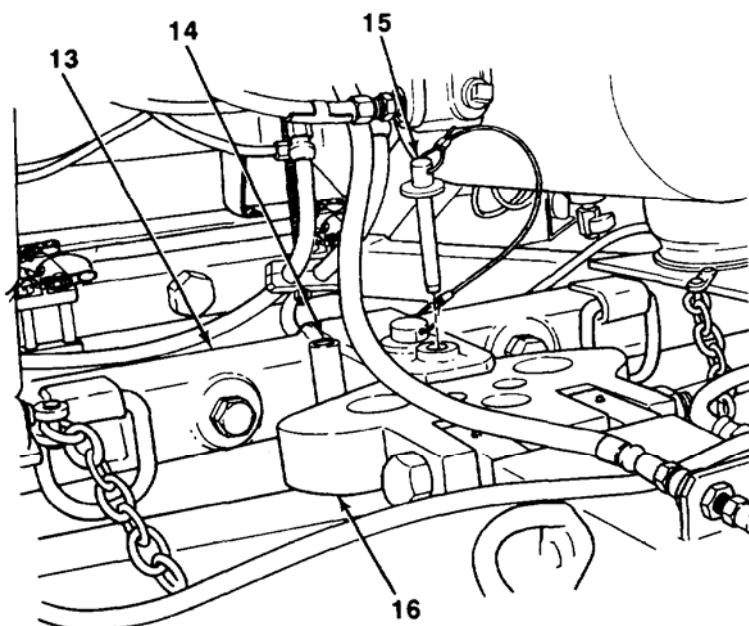


**2-7. UNCOUPLING DOLLY SET WITH OR WITHOUT SHELTER FROM TOWING VEHICLE (Cont).**

h. Release brakes on front dolly by pushing in on airbrake control knob (12) on pivoting tray (11).



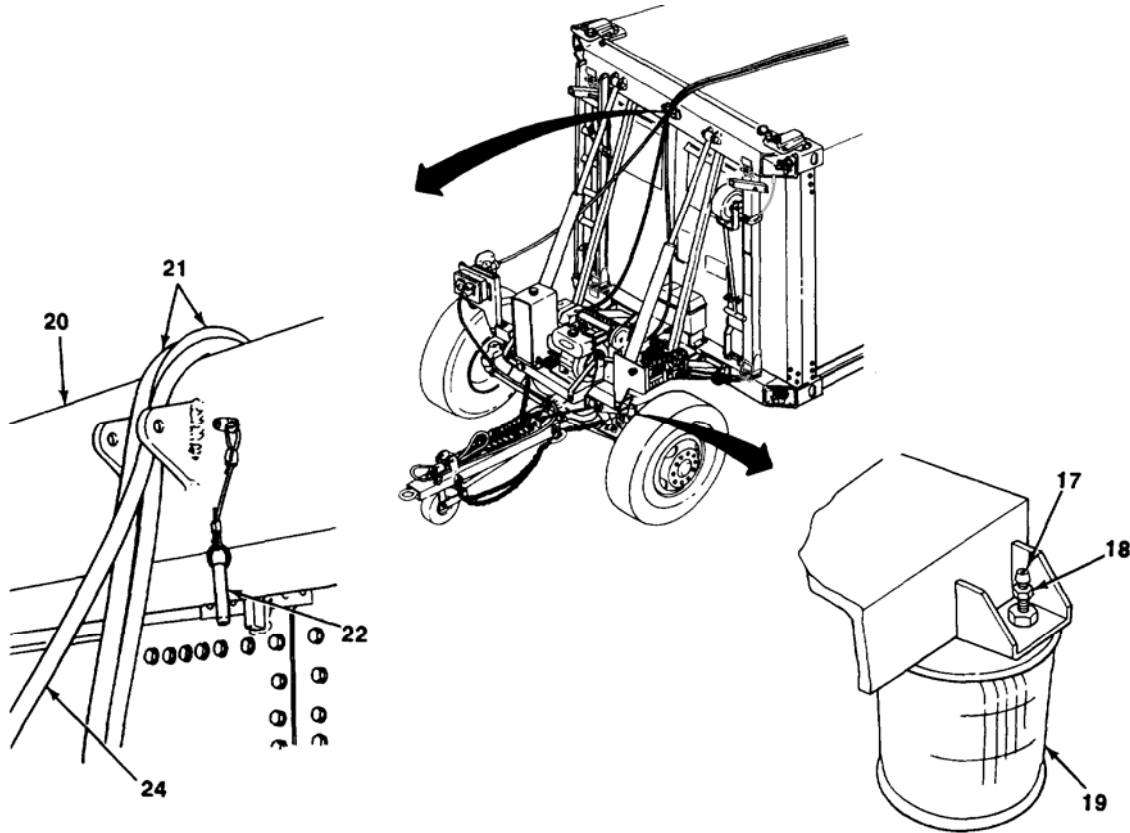
i. Remove steering locking pin (15) from stowage tube (14). Install steering locking pin through front axle (13) and steering link (16) to lock steering.



DS1022-029

**2-7. UNCOUPLING DOLLY SET WITH OR WITHOUT SHELTER FROM TOWING VEHICLE (Cont).**

j. At front and rear, remove two caps (17) of air bag valves (18) and deflate air bags (19). Install caps on air bag valves.



DS1022-030

**WARNING**

Use extreme caution when using ladder. Have an assistant hold ladder to ensure that it is stable. Failure to follow this warning may cause serious injury to personnel.

**NOTE**

If uncoupling dolly set with shelter, perform step k.

k. Release two intradolly air hoses (21) and intradolly cable (24) from under telescopic brace detent pin (22) at midpoint of front and rear dolly top beams (20).

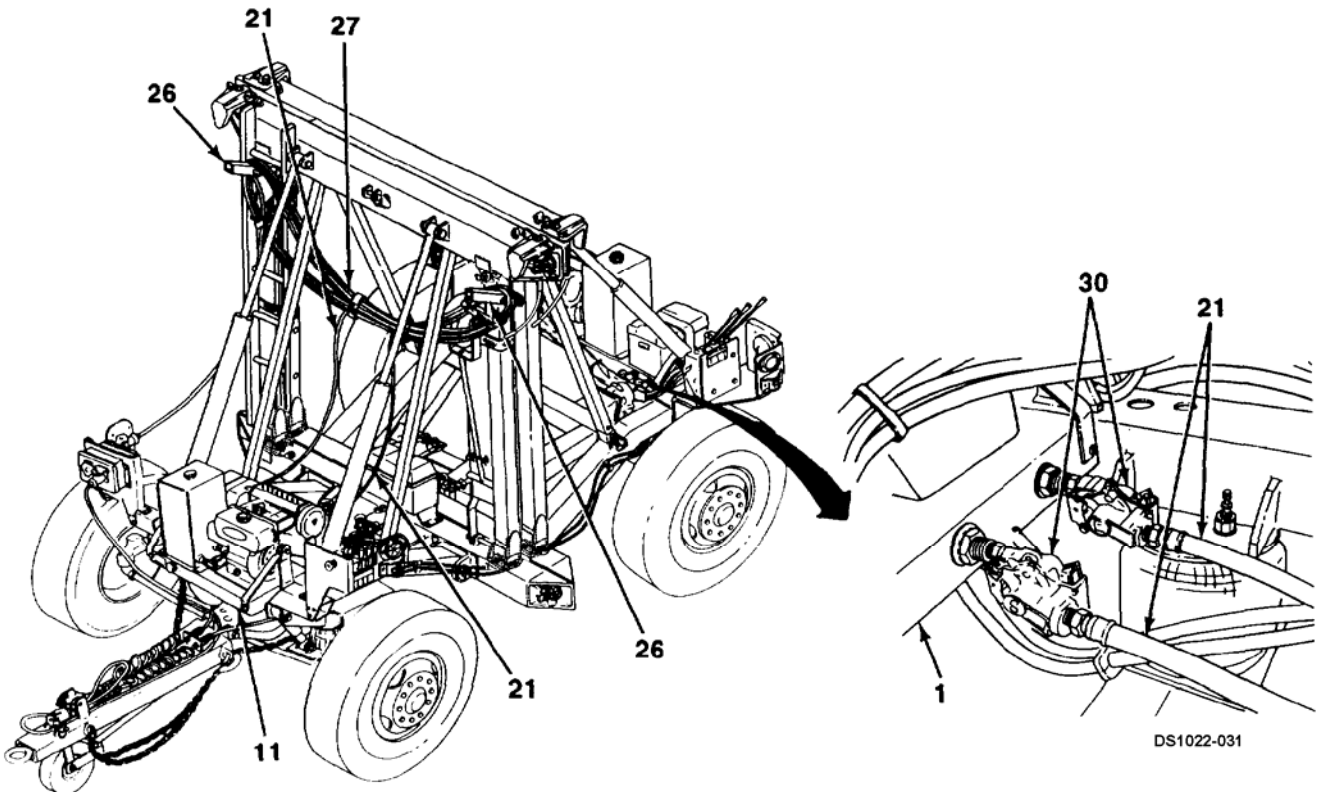
**2-7. UNCOUPLING DOLLY SET WITH OR WITHOUT SHELTER FROM TOWING VEHICLE (Cont).**

- I. Disconnect intradolly air hoses (21) from gladhands (30) at pivoting trays (1 and 11).

**NOTE**

**If uncoupling dolly set without shelter, perform step m.**

- m. Stow ends of intradolly air hoses (21) by wrapping them around bundle (27) hanging from two hanger brackets (26).



---

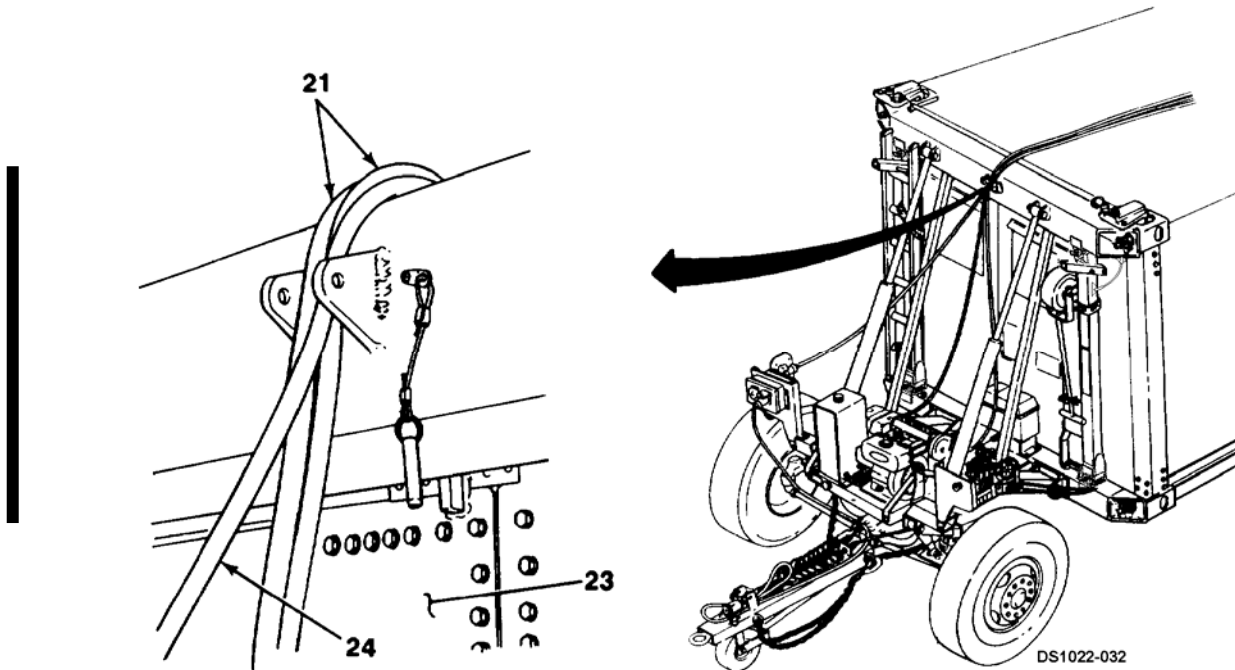
**2-7. UNCOUPLING DOLLY SET WITH OR WITHOUT SHELTER FROM TOWING VEHICLE (Cont).**

---

**NOTE**

**If uncoupling dolly set with shelter, perform step n.**

- n. Remove intradolly air hoses (21) from roof of shelter (23) and set aside.



**NOTE**

**If uncoupling a front dolly set after tandem towing, skip steps o through q.**

- o. Disconnect intradolly cable (24) from forward junction box (25) and rear junction box (29).

**NOTE**

**If uncoupling dolly set without shelter, perform step p.**

- p. Stow ends of intradolly cable (24) by wrapping them around bundle (27) hanging from two hanger brackets (26).

---

**2-7. UNCOUPLING DOLLY SET WITH OR WITHOUT SHELTER FROM TOWING VEHICLE (Cont).**

---

**NOTE**

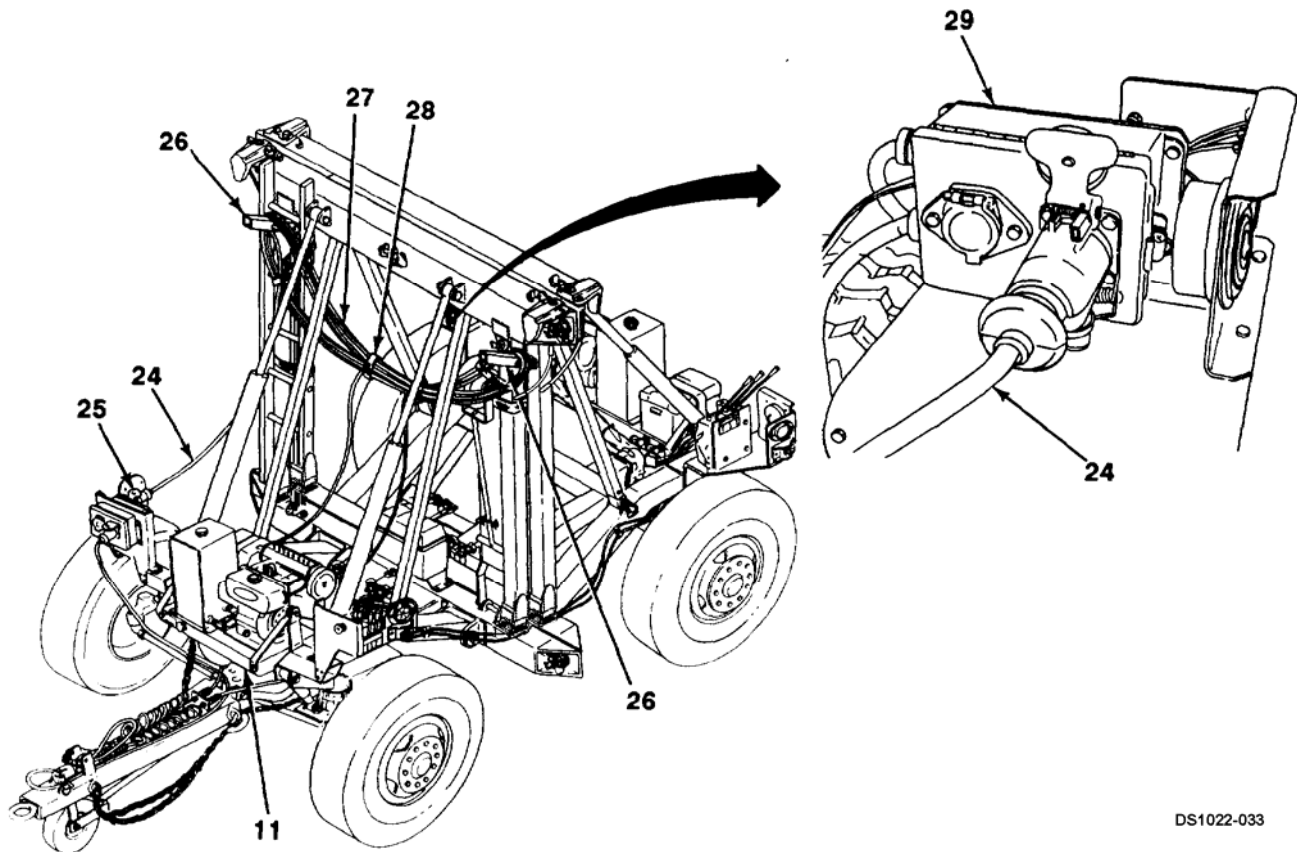
If uncoupling dolly set with shelter, perform step q.

- q. Remove intradolly cable (24) from roof of shelter (23) and set aside.

**NOTE**

If uncoupling dolly set without shelter, perform step r.

- r. Remove two stowage straps (28) and bundle (27) from two hanger brackets (26) on front dolly. Set items aside.



DS1022-033

---

**2-8. LOWERING DOLLY SET WITH OR WITHOUT SHELTER AND DETACHING FRONT AND REAR DOLLIES**

---

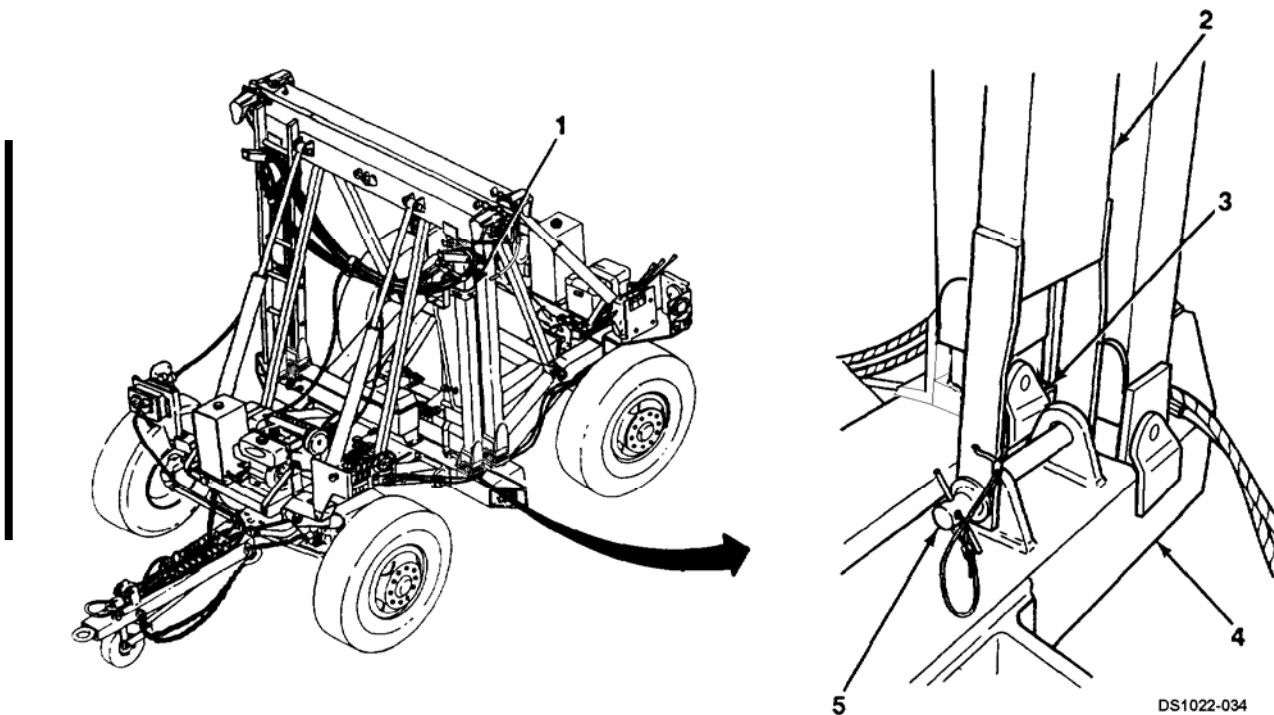
**WARNING**

All personnel must use caution when standing near front and rear dollies during attaching operations. Failure to follow this warning may cause serious injury or death to personnel.

**NOTE**

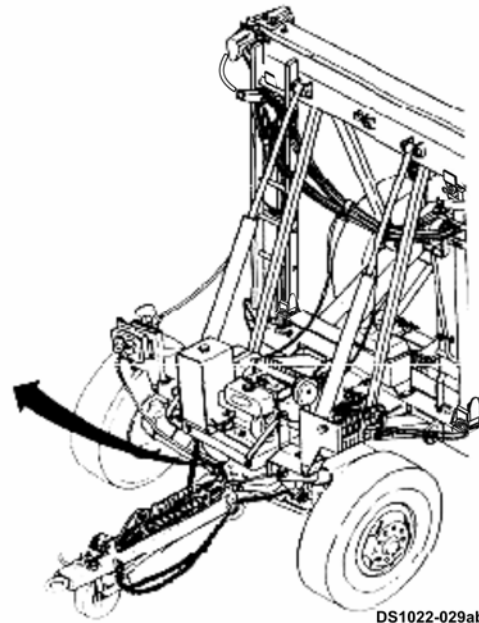
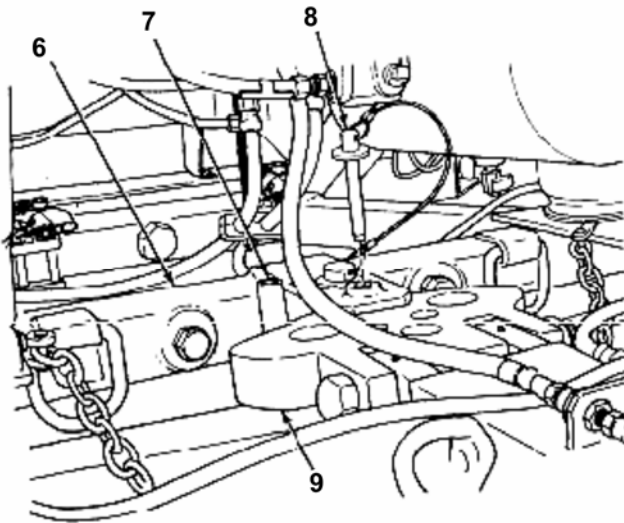
Procedures to lower dolly set, with or without shelter, and detach front and rear dollies are similar. Differences will be identified as they occur.

- a. Remove stowage strap (1), lockpin (3), and pin (5), and remove rear drawbar (2) from stowage on bottom beam (4) of front dolly.



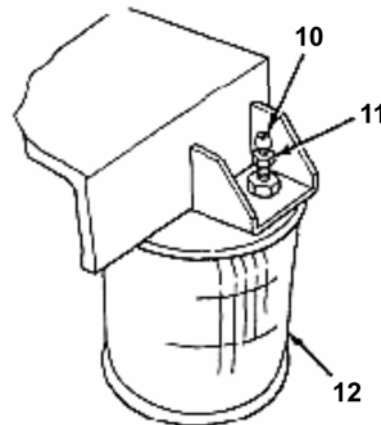
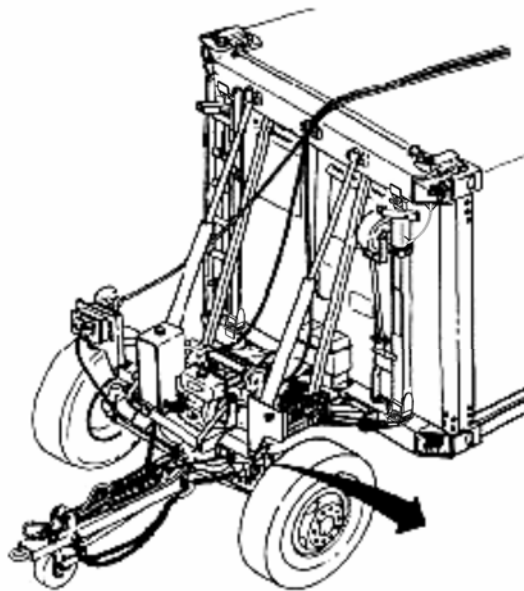
**2-8. LOWERING DOLLY SET WITH OR WITHOUT SHELTER AND DETACHING FRONT AND REAR DOLLIES (Cont).**

b. Remove steering locking pin (8) from stowage tube (7). Install steering locking pin through front axle (6) and steering link (9) to lock steering.



DS1022-029ab

c. At front and rear, remove two caps (10) of air bag valves (11) and deflate air bags (12). Install caps on air bag valves.



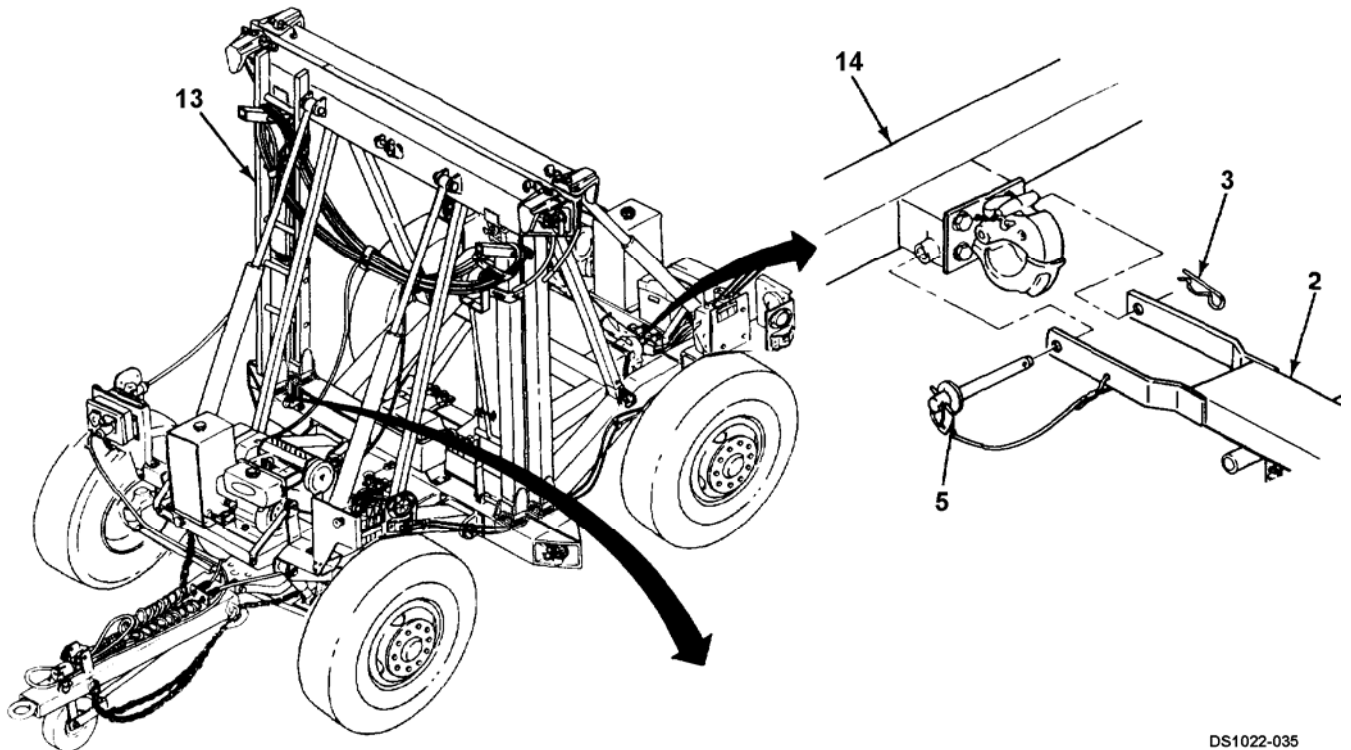
DS1022-115





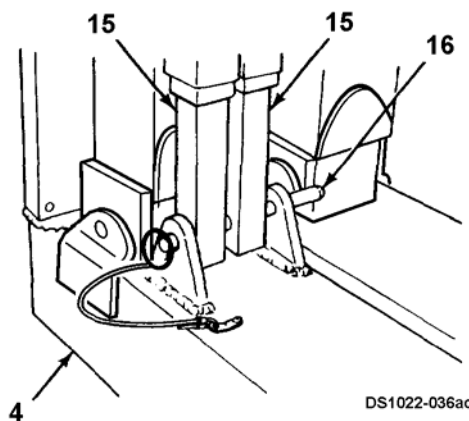
**2-8. LOWERING DOLLY SET WITH OR WITHOUT SHELTER AND DETACHING FRONT AND REAR DOLLIES (Cont).**

- d. Install rear drawbar (2) to rear axle (14) with pin (5) and lockpin (3).
- e. Remove two stowage straps and ladder (13). Set ladder aside.



DS1022-035

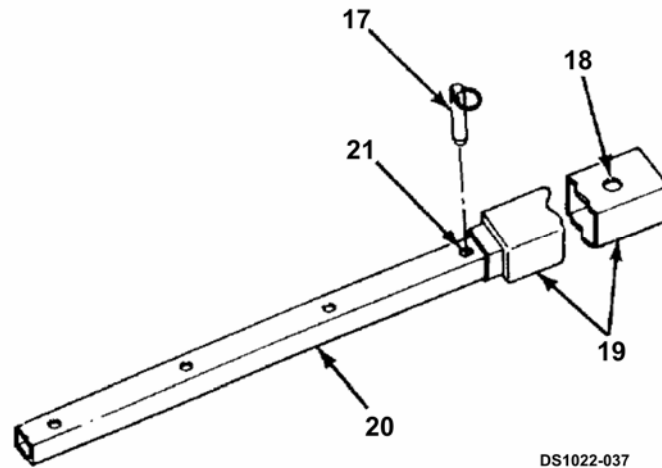
- f. Remove stowage strap and detent pin (16), and remove two telescopic braces (15) from stowage on bottom beam (4) of front dolly.



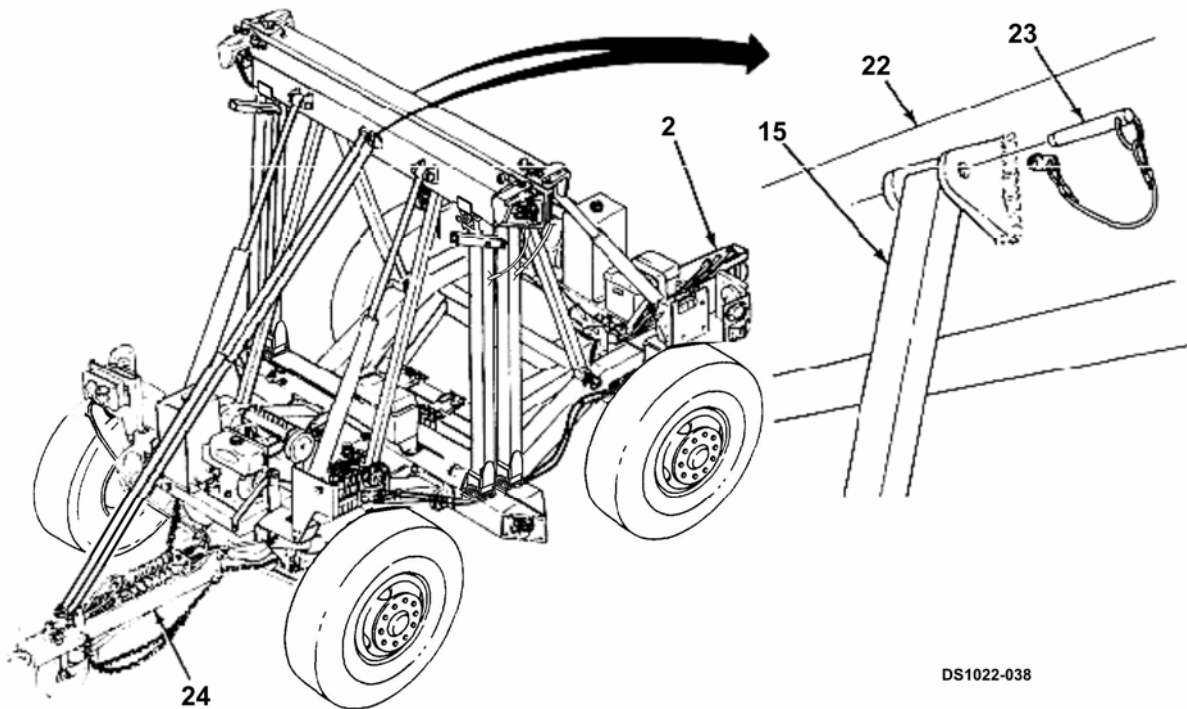
DS1022-036ac

**2-8. LOWERING DOLLY SET WITH OR WITHOUT SHELTER AND DETACHING FRONT AND REAR DOLLIES (Cont).**

g. Remove rest pin (17) from hole (18) at end of each larger brace (19). Install rest pin in fourth hole (21) from end of each smaller brace (20).



h. Install two telescopic braces (15) to front and rear drawbars (24 and 2) and top beams (22) with four detent pins (23).

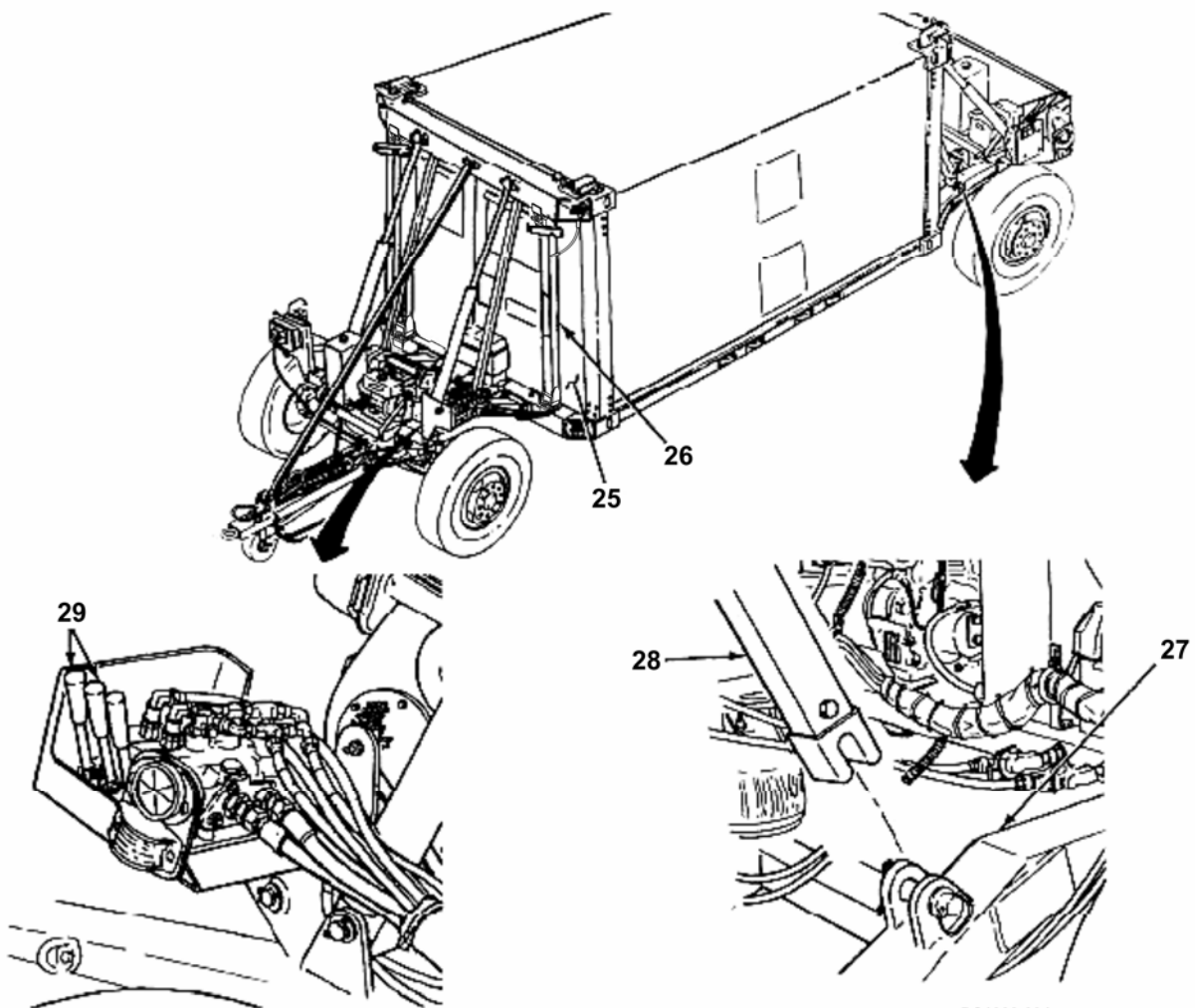


---

**2-8. LOWERING DOLLY SET WITH OR WITHOUT SHELTER AND DETACHING FRONT AND REAR DOLLIES (Cont).**

---

- i. Start engine at front and rear dollies (see paragraph 2-20).
- j. At front and rear, pull down on two-lift cylinder levers (29) to slightly extend lift cylinders. Disengage transportation lockouts (28) from suspension links (27). Secure each transportation lockout to top beam vertical tube (26) with stowage strap.
- k. At front and rear, push up on two lift cylinder levers (29) and lower dolly set with or without shelter (25) to the ground.



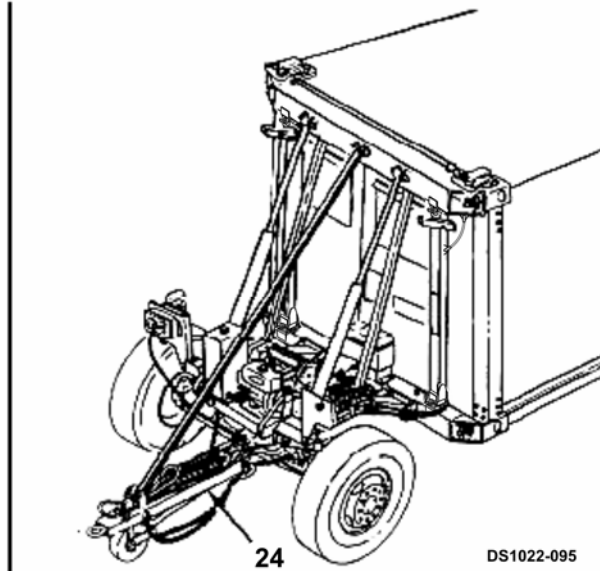
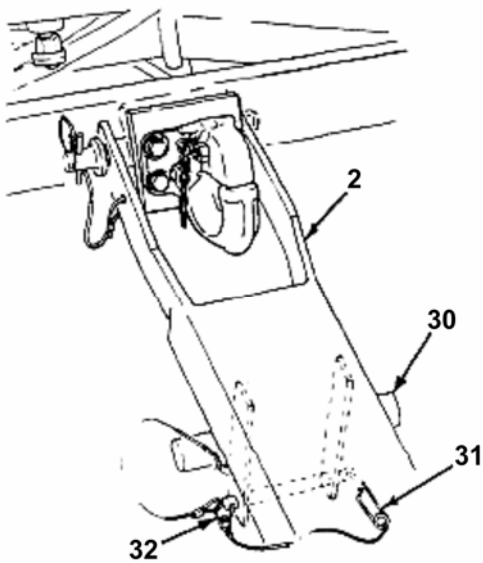
DS1022-094

---

**2-8. LOWERING DOLLY SET WITH OR WITHOUT SHELTER AND DETACHING FRONT AND REAR DOLLIES (Cont).**

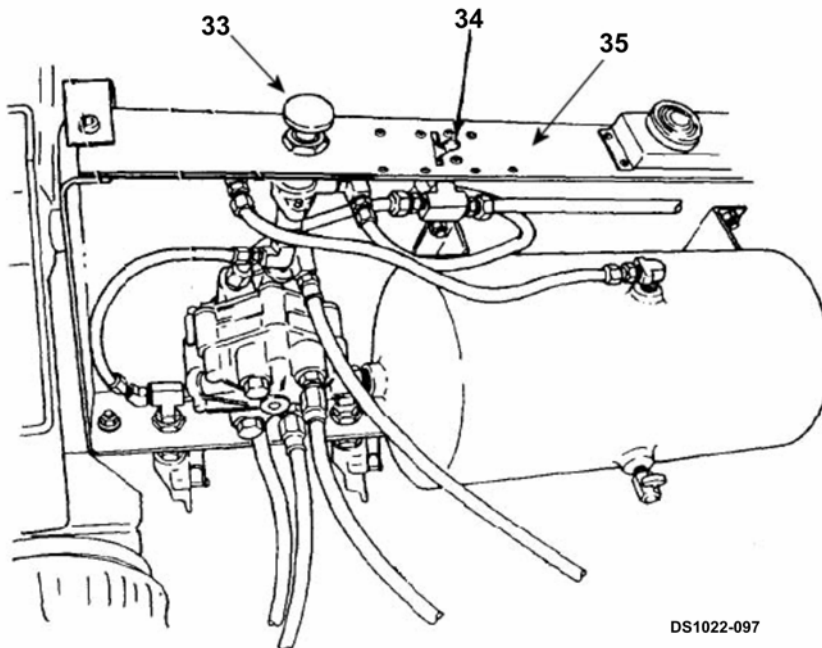
---

- i. Remove safety pin (31) and hitch pin (32) and release handle (30) from stowage under rear drawbar (2).
- (2). Repeat for handle at front drawbar (24).



DS1022-095

- m. Release brakes on rear dolly by pushing in on airbrake control knob (33) and turning parking brake lever (34) on pivoting tray (35) to OFF position.



DS1022-097

## 2-8. LOWERING DOLLY SET WITH OR WITHOUT SHELTER AND DETACHING FRONT AND REAR DOLLIES (Cont).

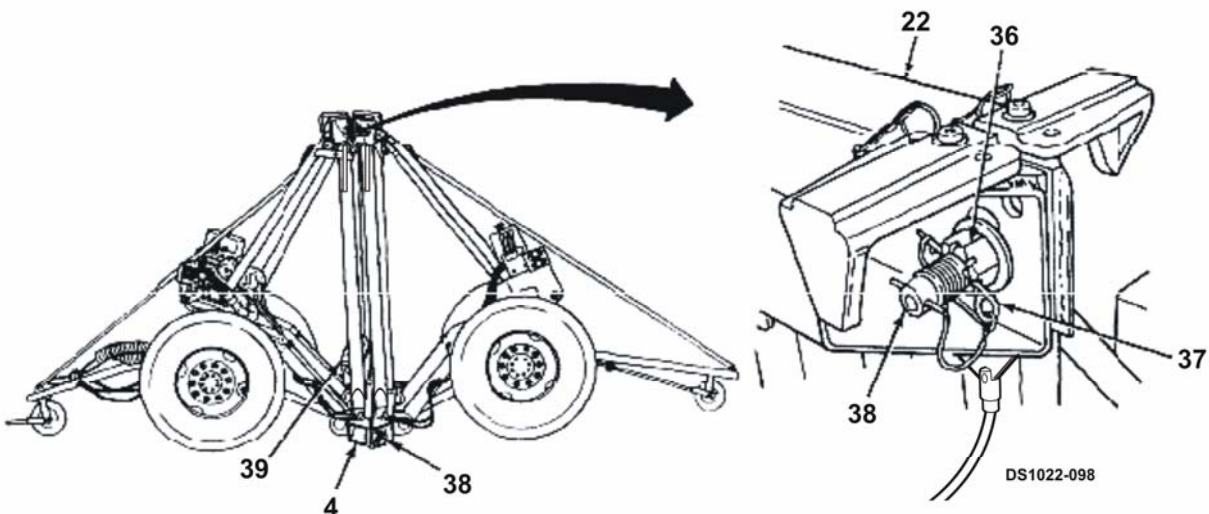
### WARNING

- Use extreme caution when removing twist locks. Keep hands and/or feet clear of top hooks, top and bottom beams, and from between beams and shelter. Failure to follow this warning may cause serious injury to personnel.
- Use extreme caution when loosening and removing twist locks. Loosened twist locks at top beam **MUST** be removed or they may fall, causing serious injury to personnel.
- Use extreme caution when using ladder. Have an assistant hold ladder to ensure that it is stable. Failure to follow this warning may cause serious injury to personnel.

### NOTE

- If there is difficulty loosening twist lock nut or twist locks do not come out, it may be necessary to operate hydraulic control valve to slightly retract or extend each lift cylinder (see paragraph 2-21).
- If detaching dolly halves from each other, perform step n. Skip remaining steps in task.
- If detaching dolly halves from shelter, skip step n and perform steps o through S.

n. At front and rear, remove safety pins (37). Use twist lock wrench (Item 3, Appendix D) to loosen nuts (36) at top beams (22). Rotate twist locks (38) 90° and remove from top beams. Repeat to remove from bottom beams (4). Stow twist locks in toolbox (39) on front dolly.



**2-8. LOWERING DOLLY SET WITH OR WITHOUT SHELTER AND DETACHING FRONT AND REAR DOLLIES (Cont).**

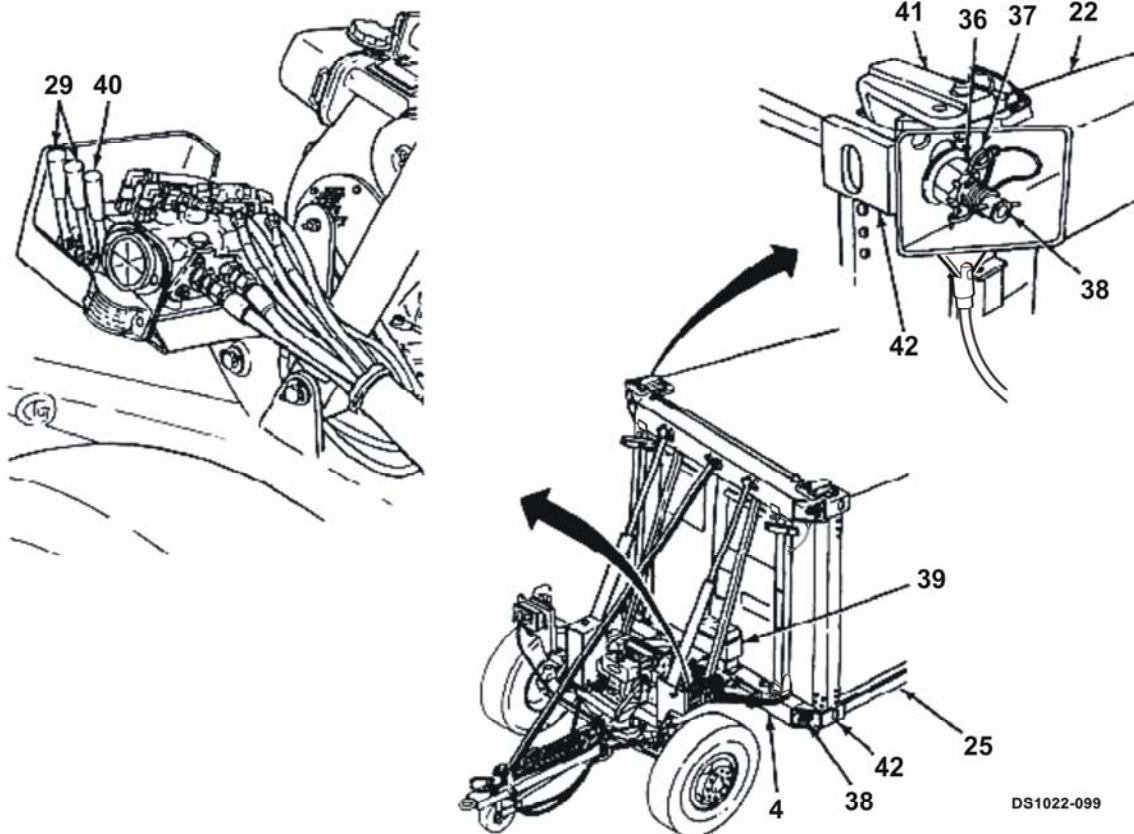
o. At front and rear, remove safety pins (37). Use twist lock wrench (Item 3, Appendix A) to loosen nuts (36) at top and bottom beams (22 and 4). Rotate twist locks (38) 90° and remove from top beams and shelter (25). Stow removed twist locks in toolbox (39) on front dolly.

p. At bottom beams (4) rotate twist locks (38) 90°. Pull out, but DO NOT remove twist locks. Ensure that heads of twist locks are aligned with holes in corner blocks (42) of shelter (25).

q. At front and rear, pull down on two lift cylinder levers (29) to extend lift cylinders. Stop when bottom beam (4) is approximately 6 in. (15 cm) from shelter (25) and twist locks (38) are free of corner blocks (42).

r. At front and rear, pull down on positioning cylinders lever (40) until bottom beam (4) rests on the ground.

s. At front and rear, briefly pull down on two lift cylinder levers (29) and then briefly pull down on positioning cylinders lever (40). Repeat as required until top hooks (41) are clear of corner blocks (42) at top of shelter (25).



DS1022-099

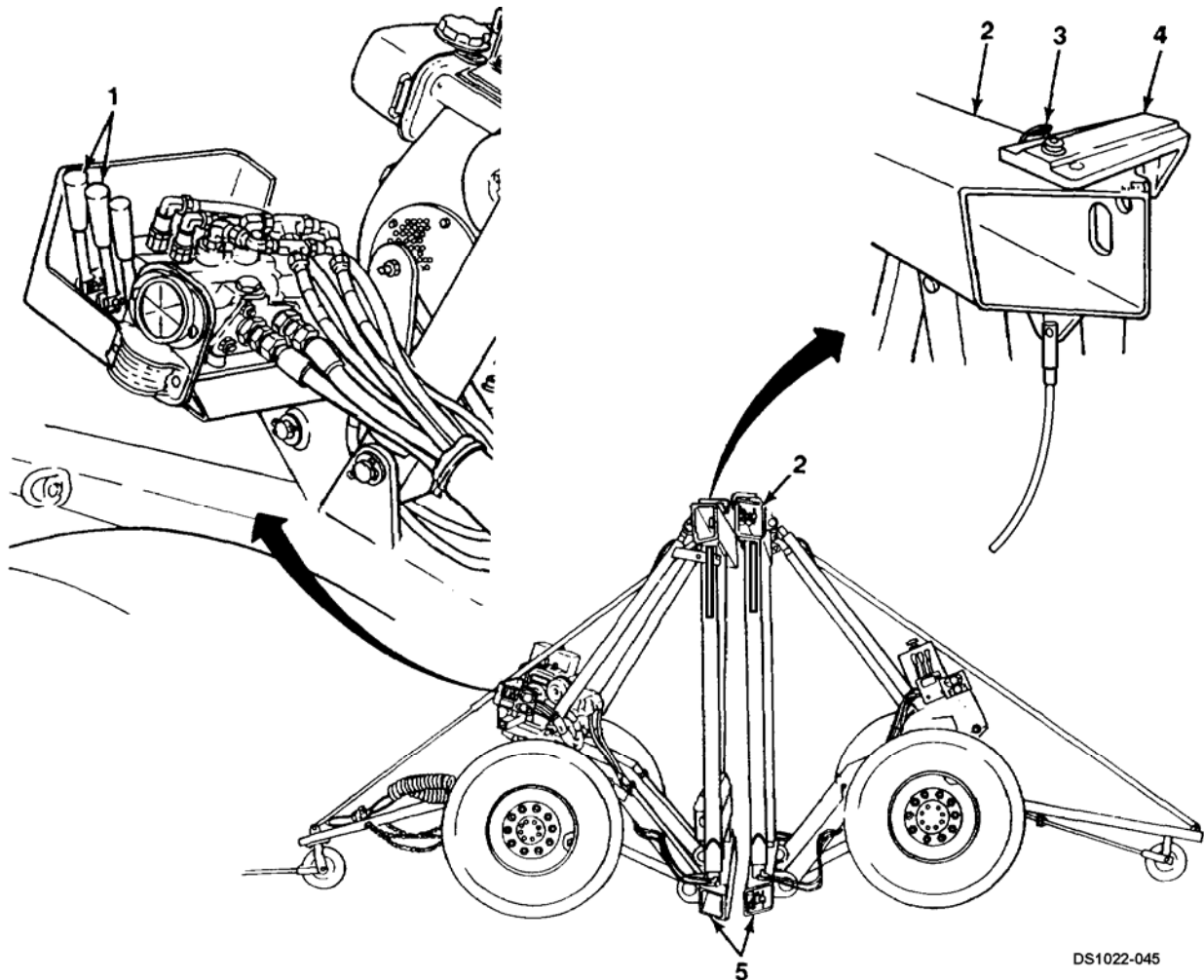
---

**2-9. ATTACHING FRONT AND REAR DOLLIES TO SHELTER.**

---

**WARNING**

- All personnel must use caution when standing near front and rear dollies and shelter during attaching operations. Failure to follow this warning may cause serious injury or death to personnel.
  - Use extreme caution when using ladder. Have an assistant hold ladder to ensure that it is stable. Failure to follow this warning may cause serious injury to personnel.
- a. At front and rear, pull down on two lift cylinder levers (1) to separate front and rear dollies approximately 12 in. (30 cm). Push up on lift cylinder levers to bring top and bottom beams (2 and 5) back to the vertical position.
- b. At front and rear top beams (2), remove two detent pins (3) and rotate top hooks (4) 180° to shelter engagement position. Install detent pins.
- c. Place each dolly half in maneuvering position (see paragraph 2-21b).



DS1022-045

**2-9. ATTACHING FRONT AND REAR DOLLIES TO SHELTER (Cont).**

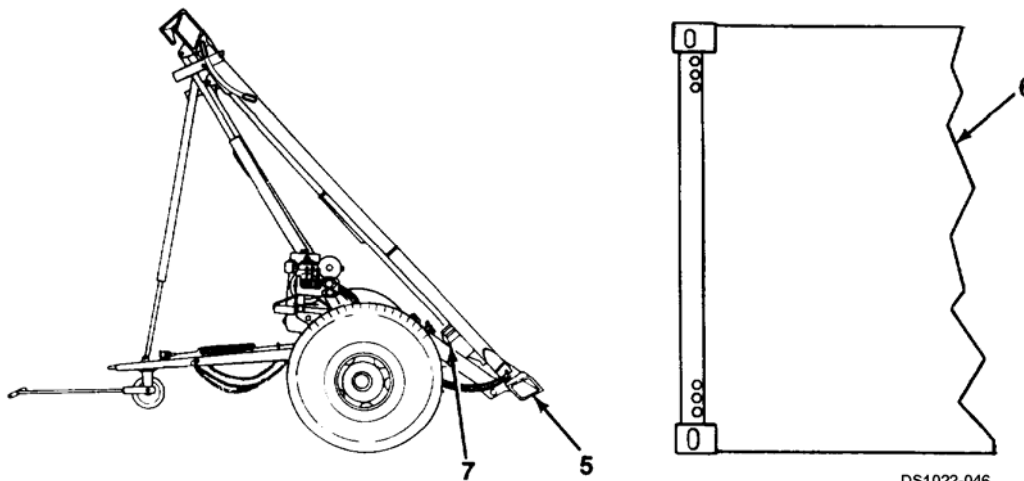
**WARNING**

While In maneuvering position, **DO NOT** operate positioning cylinders lever. Failure to follow this warning may cause bottom beam to lower to the ground, causing serious Injury to personnel.

**NOTE**

To ensure access into shelter through its door, rear dolly must be attached to door end of shelter.

- d. Move each dolly half into position at ends of shelter (6). Bottom beam (5) should be approximately 6 in. (15 cm) from shelter and alined with sides of shelter.
- e. Remove each dolly half from maneuvering position (see paragraph 2-21 c).



**NOTE**

If operating on uneven terrain, refer to paragraph 2-32 for Instructions on unlocking the axle-to-pivot axle bracket coupling.

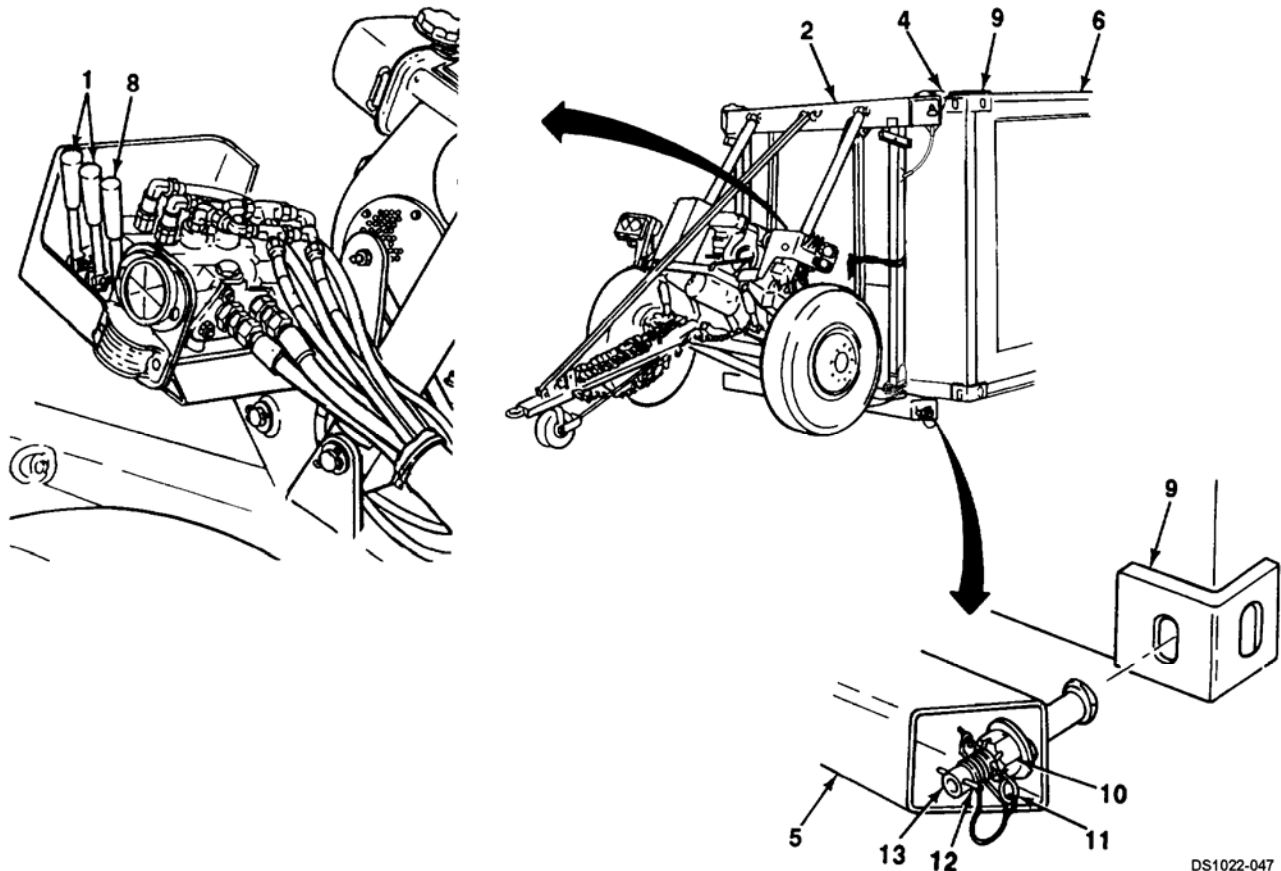
- f. Remove eight twist locks (13) from toolbox (7). At front and rear, loosely install two twist locks to bottom beams (5).
- g. At front and rear, operate two lift cylinder levers (1) and positioning cylinders lever (8) to extend and/or retract lift and positioning cylinders as required to engage two top hooks (4) into corner blocks (9) at top of shelter (6).
- h. At front and rear, push up on positioning cylinders lever (8) to raise bottom beam (5) 1-2 in. (3-5 cm) off the ground.
- i. At front and rear, push up on two lift cylinder levers (1) to draw bottom beam (5) to within approximately 2 in. (5 cm) of shelter (6).



---

**2-9. ATTACHING FRONT AND REAR DOLLIES TO SHELTER (Cont).**


---



DS1022-047

- j. At front and rear, extend or retract positioning cylinders as required to align twist locks (13) in bottom beam (5) with holes in corner blocks (9) of shelter (6). When aligned, push twist locks into corner blocks.
- k. At front and rear, push up on two lift cylinder levers (1) to bring bottom beam (5) flush against shelter (6).

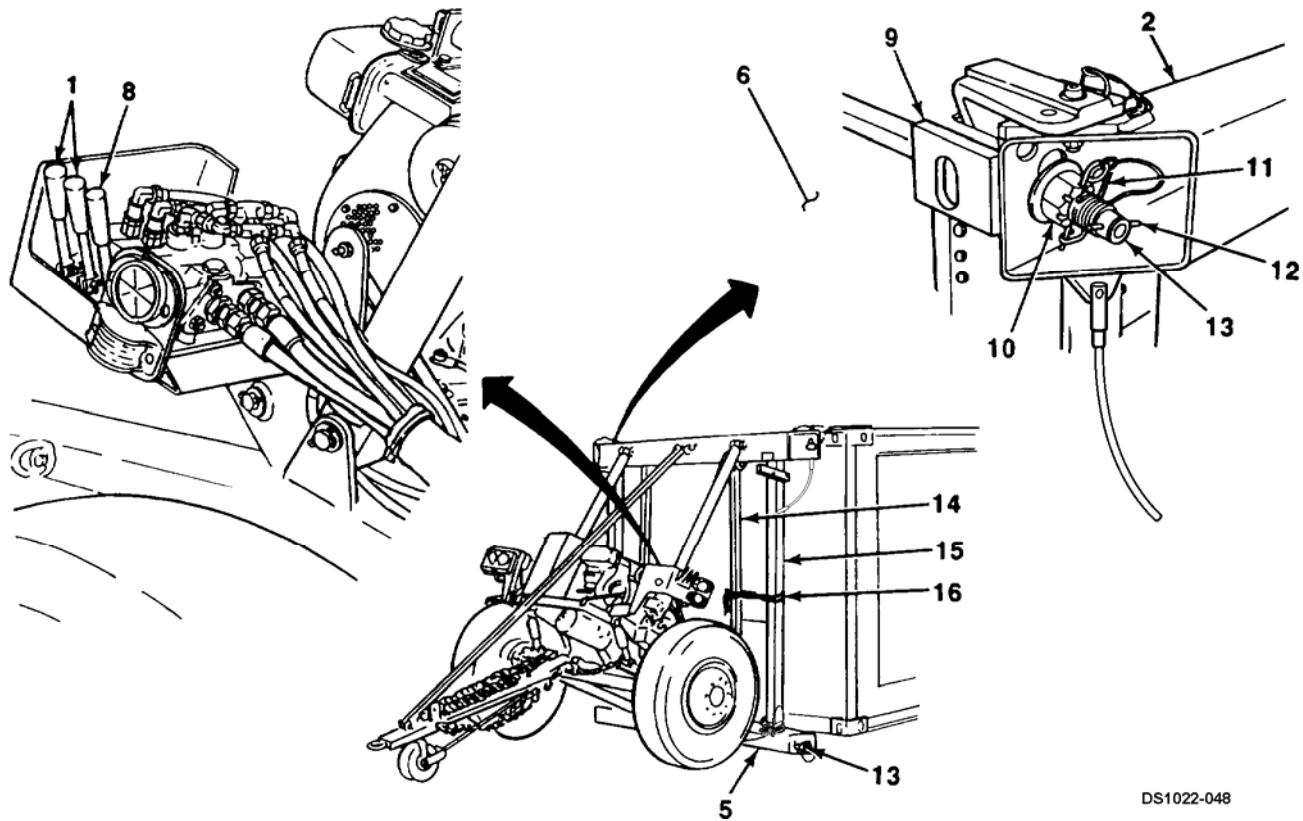
**WARNING**

**Use extreme caution when installing twist locks. Keep hands and/or feet clear of top hooks, top and bottom beams, and from between beams and shelter. Failure to follow this warning may cause serious injury to personnel.**

- l. At front and rear, ensure that twist locks (13) are fully pushed into corner blocks (9) in bottom of shelter (6). Rotate twist locks 90° so that twist lock pins (12) are horizontal. Tighten nuts (10) finger-tight.
- m. At front and rear, push up on positioning cylinders lever (8) and raise bottom beam (5) to force heads of twist locks (13) up against top on inside of corner blocks (9). Use twist lock wrench (Item 3, Appendix D) to tighten nuts (10). Install safety pins (11) through twist locks to secure nuts.

**2-9. ATTACHING FRONT AND REAR DOLLIES TO SHELTER (Cont).**

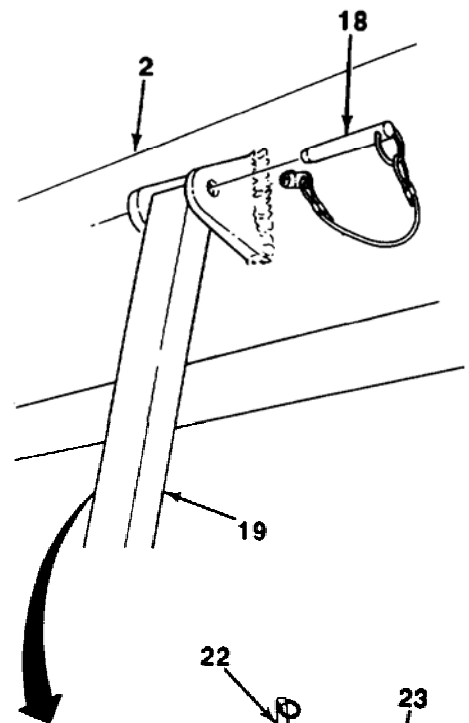
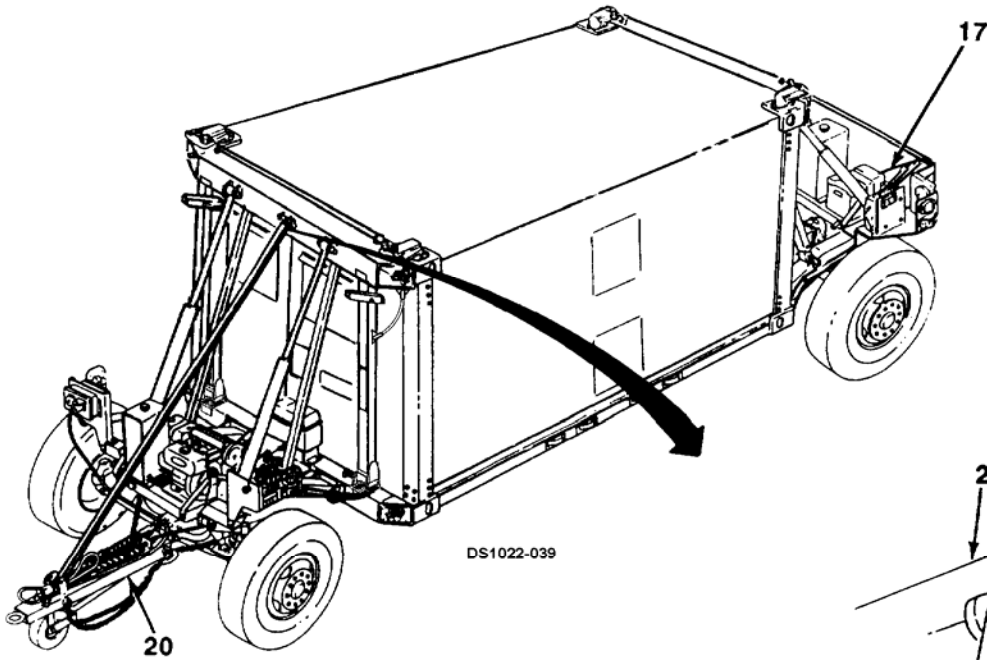
- n. At front and rear, install two twist locks (13) to top beams (2) and shelter (6). Rotate twist locks 90° so that twist lock pins (12) are horizontal. Tighten nuts (10) finger-tight.
- o. At front and rear, pull down on two lift cylinder levers (1) to ensure that top beam (2) is flush against shelter (6).
- p. At front and rear, pull down on positioning cylinders lever (8) to raise top beam (2) to force heads of twist locks (13) up against top on inside of corner blocks (9). Use twist lock wrench (Item 3, Appendix D) to tighten nuts (10).
- q. Check all twist locks (13) at top and bottom beams (2 and 5). Twist lock pins (12) must be horizontal. Tighten nuts (10) as required. Install safety pins (11) through twist locks to secure nuts.
- r. Remove stowage strap (16) from each transportation lockout (14) and top beam vertical tube (15).



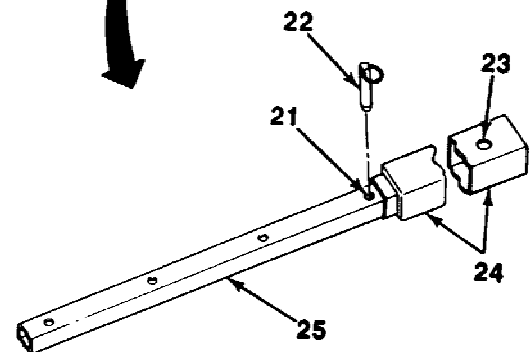
DS1022-048

**2-9. ATTACHING FRONT AND REAR DOLLIES TO SHELTER (Cont).**

s. Remove four detent pins (18) and two telescopic braces (19) from front and rear drawbars (20 and 17) and top beams (2).

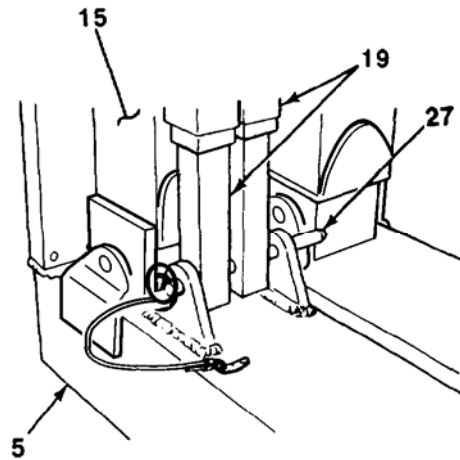
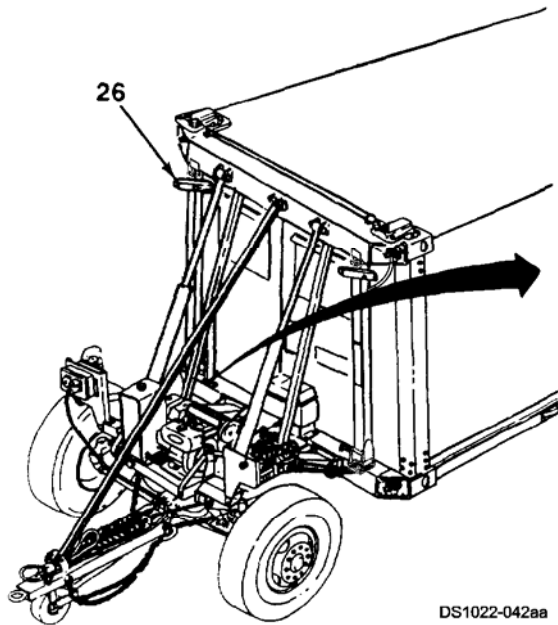


t. Remove rest pin (22) from fourth hole (21) from end of each smaller brace (25). Install rest pin in hole (23) at end of each larger brace (24).



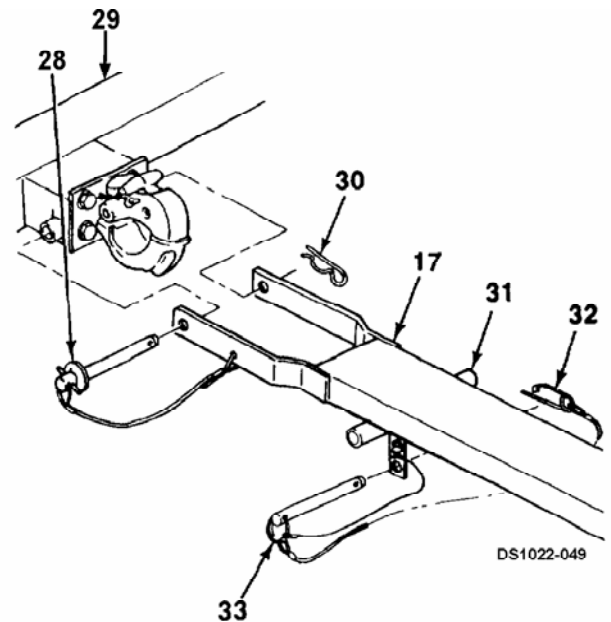
2-9. ATTACHING FRONT AND REAR DOLLIES TO SHELTER (Cont).

u. Stow two telescopic braces (19) on bottom beam (5) of front dolly with detent pin (27). Heads of rest pins positioned in step t should be facing each other. Secure larger brace end of telescopic braces with stowage strap. Locate stowage strap around telescopic braces and top beam vertical tube (15) approximately 1 foot (30 cm) **BELOW** hanger bracket (26).



v. Stow handle (31) under rear drawbar (17) and secure with hitch pin (33) and safety pin (32).

w. Remove lockpin (30), pin (28), and rear drawbar (17) from rear axle (29).



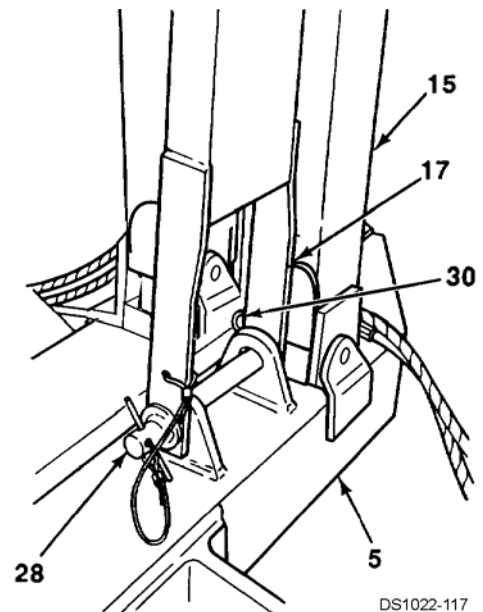
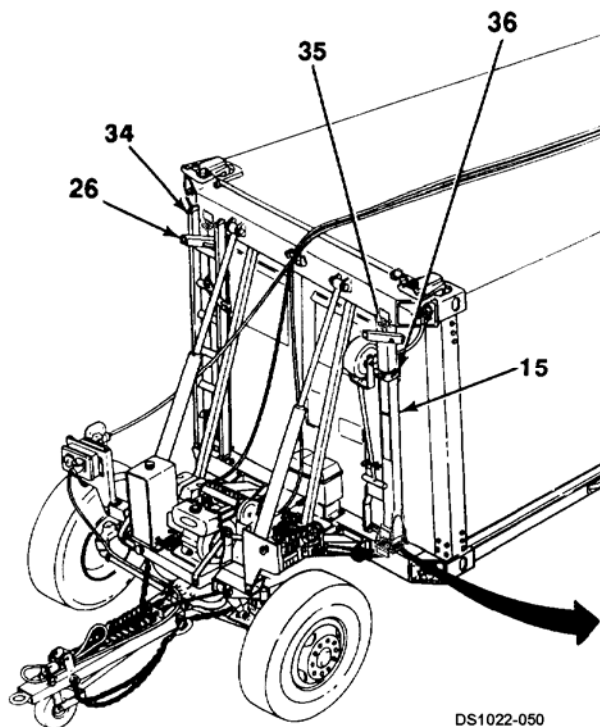
---

**2-9. ATTACHING FRONT AND REAR DOLLIES TO SHELTER (Cont).**

---

x. Stow rear drawbar (17) on bottom beam (5) of front dolly with pin (28) and lockpin (30). Secure rear drawbar with stowage strap (36). Locate stowage strap around rear drawbar and top beam vertical tube (15) approximately 1 foot (30 cm) **BELOW** hanger bracket (35).

y. Hang ladder (34) on hanger bracket (26) and secure with two stowage straps. Locate one strap around bottom rung of ladder and top beam vertical tube (15). Locate other strap around second rung from top of ladder and top beam vertical tube.



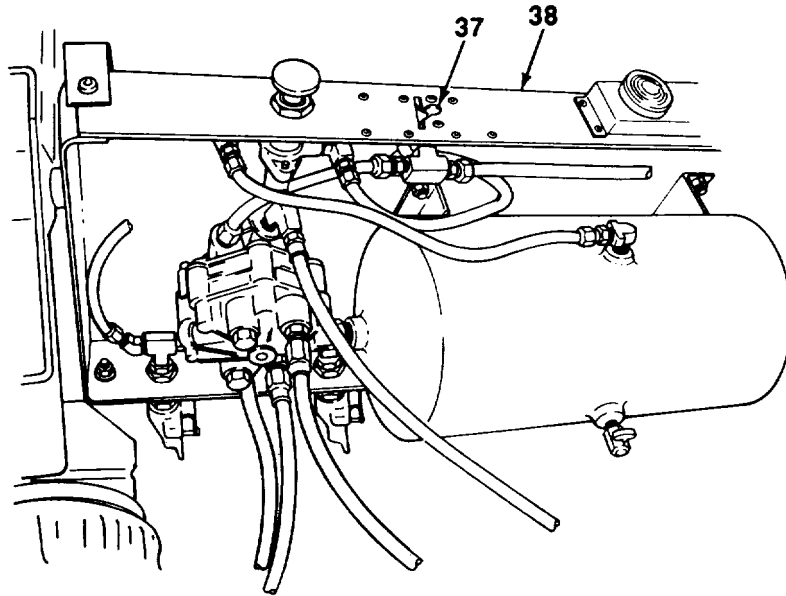
DS1022-117

---

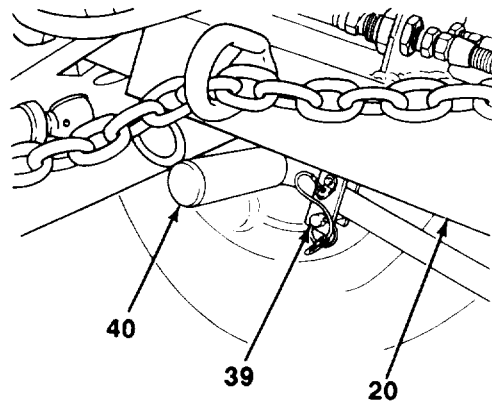
**2-9. ATTACHING FRONT AND REAR DOLLIES TO SHELTER (Cont).**

---

- z. Apply parking brakes on rear dolly by turning parking brake lever (37) on pivoting tray (38) to ON position.



- aa. Stow handle (40) under front drawbar (20) and secure with hitch pin (39) and safety pin.



---

**2-10. ATTACHING FRONT AND REAR DOLLIES TO EACH OTHER.**

---

**WARNING**

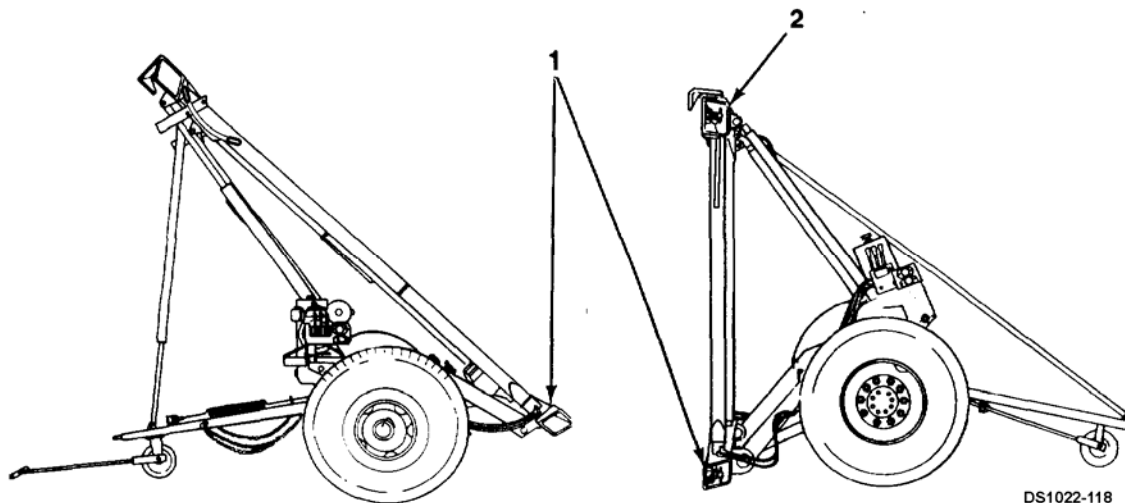
All personnel must use caution when standing near front and rear dollies during attaching operations. Failure to follow this warning may cause serious Injury or death to personnel.

- a. Place each dolly half in maneuvering position (see paragraph 2-21b).

**WARNING**

While in maneuvering position, **DO NOT** operate positioning cylinders lever. Failure to follow this warning may cause bottom beam to lower to the ground, causing serious Injury to personnel.

- b. Move rear dolly to desired location as required.
- c. Remove rear dolly from maneuvering position and place with top and bottom beams (2 and 1) in vertical position (see paragraph 2-21 c).
- d. Position front dolly at rear dolly. Bottom beam (1) of front dolly should be within 6 in. (15 cm) of vertical of top and bottom beams (2 and 1) of rear dolly.



FRONT DOLLY

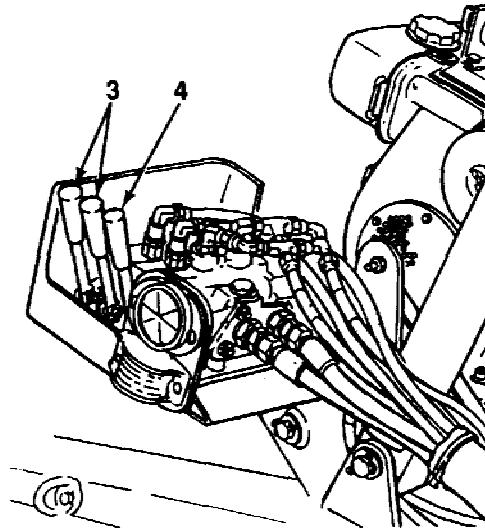
REAR DOLLY

---

## 2-10. ATTACHING FRONT AND REAR DOLLIES TO EACH OTHER (Con't).

---

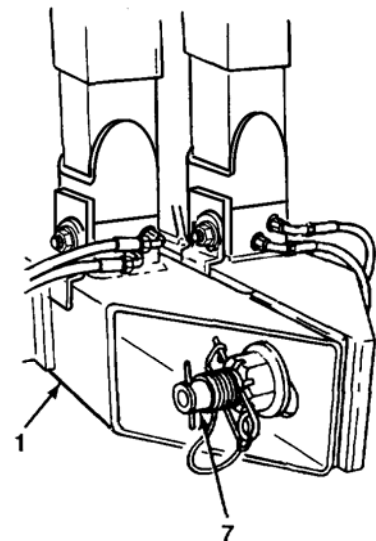
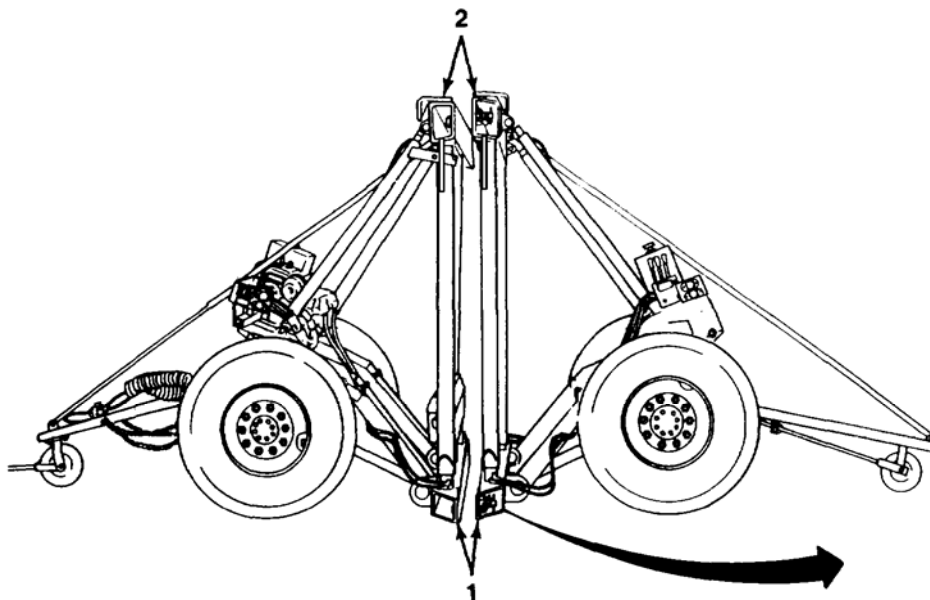
e. At front dolly, push up on two lift cylinder levers (3) and lower bottom beam (1) to within 6 in. (15 cm) of the ground.



f. Aline bottom beam (1) of front dolly with bottom beam of rear dolly.

g. Complete operation of removing front dolly from maneuvering position. Place top and bottom beams (2 and 1) in vertical position (see paragraph 2-21c).

h. At rear dolly, rotate two twist locks (7) 90° and remove from bottom beam (1).



DS1022-178



---

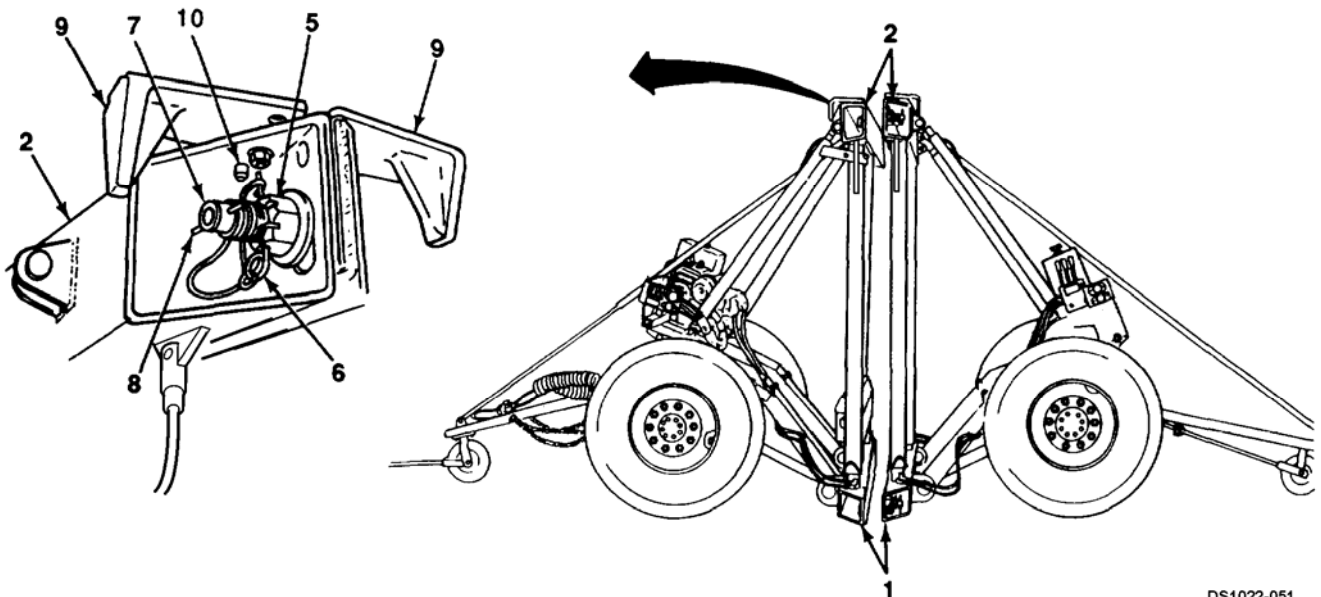
**2-10. ATTACHING FRONT AND REAR DOLLIES TO EACH OTHER (Con't).**


---

**WARNING**

**Use extreme caution when using ladder. Have an assistant hold ladder to ensure that it is stable. Failure to follow this warning may cause serious injury to personnel.**

- i. At front and rear dolly top beams (2) remove two detent pins (10) and rotate top hooks (9) 180° away from shelter engagement position. Install detent pins.
- j. At front dolly, pull down on two lift cylinder levers (3) and then pull down on positioning cylinders lever (4) until top beam (2) contacts and aligns with top beam of rear dolly.



DS1022-051

**WARNING**

**Use extreme caution when installing twist locks. Keep hands and/or feet clear of top hooks, top and bottom beams, and from between beams. Failure to follow this warning may cause serious injury to personnel.**

- k. At front and rear dolly top beams (2) install two twist locks (7). Rotate twist locks 90° so that twist lock pins (8) are horizontal. Tighten nuts (5) with twist lock wrench (Item 3, Appendix D). Install safety pins (8) through twist locks to secure nuts.
- l. At front dolly, push up on positioning cylinders lever (4) to raise bottom beam (1) 1-2 in. (3-5 cm) off the ground.
- m. At front dolly, push up on two lift cylinder levers (3) to draw in bottom beam (1) as close as possible to bottom beam of rear dolly.
- n. At front dolly, pull down on positioning cylinders lever (4) to align holes in bottom beam (1) with holes in bottom beam of rear dolly.

---

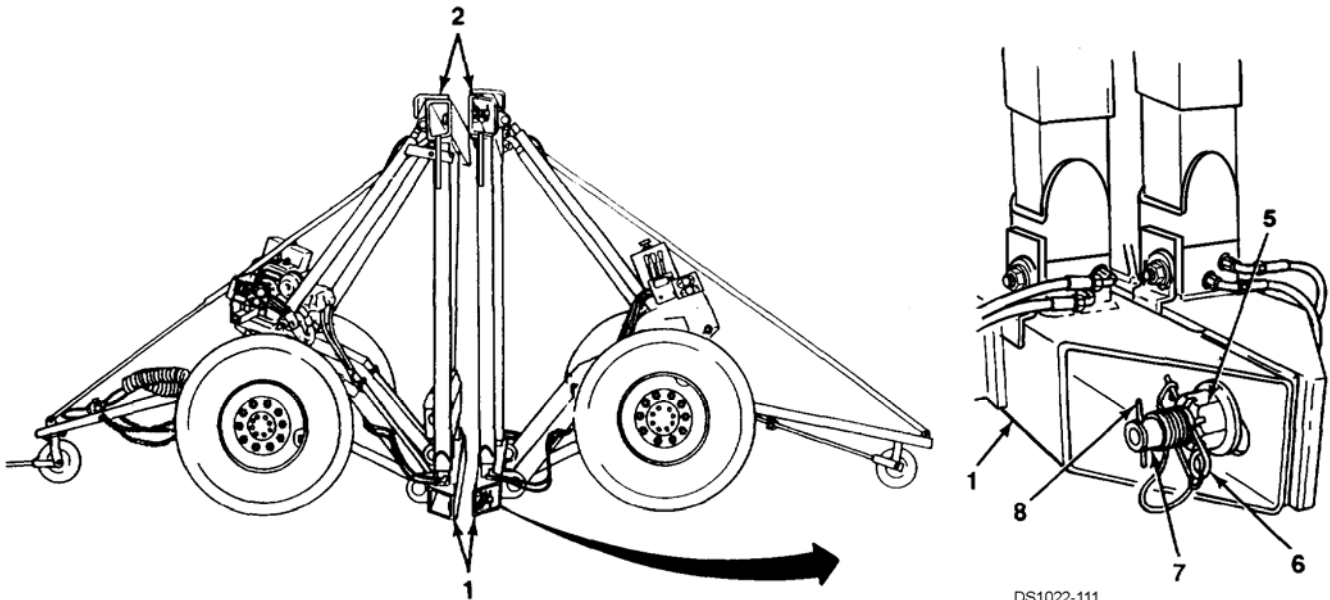
2-10. ATTACHING FRONT AND REAR DOLLIES TO EACH OTHER (Con't).

---

**WARNING**

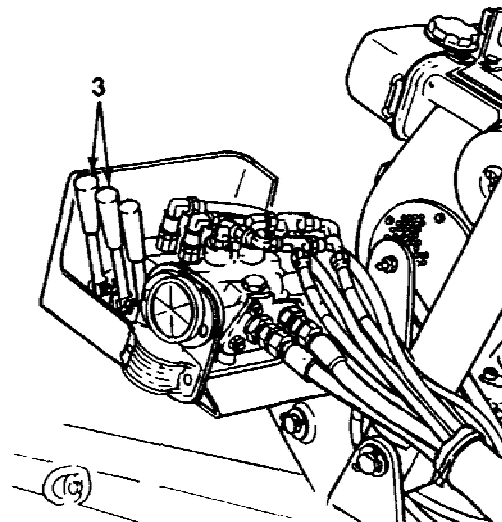
Use extreme caution when installing twist locks. Keep hands and/or feet clear of top hooks, top and bottom beams, and from between beams. Failure to follow this warning may cause serious injury to personnel.

- o. At front and rear dolly bottom beams (1), install two twist locks (7). Rotate twist locks 90° so that twist lock pins (8) are vertical. Tighten nuts (5) fingertight.



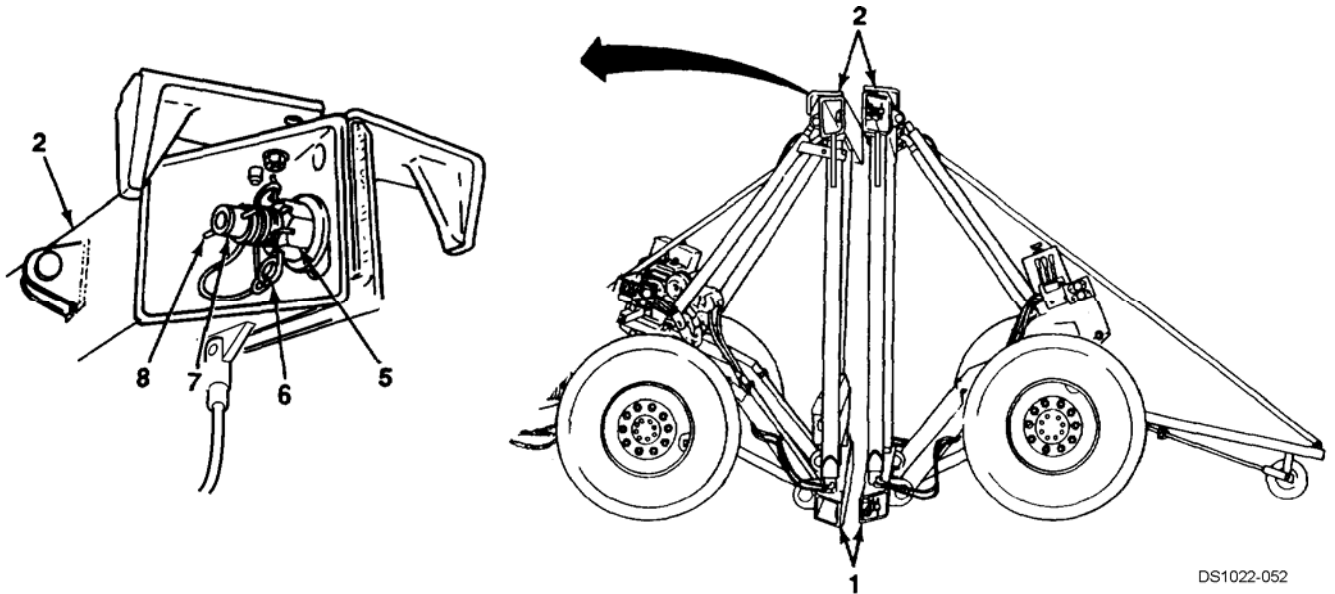
DS1022-111

- p. As required, push up on two rear dolly lift cylinder levers (3) to bring top and bottom beams (2 and 1) completely flush with each other and aligned.

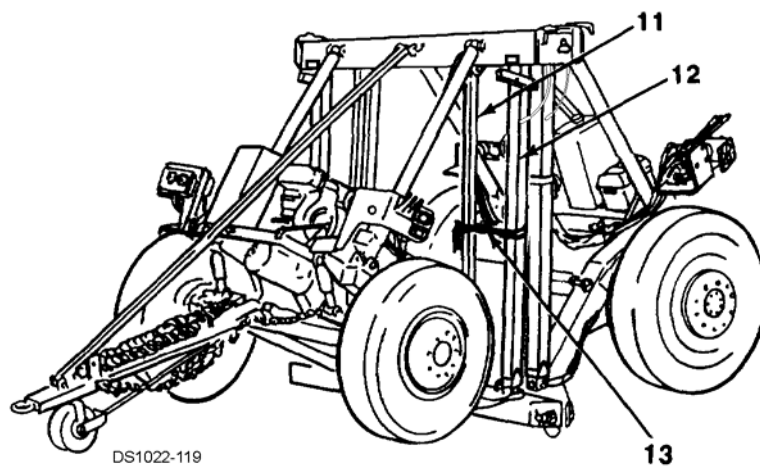


**2-10. ATTACHING FRONT AND REAR DOLLIES TO EACH OTHER (Con't).**

q. Check all twist locks (7) at top and bottom beams (2 and 1). Twist lock pins (8) at top beam must be horizontal. Twist lock pins at bottom beam must be vertical. Use twist lock wrench (Item 3, Appendix D) to tighten nuts (5). Install safety pins (6) through twist locks to secure nuts.



r. Remove stowage strap (13) from each transportation lockout (11) and top beam vertical tube (12).

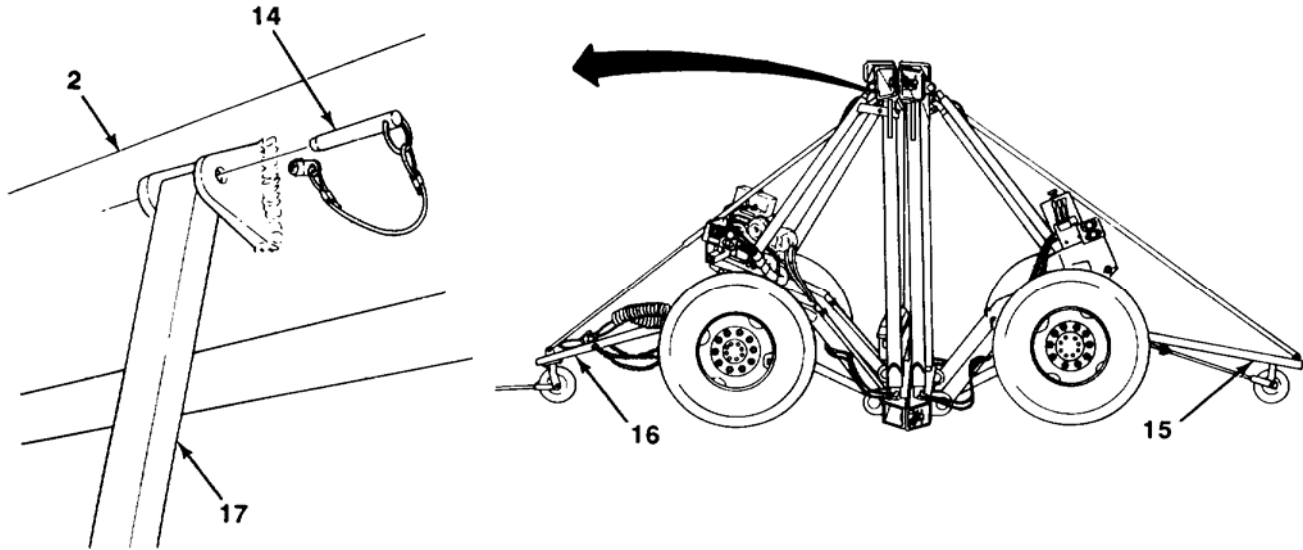


---

**2-10. ATTACHING FRONT AND REAR DOLLIES TO EACH OTHER (Con't).**

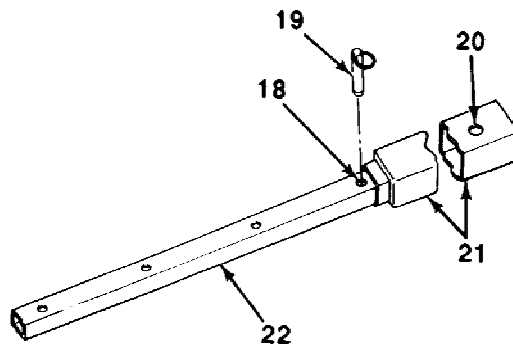
---

s. Remove four detent pins (14) and two telescopic braces (17) from front and rear drawbars (16 and 15) and top beams (2).



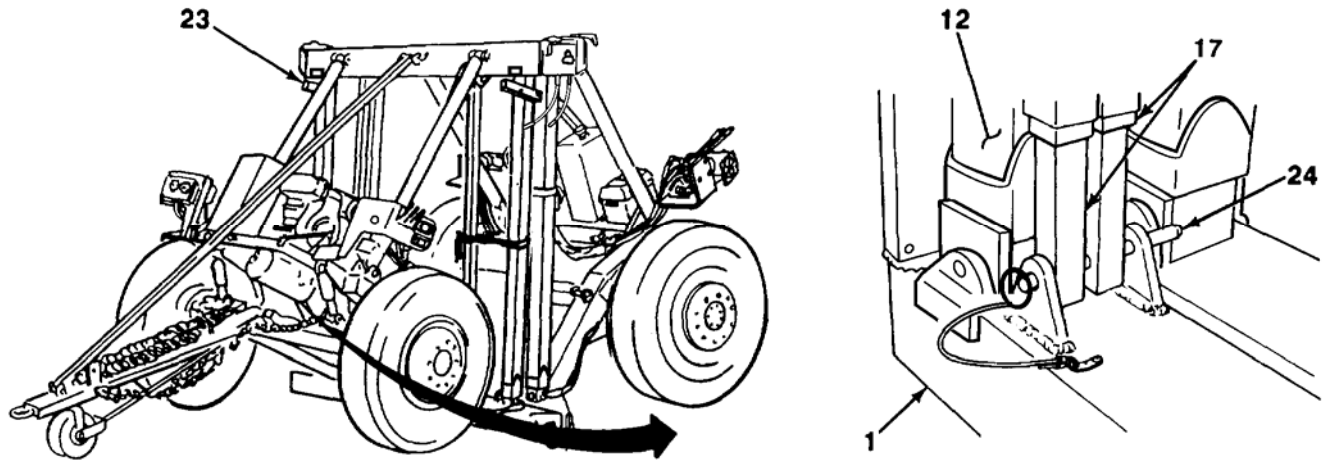
DS1022-120

t. Remove rest pin (19) from fourth hole (18) at end of each smaller brace (22). Install rest pin in hole (20) at end of each larger brace (21).



**2-10. ATTACHING FRONT AND REAR DOLLIES TO EACH OTHER (Con't).**

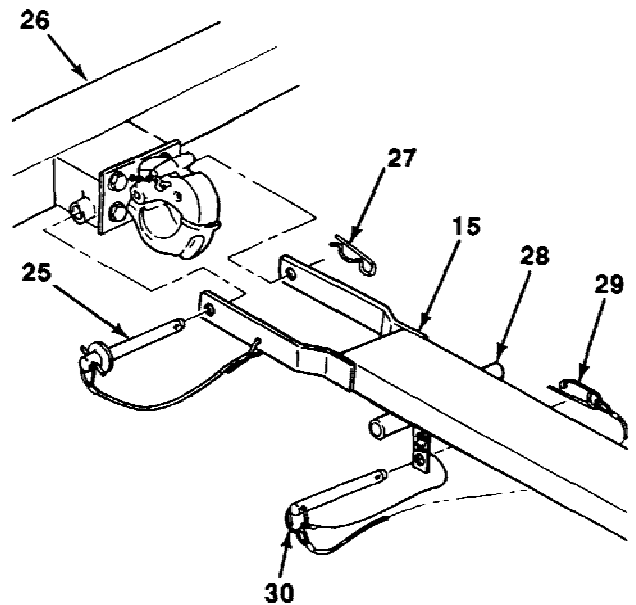
u. Stow two telescopic braces (17) on bottom beam (1) of front dolly with detent pin (24). Heads of rest pins (19) positioned in step t should be facing each other. Secure larger brace end of telescopic braces with stowage strap. Locate stowage strap around telescopic braces and top beam vertical tube (12) approximately 1 foot (30 Cm) **BELOW** hanger bracket (23).



DS1022-121

v. Stow handle (28) under rear drawbar (15) and secure with hitch pin (30) and safety pin (29).

w. Remove lockpin (27), pin (25), and rear drawbar (15) from rear axle (26).



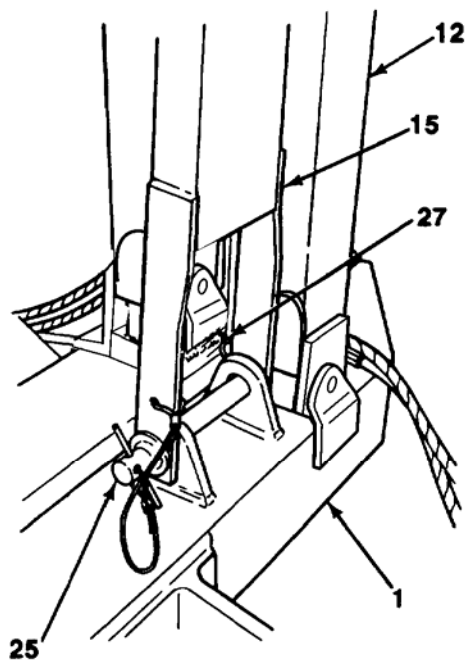
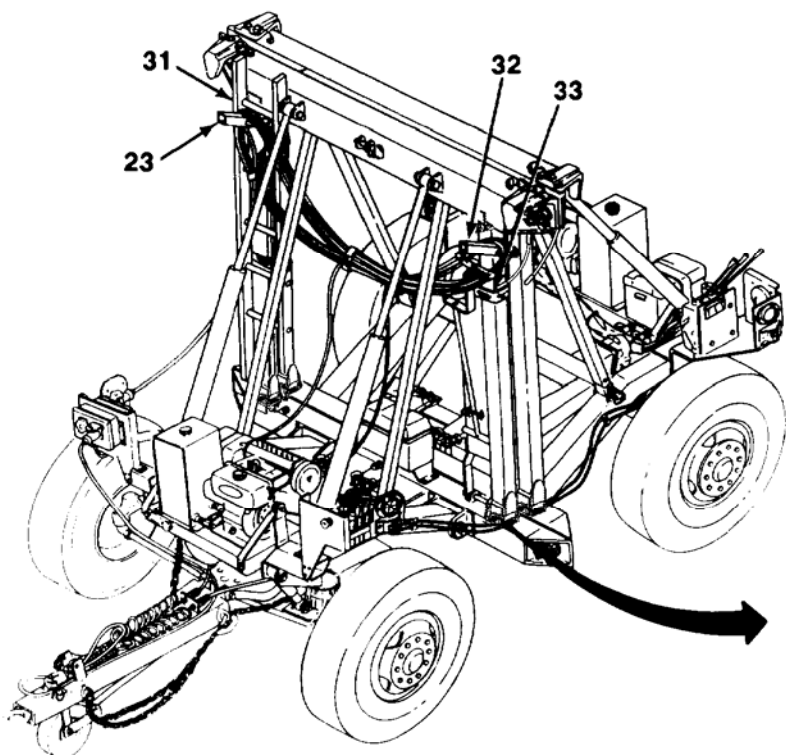
---

**2-10. ATTACHING FRONT AND REAR DOLLIES TO EACH OTHER (Con't).**

---

x. Stow rear drawbar (15) on bottom beam (1) of front dolly with pin (25) and lockpin (27). Secure rear drawbar with stowage strap (33). Locate stowage strap around rear drawbar and top beam vertical tube (12) approximately 1 foot (30 cm) **BELOW** hanger bracket (32).

y. Hang ladder (31) on hanger bracket (23) and secure with two stowage straps. Locate one strap around bottom rung of ladder and top beam vertical tube (12). Locate other strap around second rung from top of ladder and top beam vertical tube.



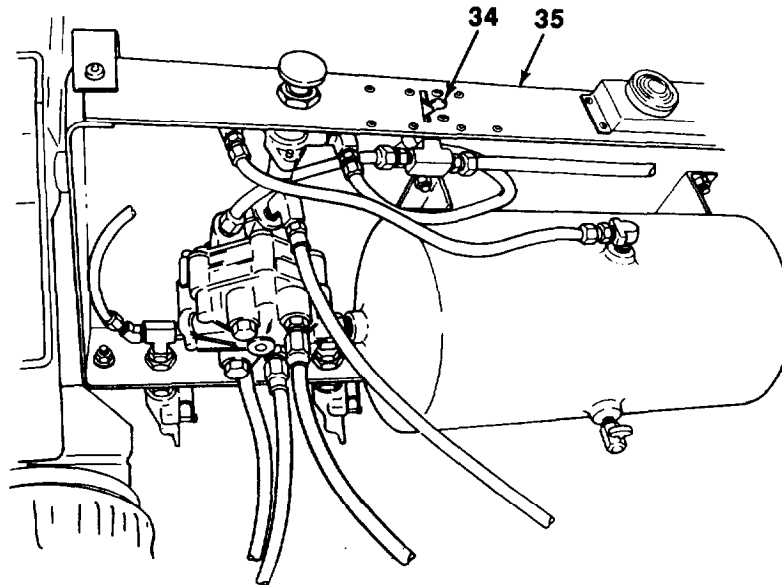
DS1022-122

---

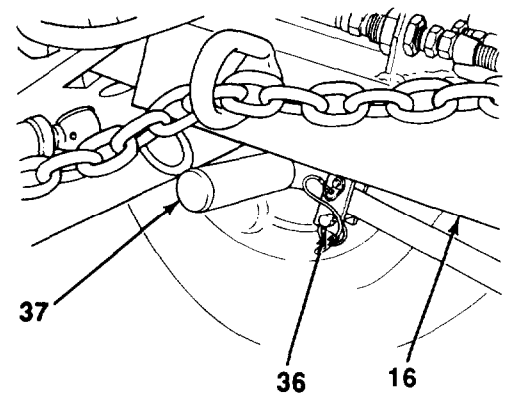
**2-10. ATTACHING FRONT AND REAR DOLLIES TO EACH OTHER (Con't).**

---

Apply parking brakes on rear dolly by turning parking brake lever (34) on pivoting tray (35) to ON position.



aa. Stow handle (37) under front drawbar (16) and secure with hitch pin (36) and safety pin.



---

**2-11. RAISING DOLLY SET WITH OR WITHOUT SHELTER AND COUPLING TO TOWING VEHICLE.**

---

**WARNING**

- All personnel must use caution when standing near dolly set, shelter (if present), and towing vehicle during raising and coupling operations. Failure to follow this warning may cause serious Injury or death to personnel.
- Use extreme caution when using ladder. Have an assistant hold ladder to ensure that it is stable. Failure to follow this warning may cause serious injury to personnel.

**CAUTION**

Ensure that all electrical and air connections are secure, and lines are not kinked or dragging on the ground. Failure to follow this caution may result in damage to equipment.

**NOTE**

- Procedures to raise dolly set, with or without shelter, and couple to towing vehicle are similar. Differences will be identified as they occur.
- If raising dolly set without shelter, perform steps a through c.
  - a. Connect one end of each intradolly air hose (7) to service (blue) and emergency (red) gladhands (4 and 8) on front dolly pivoting tray (9). Coil extra length of intradolly air hoses between two hanger brackets (11). Connect other end of each intradolly air hose to service (blue) and emergency (red) gladhands on rear dolly pivoting tray (10).

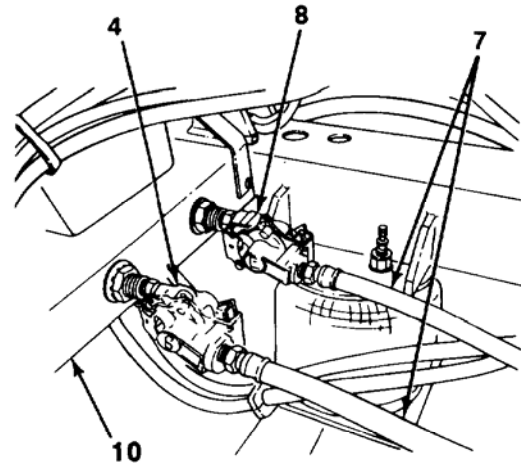
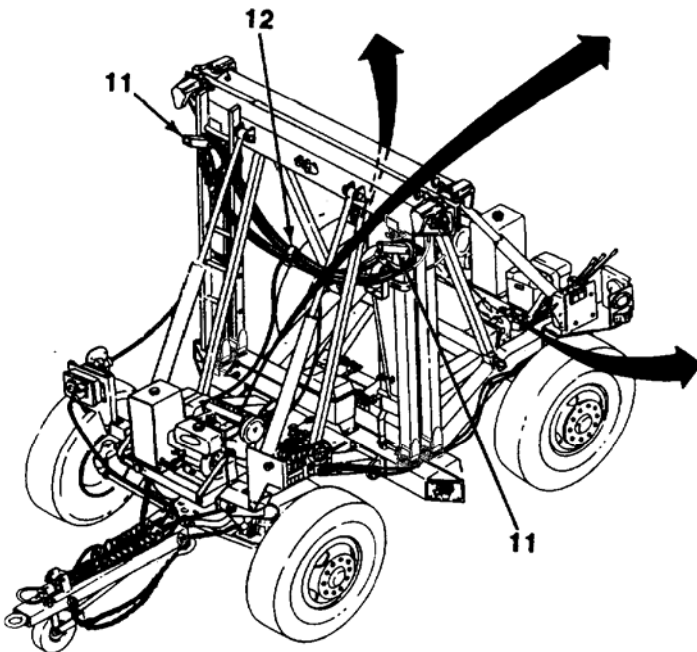
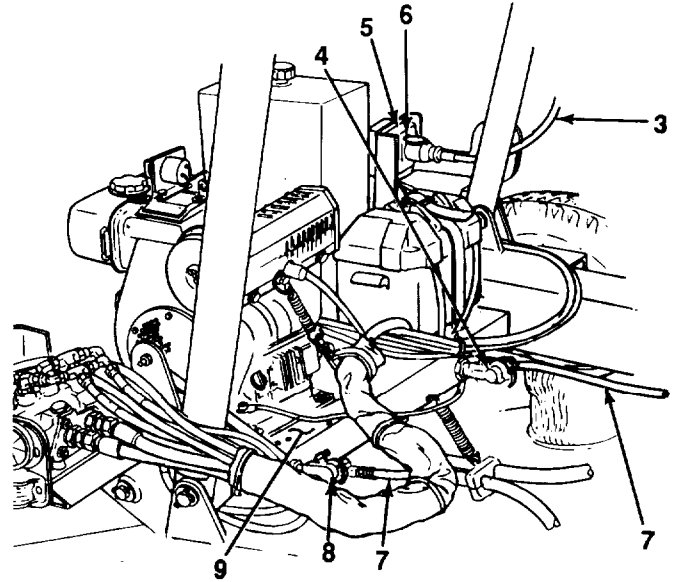
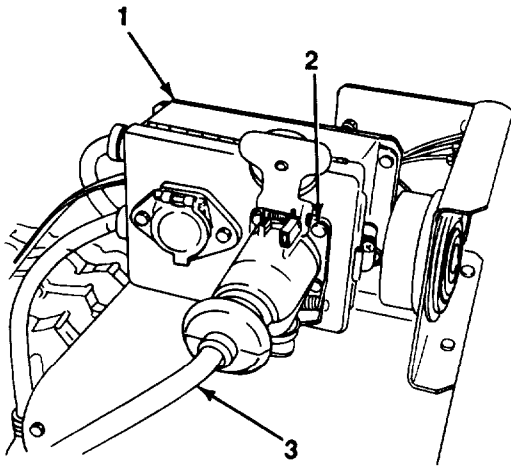
**NOTE**

If raising a dolly set in preparation for tandem towing, skip step b.

- b. Connect intradolly cable (3) between 24-volt receptacle connector (6) at forward junction box (5) and 24-volt receptacle connector (2) at rear junction box (1). Coil extra length of intradolly cable between hanger brackets (11).
- c. Secure intradolly air hoses (7) and intradolly cable (3) if present, with two stowage straps (12).



2-11. RAISING DOLLY SET WITH OR WITHOUT SHELTER AND COUPLING TO TOWING VEHICLE (Con't).



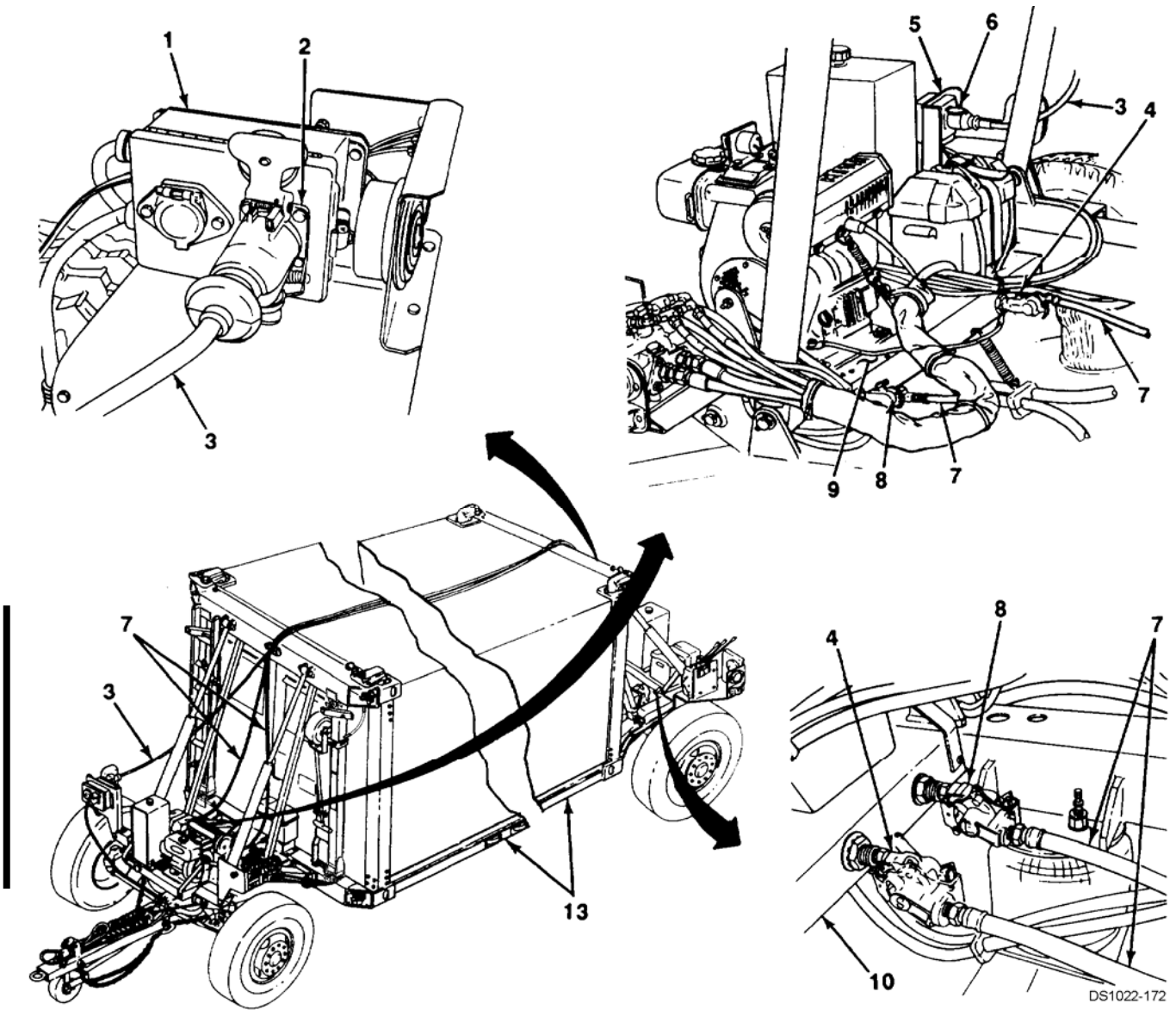
DS1022-123

**2-11. RAISING DOLLY SET WITH OR WITHOUT SHELTER AND COUPLING TO TOWING VEHICLE (Con't).**

**NOTE**

**If raising dolly set with shelter, perform steps d through g.**

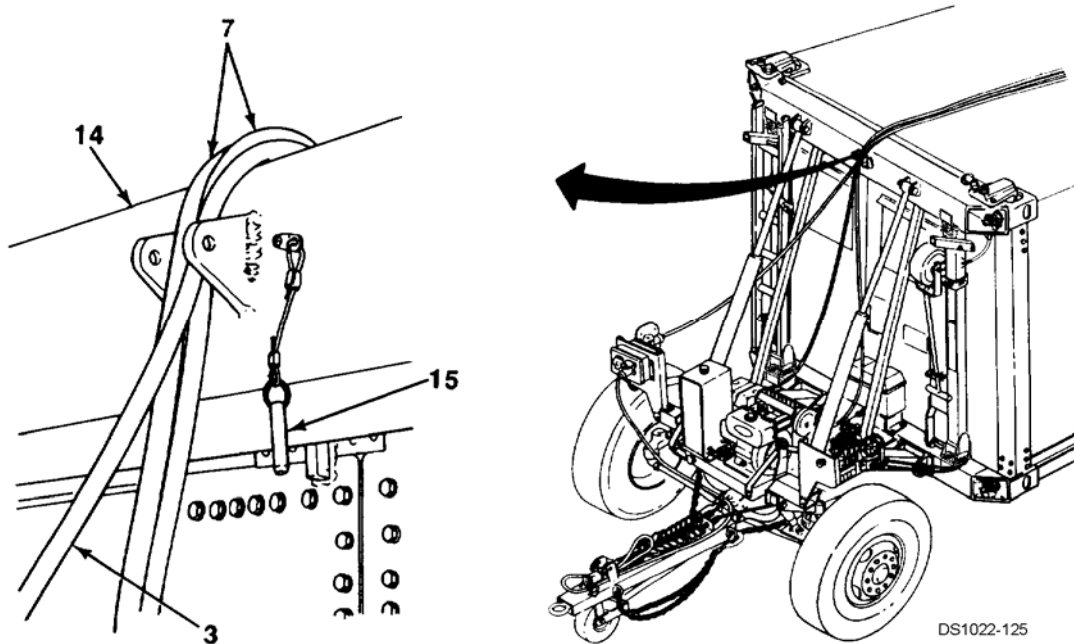
- d. Route intradolly air hoses (7) and intradolly cable (3) over top of shelter (13) on its centerline.
- e. Connect one end of each intradolly air hose (7) to service (blue) and emergency (red) gladhands (4 and 8) on front dolly pivoting tray (9). Connect other end of each intradolly air hose to service (blue) and emergency (red) gladhands on rear dolly pivoting tray (10).
- f. Connect intradolly cable (3) between 24-volt receptacle connector (6) at forward junction box (5) and 24-volt receptacle connector (2) at rear junction box (1).



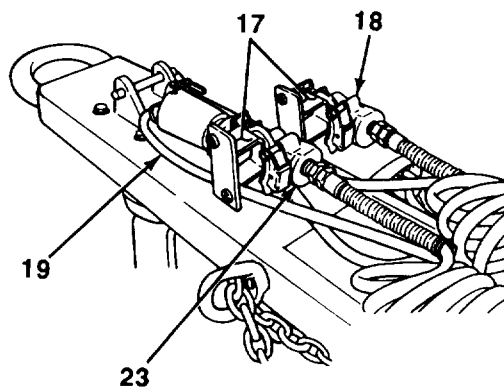
DS1022-172

**2-11. RAISING DOLLY SET WITH OR WITHOUT SHELTER AND COUPLING TO TOWING VEHICLE (Con't).**

g. At front and rear, secure intradolly air hoses (7) and intradolly cable (3) under telescopic brace detent pin (15) at midpoint of top beam (14).



h. Remove intervehicular gladhands (18 and 23) from dummy couplings (17). Connect intervehicular service (blue) gladhand (18) to towing vehicle service gladhand. Connect intervehicular emergency (red) gladhand (23) to towing vehicle emergency gladhand. Open towing vehicle air valves.

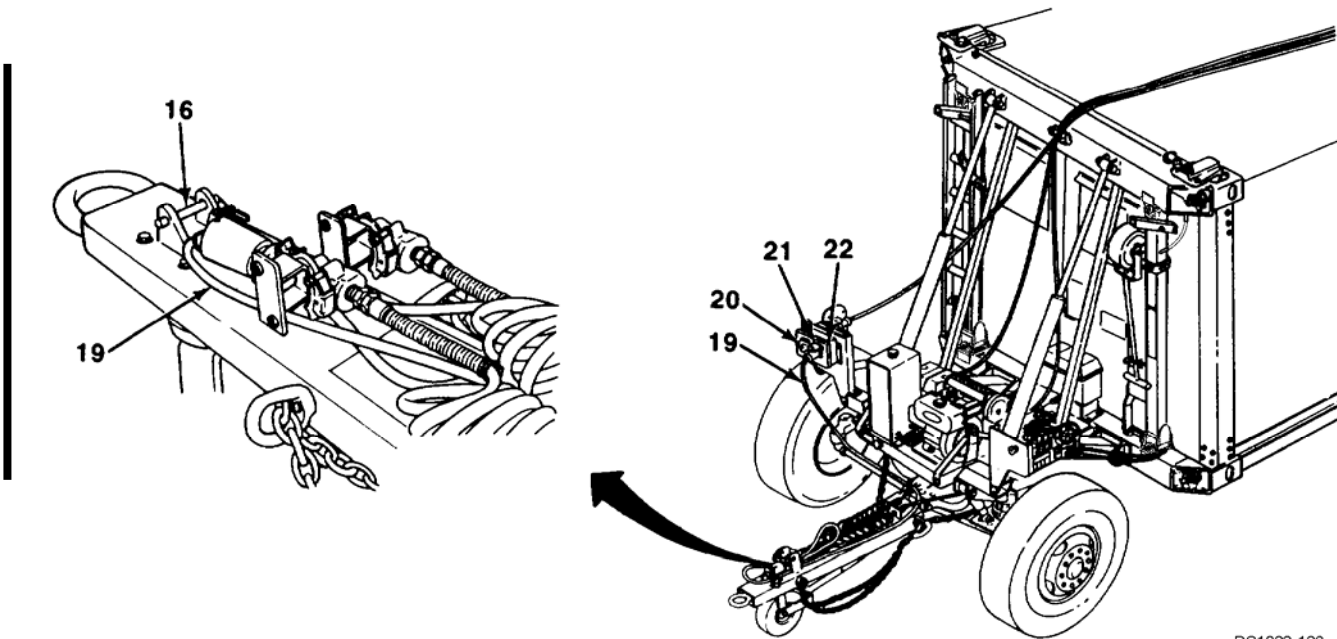


**2-11. RAISING DOLLY SET WITH OR WITHOUT SHELTER AND COUPLING TO TOWING VEHICLE (Con't).**

**NOTE**

- A 12-volt or 24-volt intervehicular cable may be used depending on towing vehicle's electrical system 12-volt intervehicular cable is connected to 12-volt receptacle connector (20) of signal conditioning box (22). 24-volt intervehicular cable is connected to 24-volt receptacle connector (21). This task shows a 24-volt intervehicular cable in use.
- If raising a rear dolly set in preparation for tandem towing, skip Step i.

- i. Connect intervehicular cable (19) to towing vehicle receptacle connector. Secure intervehicular cable under detent pin (16).
- j. Inflate air bags (see paragraph 2-22).



DS1022-126

**NOTE**

**If operating on uneven terrain, refer to paragraph 2-32 for instructions on locking the axle-to-pivot axle bracket coupling.**

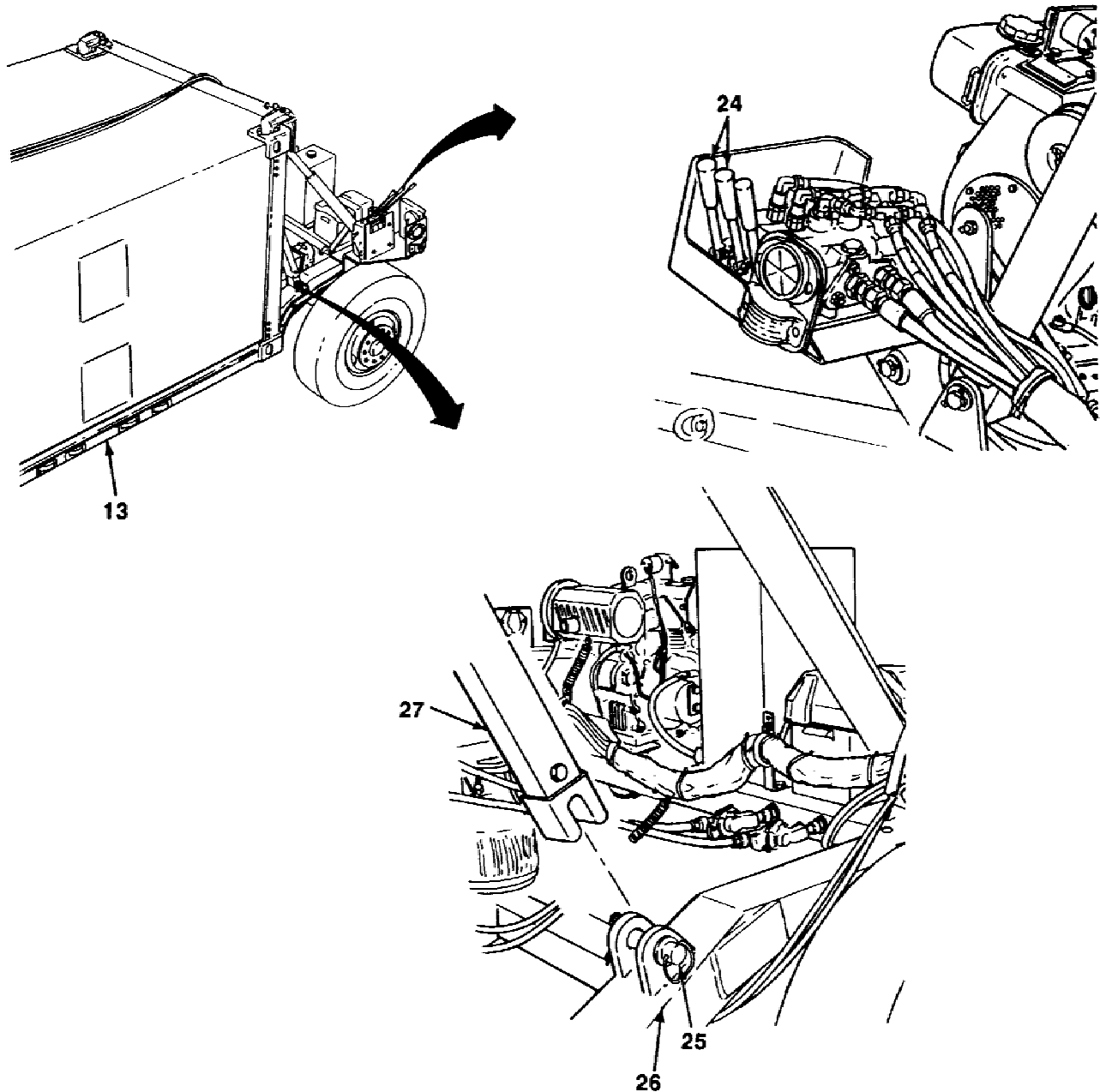
- k. At front and rear, pull down on two lift cylinder levers (24) to raise dolly set with or without shelter (13) off the ground to a sufficient height to allow engagement of two transportation lockouts (27) to suspension links (26).

---

**2-11. RAISING DOLLY SET WITH OR WITHOUT SHELTER AND COUPLING TO TOWING VEHICLE (Con't).**

---

- I. At front and rear, engage two transportation lockouts (27) on hitch pins (25) to suspension links (26).
- m. Shut down engine on front and rear dollies (see paragraph 2-20).



---

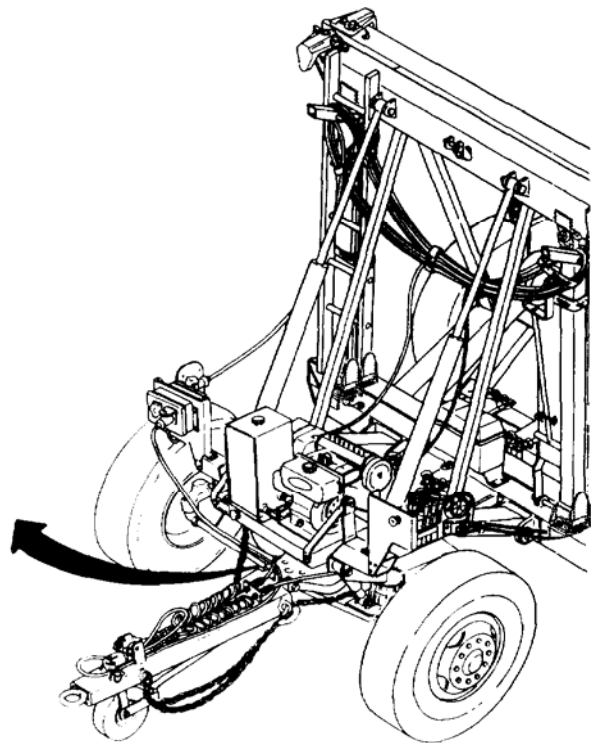
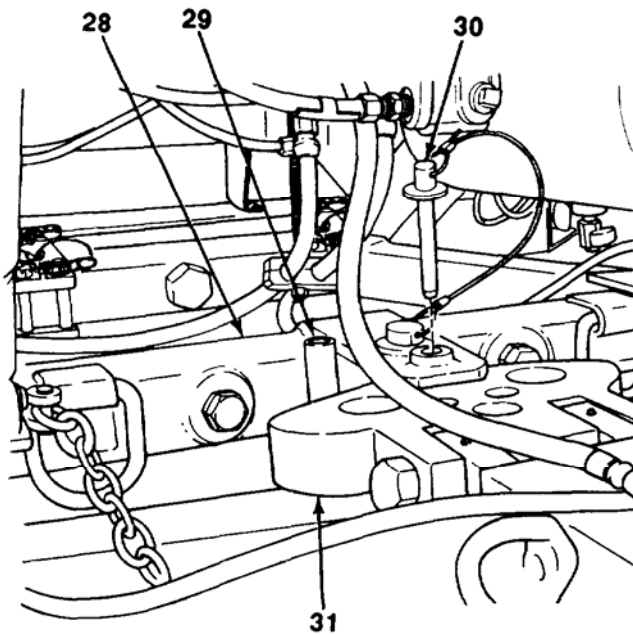
2-11. RAISING DOLLY SET WITH OR WITHOUT SHELTER AND COUPLING TO TOWING VEHICLE (Con't).

---

**WARNING**

Steering locking pin **MUST** be removed from front axle and steering link before dolly set is towed in a four-wheel configuration. Failure to unlock steering will damage steering linkage and may result in an accident.

- n. Remove steering locking pin (30) from front axle (28) and steering link (31). Stow steering locking pin in stowage tube (29) on front axle.



DS1022-127

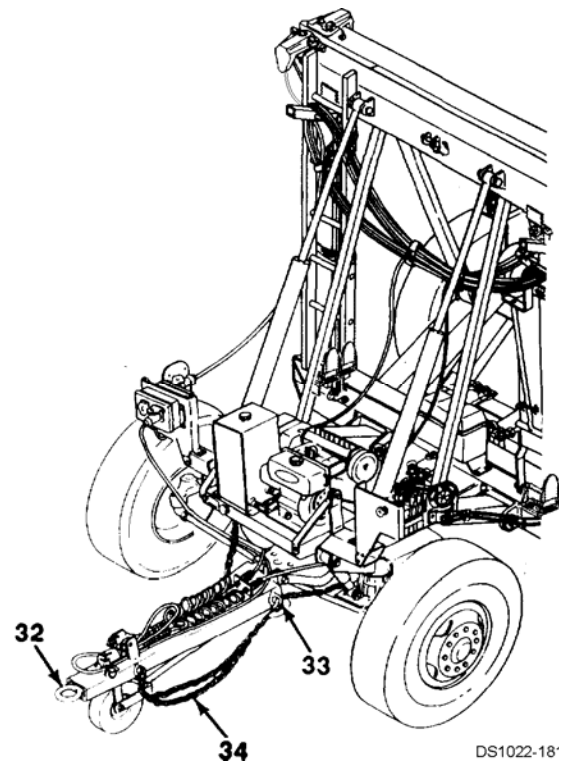
**2-11. RAISING DOLLY SET WITH OR WITHOUT SHELTER AND COUPLING TO TOWING VEHICLE (Con't).**

o. Remove towing vehicle safety pin and open pintle assembly. Install lunette (32) in towing vehicle pintle assembly. Close pintle assembly and install safety pin.

**NOTE**

**If raising a rear dolly set in preparation for tandem towing, safety chains should be installed on axle D-rings at rear of front dolly set.**

p. Remove safety chains (34) from stowage on rearmost eyebolts (33). Install safety chains on rear of towing vehicle.

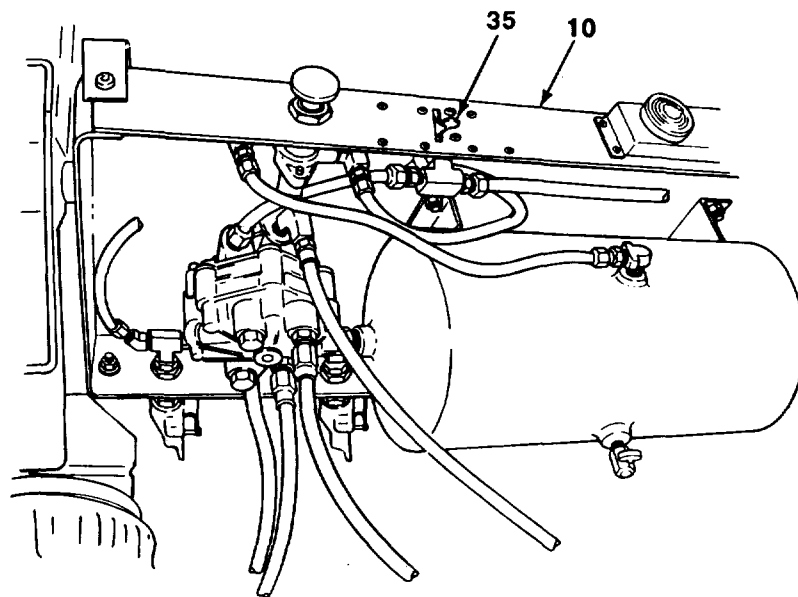


DS1022-18'

**NOTE**

**If raising a rear dolly set in preparation for tandem towing, skip step q.**

q. Release parking brakes on rear dolly by turning parking brake lever (35) on pivoting tray (10) to OFF position.



---

## 2-11. RAISING DOLLY SET WITH OR WITHOUT SHELTER AND COUPLING TO TOWING VEHICLE (Con't).

---

r. Deflate all air bags until top portion of each shock absorber reaches level of ride height indicator ring (see paragraph 2-22).

### NOTE

**If raising a rear dolly set in preparation for tandem towing, skip remaining steps in task.**

s. Using towing vehicle, pull dolly set, with or without shelter, slightly forward and check operation of service brakes (see towing vehicle Operator's Manual).

### NOTE

- If towing vehicle has a 12-volt system, blackout stoplight-taillights on rear dolly will NOT be functioning.
- If raising a front dolly set in preparation for tandem towing, lights on rear dolly will NOT be functioning.

t. Check operation of lights (see towing vehicle Operator's Manual).

---

## 2-12. ATTACHING FRONT AND REAR DOLLIES TO SHELTER (SHELTER ON GROUND) (SIDE LIFT OPERATION).

---

**WARNING**

- All personnel must use caution when standing near front and rear dollies and shelter during attaching operations. Failure to follow this warning may cause serious injury or death to personnel.
- Front axle steering locking pin must ALWAYS be installed for side lift operation. Failure to follow this warning may cause front dolly to overturn, resulting in serious injury or death to personnel.
- Use extreme caution when using ladder. Have an assistant hold ladder to ensure that it is stable. Failure to follow this warning may cause serious injury to personnel.

**CAUTION**

This operation CANNOT be performed unless Direct Support Maintenance has installed side lift kit on dolly set.

### NOTE

**Component parts of side lift kit are stowed in storage box of front dolly.**

a. Place each dolly half in maneuvering position (see paragraph 2-21 b).



---

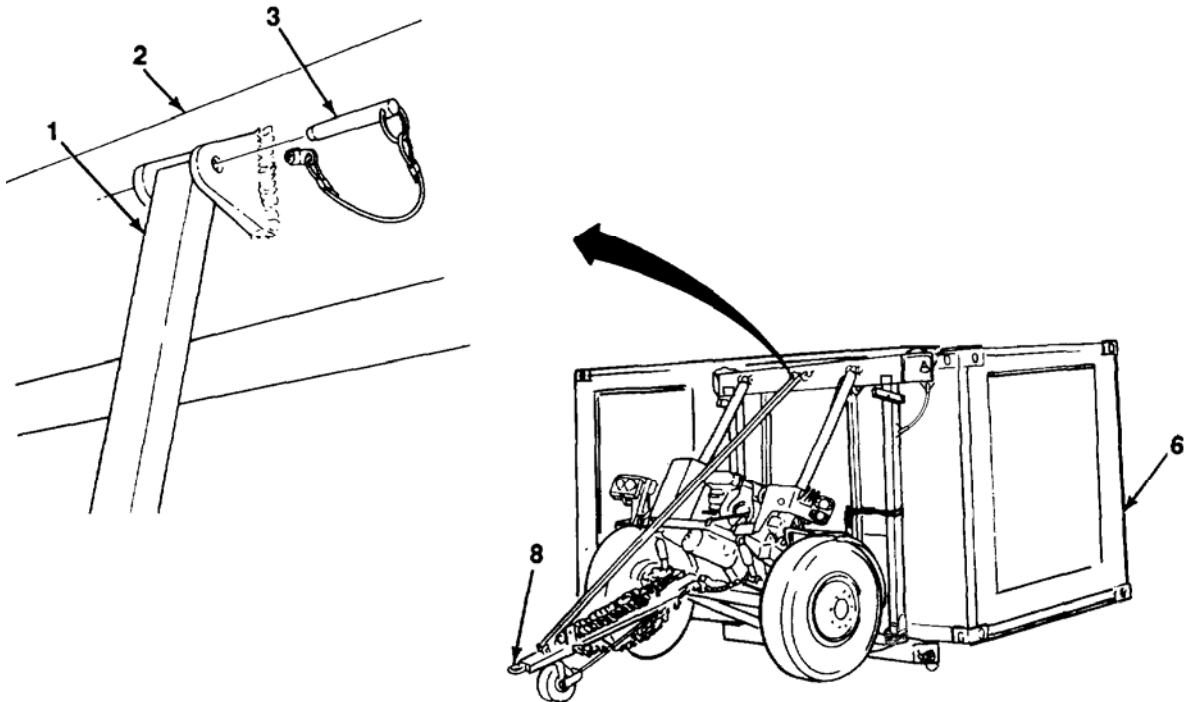
**2-12. ATTACHING FRONT AND REAR DOLLIES TO SHELTER (SHELTER ON GROUND) (SIDE LIFT OPERATION) (Con't).**

---

**WARNING**

**While in maneuvering position, DO NOT operate positioning cylinders lever. Failure to follow this warning may cause bottom beam to lower to the ground, causing serious injury to personnel.**

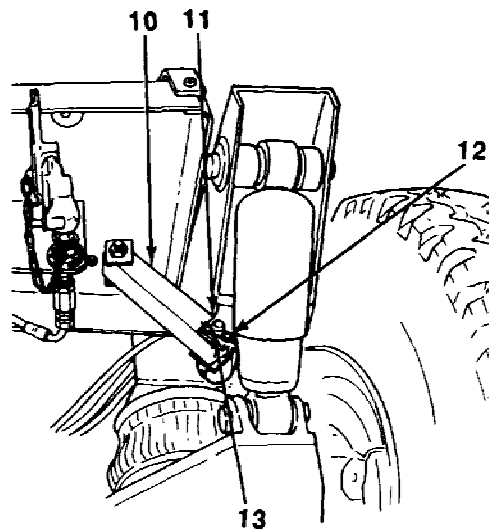
- b. Move each dolly half into position at centerline of side of shelter (6). Place within 6 in. (15 cm) of shelter.
- c. Remove each dolly half from maneuvering position (see paragraph 2-21c).
- d. At front and rear, remove two detent pins (3) and telescopic brace (1) from top beam (2) and drawbar (8). Set telescopic braces aside.



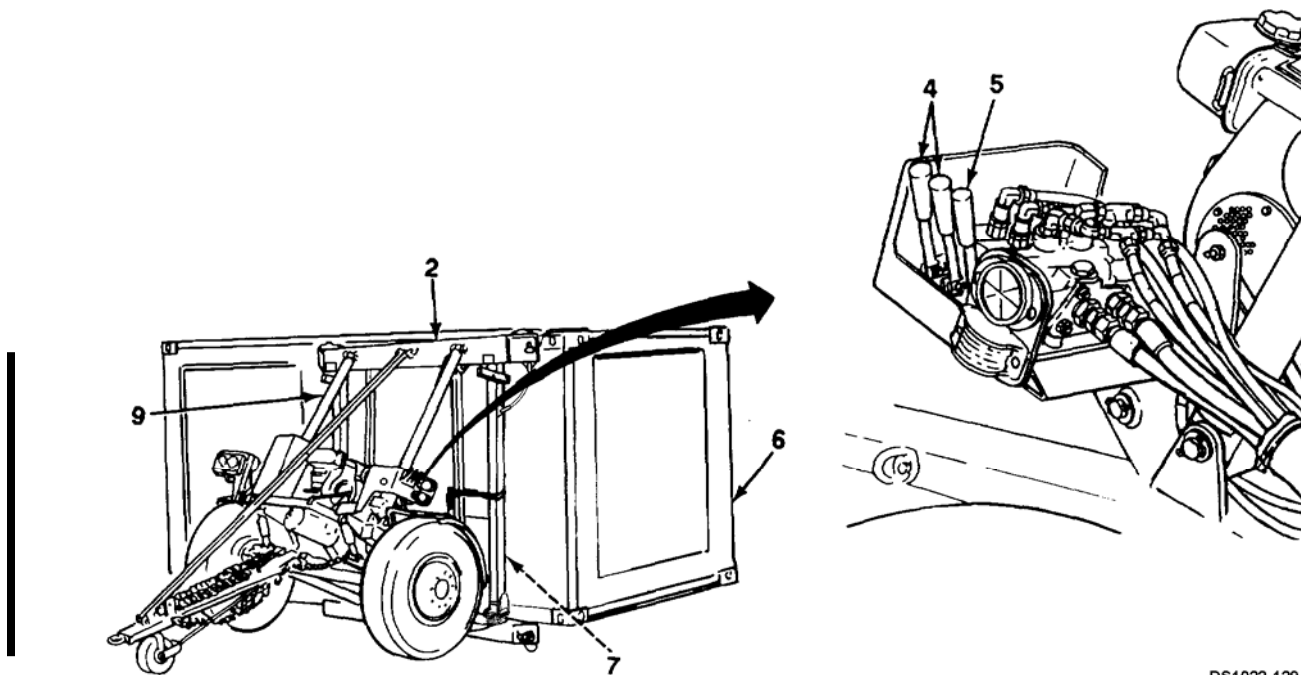
DS1022-128

**2-12. ATTACHING FRONT AND REAR DOLLIES TO SHELTER (SHELTER ON GROUND) (SIDE LIFT OPERATION) (Con't).**

e. At front and rear, remove safety pin (12) and hitch pin (13) and unlock pivoting tray lockout brace (10) from lower bracket (11).



f. At front and rear, pull down on two lift cylinder levers (4) and positioning cylinders lever (5) to extend lift and positioning cylinders (9 and 7). Stop when top beam (2) is positioned **ABOVE** shelter (6) (see paragraph 2-21).



DS1022-129

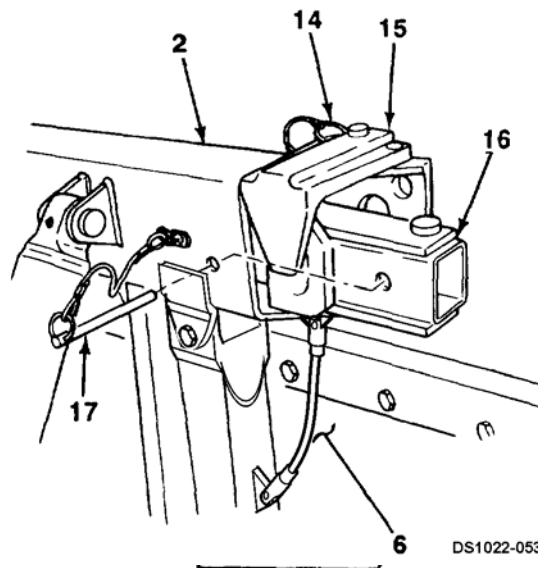
---

**2-12. ATTACHING FRONT AND REAR DOLLIES TO SHELTER (SHELTER ON GROUND) (SIDE LIFT OPERATION) (Con't).**


---

g. At front and rear top beams (2), remove two detent pins (14) and rotate top hooks (15) 180° away from shelter engagement position. Install detent pins.

h. Remove two detent pins for crossbrace assemblies (16) from storage box on front dolly.



**WARNING**

- Use extreme caution when climbing and working on top of shelter during side lift operations. Ensure that top of shelter is free of ice or debris which could cause slips and falls. When working with twist locks from on top of shelter, maintain a three-point contact with shelter as much as possible. When on top of shelter, always be aware of where other personnel and tools are located to prevent accidental bumps and trips. Failure to follow this warning may cause serious injury to personnel.
  - All personnel standing on ground must stand clear when crossbrace assemblies are being removed from top beam. If a crossbrace assembly is dropped, serious injury or death to personnel could result.
- i. At front and rear, remove detent pin (17) and crossbrace assembly (16) from stowage in top beam (2). Rest crossbrace assemblies on top of shelter (6).

## 2-12. ATTACHING FRONT AND REAR DOLLIES TO SHELTER (SHELTER ON GROUND) (SIDE LIFT OPERATION) (Con't).

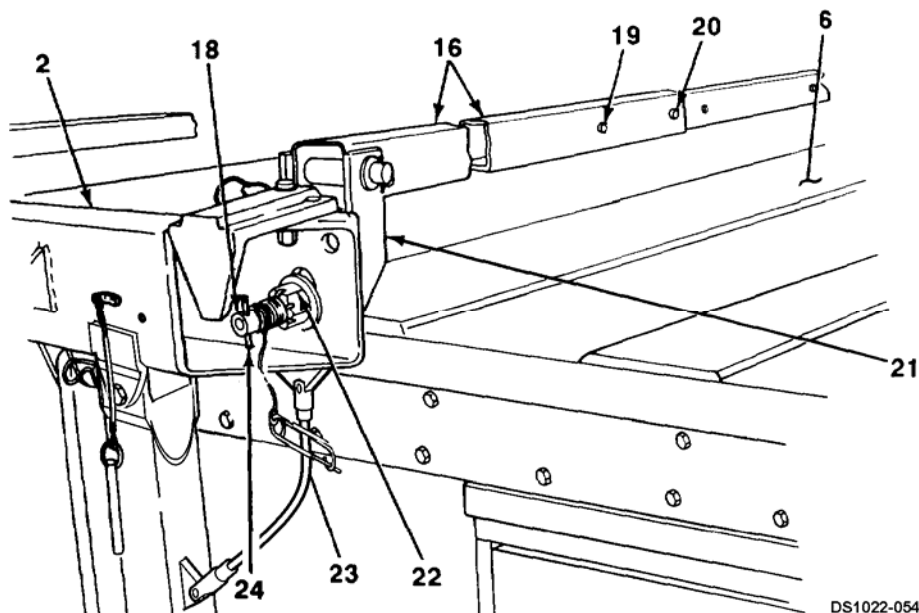
j. Remove detent pin (19) securing each crossbrace assembly (16) in retracted position. Extend crossbrace assembly until two holes align. Install detent pin (19) and detent pin (20) that was removed from storage box.

k. Extend crossbrace assemblies (16) over top of shelter (6). Crossbrace bracket (21) at each end of crossbrace assembly should be positioned flush against top beam (2). Operate hydraulic control valve as required to achieve proper alignment (see paragraph 2-21).

**WARNING**

**Use extreme caution when installing twist locks. Keep hands and/or feet clear of top hooks, top and bottom beams, and from between beams and shelter. Failure to follow this warning may cause serious injury to personnel.**

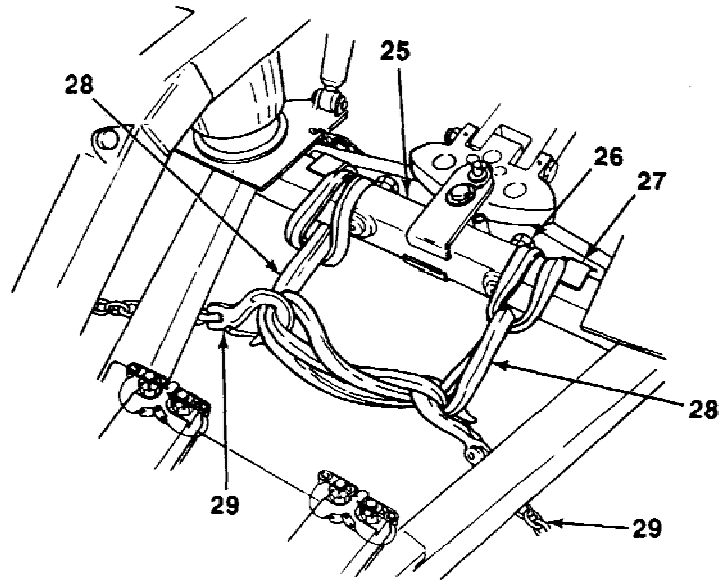
l. At front and rear, install two twist locks (18) through slots in top beam (2). Rotate twist locks 90° and insert through crossbrace brackets (21). Rotate twist locks 90° again. Locate twist locks so that they are against top of slots in top beam. Use twist lock wrench (Item 3, Appendix D) to fully tighten nuts (22). Ensure that twist lock pins (24) are vertical. Safety pins (23) do NOT need to be installed through twist locks.



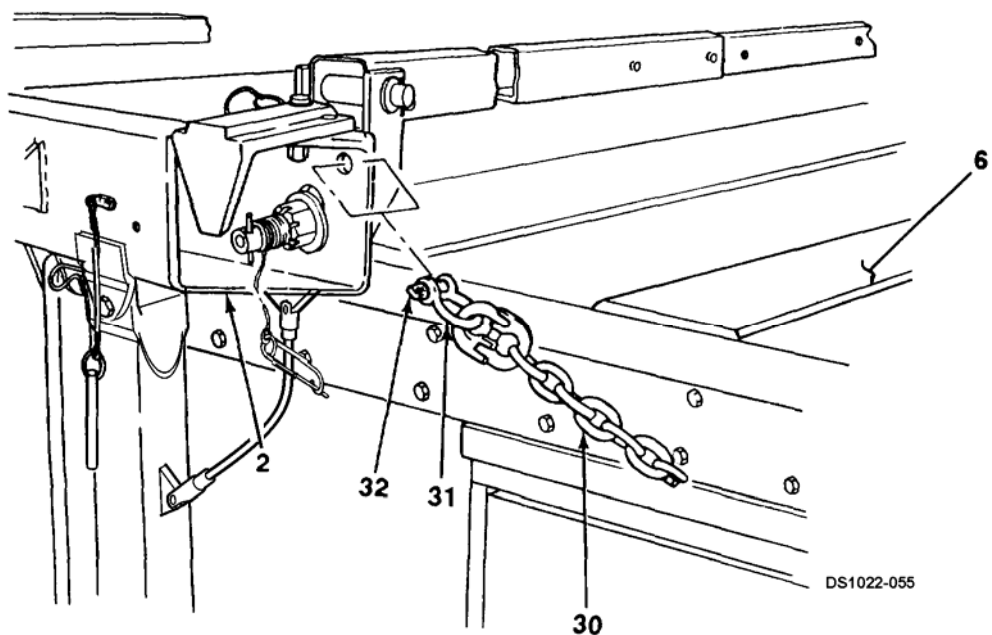
m. Loop and secure two slings (28) to each axle (25), as illustrated. On front dolly, position slings between tie-down D-rings (27) and steering stops (26). On rear dolly, position slings between tie-down D-rings and pintle assembly approximately 10 in. (25.4 cm) off centerline to each side.

n. Lay out chain assembly at each corner of shelter (6).

**2-12. ATTACHING FRONT AND REAR DOLLIES TO SHELTER (SHELTER ON GROUND) (SIDE LIFT OPERATION) (Con't).**



- o. Install lifting chain (30) to each end of top beam (2) with shackle (31) and pin (32) through hole.
- p. Stretch out and cross slings (28) in a U-shaped pattern as shown. Hook end of each axle chain (29) through BOTH strands of same side sling and looped end of opposite side sling, as illustrated. Ensure that axle chains are routed UNDER axle (25).



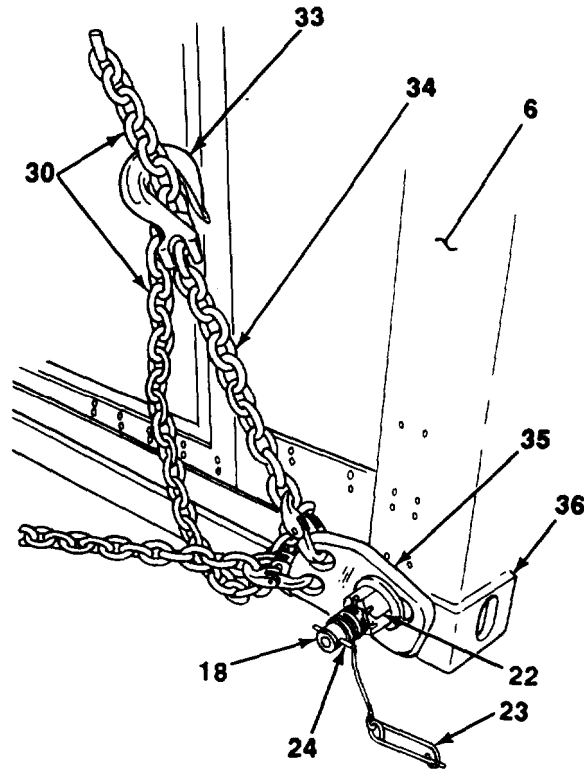
**2-12. ATTACHING FRONT AND REAR DOLLIES TO SHELTER (SHELTER ON GROUND) (SIDE LIFT OPERATION) (Con't).**

q. Install adapter (35) to each bottom corner block (36) of shelter (6) with twist lock (18). Adapter should be oriented at an approximate 45° angle, along axis of lifting chain (30). Rotate twist lock 90° and use twist lock wrench (Item 3, Appendix D) to fully tighten nut (22). Twist lock pin (24) must be horizontal. Safety pin (23) does NOT need to be installed through twist lock.

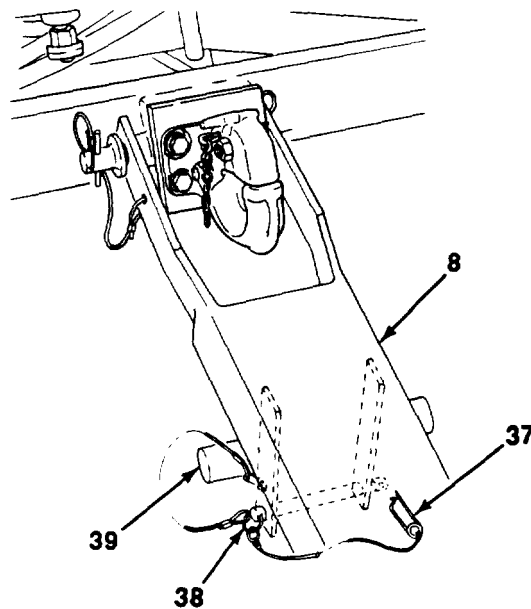
r. At each corner of shelter (6), take up slack in lifting chain (36) with hook (33) of take-up chain (34).

s. Inflate all air bags (see paragraph 2-22).

t. At front and rear, operate hydraulic control valve to put slight tension on lifting chains (30) (see paragraph 2-21). DO NOT lift shelter (6) off ground. Check tightness and orientation of all twist locks (18).



u. At front and rear, stow handle (39) under drawbar (8) with hitch pin (38) and safety pin (37).

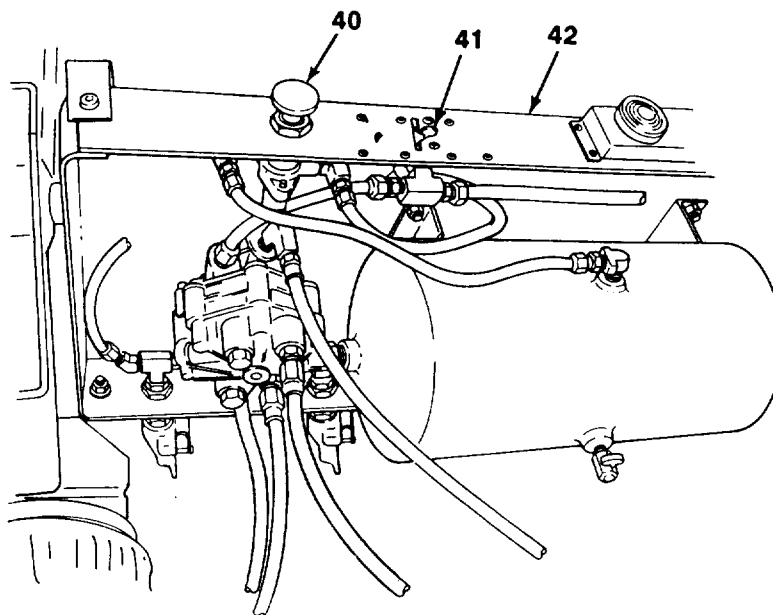


---

**2-12. ATTACHING FRONT AND REAR DOLLIES TO SHELTER (SHELTER ON GROUND) (SIDE LIFT OPERATION) (Con't).**

---

v. Apply brakes on rear dolly by pulling airbrake control knob (40). Parking brake lever (41) on pivoting tray (42) is in OFF position.



---

2-13. ATTACHING FRONT AND REAR DOLLIES TO SHELTER (SHELTER ON TRAILER) (SIDE LIFT OPERATION) (Con't).

---

**WARNING**

- All personnel must use caution when standing near front and rear dollies and shelter during attaching operations. Failure to follow this warning may cause serious injury or death to personnel.
- Front axle steering locking pin must ALWAYS be installed for side lift operation. Failure to follow this warning may cause front dolly to overturn, resulting in serious injury or death to personnel.
- Use extreme caution when using ladder. Have an assistant hold ladder to ensure that it is stable. Failure to follow this warning may cause serious injury to personnel.

**CAUTION**

This operation CANNOT be performed unless Direct Support Maintenance has installed side lift kit on dolly set.

**NOTE**

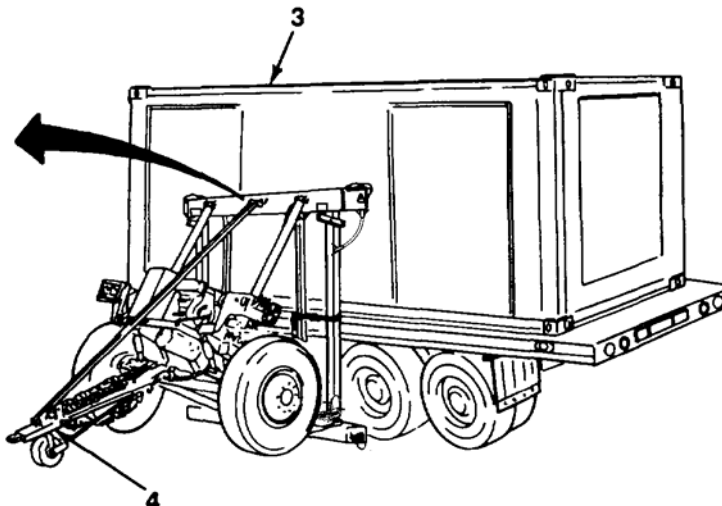
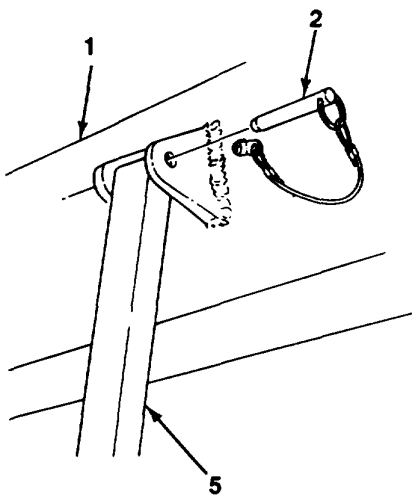
Component parts of side lift kit are stowed in storage box of front dolly.

- a. Place each dolly half in maneuvering position (see paragraph 2-21 b).

**WARNING**

While in maneuvering position, DO NOT operate positioning cylinders lever. Failure to follow this warning may cause bottom beam to lower to the ground, causing serious injury to personnel.

- b. Move each dolly half into position at centerline of side of shelter (3). Place within 6-in. (15 cm) of shelter.



DS1022-130

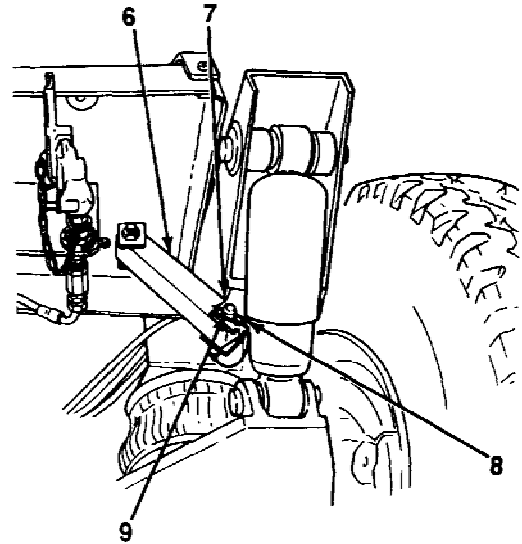


**2-13. ATTACHING FRONT AND REAR DOLLIES TO SHELTER (SHELTER ON TRAILER) (SIDE LIFT OPERATION) (Con't).**

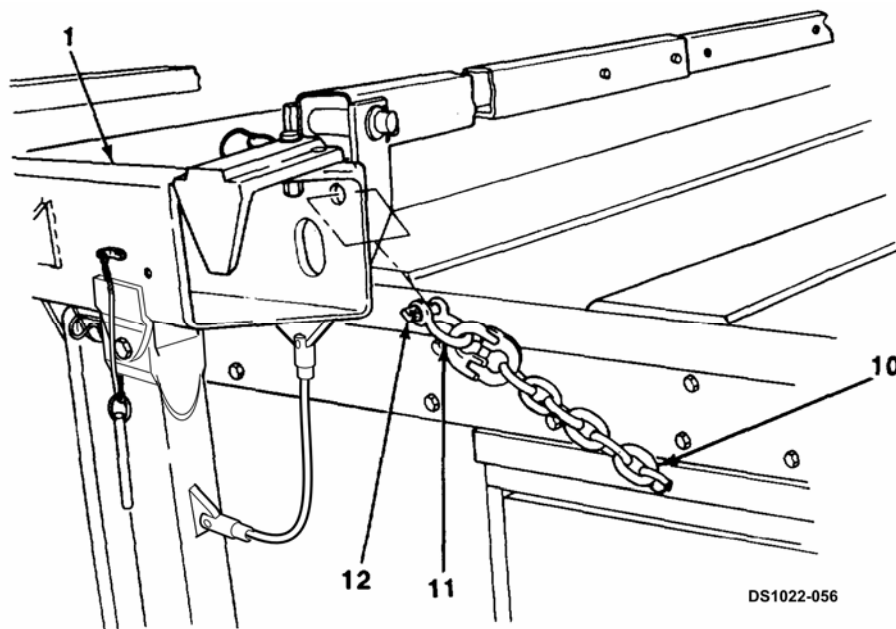
c. Remove each dolly half from maneuvering position (see paragraph 2-21 c).

d. At front and rear, remove two detent pins (2) and telescopic brace (5) from top beam (1) and drawbar (4). Set telescopic braces aside.

e. At front and rear, remove safety pin (8) and hitch pin (9) and unlock pivoting tray lockout brace (6) from lower bracket (7).



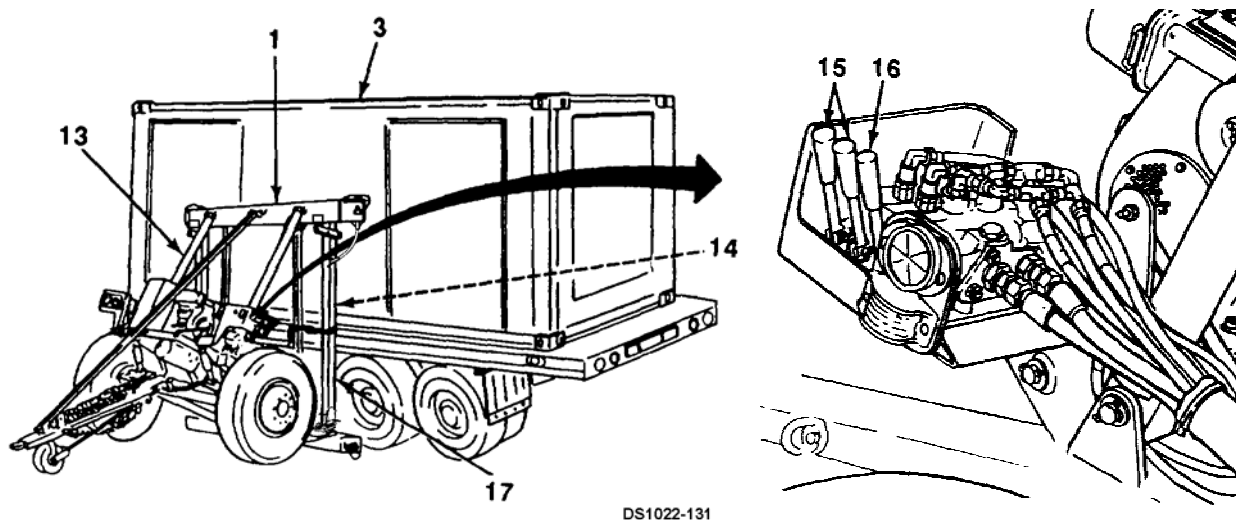
f. At front and rear, install lifting chain (10) to each end of top beam (1) with shackle (11) and pin (12) through hole.



**2-13. ATTACHING FRONT AND REAR DOLLIES TO SHELTER (SHELTER ON TRAILER) (SIDE LIFT OPERATION) (Con't).**

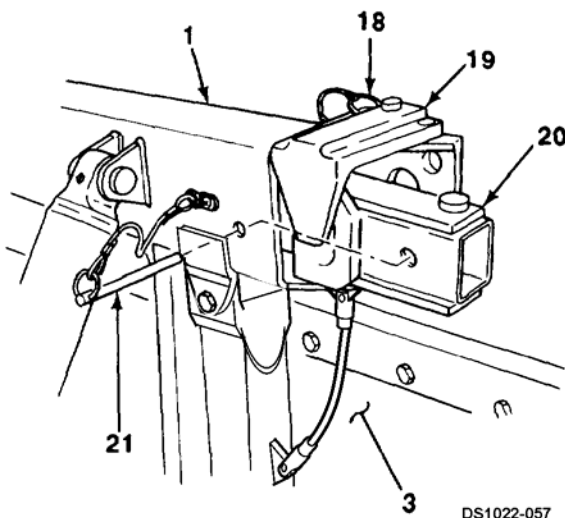
g. At front and rear, perform the following steps, maintaining top and bottom beam vertical tubes (17) vertical.

- (1) Pull down on two lift cylinder levers (15) to extend lift cylinders (13).
- (2) Pull down on positioning cylinders lever (16) to extend positioning cylinders (14).
- (3) Repeat steps g(1) and g(2) as required until top beam (1) is positioned ABOVE shelter (3) and top and bottom beam vertical tubes rest against shelter.



h. At front and rear top beams (1), remove two detent pins (18) and rotate top hooks (19) 180° away from shelter engagement position. Install detent pins.

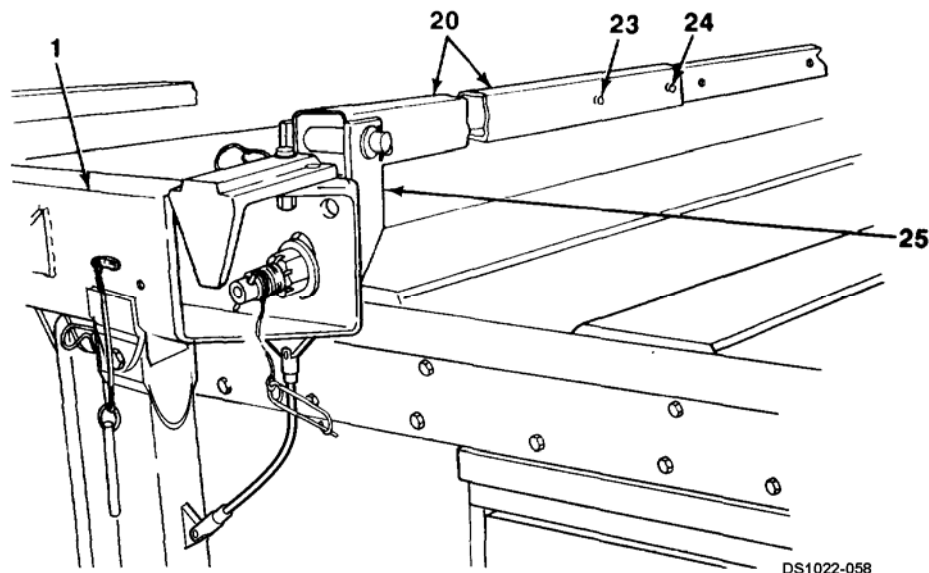
i. Remove two detent pins for crossbrace assemblies (20) from storage box on front dolly.



## 2-13. ATTACHING FRONT AND REAR DOLLIES TO SHELTER (SHELTER ON TRAILER) (SIDE LIFT OPERATION) (Con't).

### WARNING

- Use extreme caution when climbing and working on top of shelter during side lift operations. Ensure that top of shelter is free of ice or debris which could cause slips and falls. When working with twist locks from on top of shelter, maintain a three-point contact with shelter as much as possible. When on top of shelter, always be aware of where other personnel and tools are located to prevent accidental bumps and trips. Failure to follow this warning may cause serious injury to personnel.
  - All personnel standing on ground must stand clear when crossbrace assemblies are being removed from top beam. If a crossbrace assembly is dropped, serious injury or death to personnel could result.
- j. At front and rear, remove detent pin (21) and crossbrace assembly (20) from stowage in top beam (1). Rest crossbrace assemblies on top of shelter (3).
- k. Remove detent pin (23) securing each crossbrace assembly (20) in retracted position. Mend crossbrace assembly until two holes align. Install detent pin (23) and detent pin (24) that was removed from storage box.
- l. Extend crossbrace assemblies (20) over top of shelter (3). Crossbrace bracket (25) at each end of crossbrace assembly should be positioned flush against top beam (1). Operate hydraulic control valve as required to achieve proper alignment (see paragraph 2-21).

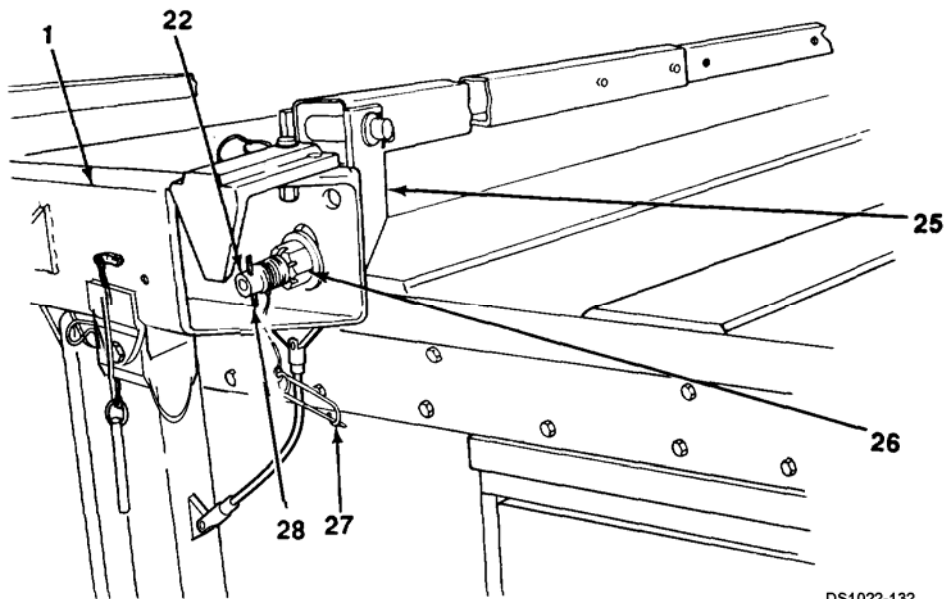


**2-13. ATTACHING FRONT AND REAR DOLLIES TO SHELTER (SHELTER ON TRAILER) (SIDE LIFT OPERATION) (Con't).**

**WARNING**

**Use extreme caution when installing twist locks. Keep hands and/or feet clear of top hooks, top and bottom beams, and from between beams and shelter. Failure to follow this warning may cause serious injury to personnel.**

m. At front and rear, install two twist locks (22) through slots in top beam (1). Rotate twist locks 90° and insert through crossbrace brackets (25). Rotate twist locks 90° again. Locate twist locks so that they are against top of slots in top beam. Use twist lock wrench (Item 3, Appendix D) to fully tighten nuts (26). Ensure that twist lock pins (28) are vertical. Safety pins (27) do NOT need to be installed through twist locks.



DS1022-132

n. Loop and secure two slings (32) to each axle (29) as illustrated. On front dolly, position slings between tie-down D-rings (31) and steering stops (30). On rear dolly, position slings between tie-down D-rings and pintle assembly approximately 10 in. (25.4 cm) off centerline to each side.

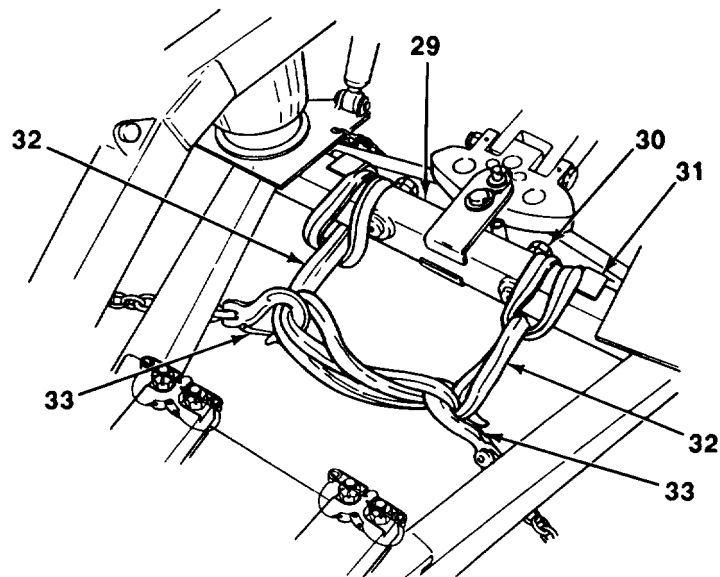
---

**2-13. ATTACHING FRONT AND REAR DOLLIES TO SHELTER (SHELTER ON TRAILER) (SIDE LIFT OPERATION) (Con't).**

---

o. Stretch out and cross slings (32) in a U-shaped pattern as shown. Hook end of each axle chain (33) through BOTH strands of same side sling and looped end of opposite side sling, as illustrated. Ensure that axle chains are routed UNDER axle (29).

p. Inflate all air bags (see paragraph 2-22).



**2-13. ATTACHING FRONT AND REAR DOLLIES TO SHELTER (SHELTER ON TRAILER) (SIDE LIFT OPERATION) (Con't).**

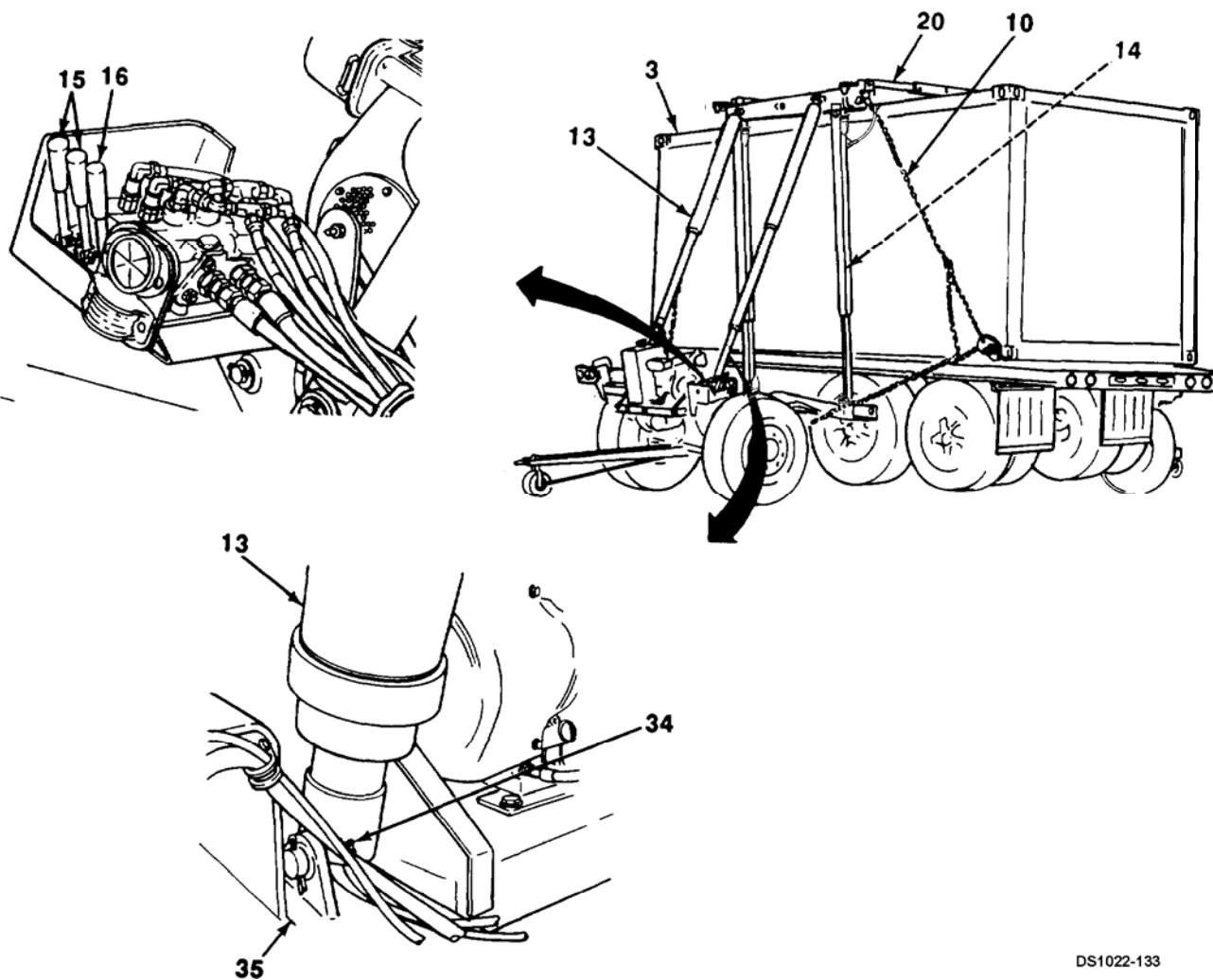
q. At front and rear, perform the following steps:

- (1) Push up on two lift cylinder levers (15) to lower crossbrace assemblies (20) onto top of shelter
- (3). Dolly set is now suspended by crossbrace assemblies.

**CAUTION**

**Use caution to ensure that lift cylinder grease fittings DO NOT contact suspension links and become damaged.**

- (2) Push up on positioning cylinders lever (16) to retract positioning cylinders (14). Stop when grease fitting (34) at base of each lift cylinder (13) is 1 in. (2.5 cm) above suspension link (35). This corresponds to an angle of approximately 30° between lift cylinder and suspension link.



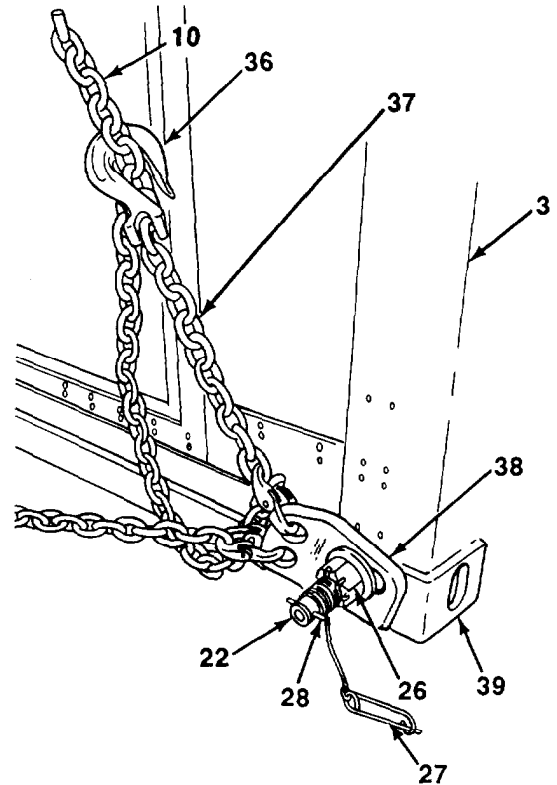
DS1022-133

**2-13. ATTACHING FRONT AND REAR DOLLIES TO SHELTER (SHELTER ON TRAILER) (SIDE LIFT OPERATION) (Con't).**

r. Install adapter (38) to each bottom corner block (39) of shelter (3) with twist lock (22). Adapter should be oriented at an approximate 45° angle, along axis of lifting chain (10). Rotate twist lock 90° and use twist lock wrench (Item 3, Appendix D) to fully tighten nut (26). Twist lock pin (28) must be horizontal. Safety pin (27) does NOT need to be installed through twist lock.

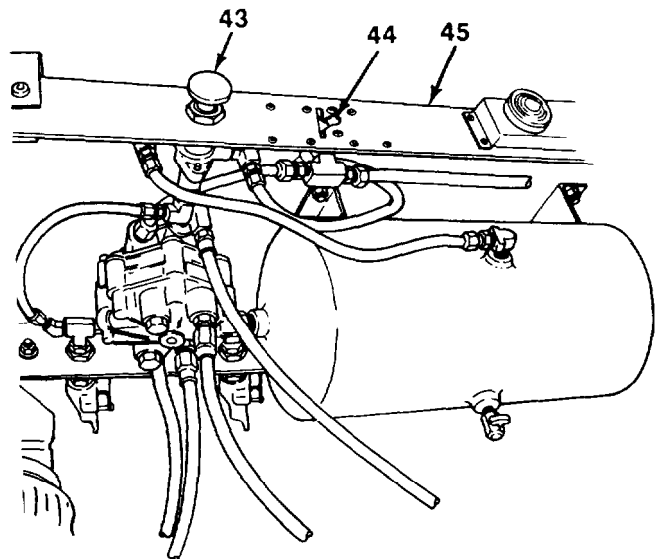
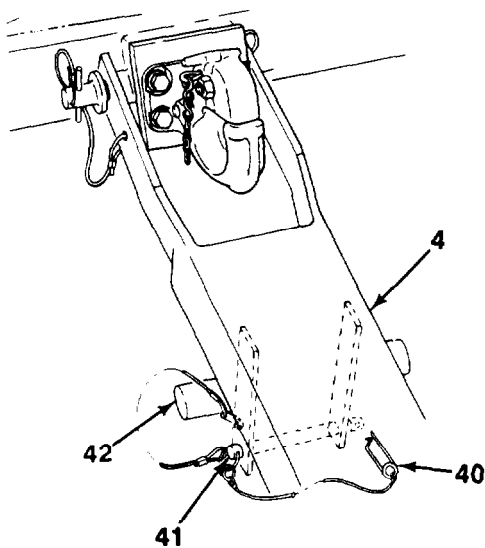
s. At each corner of shelter (3), take up slack in lifting chain (10) with hook (36) of take-up chain (37).

t. At front and rear, operate hydraulic control valve to put slight tension on lifting chains (10) (see paragraph 2-21). DO NOT lift shelter (3) off trailer. Check tightness and orientation of all twist locks (22).



u. At front and rear, stow handle (42) under drawbar (4) with hitch pin (41) and Safety pin (40).

v. Apply brakes on rear dolly by pulling airbrake control knob (43). Parking brake lever (44) on pivoting tray (45) is in OFF position.



---

**2-14. RAISING DOLLY SET WITH SHELTER AND LOADING ONTO TRAILER (SIDE LIFT OPERATION).**

---

**WARNING**

- All personnel must use caution when standing near dolly set, shelter, and trailer during raising operations. Failure to follow this warning may cause serious injury or death to personnel.
  - Front axle steering locking pin must ALWAYS be installed for side lift operation. Failure to follow this warning may cause front dolly to overturn, resulting In serious Injury or death to personnel.
- a. Attach front and rear dollies to shelter (see paragraph 2-12).
  - b. Locate a third person within view of each control valve operator. To ensure that shelter is raised evenly, third person should use the following hand signals using the index finger of each hand:
    - (1) Pointing UP - Extend lift cylinders.
    - (2) Pointing DOWN - Retract lift cylinders,
    - (3) Pointing horizontally OUTWARD - Extend positioning cylinders.
    - (4) Pointing horizontally INWARD - Retract positioning cylinders.
    - (5) Showing a FIST - Stop or hold.

**CAUTION**

- During raising operations, use caution to ensure that lift cylinder grease fittings DO NOT contact suspension links and become damaged.
- During raising operations, use caution to ensure that shelter is kept level. Failure to follow this caution may result in damage to shelter or dolly set,

**NOTE**

As shelter is raised, dolly halves will move away from shelter and axle chains will come under full tension; this is normal.

- c. At front and rear, perform the following steps:
  - (1) Pull down on two lift cylinder levers (8) to raise shelter (2). Stop when grease fitting (5) at base of each lift cylinder (1) is 1 in. (3 cm) above suspension link (6).
  - (2) Pull down on positioning cylinders lever (7) to extend positioning cylinders (3) approximately 2 ft (0.6 m).
  - (3) Repeat steps c(1) and c(2) as required to lift shelter (2) to a maximum of 60 in. (152 cm).

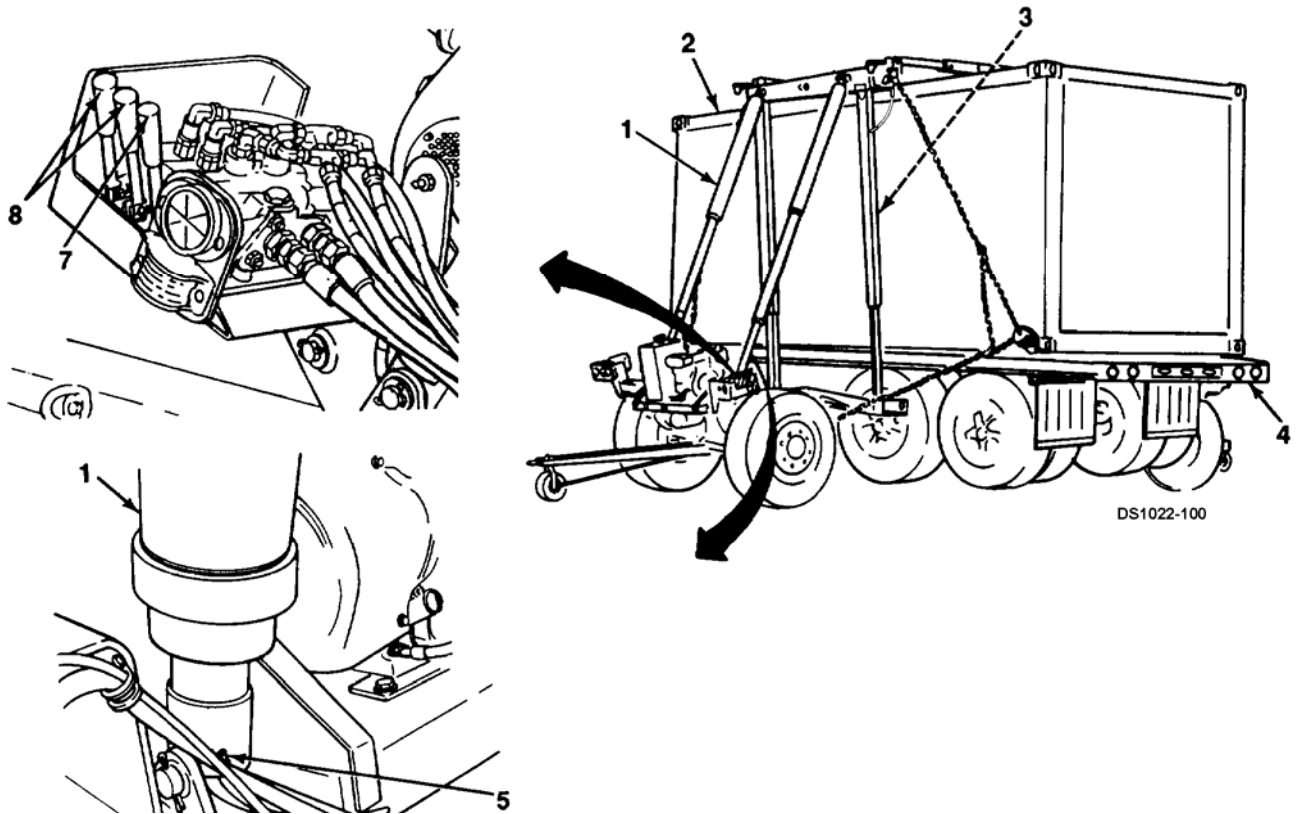
**CAUTION**

Use caution when backing trailer under shelter not to contact dolly halves.

- d. Back trailer (4) under shelter (2).



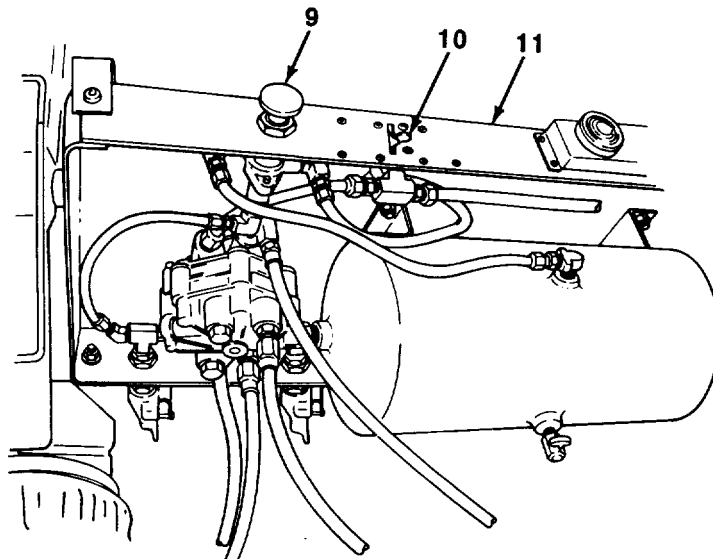
**2-14. RAISING DOLLY SET WITH SHELTER AND LOADING ONTO TRAILER (SIDE LIFT OPERATION) (Con't).**



**NOTE**

**Perform step e as required to aline shelter with bed of trailer.**

e. Release brakes on rear dolly by airbrake control knob (9). Parking brake lever (10) on pivoting tray (1) is in OFF position. Pull or tow front dolly forward in a straight line using the front drawbar to aid in alignment of shelter (2) to bed of trailer (4). Once alined, turn on brakes by pulling airbrake control knob.

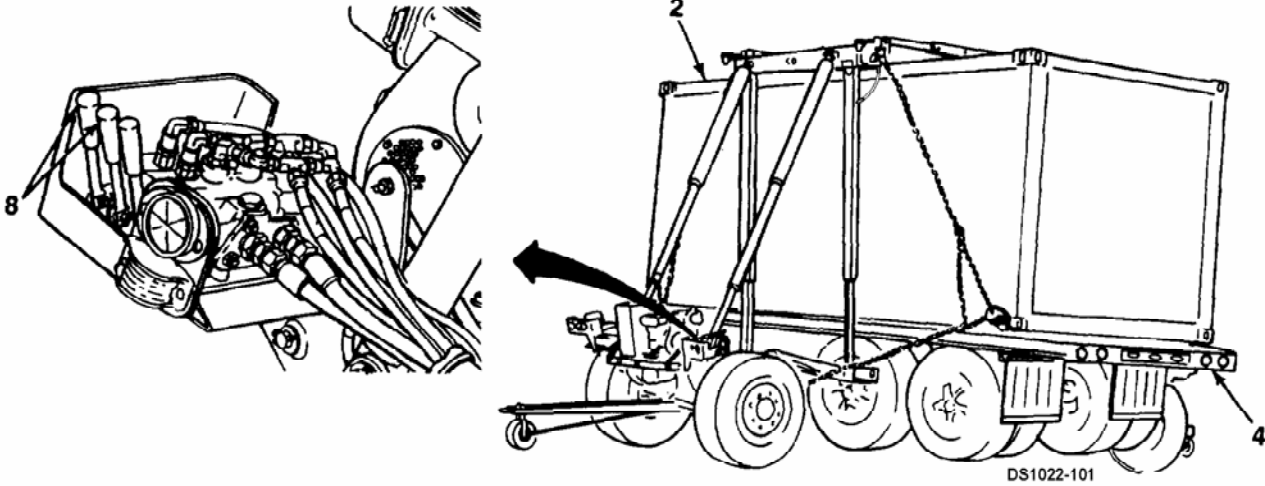


---

**2-14. RAISING DOLLY SET WITH SHELTER AND LOADING ONTO TRAILER (SIDE LIFT OPERATION) (Con't).**

---

- f. At front and rear, push up on two lift cylinder levers (8) to lower shelter (2) onto trailer (4).
- g. Secure shelter (2) to bed of trailer (4) with tie-downs.



---

## 2-15. DETACHING FRONT AND REAR DOLLIES FROM SHELTER (SHELTER ON TRAILER) (SIDE LIFT OPERATION).

---

### WARNING

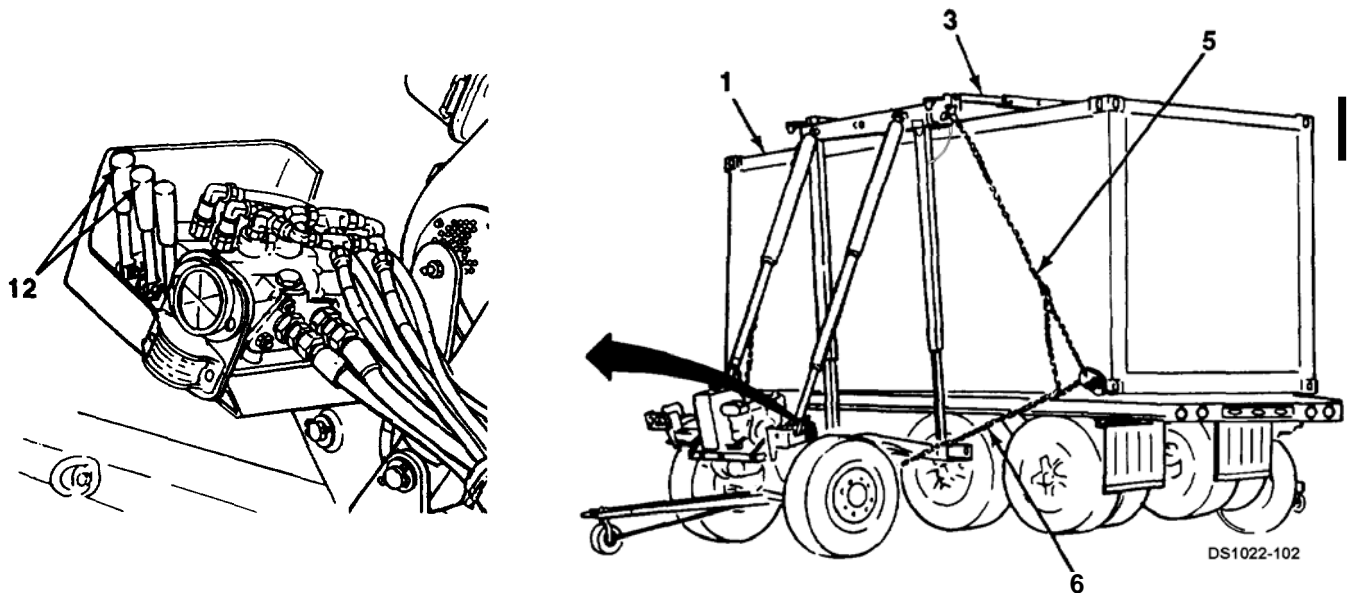
- All personnel must use caution when standing near dolly set, trailer, and shelter during detaching operations. Failure to follow this warning may cause serious injury or death to personnel.
- Front axle steering locking pin must ALWAYS be installed for side lift operation. Failure to follow this warning may cause front dolly to overturn, resulting in serious injury or death to personnel.
- Use extreme caution when using ladder. Have an assistant hold ladder to ensure that it is stable. Failure to follow this warning may cause serious injury to personnel.

### CAUTION

Use caution to ensure that lift cylinder grease fittings DO NOT contact suspension links and become damaged.

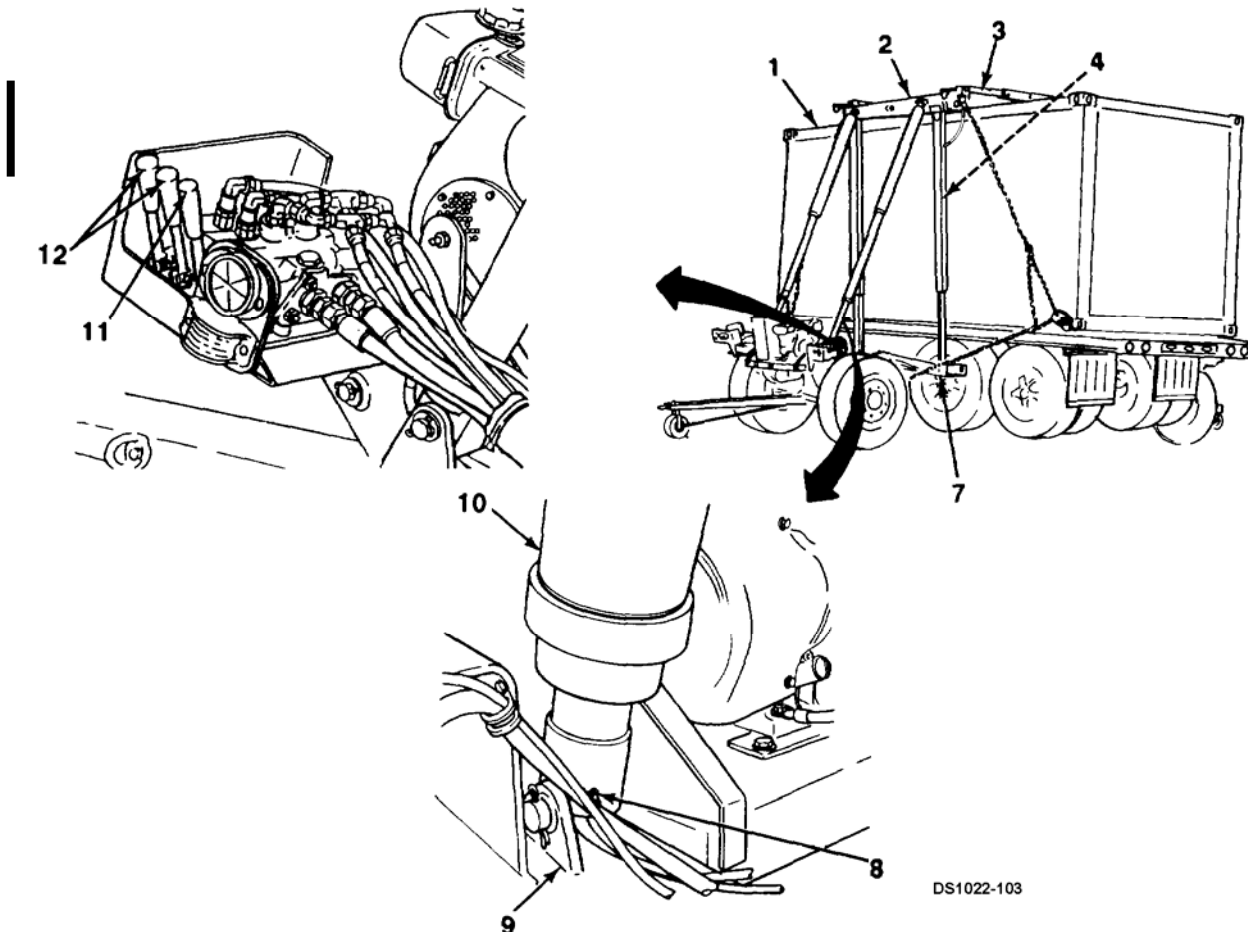
- a. At front and rear, perform the following steps:

(1) Push up on two lift cylinder levers (12) to lower crossbrace assemblies (3) onto top of shelter (1). Dolly set is now suspended by crossbrace assemblies. Lifting chains (5) and axle chains (6) should be slack.



**2-15. DETACHING FRONT AND REAR DOLLIES FROM SHELTER (SHELTER ON TRAILER)  
(SIDE LIFT OPERATION) (Cont).**

(2) Push up on positioning cylinders lever (11) to retract positioning cylinders (4). Stop when grease fitting (8) at base of each lift cylinder (10) is 1 in. (2.5 cm) from suspension link (9). This corresponds to an angle of approximately 30° between lift cylinder and suspension link.



b. At each bottom corner of shelter (1), remove hook (13) of take-up chain (14) from lifting chain (5).

**WARNING**

- Use extreme caution when removing twist locks. Keep hands and /or feet clear of bottom beams and from between beams. Failure to follow this warning may cause serious injury to personnel.
- Use extreme caution when loosening and removing twist locks. Loosened twist locks must be removed or they may fall, causing serious injury to personnel.

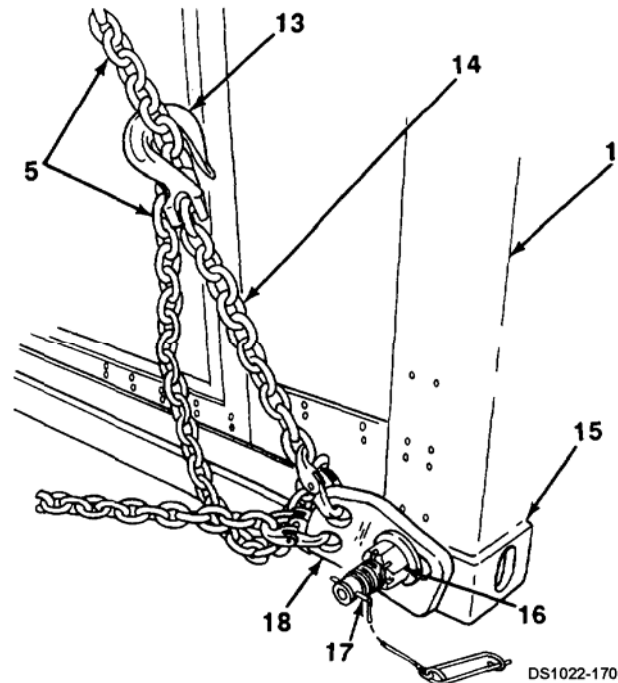
c. Use twist lock wrench (Item 3, Appendix D) to loosen nut (16). Rotate twist lock (17) 90° and remove twist lock and adapter (18) from each corner block (15).

---

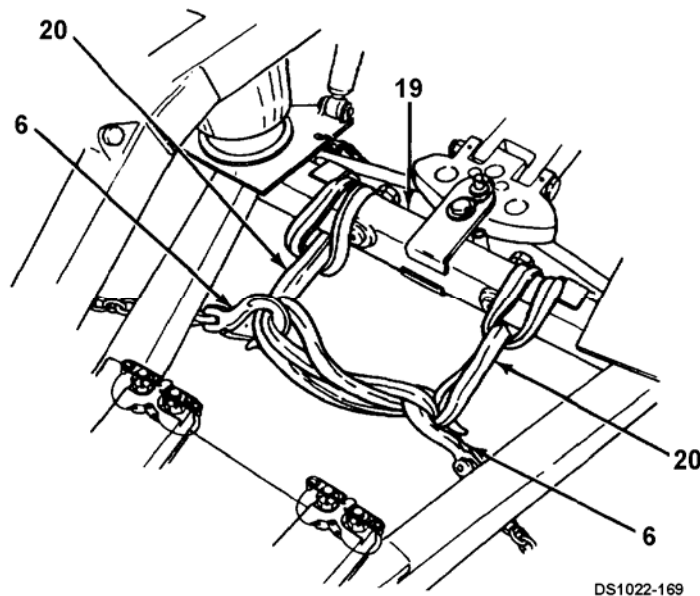
**2-15. DETACHING FRONT AND REAR DOLLIES FROM SHELTER (SHELTER ON TRAILER)  
(SIDE LIFT OPERATION) (Cont).**


---

d. At front and rear, pull down on positioning cylinders lever (11) to extend positioning cylinders (4) and lower bottom beam (7) to the ground.



e. At front and rear, remove two axle chains (6) from slings (20). Remove two slings from axle (19).



f. At front and rear, pull down on two lift cylinder levers (12) to raise top beam (2) until crossbrace assemblies (3) are slightly above shelter (1).

g. Deflate all air bags (see paragraph 2-8).

**2-15. DETACHING FRONT AND REAR DOLLIES FROM SHELTER (SHELTER ON TRAILER)  
(SIDE LIFT OPERATION) (Cont).**

**WARNING**

- Use extreme caution when climbing and working on top of shelter during side lift operations. Ensure that top of shelter is free of ice or debris which could cause slips and falls. When working with twist locks from on top of shelter, maintain a three-point contact with shelter as much as possible. When on top of shelter, always be aware of where other personnel and tools are located to prevent accidental bumps and trips. Failure to follow this warning may cause serious injury to personnel.
- Use extreme caution when removing twist locks. Keep hands and /or feet clear of top hooks, top beams, and from between beams. Failure to follow this warning may cause serious injury to personnel.
- Use extreme caution when loosening and removing twist locks. Loosened twist locks must be removed or they may fall, causing serious injury to personnel.

**NOTE**

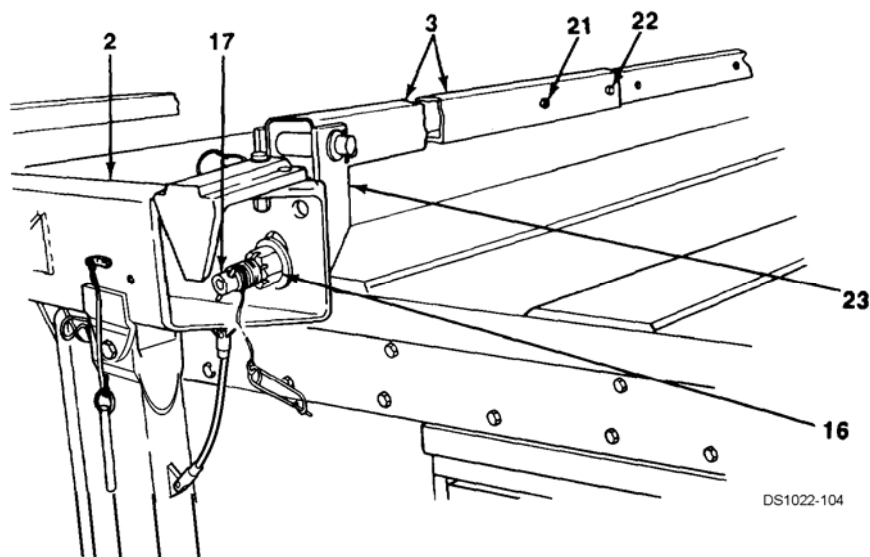
If there is difficulty loosening twist lock nut, or twist locks do not come out, it may be necessary to operate hydraulic control valve to slightly retract or extend each lift cylinder (see paragraph 2-21).

h. Use twist lock wrench (Item 3, Appendix D) to loosen nuts (16). Rotate two twist locks (17) 90° and remove from crossbrace assemblies (3). Rotate twist locks 90° again and remove from top beams (2). Remove crossbrace assemblies from between top beams.

**NOTE**

**Two extra detent pins are stowed in storage box.**

- i. Remove two detent pins (21 and 22) and collapse each crossbrace assembly (3). Install detent pin (21) to secure crossbrace assembly in collapsed position.
- j. Fold two crossbrace brackets (23) over each crossbrace assembly (3).



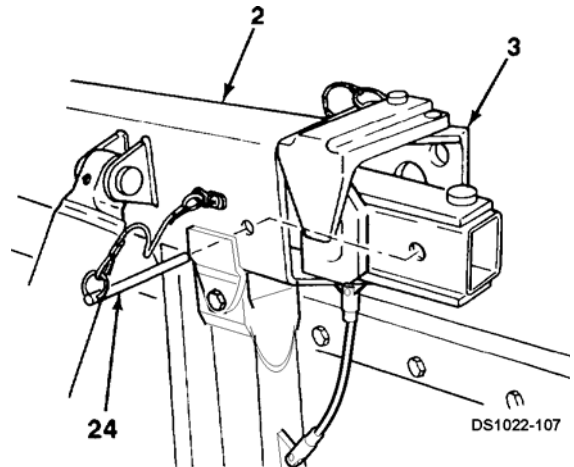
DS1022-104

**2-15. DETACHING FRONT AND REAR DOLLIES FROM SHELTER (SHELTER ON TRAILER) (SIDE LIFT OPERATION) (Cont).**

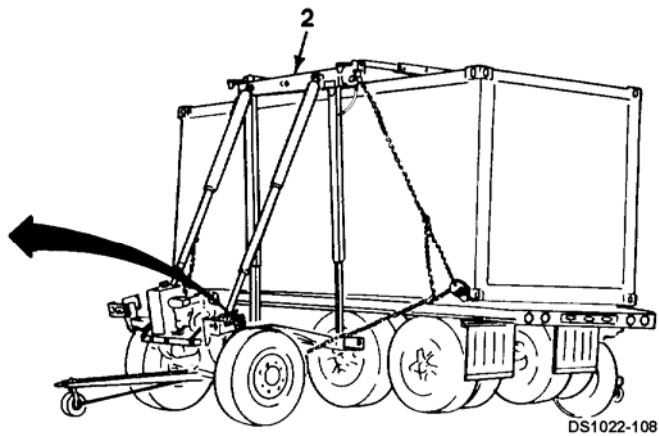
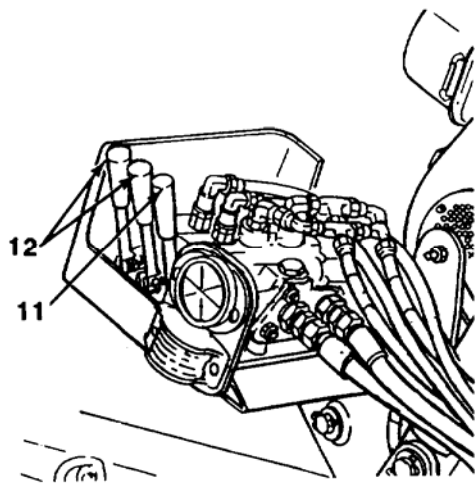
**WARNING**

All personnel standing on ground **MUST** stand clear when crossbrace assemblies are being stowed in top beams. If a crossbrace assembly is dropped, serious injury or death to personnel could result.

k. At front and rear, stow crossbrace assembly (3) in top beam (2) and retain with detent pin (24).



l. At front and rear, push up on two lift cylinder levers (12) and positioning cylinders lever (11) to fully lower top beam (2).

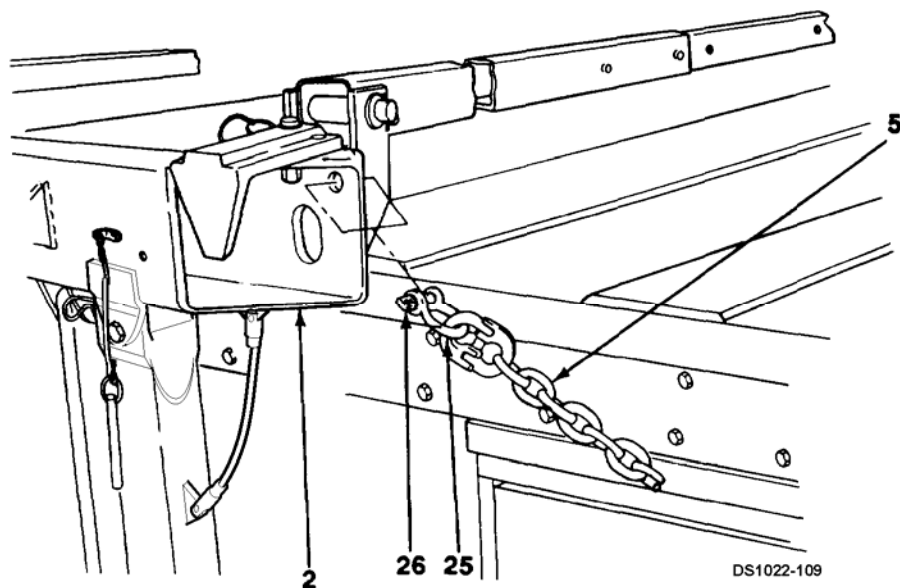


---

**2-15. DETACHING FRONT AND REAR DOLLIES FROM SHELTER (SHELTER ON TRAILER)  
(SIDE LIFT OPERATION) (Cont).**

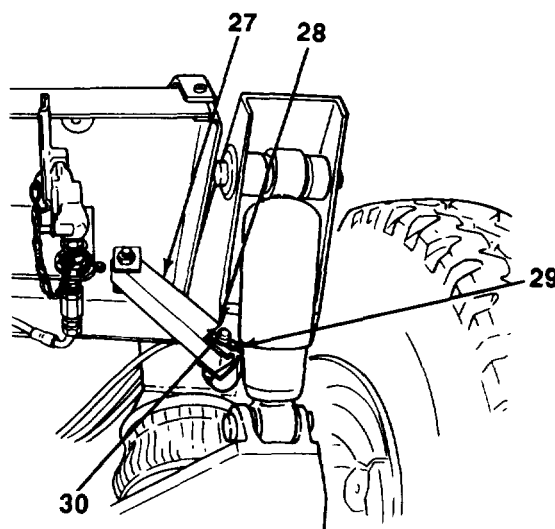
---

m. At front and rear, remove pin (26) from shackle (25) and remove lifting chain (5) from hole at each end of top beam (2).



n. At front and rear, secure pivoting tray lock-out brace (27) to lower bracket (28) with hitch pin (30) and safety pin (29).

o. Stow side lift kit components in storage box and basic issue items in toolbox on front dolly.



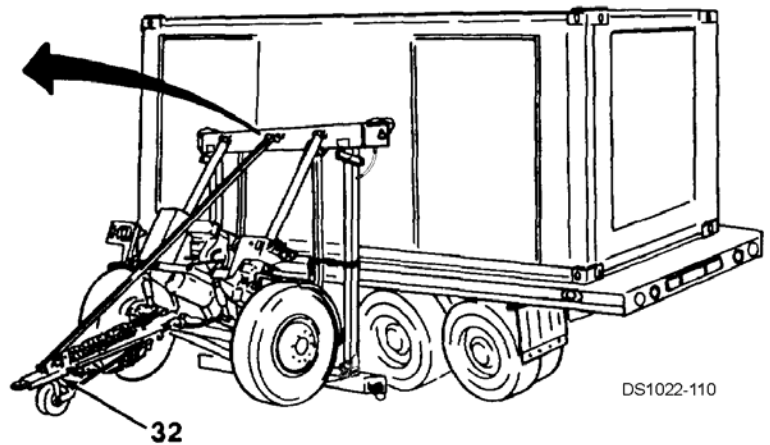
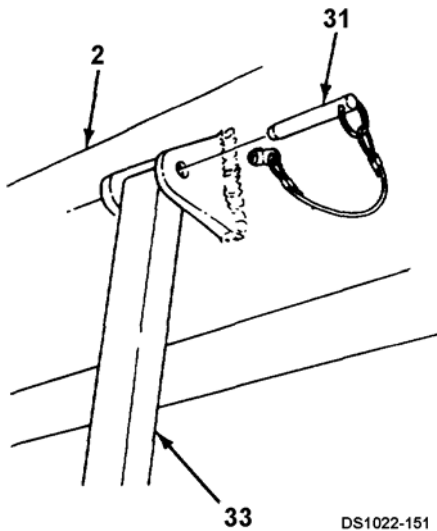


---

**2-15. DETACHING FRONT AND REAR DOLLIES FROM SHELTER (SHELTER ON TRAILER) (SIDE LIFT OPERATION) (Cont).**

---

p. At front and rear, install telescopic brace (33) to top beam (2) and drawbar (32) with two detent pins (31).



- q. Place each dolly half in maneuvering position (see paragraph 2-21 b).
- r. Pull trailer away.

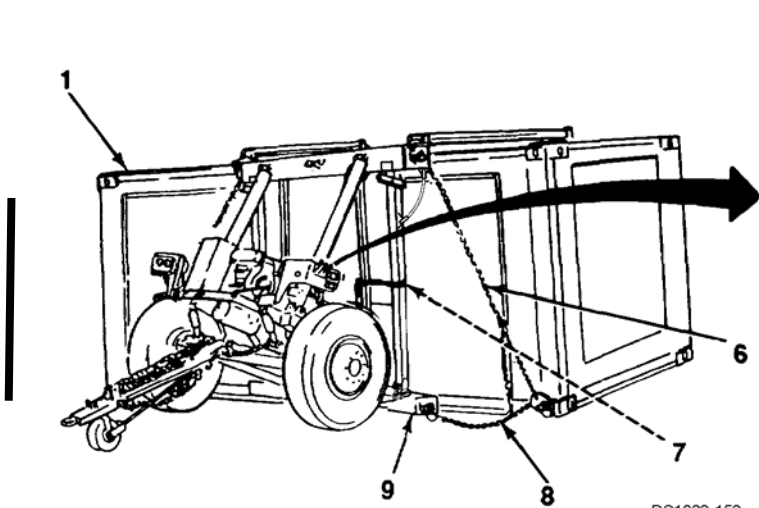
---

**2-16. DETACHING FRONT AND REAR DOLLIES FROM SHELTER (SHELTER ON GROUND)  
(SIDE LIFT OPERATION).**

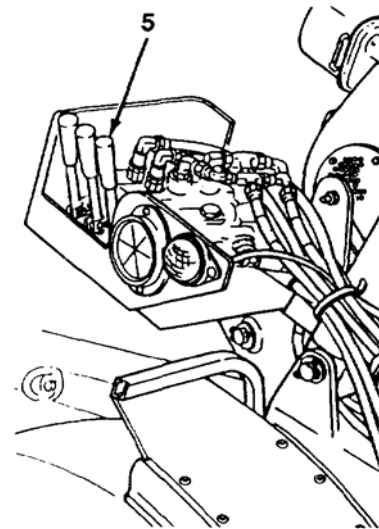
---

**WARNING**

- All personnel must use caution when standing near dolly set and shelter during detaching operations. Failure to follow this warning may cause serious injury or death to personnel.
  - Front axle steering locking pin must **ALWAYS** be installed for side lift operation. Failure to follow this warning may cause front dolly to overturn, resulting in serious injury or death to personnel.
  - Use extreme caution when using ladder. Have an assistant hold ladder to ensure that it is stable. Failure to follow this warning may cause serious injury to personnel.
- a. At front and rear, pull down on positioning cylinders lever (5) to extend positioning cylinders (7) and lower bottom beam (9) to the ground. Ensure that there is slack in lifting chains (6) and axle chains (8).



DS1022-152



DS1022-153

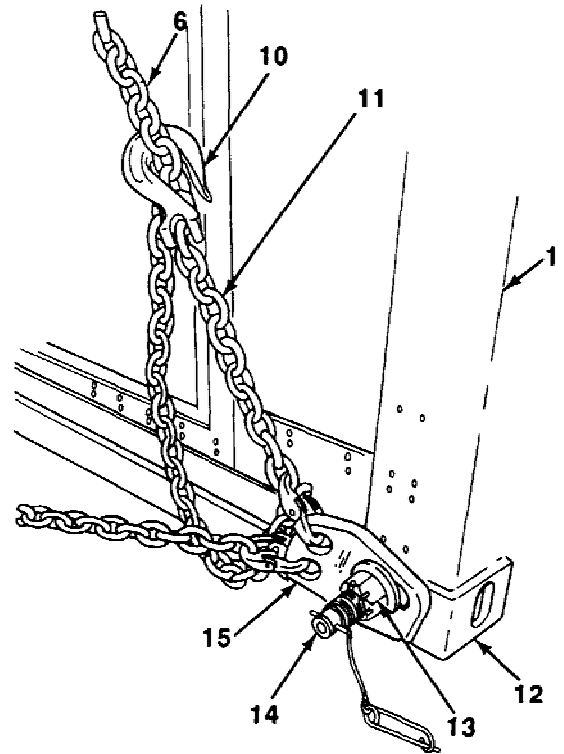
## 2-16. DETACHING FRONT AND REAR DOLLIES FROM SHELTER (SHELTER ON GROUND) (SIDE LIFT OPERATION) (Cont).

b. At each bottom corner of shelter (1), remove hook (10) of take-up chain (11) from lifting chain (6).

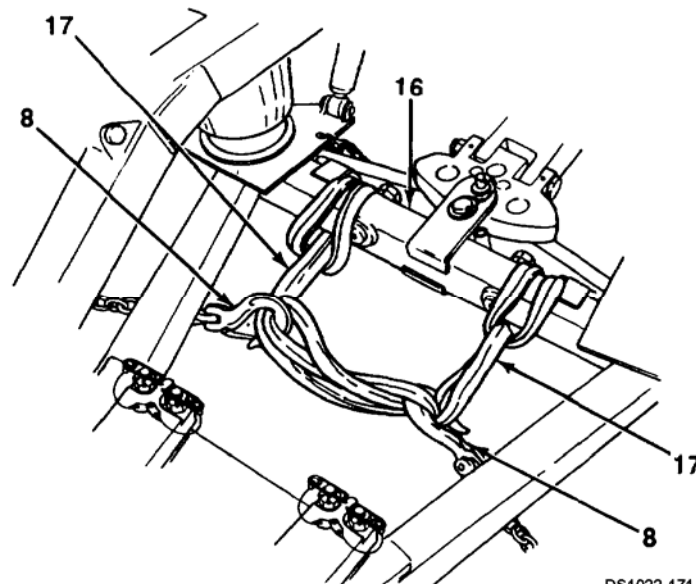
**WARNING**

Use extreme caution when removing twist locks. Keep hands and /or feet clear of bottom beams and from between beams. Failure to follow this warning may cause serious injury to personnel.

c. Use twist lock wrench (Item 3, Appendix D) to loosen nut (13). Rotate twist lock (14) 90° and remove twist lock and adapter (15) from each corner block (12).



d. At front and rear, remove two axle chains (8) from slings (17). Remove two slings from axle (16).



DS1022-171

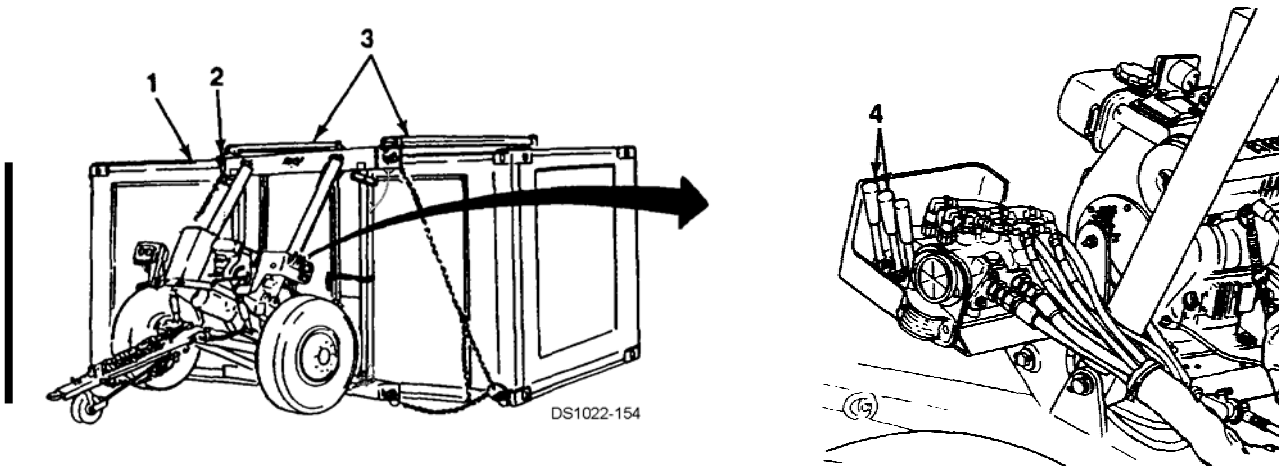
---

**2-16. DETACHING FRONT AND REAR DOLLIES FROM SHELTER (SHELTER ON GROUND) (SIDE LIFT OPERATION) (Cont).**

---

e. At front and rear, pull down on two lift cylinder levers (4) to raise top beam (2) until crossbrace assemblies (3) are slightly above shelter (1).

f. Deflate all air bags (see paragraph 2-8).



**WARNING**

- Use extreme caution when climbing and working on top of shelter during side lift operations. Ensure that top of shelter is free of ice or debris which could cause slips and falls. When working with twist locks from on top of shelter, maintain a three-point contact with shelter as much as possible. When on top of shelter, always be aware of where other personnel and tools are located to prevent accidental bumps and trips. Failure to follow this warning may cause serious injury to personnel.
- Use extreme caution when removing twist locks. Keep hands and/or feet clear of top hooks, top beams, and from between beams. Failure to follow this warning may cause serious injury to personnel.
- Use extreme caution when loosening and removing twist locks. Loosened twist locks must be removed or they may fall, causing serious injury to personnel.

**NOTE**

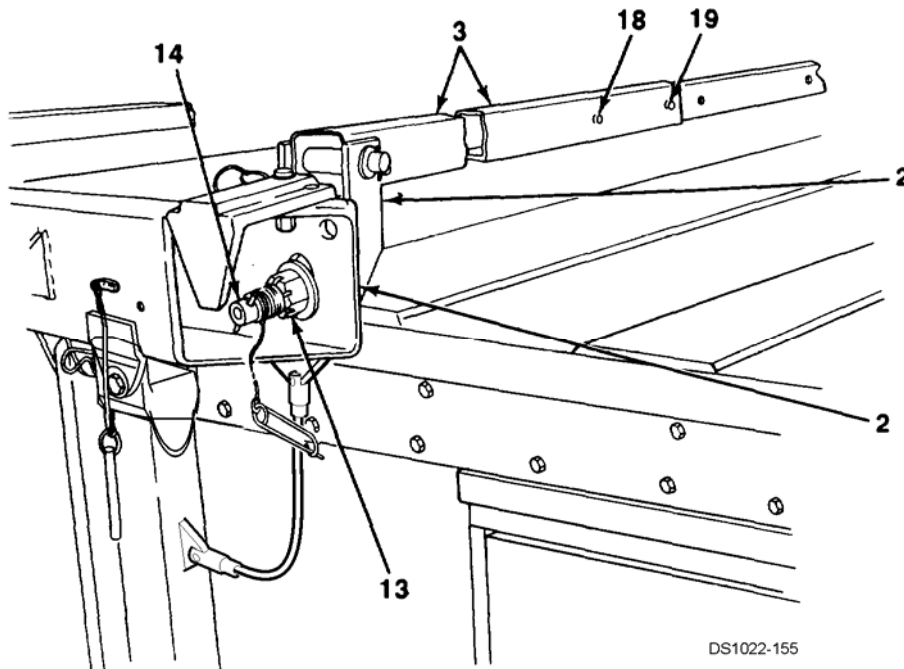
If there is difficulty loosening twist lock nut, or twist locks do not come out, it may be necessary to operate hydraulic control valve to slightly retract or extend each lift cylinder (see paragraph 2-21).

---

**2-16. DETACHING FRONT AND REAR DOLLIES FROM SHELTER (SHELTER ON GROUND)  
(SIDE LIFT OPERATION) (Cont).**


---

g. At front and rear, use twist lock wrench (Item 3, Appendix D) to loosen nuts (13). Rotate two twist locks (14) 90° and remove from crossbrace assemblies (3). Rotate twist locks 90° again and remove from top beams (2). Remove crossbrace assemblies from between top beams.

**NOTE**

**Two extra detent pins are stowed in storage box.**

h. Remove two detent pins (18 and 19) and collapse each crossbrace assembly (3). Install detent pin (18) to secure crossbrace assembly in collapsed position.

i. Fold two crossbrace brackets (20) over each crossbrace assembly (3).

---

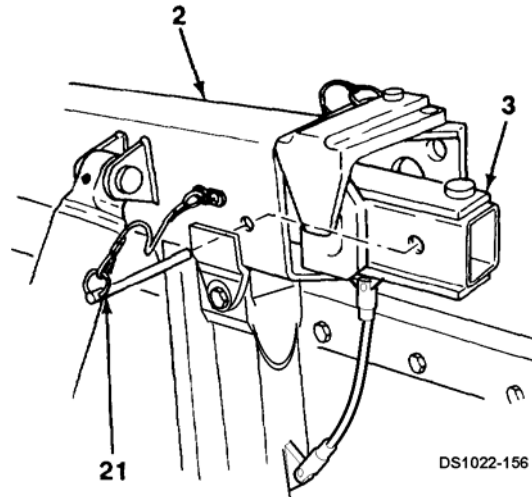
**2-16. DETACHING FRONT AND REAR DOLLIES FROM SHELTER (SHELTER ON GROUND)  
(SIDE LIFT OPERATION) (Cont).**

---

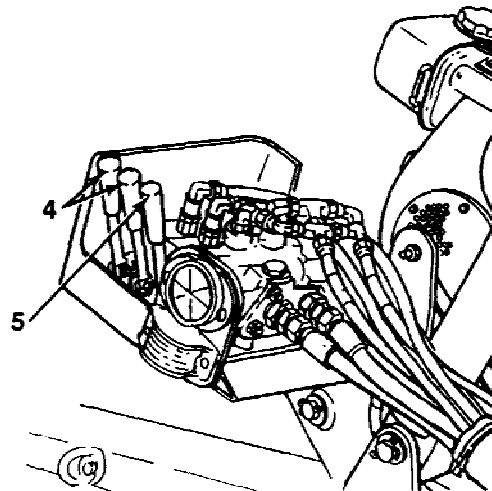
**WARNING**

All personnel standing on ground **MUST** stand clear when crossbrace assemblies are being stowed in top beams. If a crossbrace assembly is dropped, serious injury or death to personnel could result.

- j. At front and rear, stow crossbrace assembly (3) in top beam (2) and retain with detent pin (21).

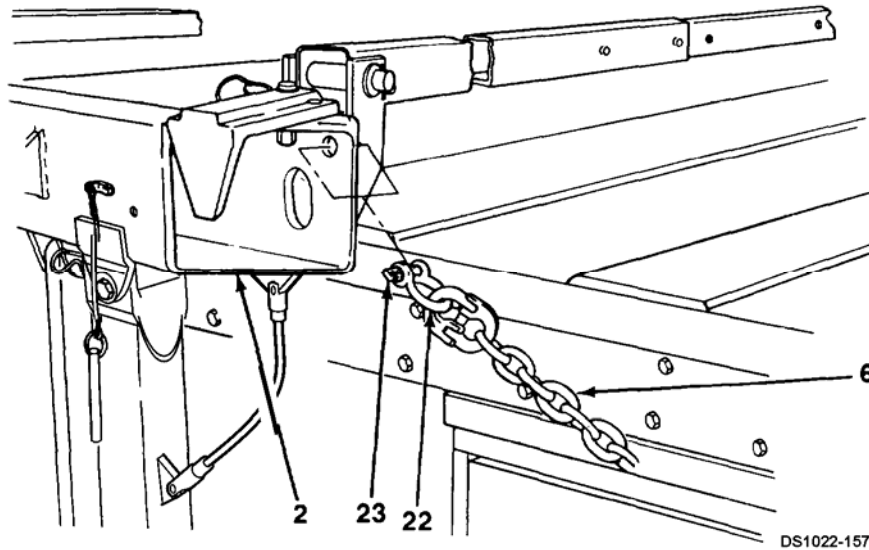


- k. At front and rear, push up on two lift cylinder levers (4) and positioning cylinders lever (5) to fully lower top beam (2).



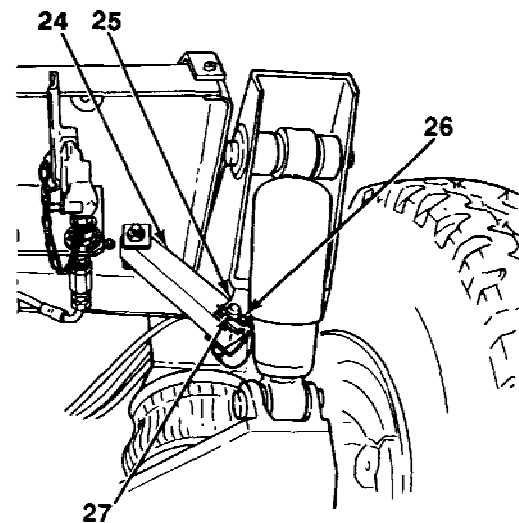
**2-16. DETACHING FRONT AND REAR DOLLIES FROM SHELTER (SHELTER ON GROUND) (SIDE LIFT OPERATION) (Cont).**

l. At front and rear, remove pin (23) from shackle (22) and remove lifting chain (6) from hole at each end of top beam (2).



m. At front and rear, secure pivoting tray lock-out brace (24) to lower bracket (25) with hitch pin (27) and safety pin (26).

n. Stow side lift kit components in storage box and basic issue items in toolbox on front dolly.

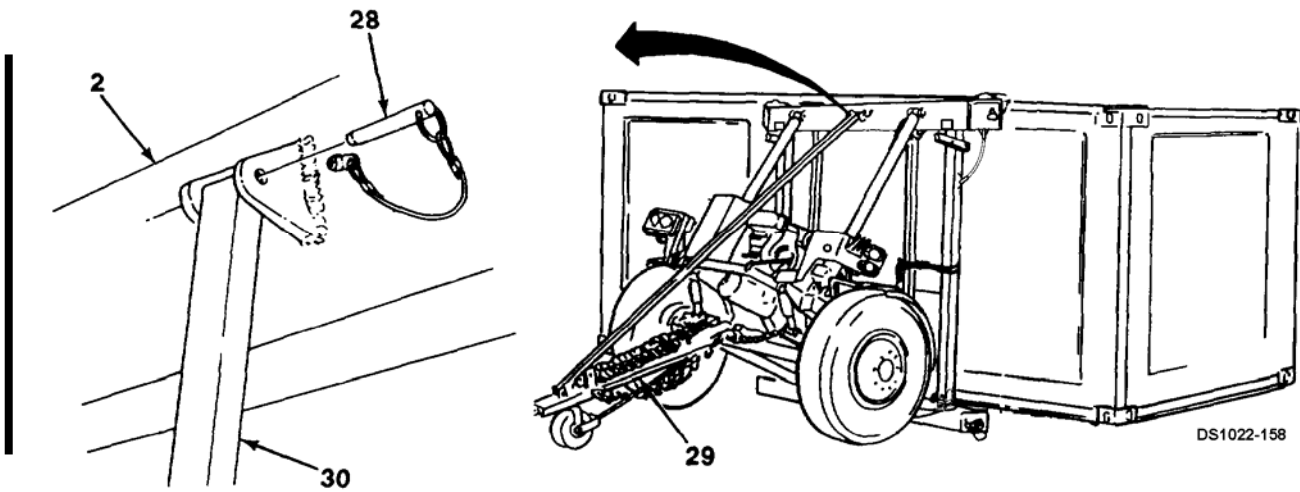


---

**2-16. DETACHING FRONT AND REAR DOLLIES FROM SHELTER (SHELTER ON GROUND)  
(SIDE LIFT OPERATION) (Cont).**

---

- o. At front and rear, install telescopic brace (30) to top beam (2) and drawbar (29) with two detent pins (28).



- p. Place each dolly half in maneuvering position (see paragraph 2-21b).



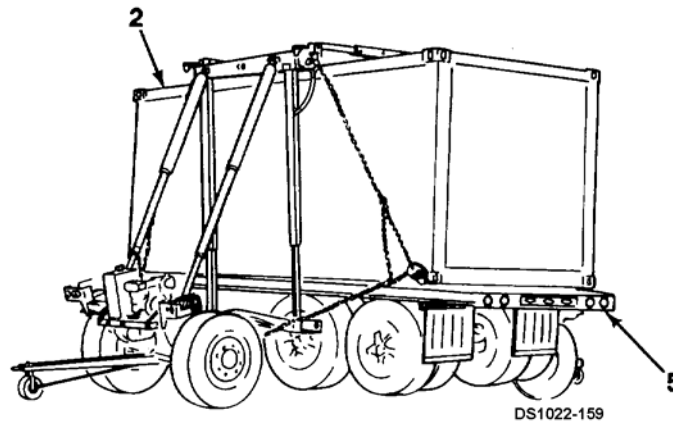
---

**2-17. LOWERING DOLLY SET WITH SHELTER FROM TRAILER (SIDE LIFT OPERATION).**


---

**WARNING**

- All personnel must use caution when standing near dolly set, shelter, and trailer during lowering operations. Failure to follow this warning may cause serious injury or death to personnel.
  - Front axle steering locking pin must ALWAYS be installed for ride lift operation. Failure to follow this warning may cause front dolly to overturn, resulting in serious injury or death to personnel.
- a. Attach front and rear dollies to shelter loaded on trailer (see paragraph 2-13).
  - b. Remove all tie-downs securing shelter (2) to bed of trailer (5).



- c. Locate a third person within view of each control valve operator. To ensure that shelter is lowered evenly, third person should use the following hand signals using the index finger of each hand:
  - (1) Pointing UP - Extend lift cylinders.
  - (2) Pointing DOWN - Retract lift cylinders.
  - (3) Pointing horizontally OUTWARD - Extend positioning cylinders.
  - (4) Pointing horizontally INWARD - Retract positioning cylinders.
  - (5) Showing a FIST - Stop or hold.

---

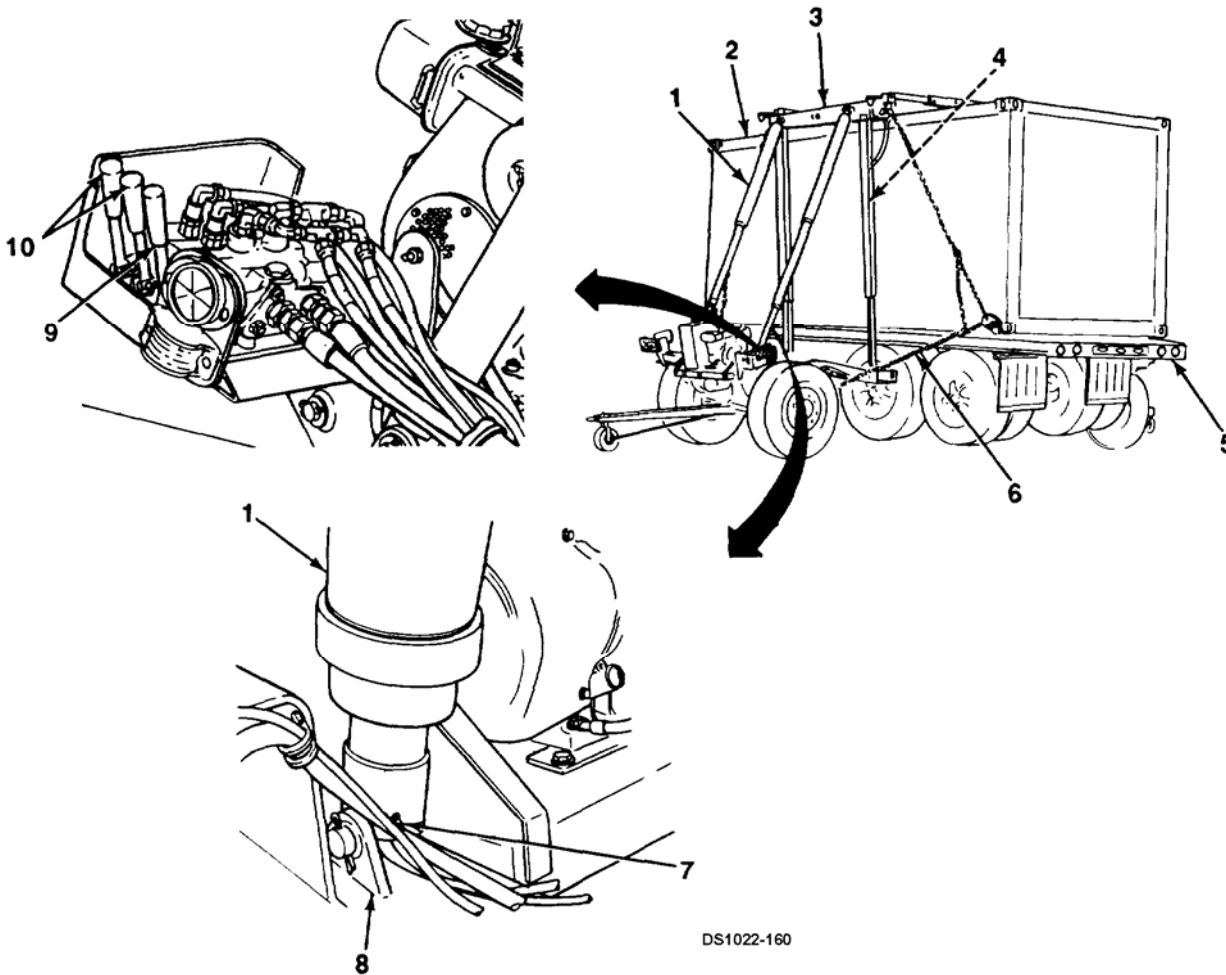
**2-17. LOWERING DOLLY SET WITH SHELTER FROM TRAILER (SIDE LIFT OPERATION) (Cont).**

---

**NOTE**

**As top beams are raised, dolly halves will move away from shelter and axle chains will come under full tension; this is normal.**

d. At front and rear, pull down on two lift cylinder levers (10) to raise top beam (3) until axle chains (6) are under full tension. **DO NOT** lift shelter (2) off bed of trailer (5).

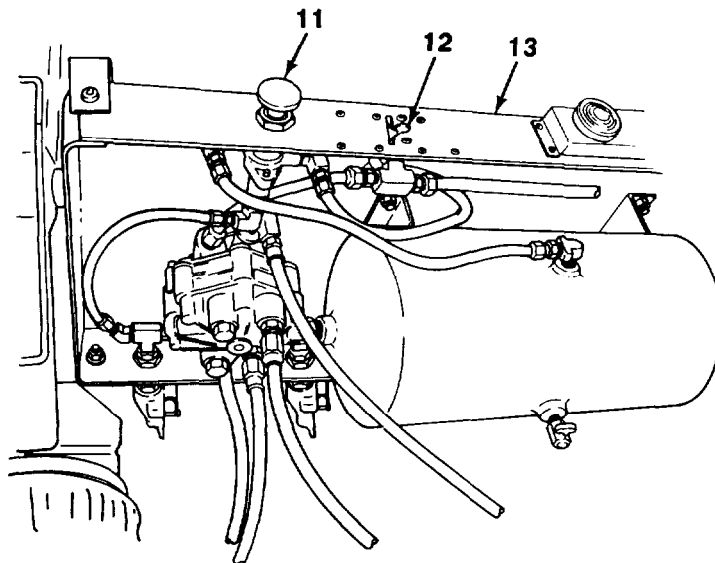


---

## 2-17. LOWERING DOLLY SET WITH SHELTER FROM TRAILER (SIDE LIFT OPERATION) (Con't).

---

e. Apply brakes on rear dolly by pulling airbrake control knob (11). Parking brake lever (12) on pivoting tray (13) is in OFF position.



f. At front and rear, pull down on two lift cylinder levers (10) to raise shelter (2) approximately 2 in. (5 cm) above bed of trailer (5).

**CAUTION**

Use caution when removing trailer from under shelter not to contact dolly halves.

g. Pull trailer (5) away.

**CAUTION**

- During lowering operations, use caution to ensure that shelter is kept level. Failure to follow this caution may cause damage to shelter or dolly set.
- During lowering operations, use caution to ensure that lift cylinder grease fittings **DO NOT** contact suspension links and become damaged.

h. At front and rear, perform the following steps to lower shelter (2) to the ground.

(1) Push up on two lift cylinder levers (10) to retract lift cylinders (1). Stop when grease fitting (7) at base of each lift cylinder is 1 in. (2.5 cm) above suspension link (8). This corresponds to an angle of approximately 30° between lift cylinder and suspension link.

(2) Push up on positioning cylinders lever (9) to retract positioning cylinders (4) approximately 2 ft (0.6 m).

(3) Repeat steps h(1) and h(2) as required until shelter (2) is on the ground.

i. Detach front and rear dollies from shelter (see paragraph 2-16).

---

## 2-18. GENERAL TOWING INSTRUCTIONS.

---

### NOTE

- The dolly set may be towed in a four-wheel configuration, with or without shelter. Two dolly sets without shelters may be towed in tandem for off public road use ONLY (see paragraph 2-19). Although towing arrangements and length of the overall unit may differ, the same general principles of safe towing apply.
- M939 Series Cargo Trucks must be loaded with at least 3 tons of payload when towing a fully loaded dolly set.
- There is no spare tire mounted on the dolly set. A spare must be obtained from the towing vehicle or the motor pool.
- Refer to FM 21-305 for further information on safe towing practices.

#### a. Driving.

**WARNING**

Steering locking pin **MUST** be removed from front axle and steering link before dolly set is towed in a four-wheel configuration. Failure to unlock steering will damage steering linkage and may result in an accident.

(1) Check to ensure steering locking pin has been placed in stowed position in front axle stowage tube (see paragraph 2-11).

(2) Keep in mind the overall length of towing vehicle and dolly set (with or without shelter) when passing other vehicles, turning, stopping, and backing.

(3) Do not exceed maximum towing speed for towing configuration and road surface (see paragraph 1-15).

**CAUTION**

A ground guide should be used when towing vehicle driver is maneuvering in tight turns over 180°. In turns over 180°, towing vehicle may contact dolly set tires. Failure to follow this caution may cause damage to dolly set.

b. Turning. When turning comes, remember that dolly set wheels turn inside the turning radius of towing vehicle. Make a right turn by driving towing vehicle approximately halfway into intersection, then cutting sharply to the right. This will keep dolly set wheels off curb.

c. Stopping. During normal operation, brakes of towing vehicle and dolly set are applied at the sametime. Apply brakes gradually and smoothly.

d. Parking. When leaving towing vehicle and dolly set unattended, set parking brakes on towing vehicle and rear dolly, or rear dollies if tandem towing.

#### e. Backing.

(1) When dolly set must be backed up in a straight line without turning, steering locking pin should be installed in front axle and steering link to lock steering. When dolly set must be turned while backing up, steering locking pin must be removed and stowed, to unlock steering.

---

**2-18. GENERAL TOWING INSTRUCTIONS (Con't).**

---

(2) Adjust rearview mirrors before backing. Have an assistant guide you while backing.

(3) When towing vehicle and dolly set are in a straight line, rear of dolly set will move in opposite direction of which front towing vehicle wheels are turned (e.g., when towing vehicle wheels are turned to right, rear of dolly set will move to left; when towing vehicle wheels are turned to left, rear of dolly set will move to right).

(4) To decrease angle of turn, gradually turn towing vehicle wheels in direction dolly set is moving. This will gradually decrease angle until towing vehicle and dolly set are in a straight line.

f. **Shelter Access.** To ensure access into shelter through its door, rear dolly must be attached to door end of shelter. Door to shelter may be opened by raising shelter 1-2 in. (3-5 cm) using lift cylinders.

---

## 2-19. TANDEM TOWING.

---

**WARNING**

DO NOT tandem tow dolly sets with shelters. To safely tow two dolly sets, they must be empty. Tandem tow on off public roads ONLY. Observe a maximum towing speed of 25 mi/h (40 km/h). Failure to follow this warning may result in serious injury or death to personnel and damage to equipment.

a. Raising and Coupling Dolly Sets.

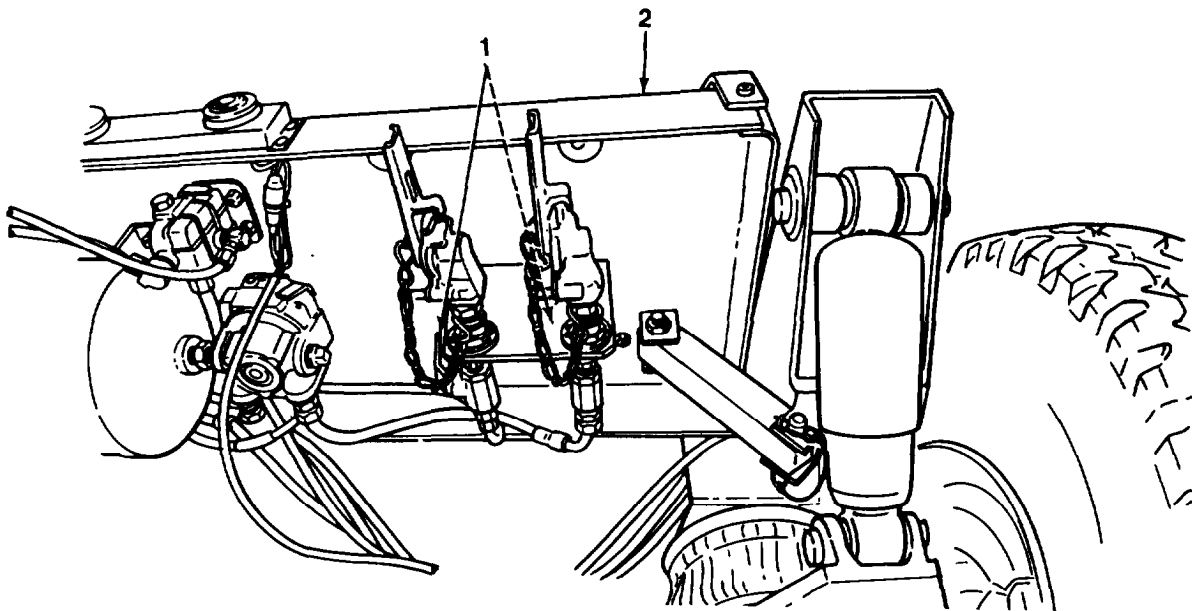
**WARNING**

All personnel must use caution when standing near dolly sets during raising and coupling operations. Failure to follow this warning may cause serious injury or death to personnel.

NOTE

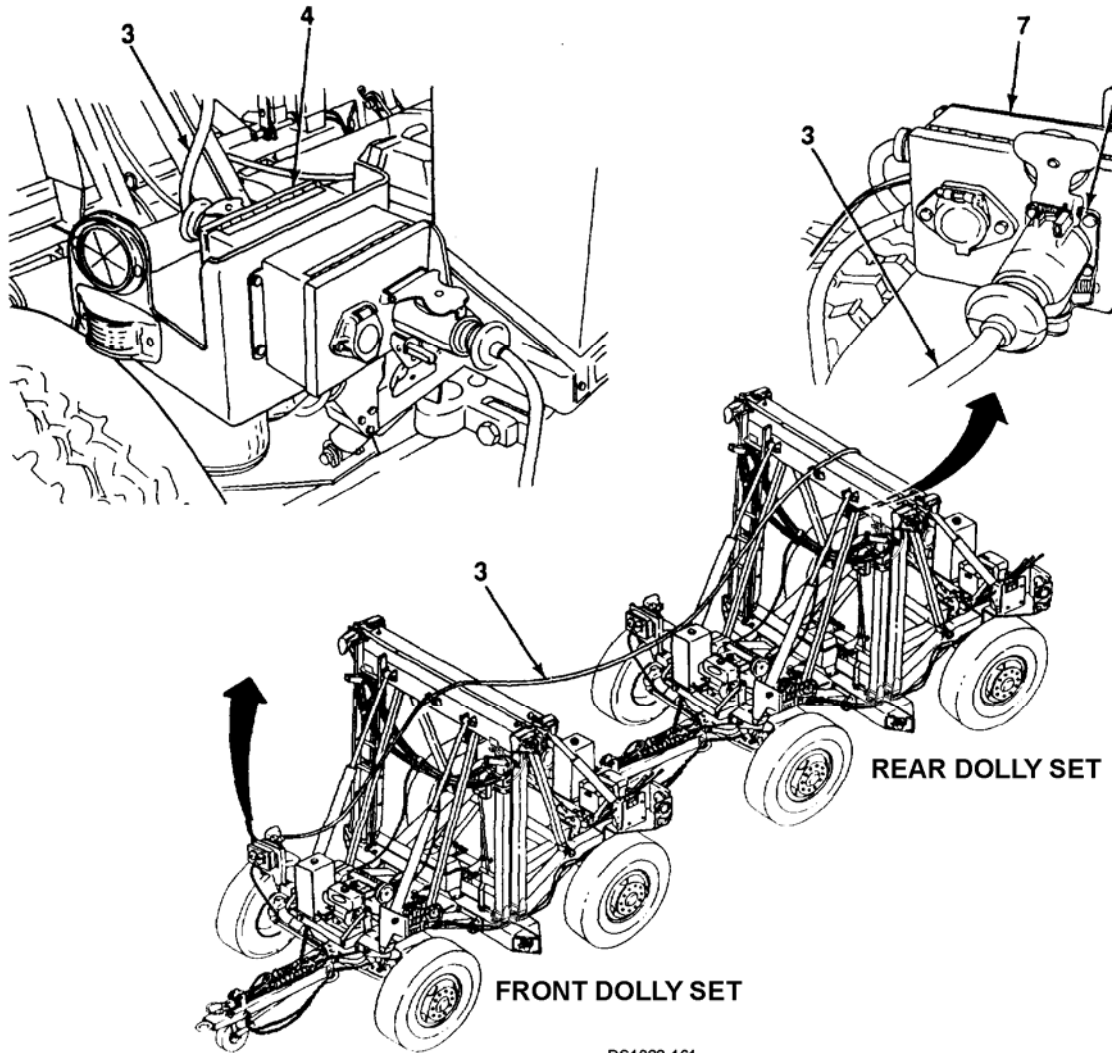
When fully coupled, lights on rear dolly of front dolly set will NOT be functioning.

- (1) Raise front dolly set and couple to towing vehicle (see paragraph 2-11).
- (2) Raise rear dolly set and couple to pintle assembly of front dolly set (see paragraph 2-11).
- (3) Open two shutoff valves (1) under pivoting tray (2) at rear of front dolly set.



**2-19. TANDEM TOWING (Con't).**

(4) Route and connect intradolly cable (3) between forward junction box (4) of front dolly set and 24-volt receptacle connector (8) at rear junction box (7) of rear dolly set.

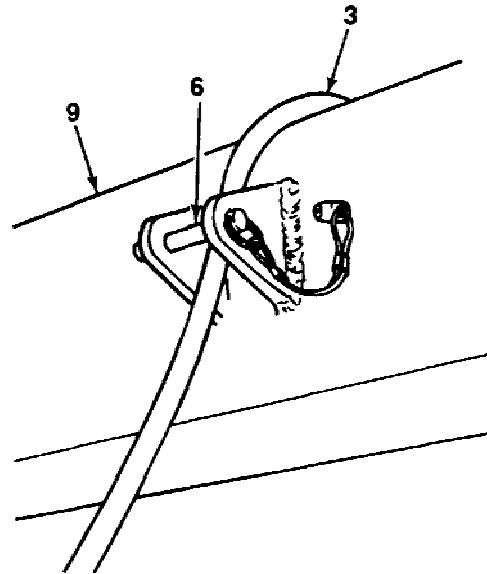


---

**2-19. TANDEM TOWING (Con't).**

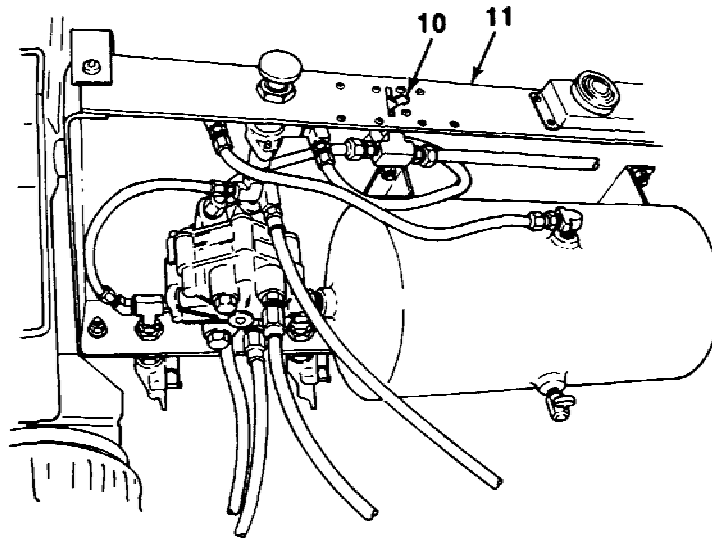
---

(5) Secure intradolly cable (3) under four telescopic brace detent pins (6) at midpoint of top beams (9).



(6) Release parking brakes on rear dolly of rear dolly set by turning parking brake lever (10) on pivoting tray (11) to OFF position.

(7) Using towing vehicle, pull dolly sets slightly forward and check operation of service brakes (see towing vehicle Operator's Manual).





---

**2-19. TANDEM TOWING (Con't).**


---

**NOTE**

**If towing vehicle has a 12-volt system, blackout stoplight-taillights will NOT be functioning.**

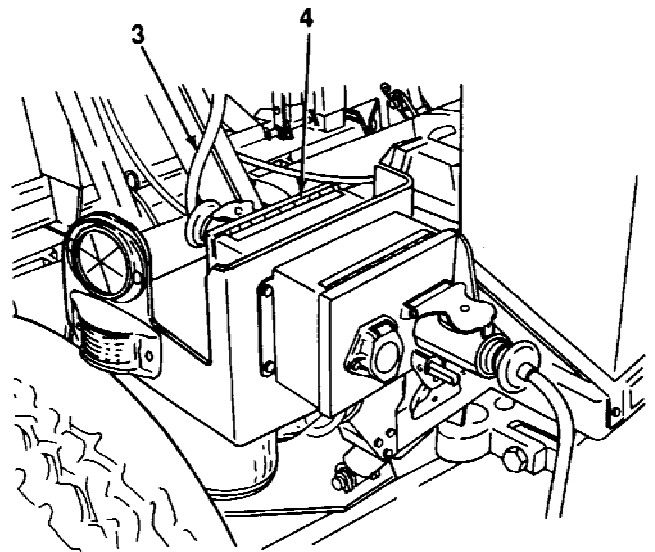
(8) Check operation of lights (see towing vehicle Operator's Manual). The only lights functioning will be marker clearance lights at front of front dolly set and rearmost lights of rear dolly set.

**b. Uncoupling Dolly Sets**

**WARNING**

**All personnel must use caution when standing near dolly sets during uncoupling operations. Failure to follow this warning may cause serious injury or death to personnel.**

- (1) Uncouple front dolly set from towing vehicle (see paragraph 2-7).
- (2) Disconnect intradolly cable (3) from forward junction box (4) of front dolly set.



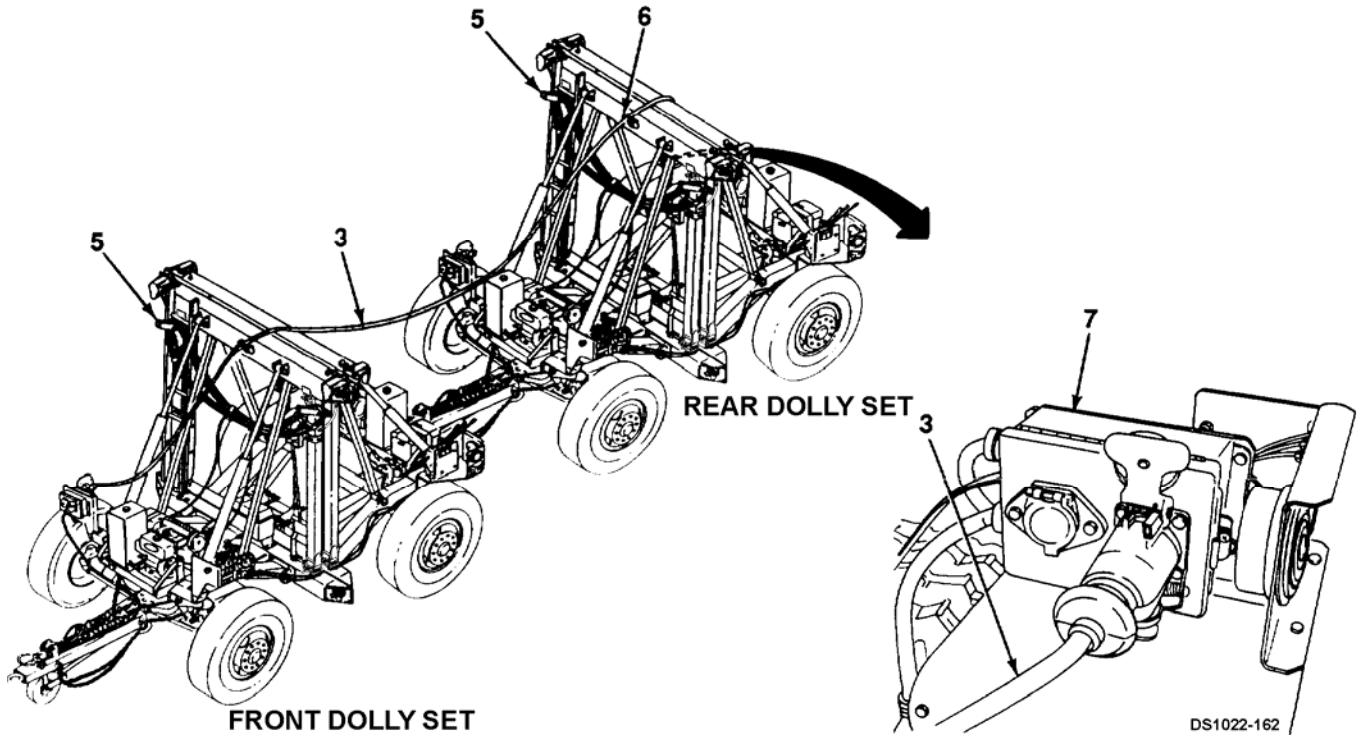
- (3) Apply parking brakes on rear dolly of rear dolly set. Set parking brake lever (10) on pivoting tray (11) to ON position.

---

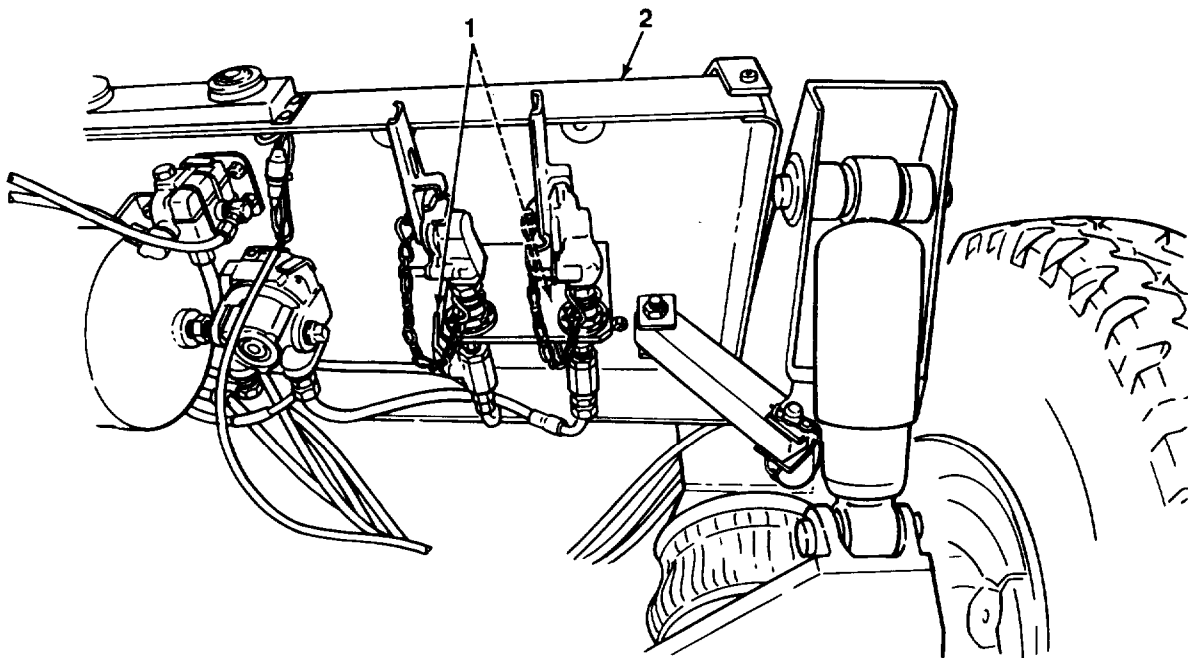
## 2-19. TANDEM TOWING (Con't).

---

(4) Disconnect intradolly cable (3) from rear junction box (7) of rear dolly set. Release intradolly cable from under four telescopic brace detent pins (6). Stow intradolly cable on hanger brackets (5).

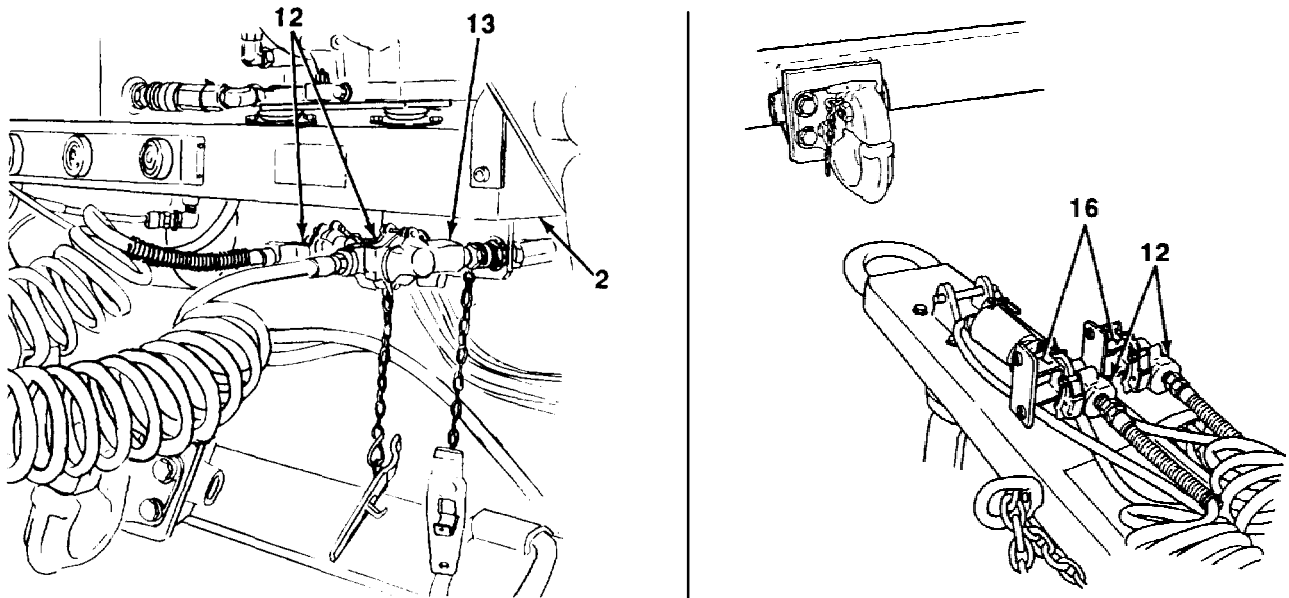


(5) Close two shutoff valves (1) under pivoting tray (2) at rear of front dolly set.

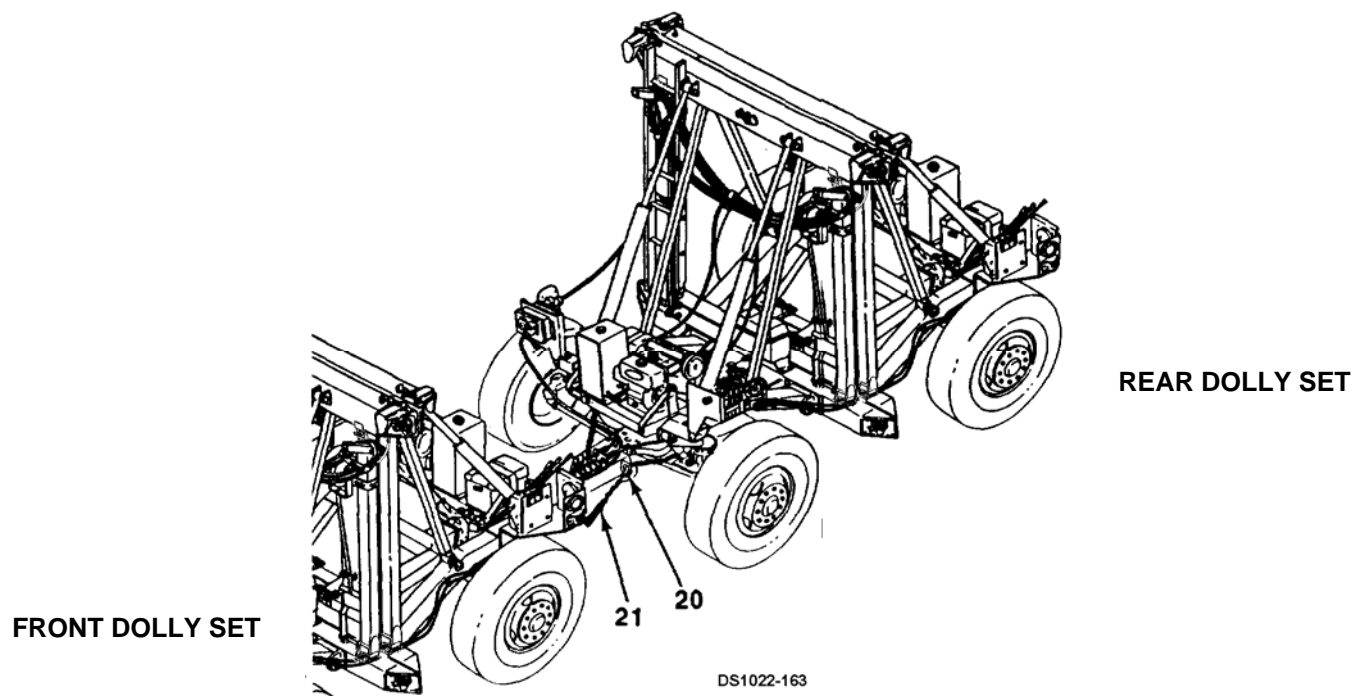


**2-19. TANDEM TOWING (Con't).**

(6) Disconnect intervehicular gladhands (12) of rear dolly set from gladhands (13) under pivoting tray (2) at rear of front dolly set. Stow intervehicular gladhands in dummy couplings (16).

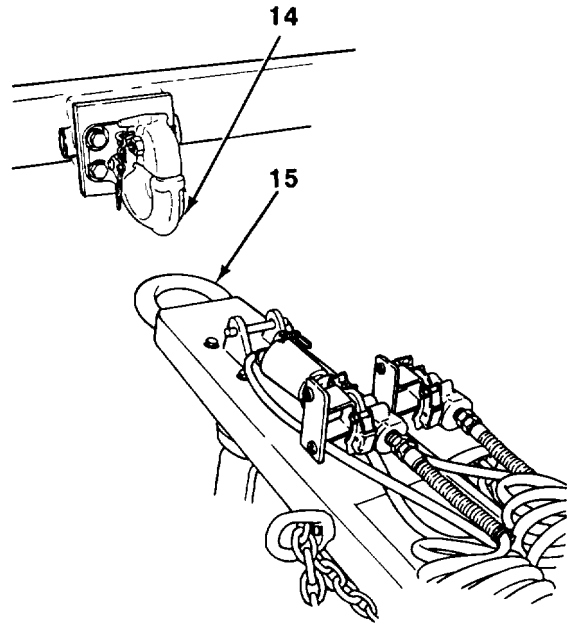


(7) Remove safety chains (21) from rear of front dolly set. Stow safety chains on rearmost eyebolts (20) of rear dolly set.

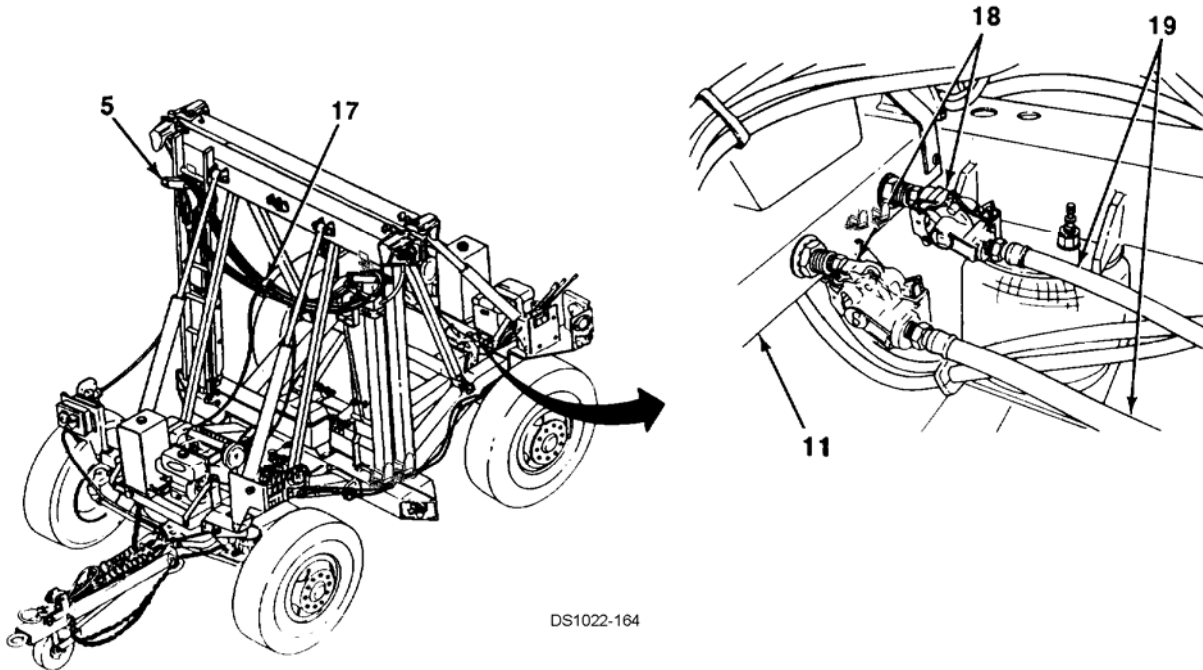


**2-19. TANDEM TOWING (Con't).**

(8) Remove safety pin and open pintle assembly (14) at rear of front dolly set. Lift off lunette (15) of rear dolly set. Close pintle assembly and install safety pin.



(9) Disconnect intradolly air hoses (19) from gladhands (18) at pivoting trays (11) of rear dolly set. Stow intradolly air hoses on hanger brackets (5). Secure intradolly air hoses and intradolly cable (3) with two stowage straps (17).



DS1022-164

**REAR DOLLY SET**

---

**2-20. OPERATING ENGINE.**


---



**WARNING**



- Carbon monoxide can be deadly. **DO NOT** operate engine in enclosed areas. Good ventilation is essential. Failure to follow this warning may result in serious injury or death to personnel.
- Always wear ear plugs or other type of hearing protection while engine is running. Damage to hearing will occur without protection.

**NOTE**

For instructions on operating engine in extreme cold [below 0°F (-18°C)], refer to paragraph 2-25.

a. Starting Engine.

**CAUTION**

**DO NOT** crank engine longer than ten seconds without its starting. If engine does not start within ten seconds, wait 30 seconds and try again. Failure to follow this caution may damage starter.

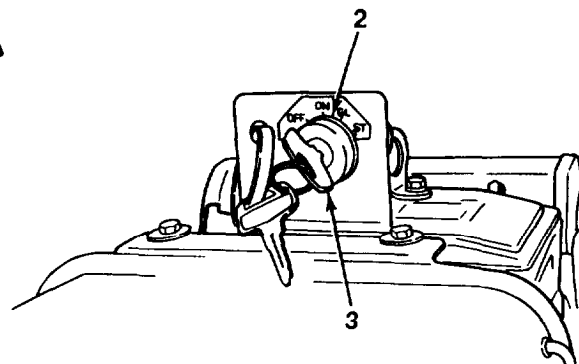
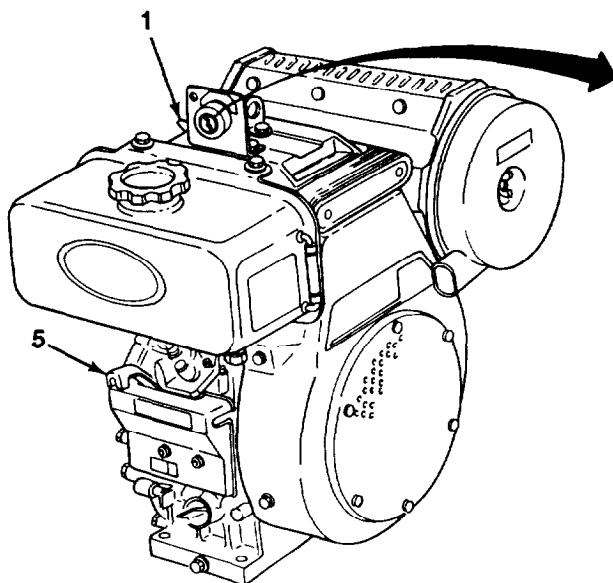
- (1) Set speed control lever (5) to HIGH START position. Insert key (3) in starter switch (2).

**NOTE**

If ambient temperature is below 41°F (5°C), perform steps a(2) and a(3).

- (2) Turn starter switch (2) to GL position and leave for approximately five seconds. Push decompression lever (1).

- (3) Turn starter switch (2) to ST position for 1-2 seconds. Release decompression lever (1).



---

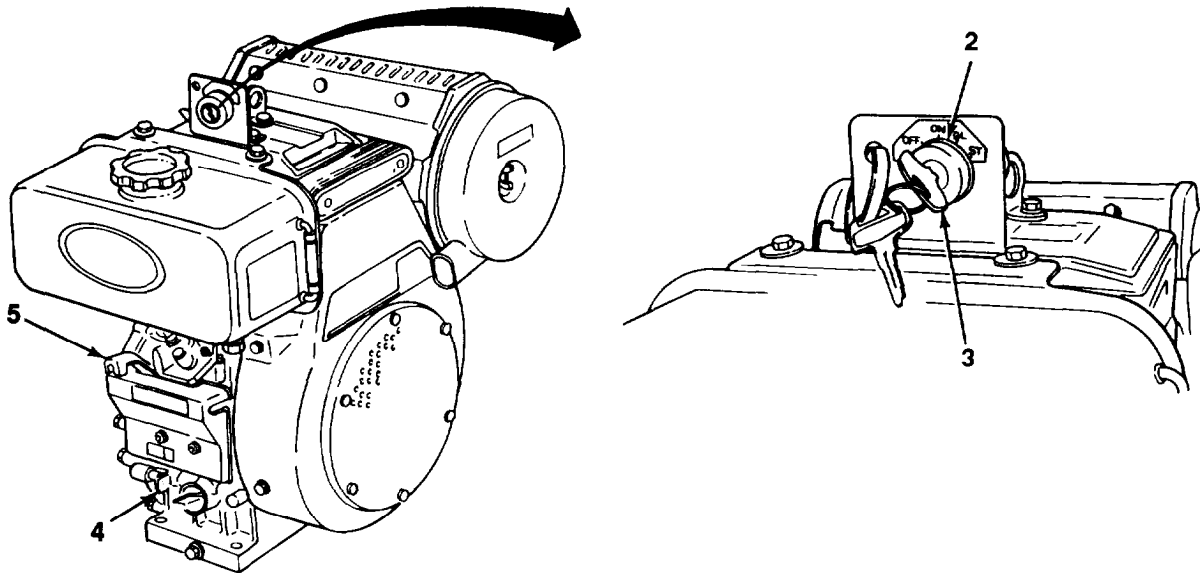
## 2-20. OPERATING ENGINE (Con't).

---

### NOTE

If engine is being started for first time and is fully cooled, use of decompression lever may be required.

- (4) Turn starter switch (2) to ST position. When engine starts, release starter switch.
- (5) Set speed control lever (5) to LOW position. Idle engine for three minutes to warm engine.
- (6) Set speed control lever (5) to HIGH START position when operating hydraulic control valve.



### b. Shutting Down Engine.

- (1) Before shutdown, set speed control lever (5) to LOW position and idle engine for three minutes.
- (2) Push stop lever (4) to the right to STOP position.
- (3) As soon as engine stops, turn starter switch (2) to OFF position. Remove key (3).

---

**2-21. OPERATING HYDRAULIC CONTROL VALVE**


---

**NOTE**

This paragraph contains general instructions on operating the hydraulic control valve as well as specific instructions on operating the hydraulic control valve to place the dolly set in a variety of configurations.

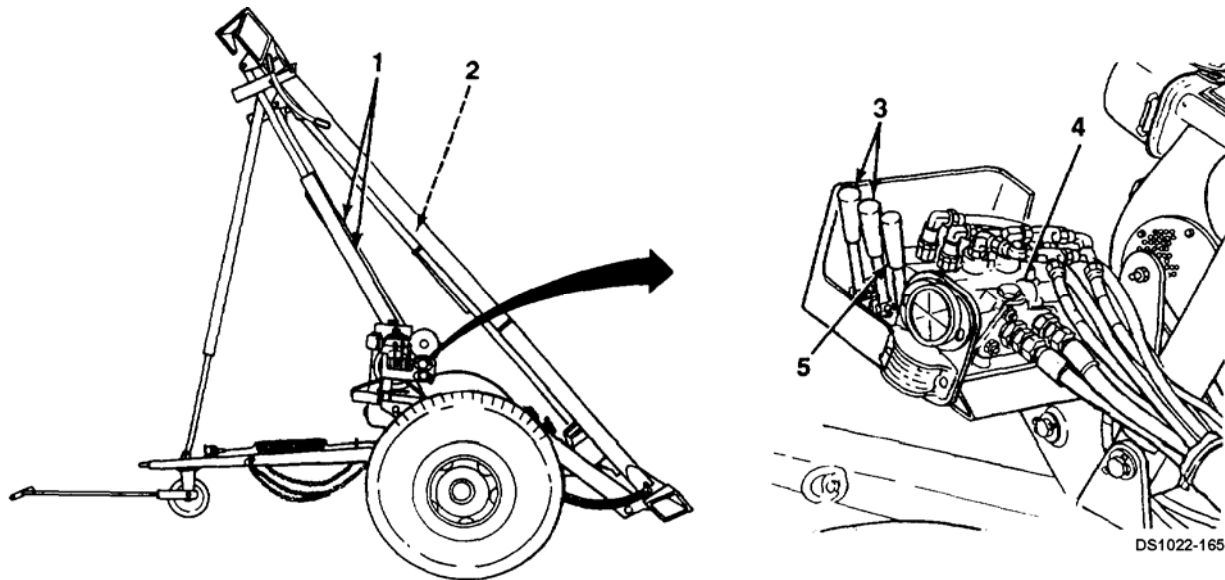
**a. General.**

(1) The hydraulic control valve (4) is located on the left side of each dolly half. It has three levers (3 and 5) which regulate hydraulic fluid flow to operate the lift cylinders (1) and positioning cylinders (2).

**CAUTION**

**DO NOT extend or retract a lift cylinder more than 12 in. (30 cm) more than other lift cylinder on dolly half or structural damage to dolly set will occur.**

(2) Two three-position (RETRACT, NEUTRAL, EXTEND) lift cylinder levers (3) operate the lift cylinders (1). They may be operated separately or in unison as required. Unless operating on uneven terrain, it is best to operate levers in unison. If operated separately, DO NOT extend or retract a lift cylinder more than 12 in. (30 cm) more than other lift cylinder on dolly half.



(3) One four-position (FLOAT, RETRACT, NEUTRAL, EXTEND) positioning cylinders lever (5) operates the positioning cylinders (2) in unison.

(4) All levers (3 and 5) are in NEUTRAL position when not being operated.

(5) When the levers (3 and 5) are pushed up, the affected cylinders retract. When pulled down, the affected cylinders extend..

---

## 2-21. OPERATING HYDRAULIC CONTROL VALVE (Cont).

---

(6) The positioning cylinders lever (5) has a fourth position-FLOAT. When in FLOAT position, the positioning cylinders (2) work in unison with the lift cylinders (1) as the lift cylinder levers (3) are operated. To engage this position, quickly push up on positioning cylinders lever beyond the RETRACT position. Once in FLOAT position, the lever will remain in FLOAT until pulled back down to NEUTRAL position.

**b. Placing Dolly Half in Maneuvering Position.**

**WARNING**

**DO NOT** operate control valve levers to put front or rear dolly in maneuvering position unless telescopic brace and front axle steering locking pin are installed. Telescopic brace and front axle steering locking pin must **ALWAYS** be installed before lift cylinders reach their vertical position. Failure to follow this warning may cause front or rear dolly to overturn, resulting in serious injury or death to personnel.

**CAUTION**

Use extreme caution to ensure that near (left side) top beam vertical tube does not contact control valve and fittings and cause damage when placing dolly half in maneuvering position. Carefully follow all steps and monitor position of lift cylinders and pivoting tray to guard against binding and interference.

**NOTE**

- The maneuvering position is a three-wheel configuration. The dolly half's center of gravity is shifted over the axle, the top beam is resting over the drawbar, and the axle.
- Before proceeding, ensure that all stowed items such as rear drawbar, ladder, and intradolly air hoses and cable have been removed; air bags must be deflated; transportation lockouts have been secured to top beam vertical tubes with stowage straps; and toolbox has been closed (see paragraph 2-8).
- The following steps are performed at the front and/or rear dolly as required. Procedure begins with bottom beam resting on ground with top and bottom beams vertical and engines running at high idle.

(1) Ensure that front axle steering locking pin is installed to lock steering (see paragraph 2-7). Ensure that telescopic braces are installed (see paragraph 2-8).

(2) Pull down on positioning cylinders lever (5) to extend positioning cylinders (2) until telescopic brace (12) reaches rest pin (11).

(3) Quickly push up on positioning cylinders lever (5) to FLOAT position.



---

**2-21. OPERATING HYDRAULIC CONTROL VALVE (Cont).**


---

**CAUTION**

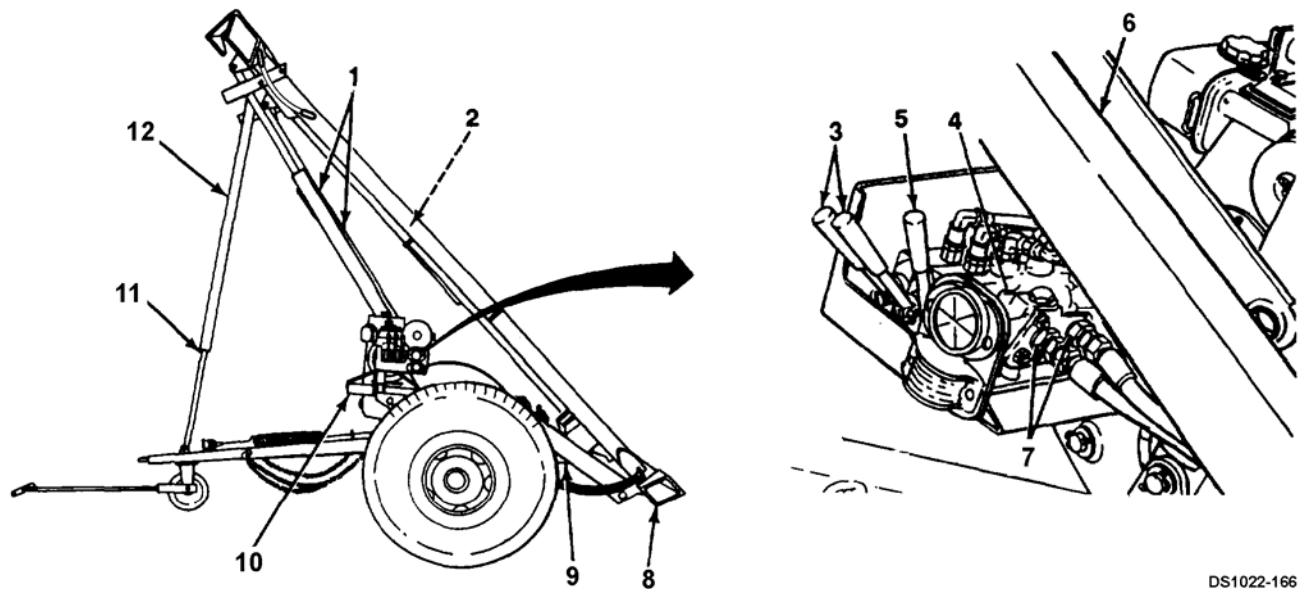
Proceed slowly and with caution to prevent equipment damage.

**NOTE**

**If operating a dolly half equipped with side lift kit, extension of lift and positioning cylinders should stop when top beam vertical tubes have extended approximately 49 in. (124 cm) and positioning cylinder limit lines are just visible.**

(4) Pull down on two lift cylinder levers (3) to extend lift cylinders (1) and positioning cylinders (2). Stop when near (left side) top beam vertical tube (6) reaches within  $\frac{1}{2}$  in. (13 mm) of hydraulic control valve (4) and fittings (7).

(5) Continue to pull down on two lift cylinder levers (3), allowing near (left side) lift cylinder (1) to lead far (right side) lift cylinder. Maintain clearance of  $\frac{1}{2}$  in. (13 mm).



DS1022-166

(6) If operating a dolly half equipped with side lift kit, return positioning cylinders lever (5) to NEUTRAL position.

(7) Continue to pull down on two lift cylinder levers (3) until bottom beam (8) is raised off the ground and axle (9) and pivoting tray (10) are parallel to the ground. Dolly half is now in maneuvering position and axle (9) and pivoting tray (10) are parallel to the ground. Dolly half is now in maneuvering position.

**WARNING**

**While in maneuvering position, DO NOT operate positioning cylinders lever. Failure to follow this warning may cause bottom beam to lower to the ground, causing serious injury to personnel.**

(8) Return positioning cylinders lever (5) to NEUTRAL position, as required.

2-21. OPERATING HYDRAULIC CONTROL VALVE (Cont).

c. Removing Dolly Half From Maneuvering Position.

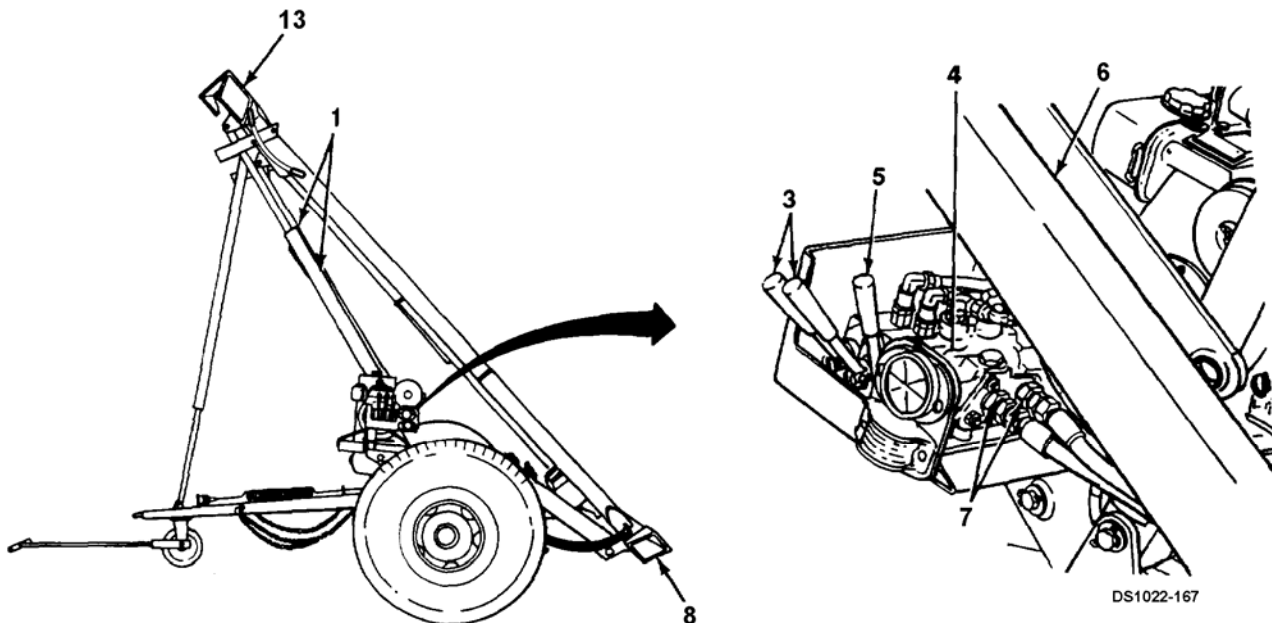
**CAUTION**

Use extreme caution to ensure that near (left side) top beam vertical tube does not contact control valve and fittings and cause damage when removing dolly half from maneuvering position. Carefully follow all steps and monitor position of lift cylinders and pivoting tray to guard against blinding and Interference.

**NOTE**

The following steps are performed at the front and/or rear dolly as required. When procedure has been completed, bottom beam will be resting on ground with top and bottom beams vertical.

- (1) Push up on two lift cylinder levers (3) to retract lift cylinders (1). Stop when near (left side) top beam vertical tube (6) reaches within ½ in. (13 mm) of hydraulic control valve (4) and fittings (7).
- (2) Continue to push up on two lift cylinder levers (3), allowing far (right side) lift cylinder (1) to lead near (left side) lift cylinder. Maintain clearance of ½ in. (13 mm).
- (3) Continue to push up on two lift cylinder levers (3) until bottom beam (8) rests on ground.
- (4) Quickly push up on positioning cylinders lever (5) to FLOAT position.
- (5) Push up on lift cylinder levers (3) to retract lift cylinders (1) until approximately 6 in. (15 cm) of stroke remain on lift cylinders.
- (6) Return positioning cylinders lever (5) to NEUTRAL position.
- (7) Push up on positioning cylinders lever (5) until top and bottom beams (13 and 8) are vertical.



DS1022-167

---

**2-21. OPERATING HYDRAULIC CONTROL VALVE (Cont).**

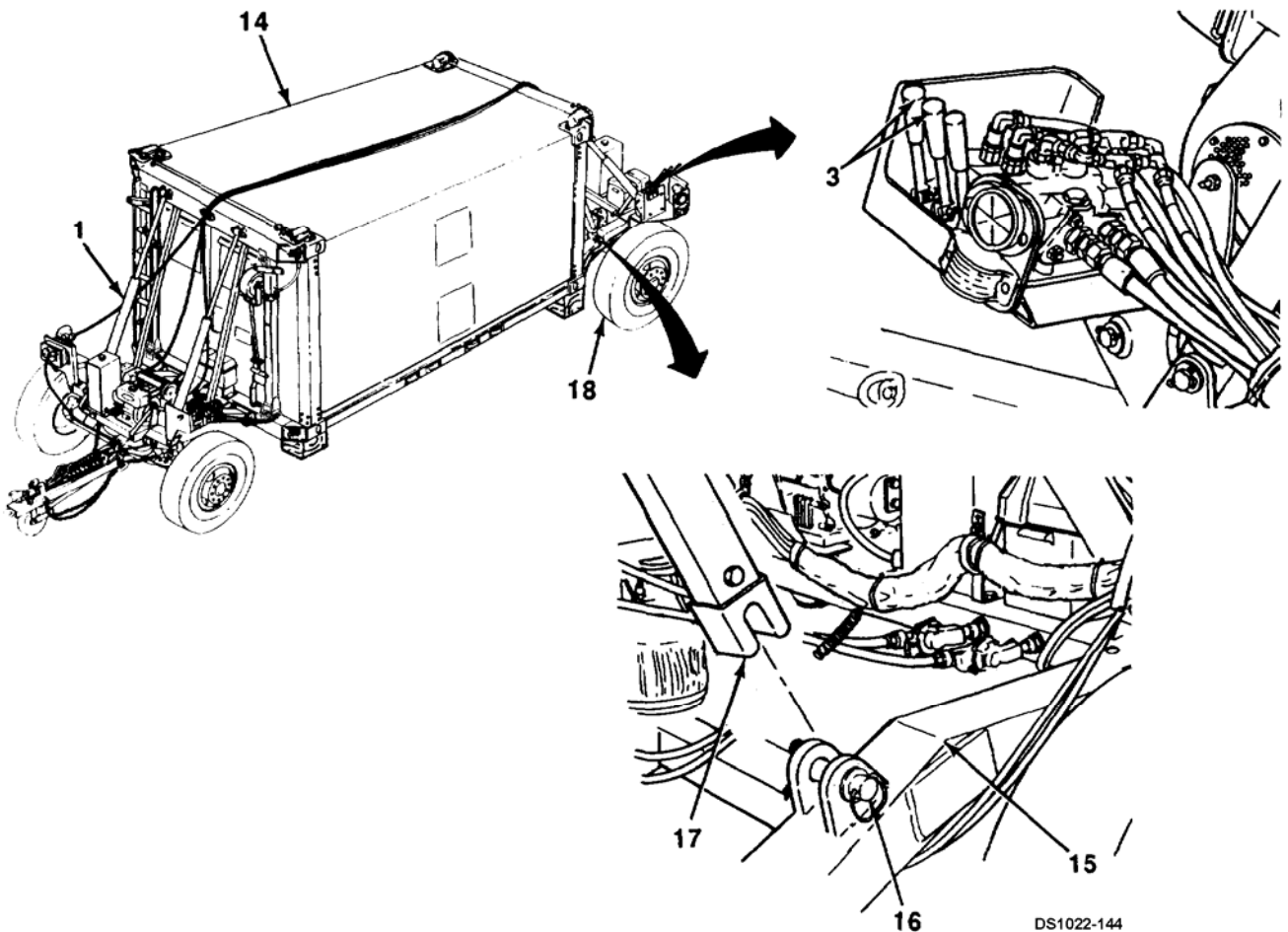

---

**NOTE**

Perform subparagraphs d and e when changing a wheel and tire using dolly set hydraulic system Instead of a floor jack or towing vehicle jack.

**d. Raising Wheel and Tire Off Ground.****(1) Dolly Set With Shelter.**

- (a) Place two 4 x 4s or similar support under each corner of shelter (14).
- (b) At front and rear dollies, pull down on two lift cylinder levers (3) to slightly extend lift cylinders (1). Disengage transportation lockouts (17) from hitch pins (16) at suspension links (15).



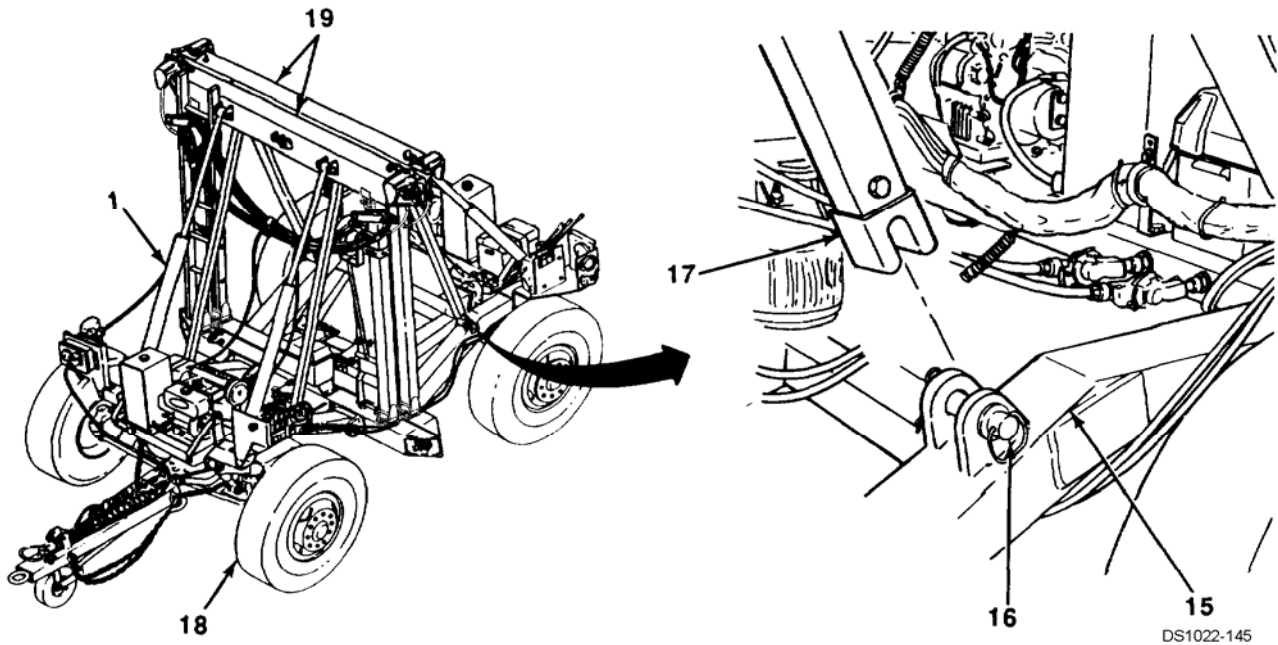
- (c) At affected end, push up on two lift cylinder levers (3) to lower shelter (14) onto supports.
- (d) Continue to push up on lift cylinder levers (3) until wheels and tires (18) come off the ground.
- (e) Support axle during wheel and tire Change.

DS1022-144

**2-21. OPERATING HYDRAULIC CONTROL VALVE (Cont).**

**(2) Dolly Set Without Shelter.**

- (a) At front and rear dollies, pull down on two lift cylinder levers (3) to slightly extend lift cylinders (1). Disengage transportation lockouts (17) from hitch pins (16) at suspension links (15).



DS1022-145

- (b) At front and rear, push up on two lift cylinder levers (3) to lower dolly set to the ground.
- (c) At front and rear, quickly push up on positioning cylinders lever (5) to FLOAT position.
- (d) At front and rear, pull down on two lift cylinder levers (3) to extend top beams (19). Stop when 1.5-2.0 ft (0.5-0.6 m) of bottom beam vertical tube (20) is exposed and lift cylinders (1) at affected end are vertical.
- (e) At front and rear, return positioning cylinders lever (5) to NEUTRAL position.
- (f) At affected end, push up on two lift cylinder levers (3) until wheels and tires (18) come off ground.
- (g) Support axle during wheel and tire Change.

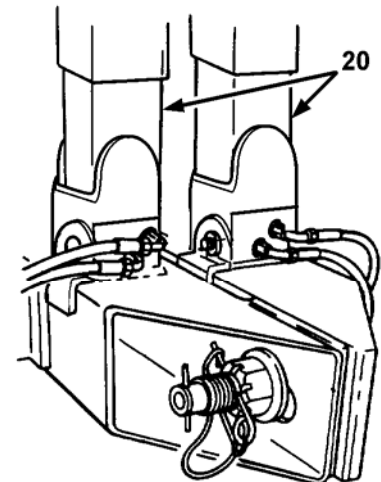
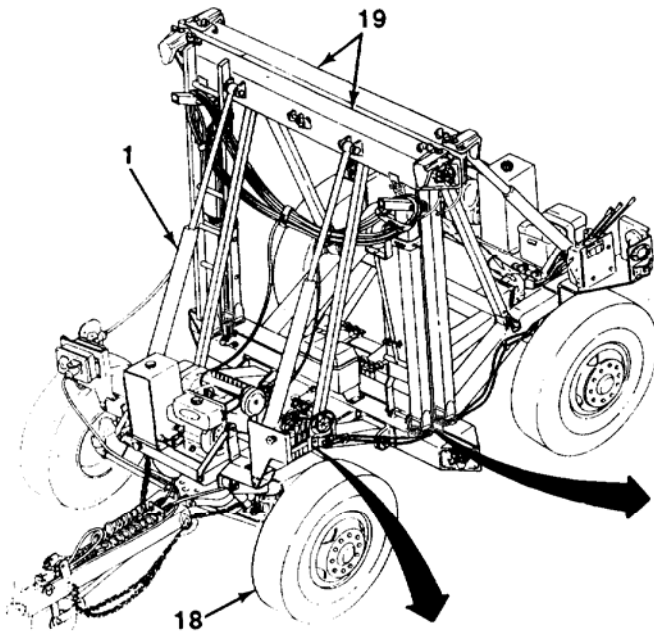
---

**2-21. OPERATING HYDRAULIC CONTROL VALVE (Cont).**

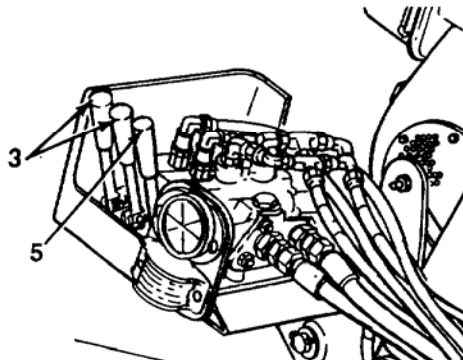

---

**e. Lowering Wheel and Tire to Ground.****(1) Dolly Set Without Shelter.**

- (a) Remove axle support.
- (b) At affected end, pull down on lift cylinder levers (3) to extend lift cylinders (1) until wheels and tires (18) are lowered to the ground.
- (c) At front and rear, quickly push up on positioning cylinders lever (5) to FLOAT position.
- (d) At front and rear, push up on two lift cylinder levers (3) to fully retract lift cylinders (1).
- (e) At front and rear, return positioning cylinders lever (5) to NEUTRAL position.
- (f) At front and rear, pull down on two lift cylinder levers (3) to raise dolly set to a sufficient height to allow engagement of two transportation lockouts (17).
- (g) At front and rear, engage two transportation lockouts (17) on hitch pins (16) at suspension links (15).



DS1022-146



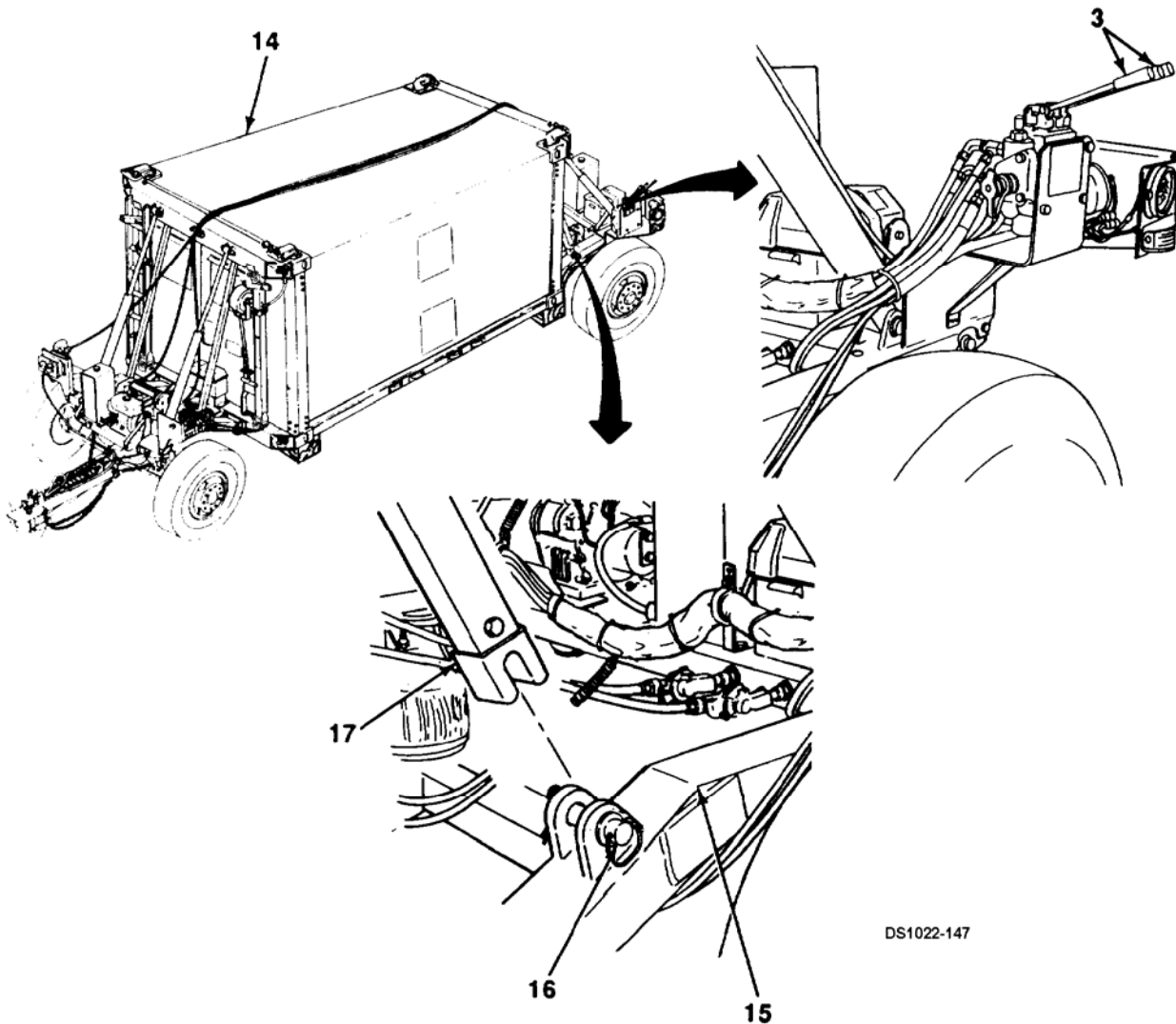
---

## 2-21. OPERATING HYDRAULIC CONTROL VALVE (Cont).

---

### (2) Dolly Set With Shelter.

- (a) Remove axle support.
- (b) At affected end, pull down on two lift cylinder levers (3) to raise shelter (14) off supports to a sufficient height to allow engagement of two transportation lockouts (17).
- (c) At front and rear, engage two transportation lockouts (17) on hitch pins (16) at suspension links (15).
- (d) Remove 4 x 4s or similar support from corners of shelter (14)



DS1022-147

---

## 2-22. INFLATING AIR BAGS.

---

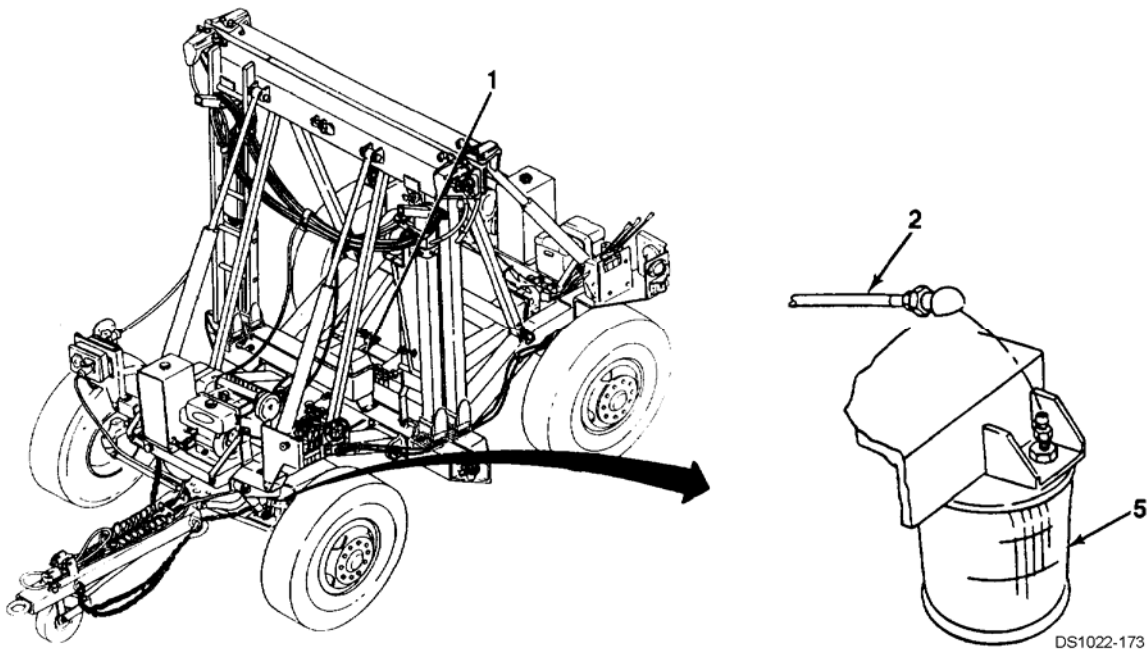
### a. General

**CAUTION**

**Ensure that air bag valve is capped when not in use. If cap is not installed, dirt can enter valve and cause air bag to lose air.**

(1) The dolly set has four air bags (5) which must be properly inflated before towing operations can begin. Whenever possible, air to inflate air bags is supplied by the towing vehicle.

(2) The charging assembly (2) (Item 1, Appendix D) is used to inflate air bags (5). It is stowed in toolbox (1) when not in use.



**CAUTION**

**If air is used from a source other than the towing vehicle, air bag pressure should not exceed 120 psi (827 kPa). Failure to follow this caution may damage air bags.**

- (3) Before the dolly set is raised, air bags (5) should be inflated.
- (a) For a dolly set with shelter, inflate air bags (5) until air stops flowing.
  - (b) For a dolly set without shelter, inflate air bags (5) for a full ten seconds, then stop.

## 2-22. INFLATING AIR BAGS (Cont).

(4) Once raised, air bags (5) are deflated until top portion of each shock absorber (7) reaches level of ride height indicator ring (6).

(5) Shelters with offcenter loads should be leveled by deflating air bags (5) on the lighter side.

### b. Inflating Air Bags.

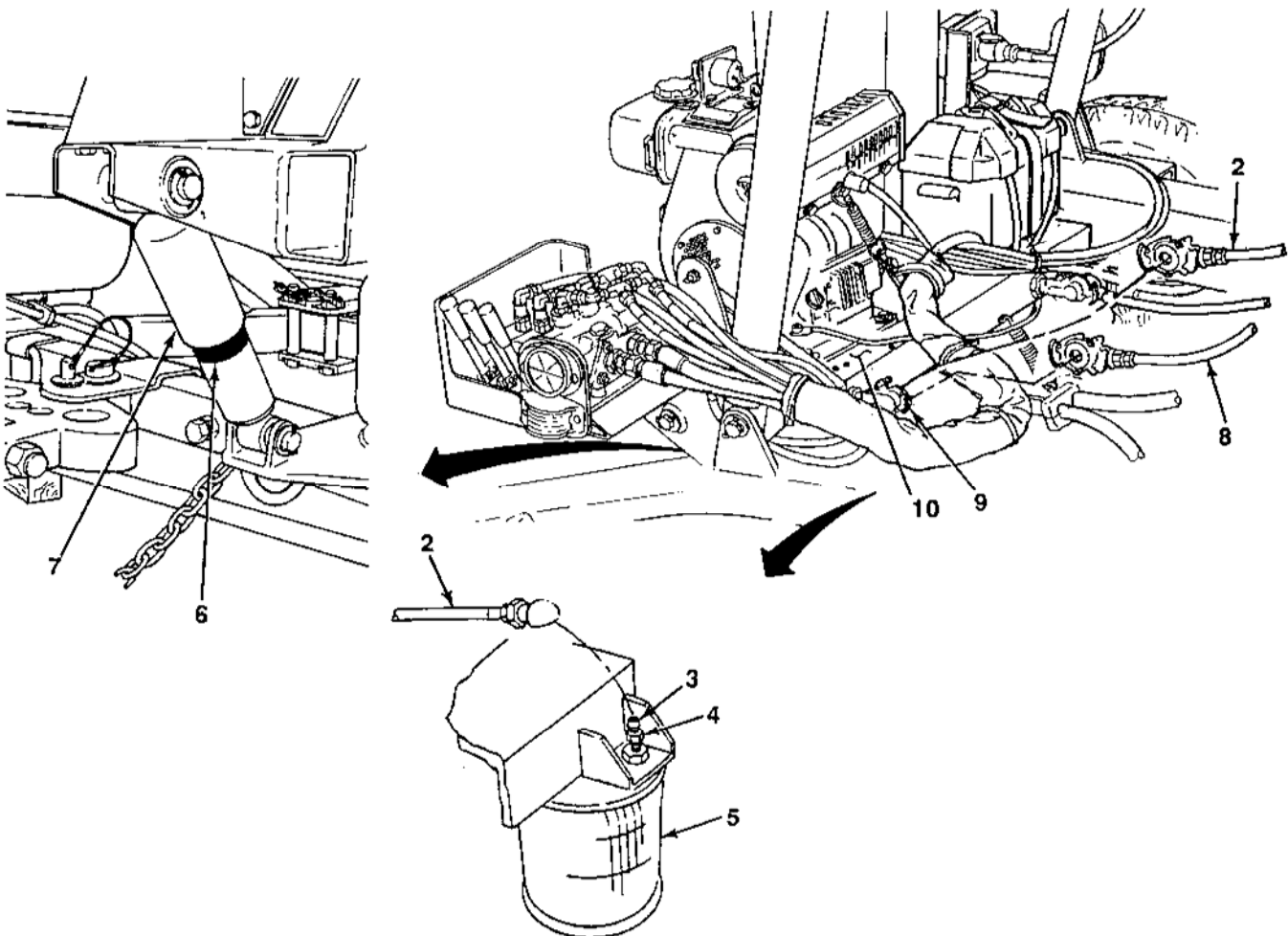
#### NOTE

**Procedures to inflate air bags in preparation for towing either a single dolly set, with or without shelter, or dolly sets in tandem are similar. Differences will be identified as they occur**

(1) Ensure that emergency air valve at rear of towing vehicle is closed (see towing vehicle Operator's Manual).

(2) At left rear of front dolly pivoting tray (10), disconnect intradolly emergency air hose (8) from emergency (red) gladhand (9).

(3) Connect charging assembly (2) (Item 1, Appendix D) to emergency (red) gladhand (9).



DS1022-179



---

**2-22. INFLATING AIR BAGS (Con't).**


---

## NOTE

If inflating air bags on a rear dolly set when tandem towing, ensure that emergency shutoff valve at rear of front dolly set is open.

- (4) Open emergency air valve at rear of towing vehicle (see towing vehicle Operator's Manual).

**CAUTION**

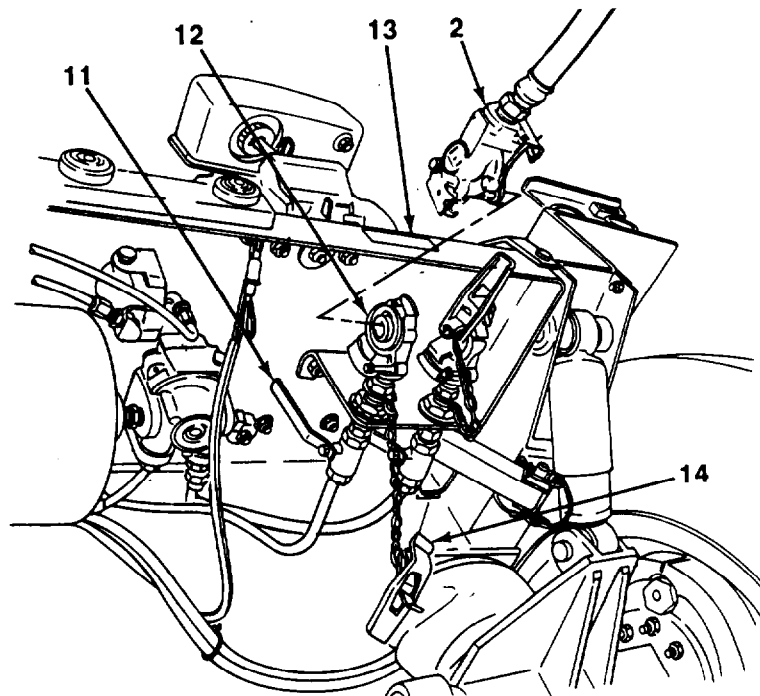
If air is used from a source other than the towing vehicle, air bag pressure should not exceed 120 psi (827 kPa). Failure to follow this caution may damage air bags.

(5) Remove two caps (3) from air bag valves (4). Using charging assembly (2) (Item 1, Appendix D), inflate two air bags (5) on front dolly either until air stops flowing (dolly set with shelter) or for a full ten seconds (dolly set without shelter). Install caps on air bag valves.

## NOTE

If inflating air bags on a rear dolly set when tandem towing, ensure that emergency shutoff valve at rear of front dolly set is closed.

- (6) Close emergency air valve at rear of towing vehicle (see towing vehicle Operator's Manual).
- (7) Disconnect charging assembly (2) from emergency (red) gladhand (9) and connect intradolly emergency air hose (8).
- (8) Remove dummy coupling (14) and connect charging assembly (2) to emergency (red) gladhand (12) under rear dolly pivoting tray (13).
- (9) Open emergency shutoff valve (11).

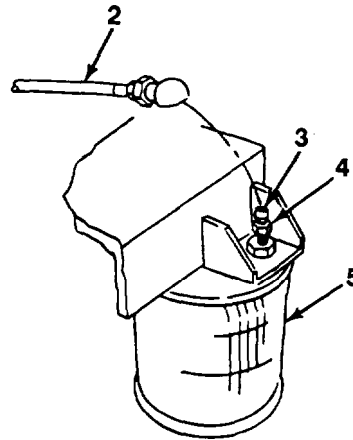


**2-22. INFLATING AIR BAGS (Con't).**

**CAUTION**

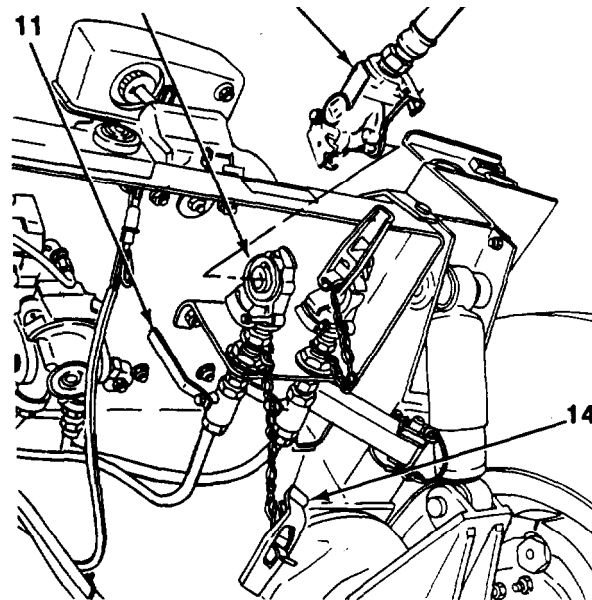
If air is used from a source other than the towing vehicle, air bag pressure should not exceed 120 psi (827 kPa). Failure to follow this caution may damage air bags.

(10) Remove two caps (3) from air bag valves (4). Using charging assembly (2) (Item 1, Appendix D), Inflate two air bags (5) on rear dolly either until air stops flowing (dolly set with shelter) or for a full ten seconds (dolly set without shelter). Install caps on air bag valves.



(11) Close emergency shutoff valve (11). Disconnect charging assembly (2) from emergency (red) gladhand (12) and install dummy coupling (14).

(12) Stow charging assembly (2) in toolbox.



**NOTE**

If inflating air bags on a rear dolly set when tandem towing, ensure that service and emergency shutoff valves at rear of front dolly set are open.

(13) Open both service and emergency air valves on towing vehicle. Fully pressurize dolly set air-brake system (see towing vehicle Operator's Manual).

**Section IV. OPERATION UNDER UNUSUAL CONDITIONS**

Paragraph Number	Paragraph Title	Page Number
2-23.	General . . . . .	2-143
2-24.	Operation in Extreme Cold or Snow . . . . .	2-143
2-25.	Operating Engine In Extreme Cold [Below 0°F (-18°C)] . . . . .	2-144
2-26.	Operation In Extreme Heat . . . . .	2-145
2-27.	Operation in Mud . . . . .	2-145
2-28.	Operation in Saltwater Areas . . . . .	2-145
2-29.	Operation in Areas of High Humidity and Heavy Rain . . . . .	2-146
2-30.	Operation in Sandy or Dusty Areas . . . . .	2-146
2-31.	Operation on Rough or Rocky Terrain . . . . .	2-146
2-32.	Operation on Uneven Terrain . . . . .	2-146
2-33.	Fording Operations . . . . .	2-149
2-34.	Redundant Power Operation . . . . .	2-150

---

**2-23. GENERAL.**

---

a. This section contains instructions for safely operating the M1022A1 Dolly Set under unusual conditions. In addition to normal preventive maintenance, special care must be taken to keep the dolly set operational in extreme temperatures and other environmental conditions.

b. Refer to FM 21-305 and FM 55-30 for information on special driving instructions under unusual conditions.

---

**2-24. OPERATION IN EXTREME COLD OR SNOW.**

---

a. Special care must be taken when operating the dolly set In cold weather. Refer to FM 9-207 for operation and maintenance of ordnance materiel in cold weather. Also refer to FM 21-305 for special instructions on operating In snow.

b. Care must be taken when placing the dolly set in motion after shutdown. Thickened lubricants may cause failure of components.

c. Refer to Chapter 3, Section I for proper lubrication during extreme cold weather.

d. Care must be taken when handling electrical cables. Extreme cold weather can cause Insulation material on electrical wire to crack, causing short circuits. Components may become hard or brittle and easily damaged or broken.

e. When parking for any period of time in temperatures below 0°F (-18°C), park in a sheltered area out of the wind and clean off any buildup of ice or snow. Place footing of planks or brush under tires to prevent them from freezing to the ground. Ensure that tires are properly inflated (see paragraph 1-15). Underinflated tires will freeze, resulting in flat spots.

---

2-25. OPERATING ENGINE IN EXTREME COLD [BELOW 0°F (-18°C)].

---

**WARNING**

- Carbon monoxide can be deadly. DO NOT operate engine In enclosed areas. Good ventilation is essential. Failure to follow this warning may result in serious Injury or death to personnel.
- Always wear ear plugs or other types of hearing protection while engine Is running. Damage to hearing will occur without protection.

NOTE

- Before operating engine In extreme cold [below 0°F (-18°C)], ensure that Unit Maintenance has winterized engine and checked for a fully charged battery with securely connected battery cables.
- If temperature Is -26°F to -50°F (-32°C to -46°C), cold start kit, installed by Unit Maintenance, must be used to jump start the dolly set engines (see subparagraph c.).

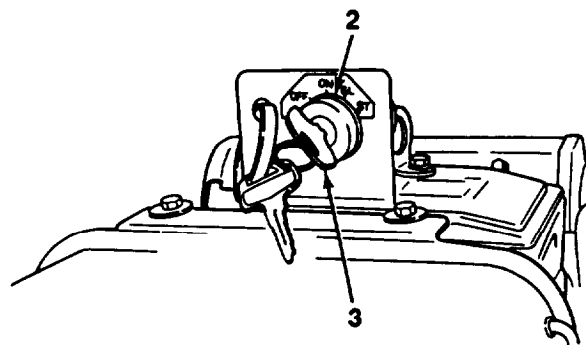
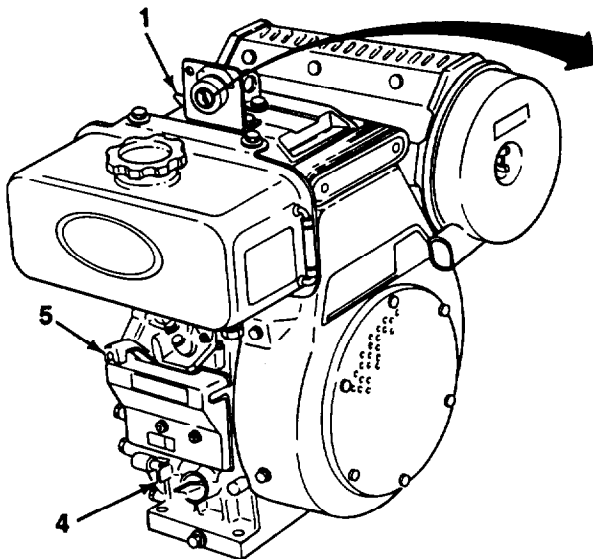
a. Starting Engine.

NOTE

To reduce engine load, ensure that all hydraulic control valve levers are In NEUTRAL position.

(1) Set speed control lever (5) to HIGH START position. Insert key (3) in starter switch (2).

(2) Turn starter switch (2) to GL position. Leave for three minutes if temperatures are 0°F to -25°F (-18°C to -32°C). Leave in GL position for four minutes if temperatures are below -25°F (-32°C).



---

**2-25. OPERATING ENGINE IN EXTREME COLD [BELOW 0°F (-18°C)] (Con't).**

---

(3) Raise decompression lever (1) and begin cranking by turning starter switch (2) to ST position. After five seconds of cranking, lower decompression lever (1).

(4) Continue cranking until black smoke (indicating combustion) is seen in exhaust or until engine runs without aid of starter. If engine starts but white smoke (indicating fuel) is seen, continue to crank. Engine should start within 20 seconds.

(5) After engine starts, turn starter switch (2) to GL position and leave for 30 seconds.

(6) Turn starter switch (2) to ON position. Set speed control lever (5) to LOW position, Idle engine for a minimum of five minutes or until engine runs smoothly.

(7) Set speed control lever (5) to HIGH START position when operating hydraulic control valve.

**b. Shutting Down Engine.**

(1) Before shutdown, set speed control lever (5) to LOW position and idel engine for three minutes.

(2) Push stop lever (4) to the right to STOP position.

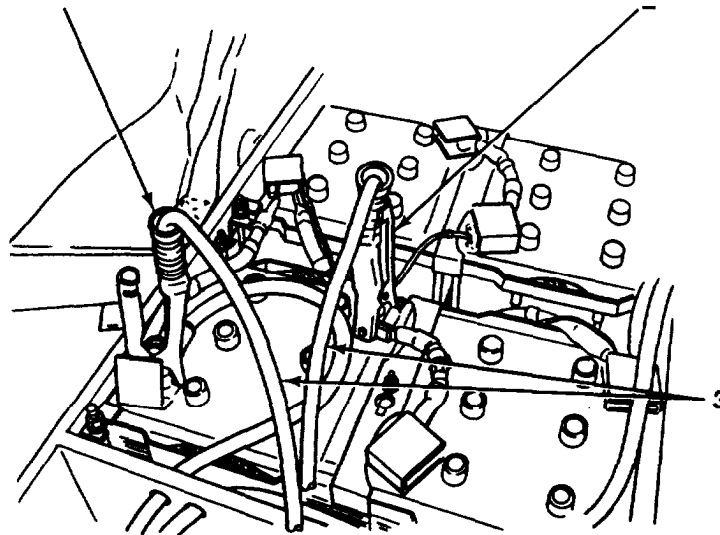
(3) As soon as engine stops, turn starter switch (2) to OFF position. Remove key (3).

**c. Jump Starting Using Cold Start Kit (-26°F to -50°F (-32% to -46%)).**

(1) Attach jumper cable (3) to 12-volt battery in towing vehicle:

(a) Attach positive (red) alligator clip (2) to positive (+) battery terminal

(b) Attach negative (black) alligator clip (1) to negative (-) battery terminal.

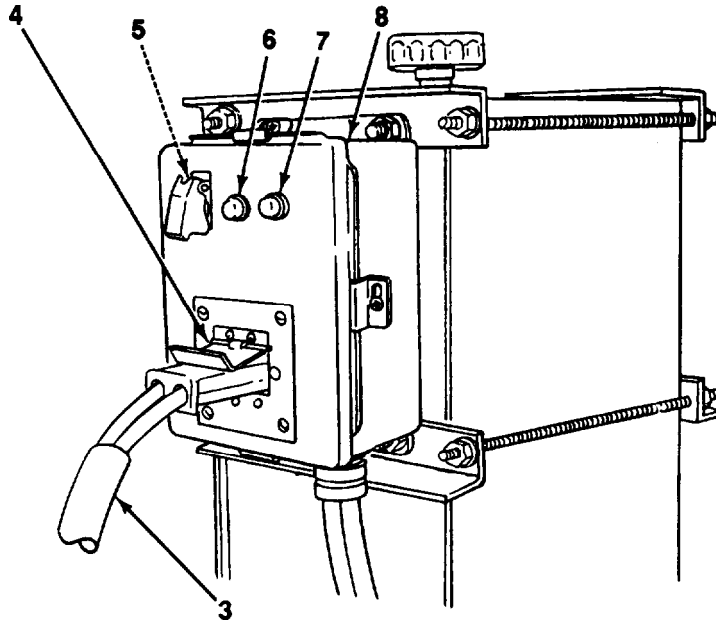


---

**2-25. OPERATING ENGINE IN EXTREME COLD [BELOW 0°F (-18°C)] (Con't).**

---

- (2) Connect jumper cable (3) to socket (4) on enclosure assembly (8).



(3) If hookup is correct, green light (7) will illuminate. If red light (6) illuminates, connection to battery is incorrect. Repeat step (1).

- (4) Place switch (5) up to ON position.  
(5) Start towing vehicle engine.

NOTE

With cold start kit installed and jumper cable connected to a running towing vehicle, multiple starting attempts can be accomplished.

- (6) Start dolly half engine (see subparagraph a).

---

**2-26. OPERATION IN EXTREME HEAT.**

---

- a. Refer to Chapter 3, Section I for proper lubrication during extreme heat conditions.
- b. Avoid parking dolly set in sunlight for long periods of time. Heat and sunlight shorten tire life.
- c. Shelter or cover dolly set with canvas, if available.
- d. Ensure that tires are Inflated to proper pressure (see paragraph 1-15).

---

**2-27. OPERATION IN MUD.**

---

- a. If one or more wheels sink into mud, it may be necessary to raise sunken wheel(s) and place planking or matting under it.
- b. If tactical situation permits, immediately after operation in mud, thoroughly clean, inspect, and lubricate (see Chapter 3, Section I).
- c. Have Unit Maintenance pack wheel bearings as required.

---

**2-28. OPERATION IN SALTWATER AREAS.**

---

Saltwater causes rapid rust and corrosion to develop. Clean, inspect, and lubricate as soon as possible after operation in saltwater areas (see Chapter 3, Section I). Have Unit Maintenance pack wheel bearings contaminated by saltwater as soon as possible.

---

## **2-29. OPERATION IN AREAS OF HIGH HUMIDITY AND HEAVY RAIN.**

---

a. Dolly sets, inactive for long periods of time In hot and humid weather, are subject to rapid rusting and accumulation of fungus. Inspect, clean, and lubricate to prevent deterioration of painted surfaces. Refer to Lubrication Instructions (see Chapter 3, Section I).

b. Dampness increases chances of corrosion. Inspect all surfaces and electrical connections for signs of corrosion (see paragraph 1-9).

---

## **2-30. OPERATION IN SANDY OR DUSTY AREAS.**

---

a. Clean, inspect, and lubricate the dolly set more often when operating in sandy or dusty areas (see Chapter 3, Section I).

b. Clean engine air cleaner element daily when operating in sandy or dusty areas (see paragraph 3-10).

c. Maintain proper tire pressure (see paragraph 1-15).

---

## **2-31. OPERATION ON ROUGH OR ROCKY TERRAIN.**

---

a. Tires must be fully Inflated to 110 psi (758 kPa). Underinflation will cause Internal ruptures of tires and damage to tubes.

b. Before attempting to drive over stumps or rocks, ensure that the dolly set can clear them. Stumps and rocks can damage components on the underside of the dolly set.

---

## **2-32. OPERATION ON UNEVEN TERRAIN.**

---

a. General.

(1) The dolly set is designed to be able to attach to a shelter when on uneven terrain [shelter and dolly set have up to a 12 in. (30 cm) difference in level or one wheel is 12 in. (30 cm) lower than the other wheel on the same axle].

(2) To compensate for the uneven condition, the axle-to-pivot axle bracket coupling Is unlocked. This allows the coupling to pivot on the dolly half that has uneven terrain.

(3) The pivoting tray lockout brace on the dolly half that is on uneven terrain must also be unlocked.

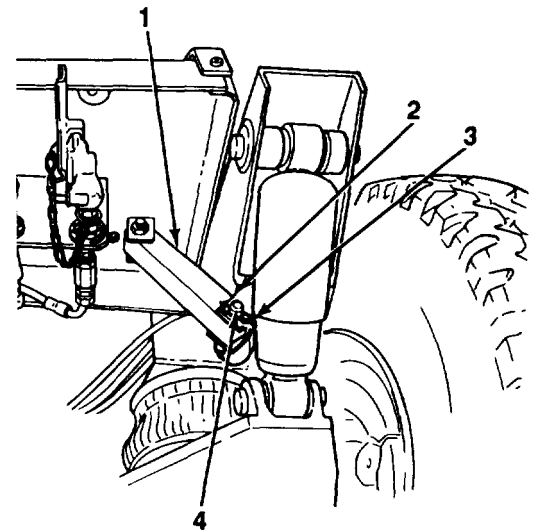


**2-21. OPERATING ON UNEVEN TERRAIN (Cont).**

**b. Operating on Uneven Terrain.**

(1) Follow instructions in paragraph 2-9 or 2-10 to position each dolly half where desired.

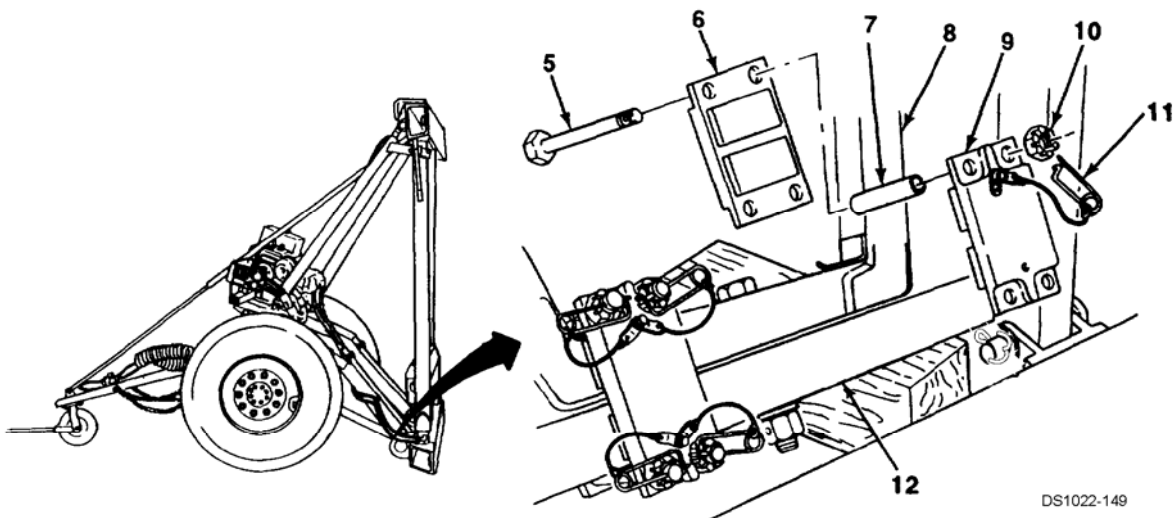
(2) Remove safety pin (3) and hitch pin (4) and unlock pivoting tray lockout brace (1) from lower bracket (2).



(3) Once in position, remove each dolly half from maneuvering position with bottom beam resting on the ground (see paragraph 2-21).

(4) Remove eight safety pins (11) from bolts (5).

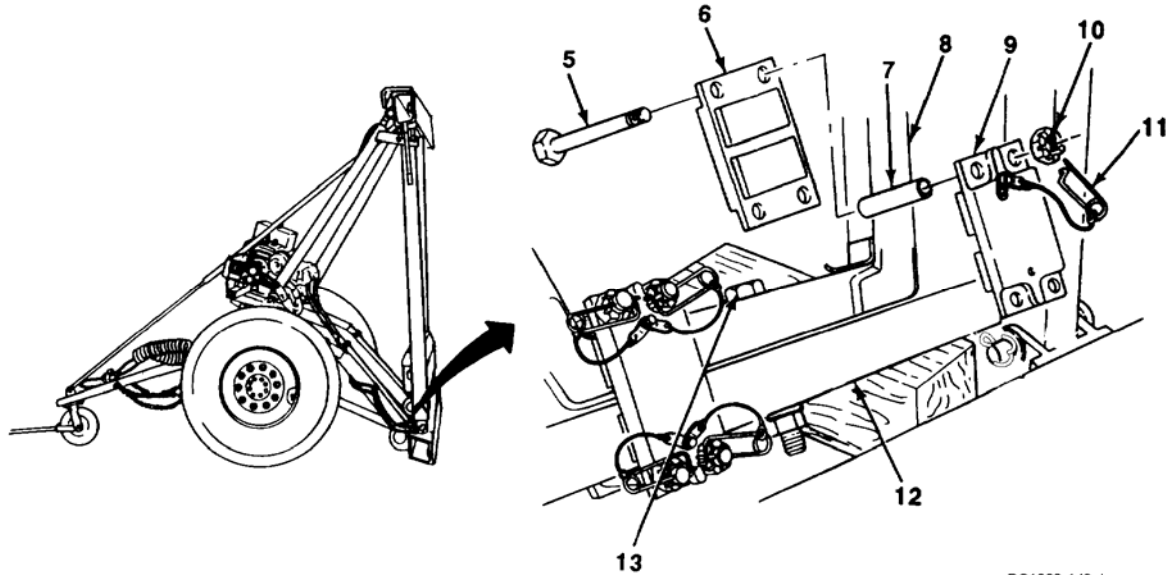
(5) Remove four nuts (10), bolts (5) bottom lockout bracket (6) four sleeves (7), and top lockout bracket (9) from each end of axle (8) and pivot axle bracket (12).



DS1022-149

**2-21. OPERATING ON UNEVEN TERRAIN (Cont).**

(6) Reinstall each lockout bracket assembly (15) to center on either side of pivot bolt (13). Wrap stowage strap (14) around lockout bracket assemblies to restrain.



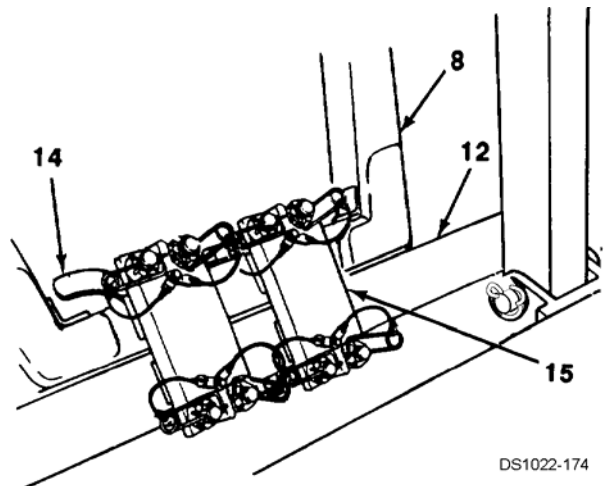
**CAUTION**

**DO NOT extend or retract a lift cylinder more than 12 in. (30 cm) more than other lift cylinder on dolly half or structural damage to dolly set will occur.**

(7) When positioning top and bottom beams for attachment to shelter, operate lift cylinder levers independently, as required, to compensate for the uneven terrain (see paragraph 2-21).

(8) Once attached to shelter, operate lift cylinder levers independently to raise shelter and level it (see paragraph 2-21).

(9) (9) Operate lift cylinder levers to bring axle (8) and pivot axle bracket (12) level with each other (see paragraph 2-21).



---

## 2-32. OPERATION ON UNEVEN TERRAIN (Con?).

(10) Remove stowage strap (14). Repeat step (5) to remove lockout bracket assemblies (15) from position at midpoint of axle (8) and pivot axle bracket (12).

### NOTE

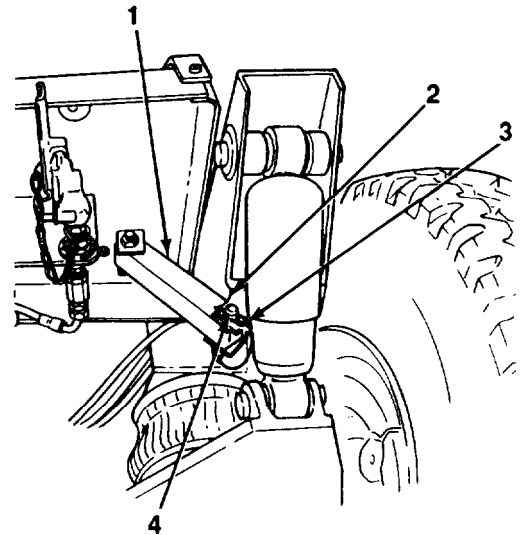
Welded pads on axle and pivot axle bracket Identify correct Installation location of lockout bracket assemblies.

(11) Install top lockout bracket (9), four sleeves (7), bottom lockout bracket (6) four bolts (5), and nuts (10) on each end of axle (8) and pivot axle bracket (12). Handtighten nuts.

(12) Wrench tighten nuts 1 ¼ to 2 flats.

(13) Install safety pins (11) through bolts (5) to secure nuts (10).

(14) Lock pivoting tray lockout brace (1) to lower bracket (2) with hitch pin (4) and safety pin (3).




---

## 2-33. FORDING OPERATIONS.

---

### NOTE

The dolly set, with or without shelter, can hardbottom ford either freshwater or saltwater up to a depth covering the wheel hubs.

a. After fording, apply the brakes a few times to help dry the brake linings. Ensure that the brakes are operating properly before driving at normal speeds.

### NOTE

If dolly Set was required to ford water that covered the wheel hubs, have Unit Maintenance check, clean, and lubricate wheel bearings.

b. Lubricate the dolly set in accordance with Instructions in Chapter 3, Section I.

---

## 2-34. REDUNDANT POWER OPERATION.

---

**WARNING**

Redundant power kit is NOT to be used for side lift operations. Use of redundant power during side lift operations may result in unsafe operating conditions, resulting in damage to equipment or injury to personnel.

**CAUTION**

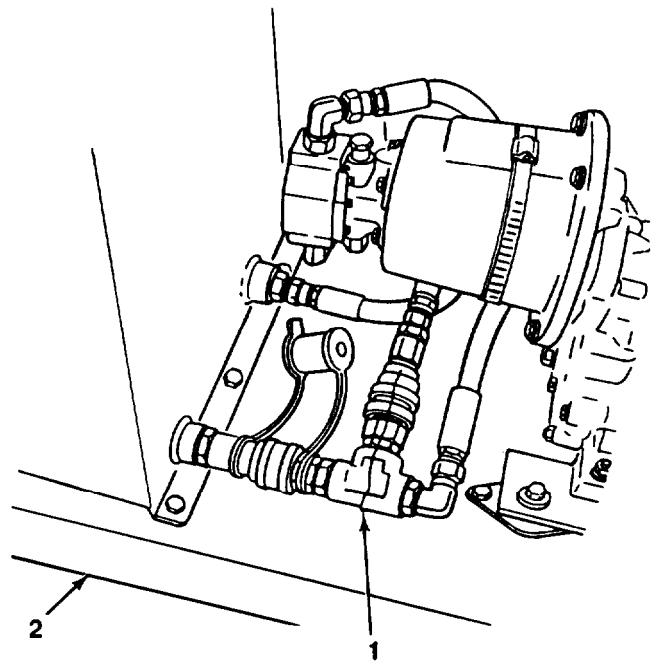
Unless in redundant power configuration, engine and hydraulic pump must not be operated with any disconnected redundant power quick disconnects on pivoting tray. Failure to follow this caution will damage hydraulic pump.

NOTE

- If either front or rear doily has engine or hydraulic pump failure, the powered (functioning) doily half can operate the nonpowered (nonfunctioning) doily half.
- To perform this procedure, redundant power kit must be used. Hoses of kit are connected between redundant power quick disconnects on pivoting trays and control valve of nonpowered (nonfunctioning) doily half.
- Disconnection or connection of redundant power quick disconnects must always be done with the engine and hydraulic pump shut down.

a. Remove two redundant power kit hoses from stowage. Remove protective covers from quick disconnects.

b. At both doily halves, remove lockwire (1) from redundant power quick disconnects at pivoting tray (2). Discard lockwires.



---

**2-34. REDUNDANT POWER OPERATION (Con't).**


---

c. On powered (functioning) dolly half, disconnect quick disconnect coupler (3) from quick disconnect nipple (6).

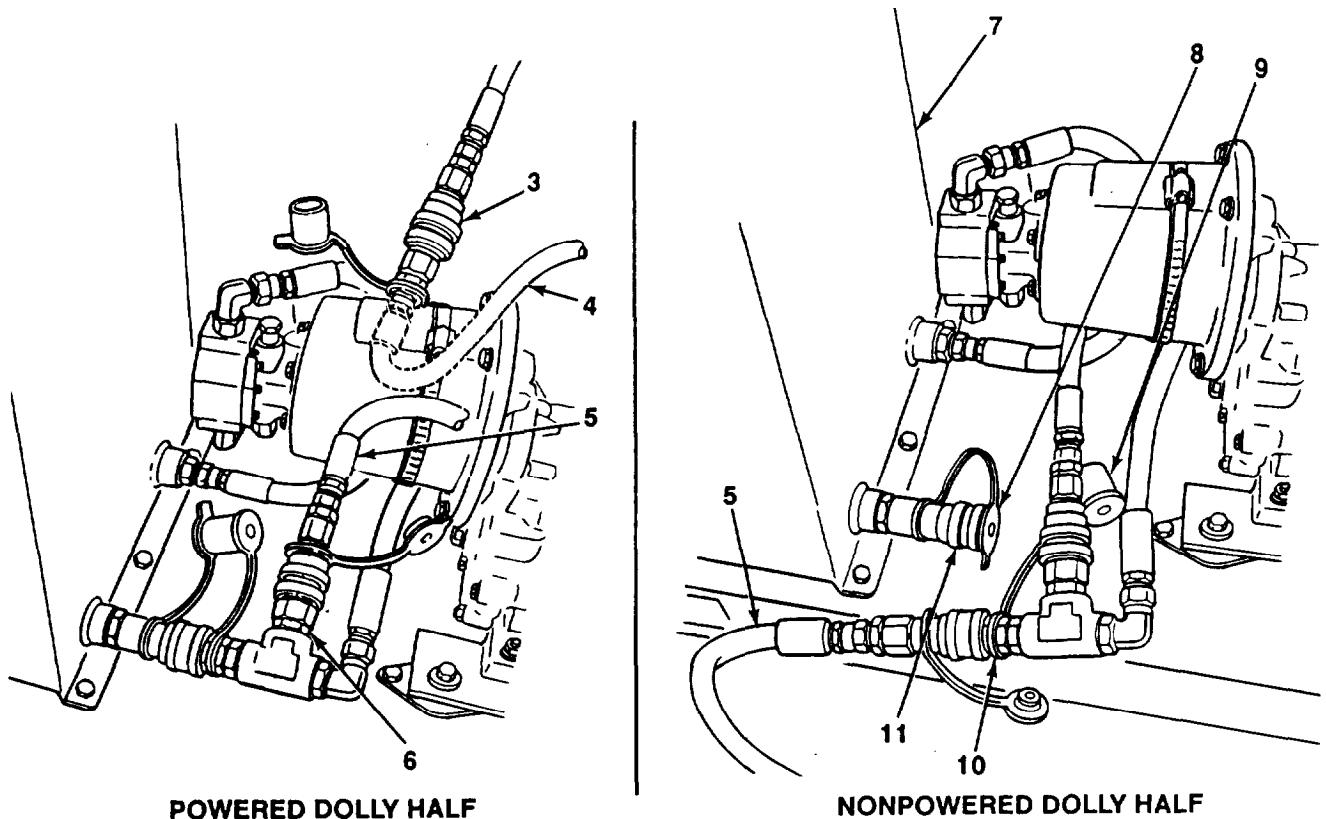
## NOTE

if quick disconnects on redundant power kit hoses cannot be connected, notify Unit Maintenance.

d. On powered dolly half, connect redundant power kit hose (5) (both ends have quick disconnect couplers) to quick disconnect nipple (6). Connect redundant power kit hose (4) (both ends have quick disconnect nipples) to quick disconnect coupler (3).

e. On nonpowered (nonfunctioning) dolly half, remove dust cap (8) from dust plug (9). Disconnect quick disconnect nipple (10) from quick disconnect coupler (11) at hydraulic reservoir (7).

f. On nonpowered dolly half, install dust cap (8) in quick disconnect coupler (11). Connect redundant power kit hose (5) (both ends have quick disconnect couplers) to quick disconnect nipple (10).



**2-34. REDUNDANT POWER OPERATION (Con't).**

g. On nonpowered dolly half, remove dust cap (14) from redundant power quick disconnect coupler (13) at control valve (12). Connect redundant power operation hose (4) (both ends have quick disconnect nipples) to redundant power quick disconnect coupler.

**NOTE**

With redundant power operation, dolly halves cannot be operated simultaneously as with normal operation.

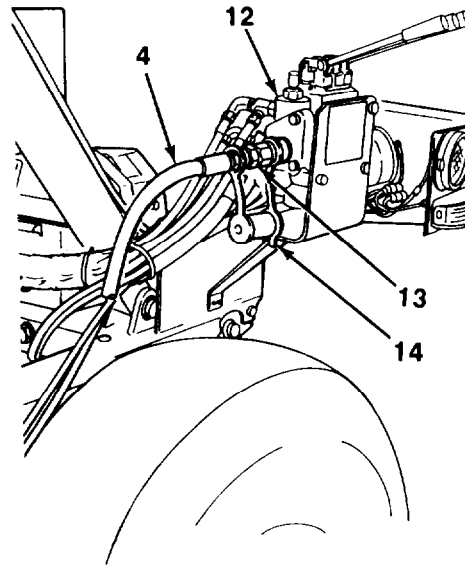
h. Start engine on powered dolly half (see paragraph 2-20). Perform required operations, one dolly half at a time.

i. Shut down engine on powered dolly half (see paragraph 2-20).

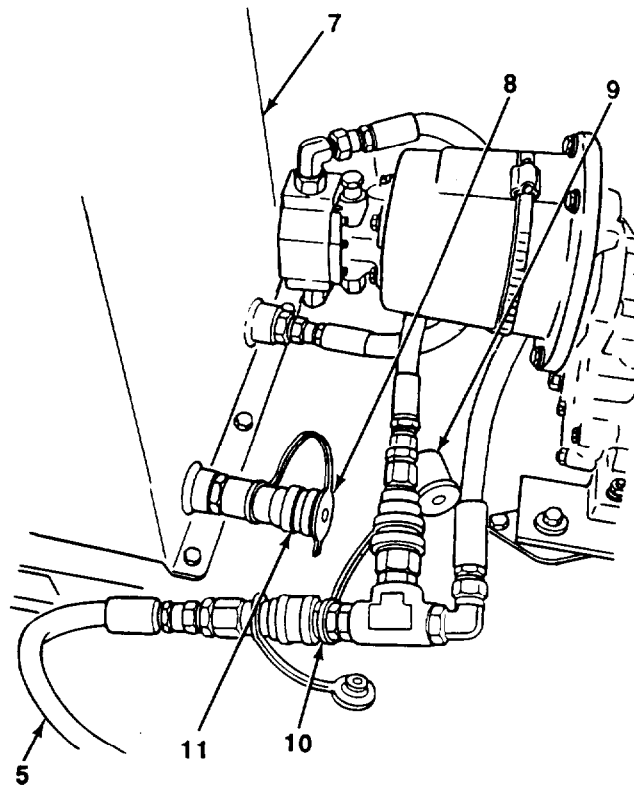
Disconnect two redundant power kit hoses (4 and 5). Install protective covers on quick disconnects and stow hoses.

k. On nonpowered dolly half, install dust cap (14) on redundant power quick disconnect coupler (13) at control valve (12).

i. On nonpowered dolly half, remove dust cap (8) from quick disconnect coupler (11) at hydraulic reservoir (7). Connect quick disconnect nipple (10) to quick disconnect coupler. install dust cap in dust plug (9).



**NONPOWERED DOLLY HALF**



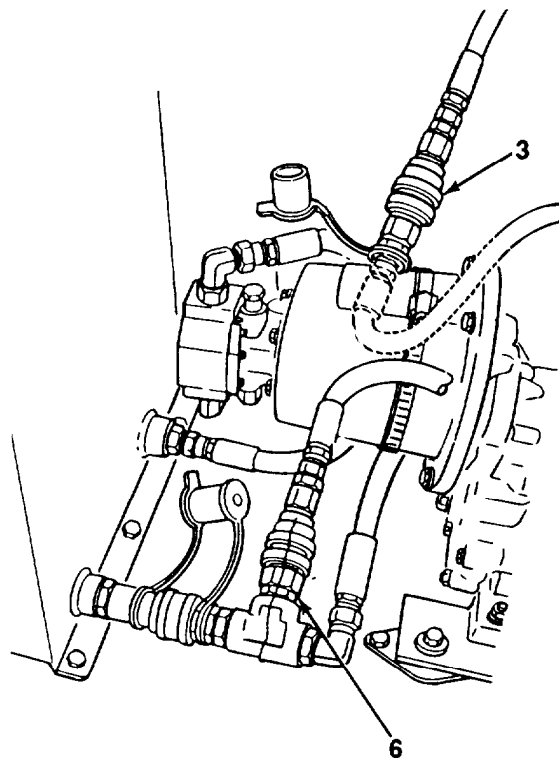
**NONPOWERED DOLLY HALF**

---

**2-34. REDUNDANT POWER OPERATION (Con't).**

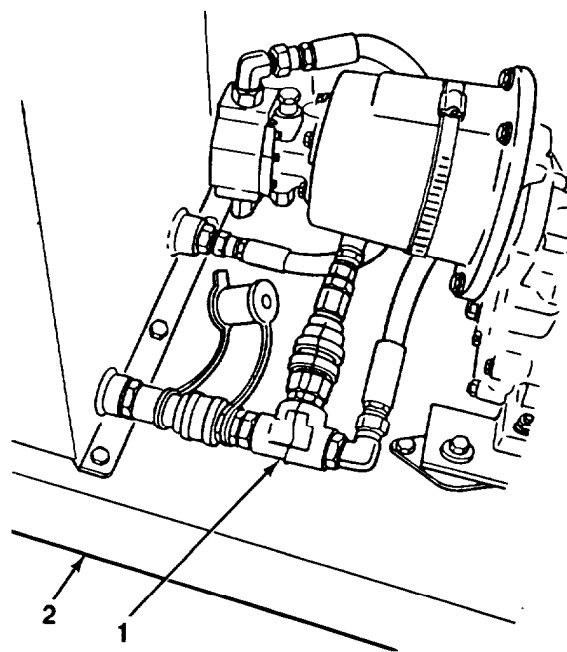
---

o. On powered dolly half, connect quick disconnect coupler (3) to quick disconnect nipple (6).



**POWERED DOLLY HALF**

p. On both dollies, notify Unit Maintenance to Install new lockwire (1) to redundant power quick disconnects at pivoting tray (2).







**CHAPTER 3  
OPERATOR/CREW MAINTENANCE**

**Section I. LUBRICATION INSTRUCTIONS**

Paragraph Number	Paragraph Title	Page Number
3-1	General .....	3-1
3-2	Specific Lubrication Instructions.....	3-1
	Lubrication Chart .....	3-2

**3-1. GENERAL.**

NOTE

These instructions are MANDATORY

- a. The M1022A1 Dolly Set must receive lubrication with approved lubricants at recommended intervals in order to be mission-ready at all times.
- b. The Lubrication Chart shows lubrication points, items to be lubricated, the required lubricants, and recommended intervals for lubrication. Any special lubricating instructions required for specific components are contained in the NOTES section of the chart.
- c. The KEY provides Information needed to select the proper lubricant for various temperature ranges and uses, and identifies the intervals.
- d. Recommended intervals are based on normal conditions of operation, temperature, and humidity. When operating under extreme conditions, lubricants should always be changed more frequently. When in doubt, notify your supervisor.

**3-2. SPECIFIC LUBRICATION INSTRUCTIONS.**

- a. Keep all lubricants In a closed container and store in a clean, dry place away from extreme heat. Keep container covers clean and do not allow dust, dirt, or other foreign material to mix with lubricants. Keep lubrication equipment clean and ready for use.
- b. Maintain a record of lubrication performed and report any problems noted during lubrication. Refer to DA Pam 738-750 for maintenance forms and procedures to record and report any findings.
- c. Keep all external parts of equipment not requiring lubrication free of lubricants. After lubrication, wipe off excess oil or grease to prevent accumulation of foreign matter.
- d. Refer to FM 9-207 for lubrication instructions in cold weather.
- e. After operation in mud, sandy, or dusty conditions, clean and inspect all points of lubrication for contaminated lubricants. Change lubricants as required.

## LUBRICATION CHART

---

### DOLLY SET: LIFT, TRANSPORTABLE SHELTER, 7-1/2 TON, M1022A1 (NSN 2330-01-378-9997) (EIC: CML)

---

This Lubrication Chart Is for Crew/Operator (C) or Unit (O) Maintenance. Lubrication Intervals (on-condition or hard time) are based on normal operation. Lubricate more during constant use and less during Inactive periods. Use correct grade of lubricant for seasonal temperature expected.

For equipment under manufacturer's warranty, hard time oil service intervals shall be followed. intervals shall be shortened if lubricants are known to be contaminated or If operation Is under adverse conditions (e.g., longer than usual operating hours, extended Idling periods, extreme dust, etc.).

Oil filters shall be serviced/cleaned/changed, as applicable, when:

- a. They are known to be contaminated or clogged; or
- b. At prescribed hard time intervals.

This dolly set is not enrolled In the Army Oil Analysis Program (AOAP). HARD TIME INTERVALS APPLY.

On illustrations, a dashed line (- -) means lubrication points on both sides.



Dry cleaning solvent, P-D-680, is toxic and flammable. Always wear protective

goggles and gloves, and use only in a well-ventilated area. Avoid contact with skin, eyes, and clothes, and DO NOT breathe vapors. DO NOT use near open flame or excessive heat. The solvent's flash point is 100°F-138°F (38°C-59°C). if you become dizzy while using cleaning solvent, immediately get fresh air and medical help. if solvent contacts eyes, immediately wash your eyes and seek medical attention.

Clean all fittings and area around lubrication points with dry cleaning solvent (Item 27, Appendix F) or equivalent before lubricating equipment. After lubrication, wipe off excess oil or grease to prevent accumulation of foreign matter.

Before you start your lubrication service:

#### ALWAYS

- a. Clean grease fittings before lubricating.
- b. Use the Lubrication Chart as your guide.

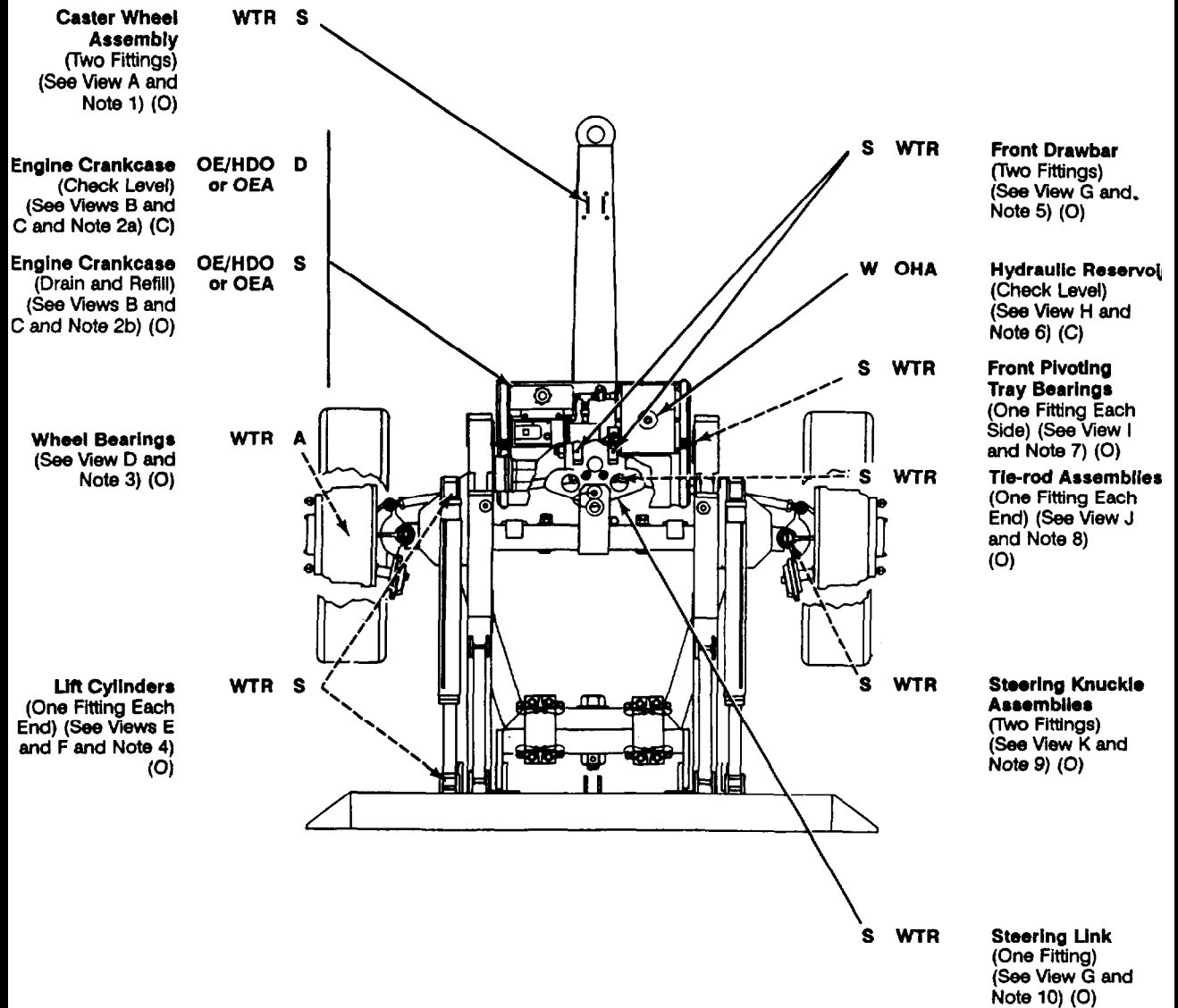
#### NEVER

- a. Use wrong type/grade grease.
- b. Use too much lubricant.

**FRONT DOLLY**

**LUBRICANT • INTERVAL**

**INTERVAL • LUBRICANT**



**TOTAL MAN-HOURS\***

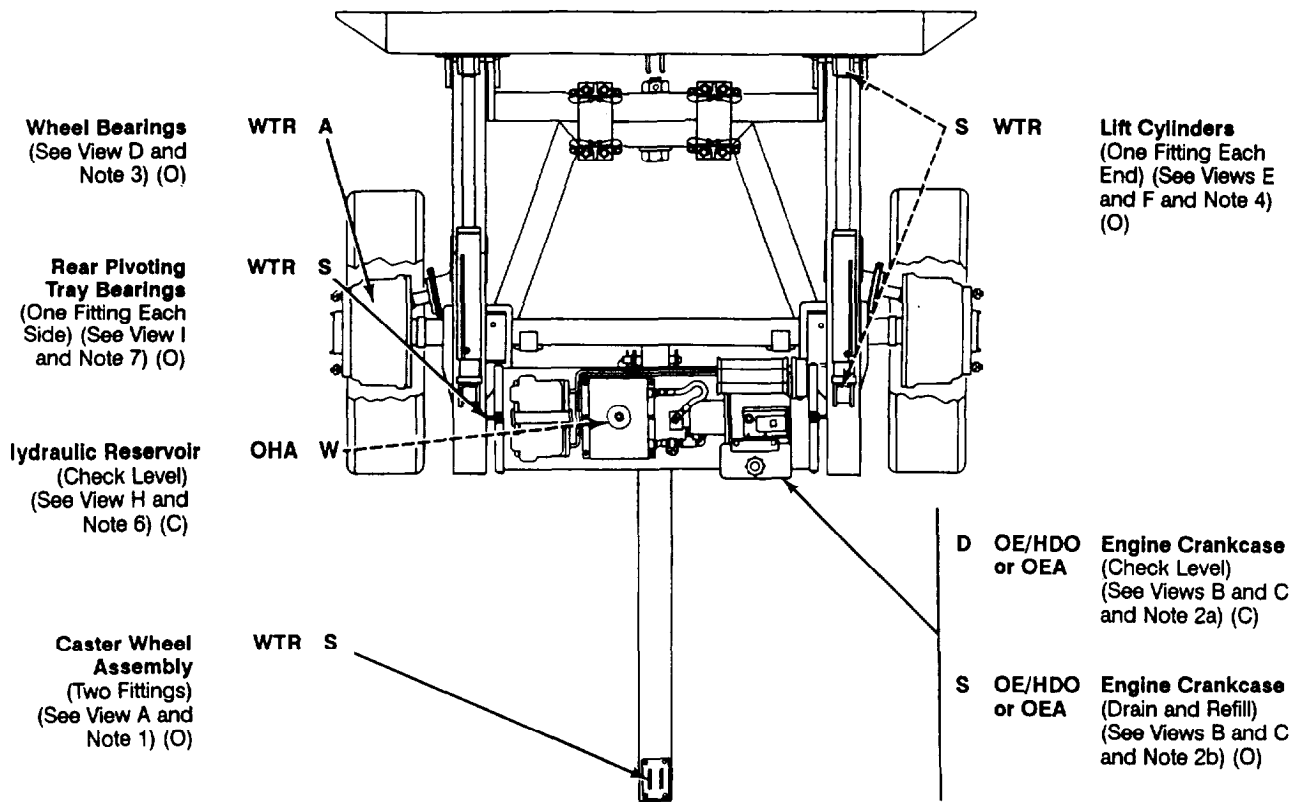
INTERVAL	MAN-HOUR	INTERVAL	MAN-HOUR
D	0.4	S	1.5
W	0.2	A	2.0

\* The man-hour time specified is the time you need to do all services prescribed for a particular interval.

**REAR DOLLY**

**LUBRICANT • INTERVAL**

**INTERVAL • LUBRICANT**



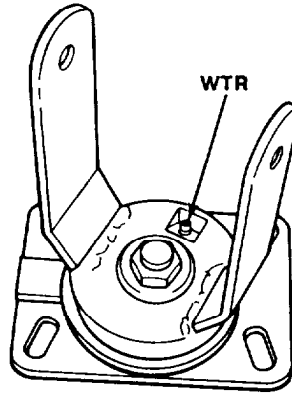
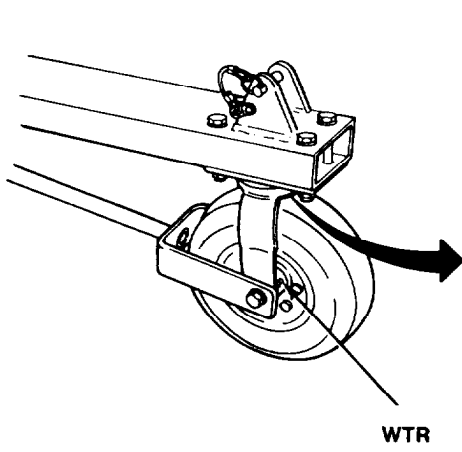
**TOTAL MAN-HOURS\***

INTERVAL	MAN-HOUR	INTERVAL	MAN-HOUR
D	0.4	S	1.0
W	0.2	A	2.0

\* The man-hour time specified is the time you need to do all services prescribed for a particular interval.

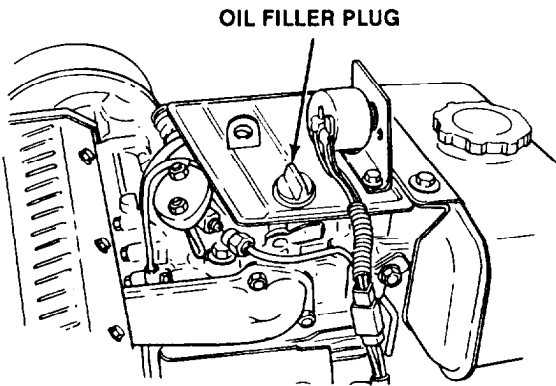
- KEY -					
Lubricant/ Component	Refill Capacity	Expected Temperatures*			intervals
		Above +32°F (Above 0°C)	+40°F to -10°F (+4°C to -23°C)	0°F to -65°F (-16°C to -54°C)	
OE/HDO (MIL-L-2104) Lubricating Oil, ICE, Tactical  OEA (MIL-L-46167) Lubricating Oil, ICE, Arctic • Engine Crankcase  • Oil Can Points	1.37 qt (1.30 I)	OE/HDO-30	OE/HDO-10	OEA	D - Daily W- Weekly S - Semiannually A - Annually
OHA (MIL-H-5606) Hydraulic Fluid, Petroleum Base • Hydraulic Reservoir: - Standard Lift Operation - Side Lift Operation	4.90 gl (18.60 I)  8.90 gl (33.70 I)	All Temperatures			
WTR (MIL-G-81322) Grease, Aircraft		All Temperatures			
* For Arctic operation, refer to FM 9-207.					

**(A) CASTER WHEEL ASSEMBLY**

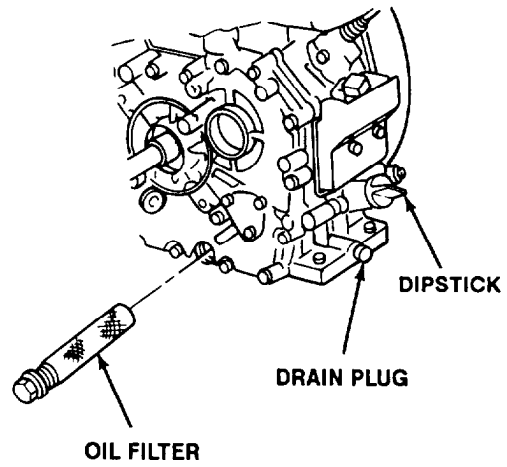


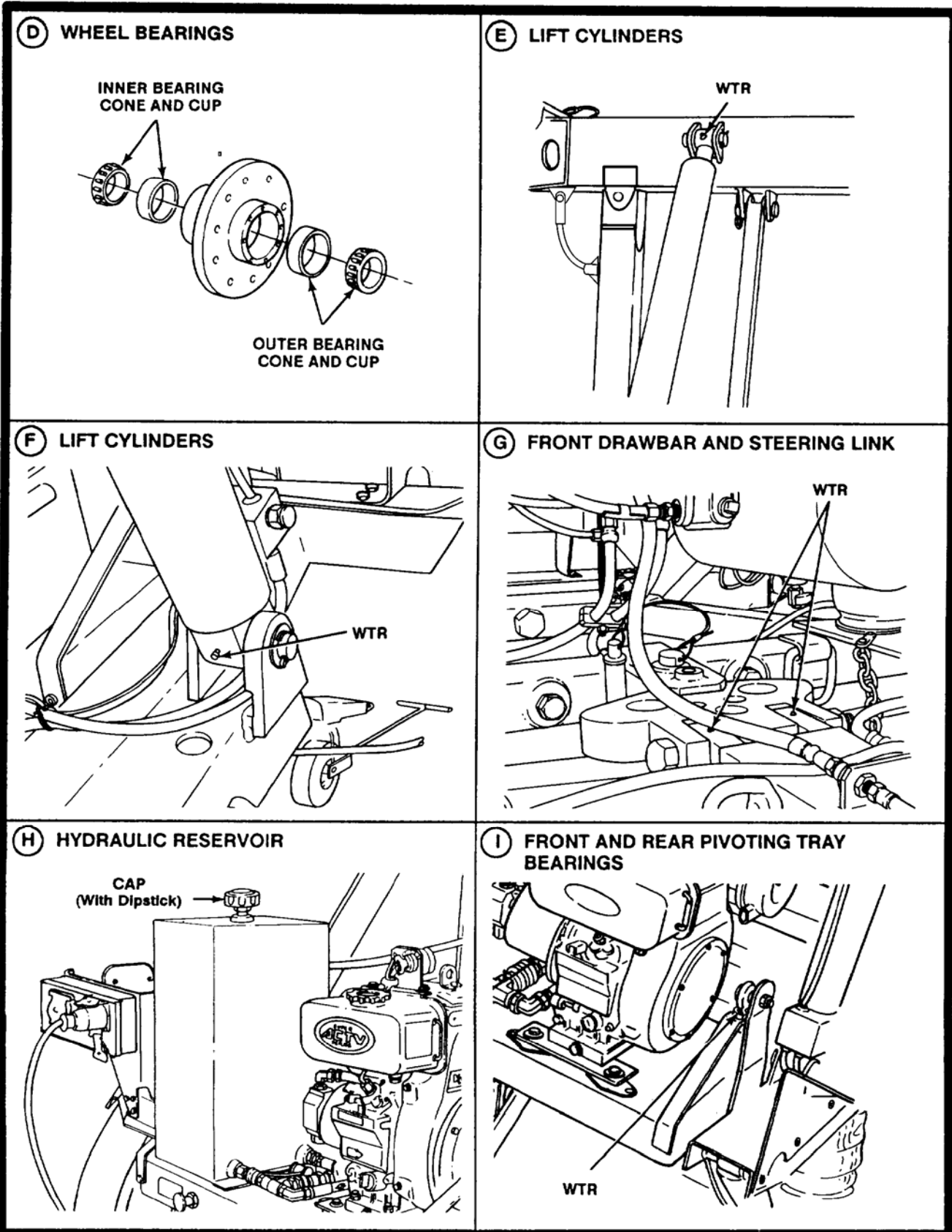
**UNDERSIDE OF  
CASTER WHEEL FORK**

**(B) ENGINE CRANKCASE**



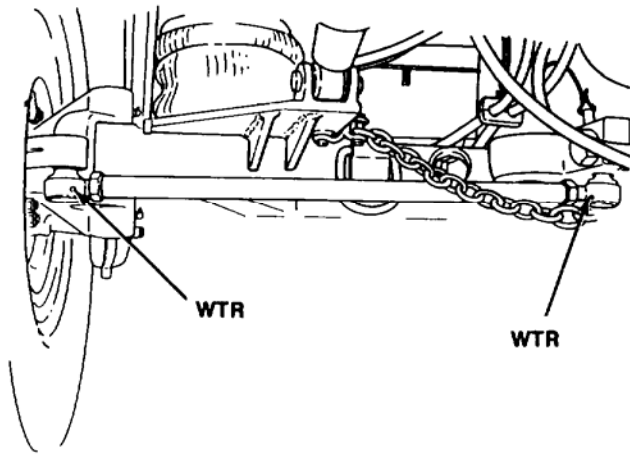
**(C) ENGINE CRANKCASE**



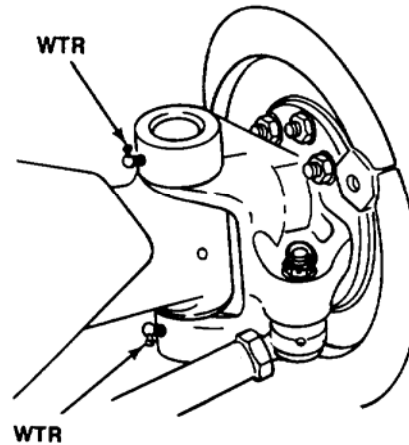


DS1022-091

**J TIE-ROD ASSEMBLIES**



**K STEERING KNUCKLE ASSEMBLIES**



**NOTES:**

**1. CASTER WHEEL ASSEMBLY.** Semiannually, lubricate fittings on wheel and on fork with WTR. To gain access, deflate tire or remove wheel.

**2. ENGINE CRANKCASE.**

- a. Daily, remove dipstick from crankcase and check level of oil. Level must show on dipstick. Oil level is FULL If oil coats threads of dipstick. Add oil as required (see paragraph 3-8).

**NOTE**

**If engine is new, the following service MUST be performed after initial week of operation.**

- b. Semiannually, remove drain plug and drain all oil from crankcase. Remove oil filter and clean. Install filter and drain plug, and fill crankcase through filler opening until oil level shows on dipstick (see paragraph 4-118).

**NOTE:**

**If dolly set was required to ford water that covered the wheel hubs, have Unit Maintenance check, clean, and lubricate wheel bearings.**

**3. WHEEL BEARINGS.** Annually, remove wheel bearings, clean, inspect, pack with WTR, install, and adjust (see paragraph 4-75 and TM 9-214).

**4. LIFT CYLINDERS.** Semiannually, lubricate fitting on each end of lift cylinders with WTR.

**5. FRONT DRAWBAR.** Semiannually, lubricate two fittings with WTR.

**6. HYDRAULIC RESERVOIR.** Weekly, before operation, lower dolly set to ground and retract all hydraulic cylinders. Remove cap and check level of hydraulic fluid on dipstick. Add hydraulic fluid (Item 15, Appendix F) as required (see paragraph 3-7).

**7. FRONT AND REAR PIVOTING TRAY BEARINGS.** Semiannually, lubricate fitting at each bearing with WTR.

**8. TIE-ROD ASSEMBLIES.** Semiannually, lubricate fitting on each end of tie-rod assemblies with WTR.

**9. STEERING KNUCKLE ASSEMBLIES.** Semiannually, lubricate two fittings with WTR.

**10. STEERING LINK.** Semiannually, lubricate fitting with WTR.

**11. OIL CAN POINTS.** Semiannually, lubricate stowage, top hook, pivoting tray lockout brace, and telescopic brace pins with PL-S (Item 24, Appendix.



**Section II. OPERATOR/CREW TROUBLESHOOTING PROCEDURES**

Paragraph Number	Paragraph Title	Page Number
3-3.	General .....	3-9
3-4.	Explanation of Columns .....	3-9
3-5.	Troubleshooting Symptom Index .....	3-10
Table 3-1.	Operator/Crew Troubleshooting .....	3-11

**3-3. GENERAL.**

- a. This section provides information for identifying and correcting malfunctions which may develop while operating the M1022A1 Dolly Set.
- b. The Troubleshooting Symptom Index (see paragraph 3-5) lists common malfunctions which may occur and refers you to the proper page in Table 3-1 for a troubleshooting procedure.
- c. If you are unsure of the location of an Item mentioned In troubleshooting, refer to paragraphs 1-11 and 2-2.
- d. Before performing troubleshooting, read and follow all safety instructions found In the warning summary at the front of this manual.
- e. This section cannot list all malfunctions that may occur, nor all tests or inspections and corrective actions. If a malfunction is not listed, or is not corrected by the listed corrective actions, notify your supervisor.
- f. When troubleshooting a malfunction:
  - (1) Locate the symptom or symptoms in paragraph 3-5 that best describes the malfunction. If the appropriate symptom is not listed, notify your supervisor.
  - (2) Turn to the page in Table 3-1 where the troubleshooting procedures for the malfunction in question are described. Headings at the top of each page show how each troubleshooting procedure is organized: Malfunction, Test of Inspection (In step number order), and Corrective Action.
  - (3) Perform each step in the order listed until the malfunction is corrected and the item being inspected is operational. DO NOT perform any maintenance task unless the troubleshooting procedure tells you to do so.

**3-4. EXPLANATION OF COLUMNS.**

The columns in Table 3-1 are defined as follows:

- (1) MALFUNCTION. A visual or operational indication that something is wrong with the dolly set.
- (2) TEST OR INSPECTION. A procedure to isolate the problem in a system or component.
- (3) CORRECTIVE ACTION. A procedure to correct the problem.

---

**3-5. TROUBLESHOOTING SYMPTOM INDEX.**

---

	Troubleshooting Procedure Page
<b>BRAKE SYSTEM</b>	
Brakes Do Not Release .....	3-14
Grab .....	3-14
No Brakes .....	3-13
Parking Brakes (Rear Dolly) Do Not Hold. ....	3-13
Weak Brakes .....	3-13
<b>ELECTRICAL SYSTEM</b>	
Dim Lamps .....	3-12
Flickering Lamps .....	3-12
Lamps:	
Dim .....	3-12
Fail to Light:	
All (Front and Rear Dollies) .....	3-11
One or More (But Not All) .....	3-12
Rear Dolly .....	3-12
Flickering... .....	3-12
<b>ENGINE</b>	
Exhaust Observed (Excessive):	
Black .....	3-19
Blue .....	3-19
Gray,Dark .....	3-19
White .....	3-19
Full Power Not Developed. ....	3-18
Misfires .....	3-18
Runs Rough .....	3-18
Starts But Will Not Run .....	3-18
Turns Over But Will Not Start .....	3-16
Will Not:	
Starting Cold Weather .....	3-17
Turn Over (With Starter Switch Set to ST) .....	3-16
<b>HYDRAULIC SYSTEM</b>	
Will Not Operate .....	3-15

---

**3-5. TROUBLESHOOTING SYMPTOM INDEX (Con't).**

---

	Troubleshooting Procedure Page
<b>TIRES</b>	
Scuffed .....	3-14
Wear:	
Abnormal .....	3-14
Uneven .....	3-14
 <b>TRACKING</b>	
Pulls to One Side .....	3-15

Table 3-1. Operator/Crew Troubleshooting.

---

**MALFUNCTION**

**TEST OR INSPECTION**

**CORRECTIVE ACTION**

---

ELECTRICAL SYSTEM

1. ALL LAMPS (FRONT AND REAR DOLLIES) FAIL TO LIGHT.

Step 1. Check that towing vehicle lights are turned on.

Turn on towing vehicle lights (see towing vehicle Operator's Manual).

Step 2. Check intervehicular cable for proper connection.

Properly connect Intervehicular cable (see paragraph 2-11).

Step 3. Check intervehicular cable for damage.

Clean dirty connector plugs or pins with a clean rag (Item 25, Appendix F).

If intervehicular cable is broken or connector plug pins are corroded or otherwise damaged, notify Unit Maintenance.

Table 3-1. Operator/Crew Troubleshooting (Con't).

MALFUNCTION	TEST OR INSPECTION	CORRECTIVE ACTION
-------------	--------------------	-------------------

2. REAR DOLLY LAMPS FAIL TO LIGHT.

- Step 1. Check intradolly cable for proper connection.
  - Properly connect intradolly cable (see paragraph 2-11).
- Step 2. Check intradolly cable for damage.
  - Clean dirty connector plugs or pins with a clean rag (Item 25, Appendix F).
  - If intradolly cable is broken or connector plug pins are corroded or otherwise damaged, notify Unit Maintenance.

3. ONE OR MORE LAMPS (BUT NOT ALL) FAIL TO LIGHT.

- Step 1. Check affected light(s) for dirty, loose, or disconnected connector plug(s).
  - Clean dirty connector plug(s) with a clean rag (Item 25, Appendix F).
  - Securely connect connector plug(s) at affected light(s).
- Step 2. Check Intervehicular and intradolly cables for damage.
  - Clean ditty connector plugs or pins with a clean rag (Item 25, Appendix F).
  - If cables are broken or connector plug pins are corroded or otherwise damaged, notify Unit Maintenance.

4. DIM OR FLICKERING LAMPS.

- Step 1. Check intervehicular and intradolly cables for secure connection.
  - Securely connect intervehicular and intradolly cables (see paragraph 2-11).
- Step 2. Check Intervehicular and Intradolly cables for damage.
  - Clean dirty connector plugs or pins with a clean rag (Item 25, Appendix F).
  - If cables are broken or connector plug pins are corroded or otherwise damaged, notify Unit Maintenance.
- Step 3. Check towing vehicle battery for adequate charge (see towing vehicle Operator's Manual).
  - If towing vehicle battery requires charging, notify Unit Maintenance.

Table 3-1. Operator/Crew Troubleshooting (Con't).

MALFUNCTION	TEST OR INSPECTION	CORRECTIVE ACTION
BRAKE SYSTEM		
5. NO BRAKES OR WEAK BRAKES.		
Step 1.	Check air gage in towing vehicle to ensure that adequate air pressure has been built. Air gage should read at least 80 psi (552 kPa).	If air gage reading is low, notify Unit Maintenance.
Step 2.	Check air valves at rear of towing vehicle to ensure that they are open.	Open air valves (see towing vehicle Operator's Manual).
Step 3.	If tandem towing, check that shutoff valves at rear of towing dolly set are open.	Open shutoff valves (see paragraph 2-19).
Step 4.	If only one dolly set is being towed, check that shutoff valves at rear of dolly set are closed.	Close shutoff valves (see paragraph 2-19).
Step 5.	Check intervehicular and intradolly service and emergency air hoses for proper connection.	Properly connect intervehicular and intradolly service and emergency air hoses (see paragraph 2-11).
Step 6.	Check for open air reservoir draincocks.	Close air reservoir draincocks (see paragraph 3-6).
step 7.	Check intervehicular, intradolly, and all other air hoses for kinks, cuts, breaks, or loose connections. Be alert for sound of leaking air.	Remove kinked intervehicular or Intradolly air hoses, remove kinks, and connect. If air hoses are damaged, notify Unit Maintenance.
6. PARKING BRAKES (REAR DOLLY) DO NOT HOLD.		
Step 1.	Check parking brake lever for correct position.	Set parking brake lever to ON position.
Step 2.	Check if brakes on rear dolly are caged.	If brakes on rear dolly are caged, notify Unit Maintenance.

Table 3-1. Operator/Crew Troubleshooting (Con't).

MALFUNCTION	TEST OR INSPECTION	CORRECTIVE ACTION
-------------	--------------------	-------------------

7. BRAKES DO NOT RELEASE.

- Step 1. Check air gage in towing vehicle to ensure that adequate air pressure has been built. Air gage should read at least 80 psi (552 kPa).  
If air gage reading is low, notify Unit Maintenance.
- Step 2. Check air valves at rear of towing vehicle to ensure that they are open.  
Open air valves (see towing vehicle Operator's Manual).
- Step 3. Check for open air reservoir draincocks.  
Close air reservoir draincocks (see paragraph 3-6).
- Step 4. Check parking brake lever for correct position.  
Set parking brake lever to OFF position.
- Step 5. If tandem towing, check that shutoff valves at rear of towing dolly set are open.  
Open shutoff valves (see paragraph 2-19).
- Step 6. Check intervehicular and intradolly service and emergency air hoses for proper connection.  
Properly connect intervehicular and intradolly service and emergency air hoses (see paragraph 2-11).
- Step 7. Check inter-vehicular, intradolly, and all other air lines for kinks, cuts, breaks, or loose connections. Be alert for sound of leaking air.  
Remove kinked intervehicular or intradolly air hoses, remove kinks, and connect.  
If air hoses are damaged, notify Unit Maintenance.

8. BRAKES GRAB.

- If operating in extreme cold, check for moisture in air reservoirs.  
Drain moisture from air reservoirs (see paragraph 3-6). Notify Unit Maintenance.

---

TIRES

9. TIRES SCUFFED OR UNEVEN OR ABNORMAL WEAR.

- Step 1. Check for correct tire inflation.  
Inflate tires to 110 psi (758 kPa) for highway, cross-country, or mud.

Table 3-1. Operator/Crew Troubleshooting (Con't).

MALFUNCTION	TEST OR INSPECTION	CORRECTIVE ACTION
	Step 2.	<p>Check for improper operating procedures (i.e., improper riding height, failure to release brakes at proper time).</p> <p>Ensure that shelter is towed at a level riding height. Air bags must be inflated so that upper portion of each shock absorber reaches level of ride height indicator ring (see paragraph 2-22).</p> <p>Carefully follow operating instructions for releasing brakes. If not properly released, tires will become scuffed.</p>
	Step 3.	<p>Check wheel stud nuts for looseness.</p> <p>Tighten wheel stud nuts. Notify Unit Maintenance to apply final torque.</p>

## TRACKING

## 10. DOLLY SET PULLS TO ONE SIDE.

- Step 1. Check for correct tire inflation.
- Inflate tires to 110 psi (758 kPa) for highway, cross-country, or mud.
- Step 2. Check for correct air bag inflation.
- Air bags must be inflated so that upper portion of each shock absorber reaches level of ride height indicator ring (see paragraph 2-22).

## HYDRAULIC SYSTEM

## 11. HYDRAULIC SYSTEM WILL NOT OPERATE.

- Step 1. Check level of hydraulic fluid in hydraulic reservoir (see paragraph 3-7).
- Add hydraulic fluid as required (see paragraph 3-7).
- Step 2. Check that engine speed is set to HIGH START (see paragraph 2-20).
- Set speed control lever to HIGH START (see paragraph 2-20).
- Step 3. If malfunction occurs when attempting to lower dolly set, with or without shelter, ensure that transportation lockouts have been disengaged.
- Disengage transportation lockouts (see paragraph 2-8).

Table 3-1. Operator/Crew Troubleshooting (Con't).

MALFUNCTION	TEST OR INSPECTION	CORRECTIVE ACTION
-------------	--------------------	-------------------

ENGINE

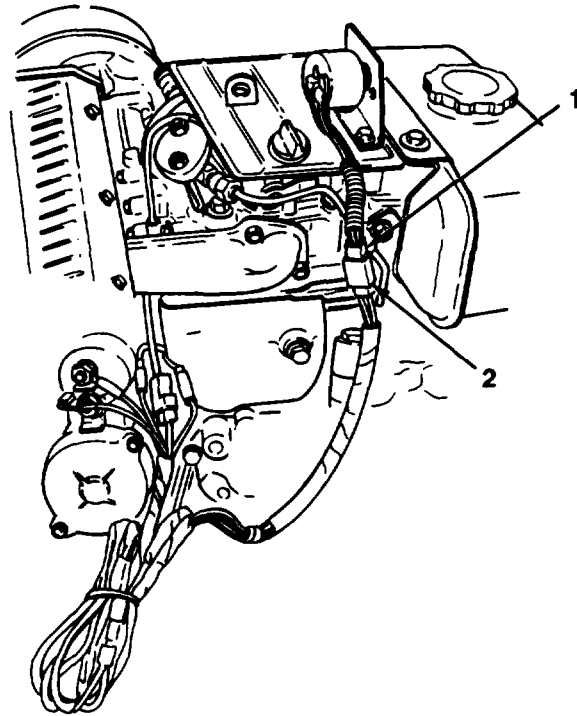
12. ENGINE WILL NOT TURN OVER WHEN STARTER SWITCH IS SET TO "ST."

Step 1. Check for a disconnected starter switch connector (1).

Connect starter switch connector (1) to engine wiring harness connector (2).

Step 2. Check battery for disconnected cables or loose or corroded battery terminals.

Notify Unit Maintenance.



13. ENGINE TURNS OVER BUT WILL NOT START.

Step 1. Check for proper starting procedures (see paragraph 2-20).

Follow proper starting procedures (see paragraph 2-20).

Step 2. Check level of fuel in fuel tank (see paragraph 3-9).

Add fuel as required (see paragraph 3-9).



Table 3-1. Operator/Crew Troubleshooting (Con't).

MALFUNCTION	TEST OR INSPECTION	CORRECTIVE ACTION
-------------	--------------------	-------------------



**WARNING**

If NBC exposure is Suspected, all engine air cleaner air filter media should be handled by personnel wearing protective equipment. Consult your NBC Officer or NBC NCO for appropriate handling or disposal procedures.

Step 3. Check air cleaner element for dirt or other obstructions.

Clean air cleaner element (see paragraph 3-10).

Step 4. Check for proper fuel (see paragraph 1-15).

Notify Unit Maintenance.

**14. ENGINE WILL NOT START IN COLD WEATHER [BELOW 41°F (5°C)].**

**NOTE**

If opening engine in temperatures below 0°F (-18°C), refer to paragraph 2-25 for proper Starting procedures.

Step 1. Check for proper starting procedures (see paragraph 2-20).

Ensure that starter switch is left at GL for five seconds and decompression lever is pushed before turning starter switch to ST (see paragraph 2-20).

Step 2. Check for a disconnected glow plug cord connector (3).

Connect glow plug cord connector (3) to engine wiring harness connector (4).

Step 3. Check for proper fuel (see paragraph 1-15).

Notify Unit Maintenance.

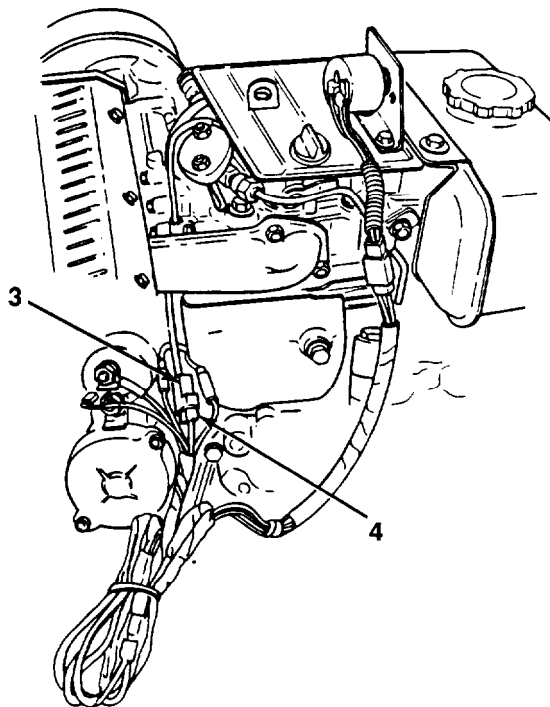


Table 3-1. Operator/Crew Troubleshooting (Con't).

---

MALFUNCTION	TEST OR INSPECTION	CORRECTIVE ACTION
-------------	--------------------	-------------------

---

15. ENGINE STARTS BUT DOES NOT CONTINUE TO RUN.

Check level of fuel in fuel tank (see paragraph 3-9).

Add fuel as required (see paragraph 3-9).

16. ENGINE RUNS ROUGH (MISFIRES).



If NBC exposure is suspected, all engine air cleaner air filter media should be handled by personnel wearing protective equipment. Consult your NBC Officer or NBC NCO for appropriate handling or disposal procedures.

Check air cleaner element for dirt or other obstructions.

Clean air cleaner element (see paragraph 3-10).

17. ENGINE DOES NOT DEVELOP FULL POWER.



If NBC exposure is Suspected, all engine air cleaner air filter media should be handled by personnel wearing protective equipment. Consult your NBC Officer or NBC NCO for appropriate handling or disposal procedures.

Check air cleaner element for dirt or other obstructions.

Clean air cleaner element (see paragraph 3-10).

Table 3-1. Operator/Crew Troubleshooting (Con't).

MALFUNCTION	TEST OR INSPECTION	CORRECTIVE ACTION
-------------	--------------------	-------------------

## 18. EXCESSIVE BLACK OR DARK GRAY EXHAUST IS OBSERVED.



If NBC exposure is suspected, all engine air cleaner air filter media should be handled by personnel wearing protective equipment. Consult your NBC Officer or NBC NCO for appropriate handling or disposal procedures.

Step 1. Check air cleaner element for dirt or other obstructions.

Clean air cleaner element (see paragraph 3-10).

Step 2. Check for proper fuel (see paragraph 1-15).

Notify Unit Maintenance.

## 19. EXCESSIVE WHITE OR BLUE EXHAUST IS OBSERVED.

Check crankcase oil level (see paragraph 3-8).

If crankcase oil level is too high, notify Unit Maintenance.

### Section III. OPERATOR/CREW MAINTENANCE

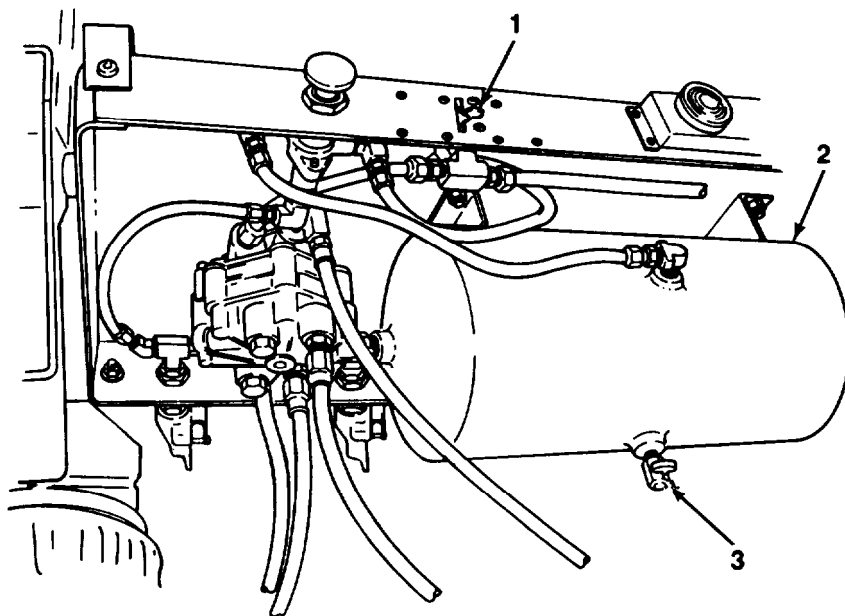
Paragraph Number	Paragraph Title	Page Number
3-6.	Draining Air Reservoir .....	3-26
3-7.	Checking and Filling Hydraulic Fluid .....	3-21
3-8.	Checking and Filling Crankcase Oil .....	3-23
3-9.	Checking and Filling Engine Fuel .....	3-26
3-10.	Cleaning Engine Air Cleaner Element .....	3-28

#### 3-6. DRAINING AIR RESERVOIR.

NOTE

Perform this task at both front and rear dolly air reservoirs.

- a. On rear dolly, turn parking brake lever (1) to ON position to apply dolly set parking brakes.
- b. Disconnect intervehicular and intradolly air lines (see paragraph 2-7).



---

### 3-6. DRAINING AIR RESERVOIR (Con't).

---



Wear protective eye goggles when opening air reservoir draincock and avoid air stream. Failure to follow this warning may result In eye Injury.

- c. Open draincock (3) on air reservoir (2). Allow all compressed air and condensation to drain. Leave draincock open.
- d. Before operation, close draincock (3) on air reservoir (2).
- e. Connect intervehicular and intradolly air lines (see paragraph 2-11).

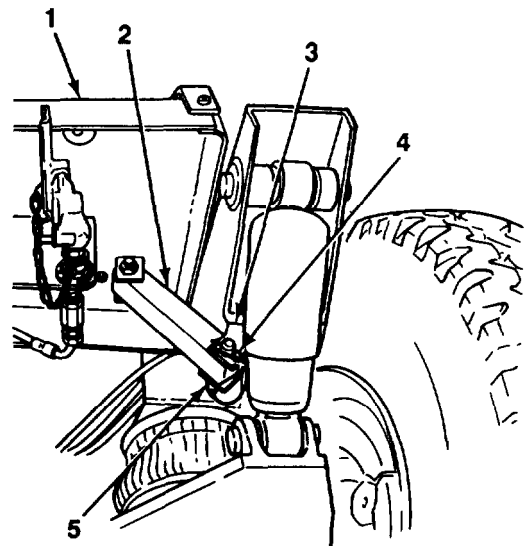
---

### 3-7. CHECKING AND FILLING HYDRAULIC FLUID.

---

#### NOTE

- Perform this task at both front and rear dolly hydraulic reservoirs.
  - Dolly set should be lowered to ground with lift and positioning cylinders fully retracted to ensure an accurate reading.
- a. Park dolly set on level ground. If pivoting tray (1) is not level, remove safety pin (4) and hitch pin (5) and unlock pivoting tray lockout brace (2) from lower bracket (3).



---

### 3-7. CHECKING AND FILLING HYDRAULIC FLUID (Con't).

---

**CAUTION**

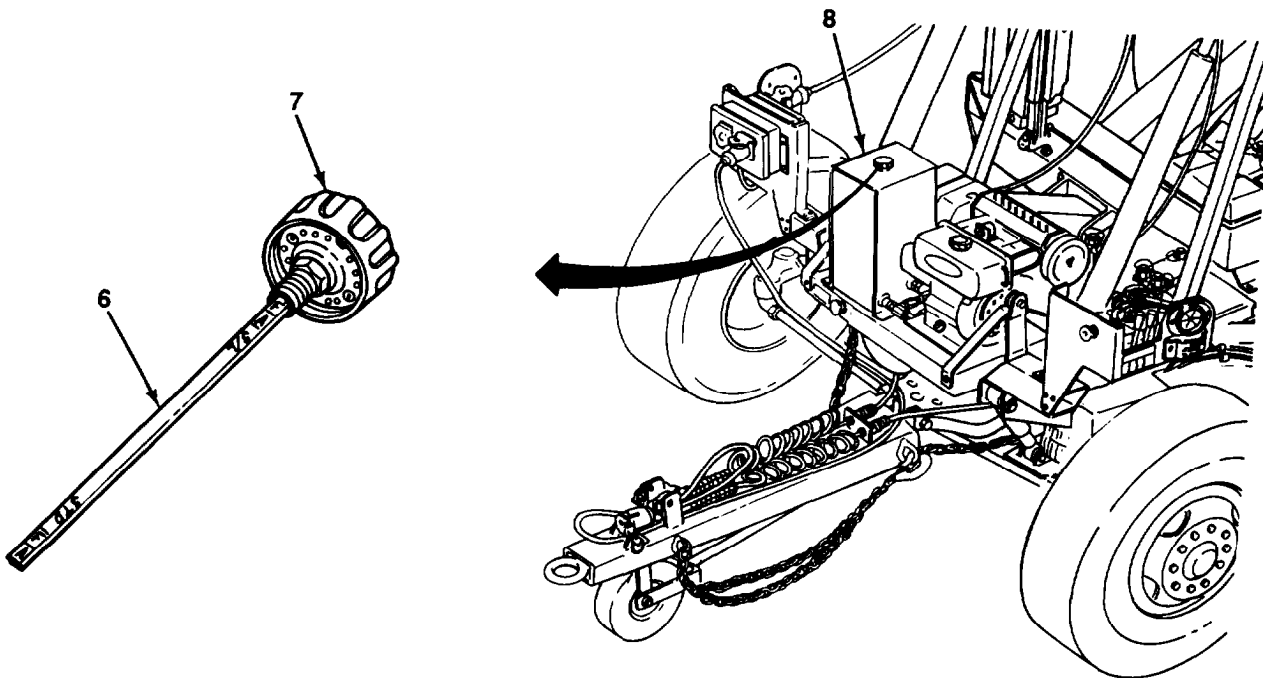
DO NOT allow dirt or dust to enter hydraulic reservoir. Damage to hydraulic system will result.

b. Remove cap (7) from hydraulic reservoir (8). Wipe dipstick (8) clean with a clean rag (Item 25, Appendix F). Install cap in reservoir.

NOTE

Hydraulic fluid level differs for M1022A1 and M1022A1 with side lift kit Installed. Proper level for M1022A1 (STD) Is marked near tip of dipstick. Proper level for M1022A1 with side lift kit (S/L) Is marked near cap end of dipstick.

c. Remove cap (7) from hydraulic reservoir (8) and check level of hydraulic fluid on dipstick (6). Level should be even with FULL (F) mark. If level Is at or below ADD (A) mark, add hydraulic fluid (Item 15, Appendix F). Install cap in reservoir.



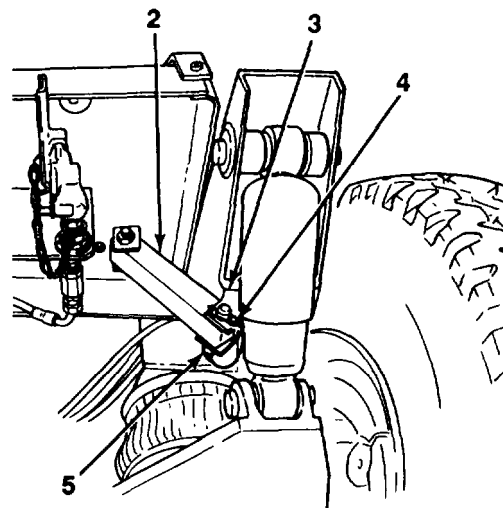
---

### 3-7. CHECKING AND FILLING HYDRAULIC FLUID (Con't).

---

d. If checking hydraulic fluid level after replacement of a hydraulic component (hydraulic cylinder, control valve, etc.), start engine (see paragraph 2-20) and operate hydraulic control valve to circulate hydraulic fluid throughout system (see paragraph 2-21). Check level of hydraulic fluid (see steps b and c).

e. Lock pivoting tray lockout brace (2) to lower bracket (3) with hitch pin (5) and safety pin (4).




---

### 3-8. CHECKING AND FILLING CRANKCASE OIL.

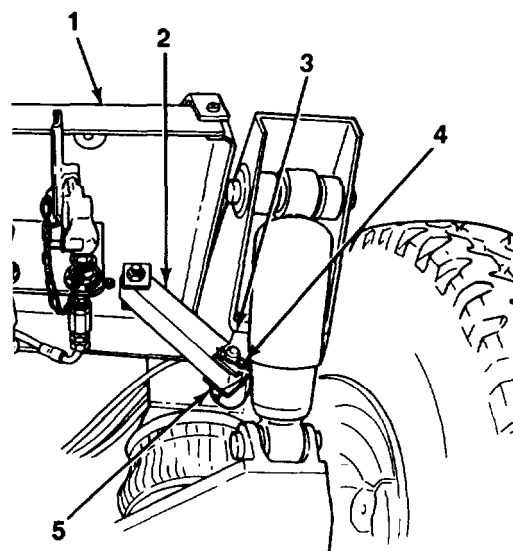
---

#### NOTE

Perform this task at both front and rear dolly engines.

#### a. Checking Crankcase Oil Level.

(1) Park dolly set on level ground. If pivoting tray (1) is not level, remove safety pin (4) and hitch pin (5) and unlock pivoting tray lockout brace (2) from lower bracket (3).



---

### 3-8. CHECKING AND FILLING CRANKCASE OIL (Con't).

---

(2) Shut down engine (see paragraph 2-20). Wait approximately two minutes for oil to drain back into crankcase (8).

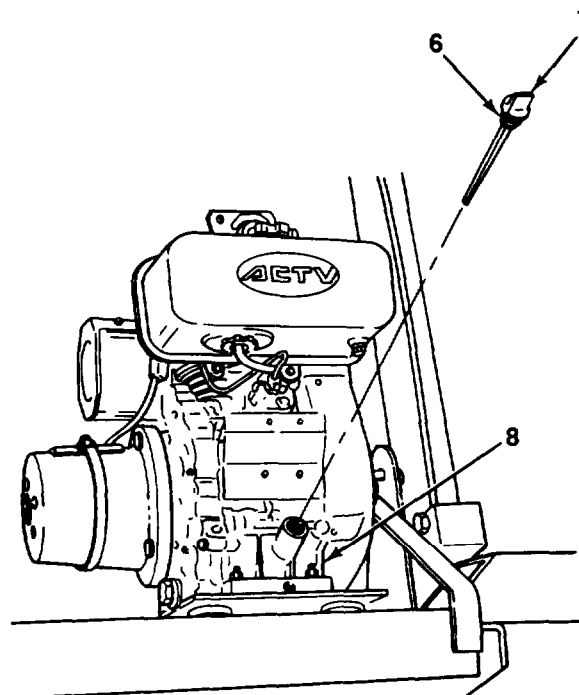
**CAUTION**

DO NOT allow dirt or dust to enter crankcase. Damage to engine will result.

(3) Remove dipstick (7) from crankcase (8). Wipe clean with a clean rag (Item 25, Appendix F). Fully install dipstick in crankcase.

(4) Remove dipstick (7) from crankcase (8). Oil level must show on dipstick. Oil level is FULL if oil coats threads (6) of dipstick.

(5) Install dipstick (7) in crankcase (8).



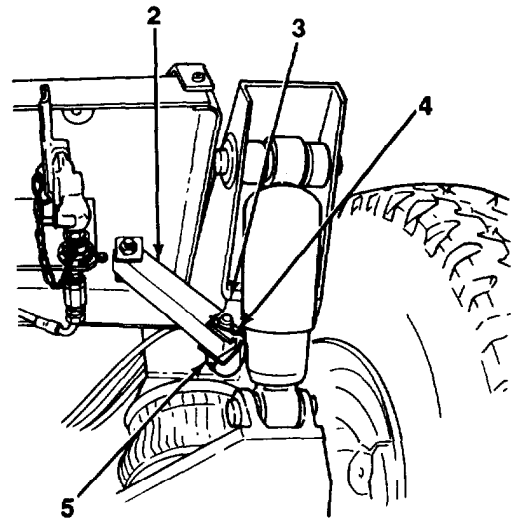


---

**3-8. CHECKING AND FILLING CRANKCASE OIL (Con't).**


---

(6) If oil level is okay, lock pivoting tray lockout brace (2) to lower bracket (3) with hitch pin (5) and safety pin (4).



**b. Filling Crankcase Oil.**

**CAUTION**

DO NOT allow dirt or dust to enter crankcase. Damage to engine will result.

(1) Remove oil filler plug (9).

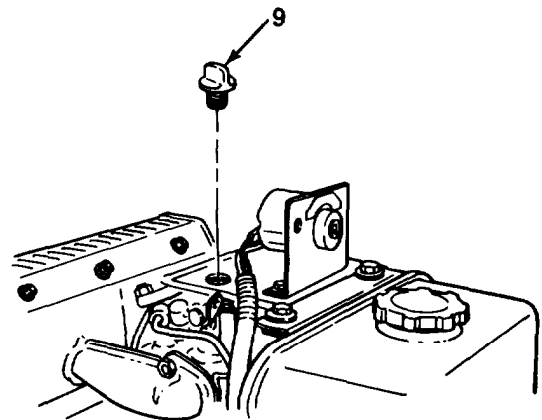
(2) Add oil (Item 21, 22, or 23, Appendix F) as required (see Lubrication Instructions, Chapter 3, Section I).

**CAUTION**

DO NOT overfill engine crankcase. Damage to engine will result.

(3) Install oil filler plug (9).

(4) Check crankcase oil level (see subparagraph a).



---

3-9. CHECKING AND FILLING ENGINE FUEL.

---



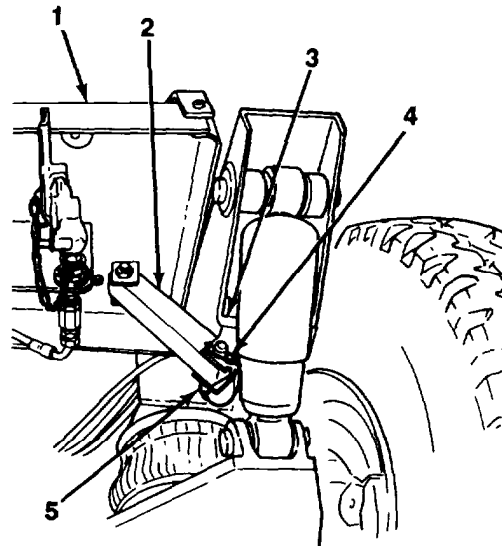
Diesel fuel is combustible. DO NOT smoke or allow an open flame near fuel tank. Shut down engine when adding fuel. Failure to follow this warning will result in serious injury or death to personnel. If you are burned, immediately seek medical attention.

NOTE

Perform this task at both front and rear dolly engines.

a. Checking Fuel Level.

(1) Park dolly set on level ground. If pivoting tray (1) is not level, remove safety pin (4) and hitch pin (5) and unlock pivoting tray lockout brace (2) from lower bracket (3).



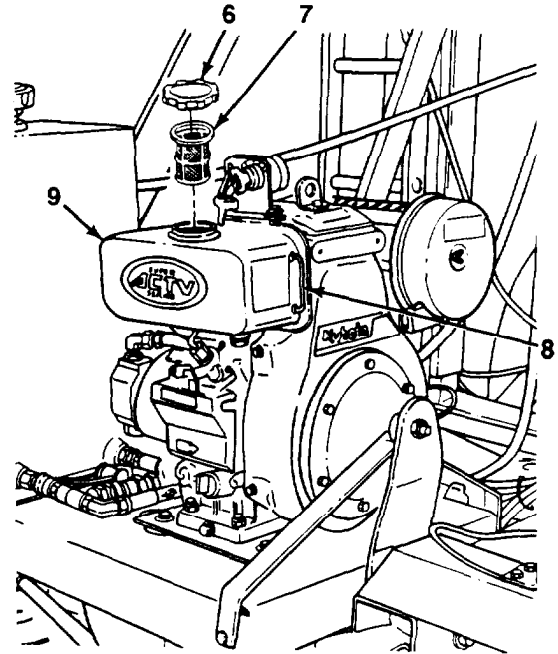
---

### 3-9. CHECKING AND FILLING ENGINE FUEL (Con't).

---

(2) Check level of fuel in fuel tank (9) using fuel indicator (8). Maximum fuel level height should be just visible at top of fuel indicator.

(3) If fuel level is okay, lock pivoting tray lockout brace (2) to lower bracket (3) with hitch pin (5) and safety pin (4).



#### b. Filling Fuel Tank.

**CAUTION**

DO NOT allow dirt or dust to enter fuel tank. Damage to engine fuel system will result.

- (1) Remove cap (6) from fuel tank (9).
- (2) Check strainer (7) for dirt or dust. Remove contaminants as required. Reinstall strainer.

#### NOTE

If fuel tank is filled too full, fuel may seep from vented cap.

- (3) Add diesel fuel (Item 17 or item 18, Appendix F) as required to fill fuel tank (9). Maximum fuel level height should be just visible at top of fuel indicator (8). DO NOT overfill.
- (4) Install cap (6) on fuel tank (9).
- (5) Lock pivoting tray lockout brace (2) to lower bracket (3) with hitch pin (5) and safety pin (4).

---

### 3-10. CLEANING ENGINE AIR CLEANER ELEMENT.

---

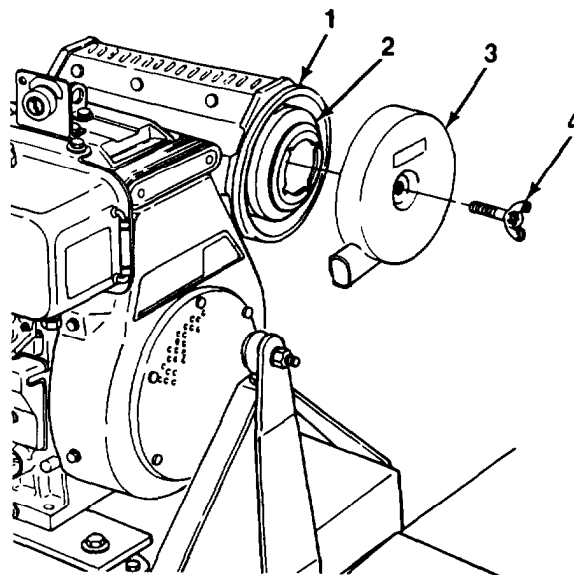


**WARNING**

If NBC exposure is suspected, all engine air cleaner air filter media should be handled by personnel wearing protective equipment. Consult your NBC Officer or NBC NCO for appropriate handling or disposal procedures.

NOTE

- Perform this task at both front and rear dolly engines.
  - If operating engine in sandy or dusty areas, air cleaner element should be cleaned dally.
  - If damage to air cleaner element is noted at any time during cleaning, notify Unit Maintenance for replacement.
- a. Remove any accumulated sand or dust from exterior of air cleaner using a clean rag (Item 25, Appendix F).
  - b. Remove wingbolt (4) and cover (3).
  - c. Remove air cleaner element (2) from body (1).
- (1).



---

**3-10. CLEANING ENGINE AIR CLEANER ELEMENT (Con't).**

---



Compressed air used for cleaning or drying purposes, or for clearing restrictions, should never exceed 30 psi (207 kPa). Wear protective clothing (goggles/shield, gloves, etc.) and use caution to avoid injury to personnel.

- d. Remove sand or dust from air cleaner element (2) by gently tapping. While rotating air cleaner element, apply compressed air from the inside.
- e. If air cleaner element (2) is oily or coated with carbon dust, soak in a solution of water and dishwashing compound (Item 7, Appendix F) for 15 minutes. Wash several times, rinse with fresh water, and allow to dry.
- f. Clean interior of body (1) as required.
- g. Install air cleaner element (2) in body (1).
- h. Install cover (3) over air cleaner element (2) with wingbolt (4). Tighten wingbolt finger-tight.



**CHAPTER 4  
UNIT MAINTENANCE**

**Section I. REPAIR PARTS; SPECIAL TOOLS; TEST, MEASUREMENT,  
AND DIAGNOSTIC EQUIPMENT (TMDE);  
AND SUPPORT EQUIPMENT**

Paragraph NUMBER	Paragraph Title	Page Number
4-1.	Common Tools and Equipment . . . . .	4-1
4-2.	Special Tools; Test, Measurement, and Diagnostic Equipment (TMDE); and Support Equipment . . . . .	4-1
4-3.	Repair Parts . . . . .	4-1

**4-1. COMMON TOOLS AND EQUIPMENT.**

For authorized common tools and equipment, refer to Appendix G, Tool Identification List, and to the Modified Table of Organization and Equipment (MTOE) applicable to your unit.

**4-2. SPECIAL TOOLS; TEST, MEASUREMENT, AND DIAGNOSTIC EQUIPMENT (TMDE); AND SUPPORT EQUIPMENT.**

Refer to Appendix B, Maintenance Allocation Chart, and Appendix C, Repair Parts and Special Tools Lists, for information on special tools and support equipment for the M1022A1 Dolly Set.

**4-3. REPAIR PARTS.**

Repair parts are listed and illustrated in Appendix C.

## Section II. SERVICE UPON RECEIPT

Paragraph Number	Paragraph Title	Page Number
4-4.	General .....	4-2
4-5.	Inspection Instructions .....	4-2
4-6.	Servicing Instructions .....	4-3

### 4-4. GENERAL.

When a new, used, or reconditioned M1022A1 Dolly Set is first received, determine whether it has been properly prepared for service and is in condition to perform its mission. Follow the inspection instructions in paragraph 4-5 and servicing instructions in paragraph 4-6.

### 4-5. INSPECTION INSTRUCTIONS.

- a. Read and follow all instructions on DD Form 1397.
- b. Remove all straps, plywood, tape, seals, wrapping, or any other shipping material.



Dry cleaning solvent, P-D-680, is toxic and flammable. Always wear protective goggles and gloves, and use only in a well-ventilated area. Avoid contact with skin, eyes, and clothes, and DO NOT breathe vapors. DO NOT use near open flame or excessive heat. The solvent's flash point is 100<sup>0</sup>F-138<sup>0</sup>F (38<sup>0</sup>C-59<sup>0</sup>C). If you become dizzy while using cleaning solvent, immediately get fresh air and medical help. If solvent contacts eyes, immediately wash your eyes and seek medical attention.

- c. If any exterior parts are coated with rust preventive compound, remove with dry cleaning solvent (Item 27, Appendix F) and rags (Item 25, Appendix F).
- d. Inspect the equipment for any damage incurred during shipment. Also check to see if the equipment has been modified.
- e. Check the equipment against the packing slip to ensure that the shipment is complete. Report any discrepancies in accordance with instructions in DA Pam 738-750.



---

**4-6. SERVICING INSTRUCTIONS.**

---

- a. Perform all Unit PMCS. Schedule the next PMCS on DD Form 314.
- b. If dolly set is new, batteries will be without electrolyte. Add electrolyte (Item 14, Appendix F) to batteries before dolly set is put into service (see TM 9-6140-200-14).
- c. Perform all lubrication, regardless of interval, as described in Lubrication Instructions (see Chapter 3, Section I).
- d. Report any problems on DA Form 2404.

### Section III. GENERAL MAINTENANCE INSTRUCTIONS

Paragraph Number	Paragraph Title	Page Number
4-7.	General .....	4-4
4-8.	Work Safety .....	4-5
4-9.	Cleaning Instructions .....	4-6
4-10.	Preservation of Pans .....	4-8
4-11.	Painting .....	4-8
4-12.	Inspection Instructions .....	4-8
4-13.	Disassembly and Assembly Instructions .....	4-9
4-14.	Repair Instructions.. .....	4-9
4-15.	Lubrication Instructions .....	4-9
4-16.	Application of Adhesives .....	4-9
4-17.	Tool Requirements .....	4-10
4-18.	Tagging Wires and Hoses.. .....	4-11
4-19.	Soldering .....	4-11
4-20.	Heat Shrink able Tubing .....	4-11
4-21.	Electrical Ground Points .....	4-12
4-22.	Lines and Ports .....	4-12
4-23.	Airbrake System Leakage Check .....	4-13
4-24.	Antiseize Tape .....	4-13
4-25.	Fluid Disposal .....	4-13
4-26.	Electrical Repair .....	4-14

---

#### 4-7. GENERAL.

---

a. These general maintenance instructions contain general shop practices and specific methods you must be familiar with to properly maintain the M1022A1 Dolly Set. You should read and understand these practices and methods before performing any Unit Maintenance procedures.

b. Before beginning a task, find out how much repair, modification, or replacement is needed to fix the equipment. Sometimes the reason for equipment failure can be seen right away and complete teardown is not necessary. Disassemble equipment only as far as necessary to repair or replace damaged parts.

c. In some cases, a part may be damaged during removal. If the part appears to be good, and other parts behind it are not defective, leave it in place and continue with the procedure. Here are a few simple rules:

(1) Do not remove studs unless loose, bent, broken, or otherwise damaged.

(2) Do not remove bearings or bushings unless damaged. If you need to remove them to access pans behind, carefully pull out bearings and bushings.

(3) Replace all gaskets, lockwashers, locknuts, seals, cotter pins, and preformed packings.

---

**4-7. GENERAL (Con't).**

---

- d. The following “Initial Setup” information applies to all maintenance procedures:
  - (1) Resources are not listed unless they apply to the procedure.
  - (2) “Personnel Required” is listed only if more than one mechanic is required to complete the procedure.
- e. All tags and forms attached to the equipment must be checked to learn the reason for removal of equipment from service. Modification Work Orders (MWOs) and Technical Bulletins (TBs) must also be checked for equipment changes and updates.

---

**4-8. WORK SAFETY**

---

- a. Before beginning a procedure, think about the safety risks and hazards to yourself and to others. Wear protective gear such as safety goggles or lenses, safety shoes, rubber apron, or gloves.
- b. Observe all WARNINGS and CAUTIONS.
- c. When lifting heavy parts, have someone help you. Ensure that lifting equipment or jack is working properly, that it meets weight requirement of part being lifted, and that it is securely fastened to part.
- d. Immediately clean up spilled fluids to avoid slipping.
- e. Always use power tools carefully.
- f. Before beginning a procedure, ensure that the following conditions have been observed, unless otherwise specified:
  - (1) Dolly set must be parked on level ground with parking brakes applied. If parking brakes are not available, chock wheels.
  - (2) When troubleshooting an electrical malfunction or performing electrical maintenance on either dolly set lighting system or engine, disconnect either intervehicular cable or battery negative (-) ground cable (see paragraph 2-7 or 4-45).
  - (3) Before disconnecting any air line:
    - (a) Apply parking brakes and chock wheels.
    - (b) Disconnect intervehicular gladhands from towing vehicle (see paragraph 2-7).
    - (c) Drain air reservoir (see paragraph 3-6).
    - (d) Crack line before disconnection to release any trapped air.
  - (4) Before disconnecting any hydraulic line:
    - (a) Lower dolly set to the ground, and detach front and rear dollies (see paragraph 2-6).
    - (b) Fully retract lift and positioning cylinders (see paragraph 2-21).

---

#### 4-8. WORK SAFETY (Con't).

---

- (c) Shut down engine (see paragraph 2-20).
- (d) Crack line to control hydraulic fluid spills.
- (5) Before performing maintenance on engine:
  - (a) Shut down engine and set starter switch to OFF position (see paragraph 2-20).
  - (b) If working on fuel or electrical components, disconnect battery negative (-) ground cable (see paragraph 4-45).
  - (c) DO NOT smoke when working with fuel system.
  - (d) Allow engine to cool, unless otherwise specified.

---

#### 4-9. CLEANING INSTRUCTIONS.

---



Improper cleaning methods and use of unauthorized cleaning liquids or solvents can injure personnel and damage equipment. To prevent this, refer to TM 9-247 for further instructions.

a. General. Cleaning instructions will be the same for the majority of pans and components which make up the dolly set. The following applies to all cleaning operations:

- (1) Clean all parts before inspection, after repair, and before assembly.
- (2) Keep hands free of grease which can collect dust, dirt, and grit.
- (3) After cleaning, all pans should be covered or wrapped to protect them from dust and dirt. Parts that are subject to rust should be lightly oiled after cleaning (see paragraph 4-10).

b. Steam Cleaning.

**CAUTION**

DO NOT direct water or steam, under pressure, against unsealed electrical systems or any exterior opening. Failure to follow this caution may result in damage to equipment.

- (1) Before steam cleaning the doily set, protect all electrical equipment which could be damaged by steam or moisture.

---

**4-9. CLEANING INSTRUCTIONS (Con't).**


---



Avoid contact with live steam. Live steam can burn skin, cause blindness, and cause other serious injuries. Wear protective goggles, gloves, and apron when using live steam.

(2) Place disassembled pans in a suitable container to steam clean. Pans that are subject to rust should be dried and lightly oiled after cleaning (see paragraph 4-10).

c. Castings, Forgings, and Machined Metal Parts.



Dry cleaning solvent, P-D-680, is toxic and flammable. Always wear protective goggles and gloves, and use only in a well-ventilated area. Avoid contact with skin, eyes, and clothes, and DO NOT breathe vapors. DO NOT use near open flame or excessive heat. The solvent's flash point is 100°F-138°F (38°C-59°C). If you become dizzy while using cleaning solvent, immediately get fresh air and medical help. If solvent contacts eyes, immediately wash your eyes and seek medical attention.

(1) Clean inner and outer surfaces with dry cleaning solvent (Item 27, Appendix F) and dry with clean rags (Item 25, Appendix P).

(2) Remove grease and accumulated deposits with a scrub brush (Item 3, Appendix F).



Compressed air used for cleaning or drying purposes, or for clearing restrictions, should never exceed 30 psi (207 kPa). Wear protective clothing (goggles/shield, gloves, etc.) and use caution to avoid injury to personnel.

(3) Clean ail threaded holes with compressed air to remove din and cleaning fluids.

**CAUTION**

DO NOT wash oil seals, electrical cables, and flexible hoses with dry cleaning solvent or mineral spirits. Serious damage or destruction of material will result.

d. Oil Seals, Electrical Cables, and Flexible Hoses. Wash oil seals, electrical cables, and flexible hoses with a solution of detergent (Item 13, Appendix F) and water, and wipe dry with a clean rag (Item 25, Appendix F).

---

#### 4-9. CLEANING INSTRUCTIONS (Con't).

---

- e. Bearings. Clean bearings in accordance with TM 9-214.
- f. General Cleaning Covered by Other Manuals. Refer to TM 9-247, Materials Used for Cleaning, Preserving, Abrading and Cementing Ordnance Materiel and Related Materials Including Chemicals, for additional cleaning instructions.

---

#### 4-10. PRESERVATION OF PARTS.

---

Unpainted metal parts that will not be installed immediately after cleaning may be covered with a thin coat of lubricating oil (Item 23, Appendix F).

---

#### 4-11. PAINTING.

---

- a. On painted areas where paint has been removed, paint in accordance with procedures outlined in TM 43-0139 and TB 43-0209.
- b. For camouflage painting instructions, refer to FM 20-3.

---

#### 4-12. INSPECTION INSTRUCTIONS.

---

##### NOTE

All damaged areas should be marked for repair or replacement.

- a. All components and parts must be carefully checked to determine if they are serviceable for use, can be repaired, or must be scrapped.
- b. Inspect drilled and tapped (threaded) holes for the following:
  - (1) Wear, distortion, cracks, and any other damage in or around holes.
  - (2) Threaded areas for wear distortion (stretching) and evidence of cross-threading.
- c. Inspect metal lines, flexible lines or hoses, and metal fittings and connectors for the following:
  - (1) Metal lines for sharp kinks, cracks, bad bends, and dents.
  - (2) Flexible lines or hoses for fraying, evidence of leakage, and loose metal fittings or connectors.
  - (3) Metal fittings and connectors for thread damage and worn or rounded hex heads.
- d. Inspect castings, forgings, and machined metal parts for the following:
  - (1) Machined surfaces for nicks, burrs, raised metal wear, and corrosion.
  - (2) Inner and outer surfaces for breaks and cracks.
- e. Inspect bearings in accordance with TM 9-214.

---

**4-13. DISASSEMBLY AND ASSEMBLY INSTRUCTIONS.**

---

Follow these general practices when performing disassembly and assembly procedures:

- (1) Keep major components together whenever possible and practical.
- (2) Tag hoses, electrical wires, cables, and harnesses to identify them and aid during installation.
- (3) Keep related parts together for identification purposes.
- (4) Temporarily install attaching hardware such as screws, bolts, washers, and nuts to prevent loss.
- (5) Only disassemble to the point of the problem.
- (6) Ensure that parts are clean and lubricated before assembly.

---

**4-14. REPAIR INSTRUCTIONS.**

---

a. Repair castings, forgings, and machined parts using the following instructions:

- (1) Repair minor cracked castings or forgings in accordance with TM 9-237.
- (2) Repair minor damage to machined surfaces with an abrasive cloth (Item 5, Appendix F).
- (3) Replace any deeply nicked machined surface that could affect the assembly operation.
- (4) Repair minor damage to threaded capscrew holes with thread tap of same size to prevent cutting

oversize.

b. After repair, thoroughly clean all parts to prevent dirt, metal chips, or other foreign material from entering any working parts.

---

**4-15. LUBRICATION INSTRUCTIONS.**

---

Refer to Chapter 3, Section I for detailed, illustrated instructions on proper lubrication. Some general practices to remember:

- (1) Use the correct lubricant.
- (2) Keep lubricants clean.
- (3) Clean all fittings prior to lubrication.
- (4) Clean and lubricate disassembled and new parts to prevent rust (see paragraph 4-10).

---

**4-16. APPLICATION OF ADHESIVES.**

---

a. General. Adhesives are recommended in some tasks to ensure and strengthen seals. The following information describes their correct use and application.

---

#### 4-16. APPLICATION OF ADHESIVES (Con't).

---

b. Silicone Compound. Silicone compound (Item 12, Appendix F) is used to seal parts against moisture. Use the following instructions when applying:

- (1) Anytime a seal is broken, the part must be thoroughly cleaned to remove any remaining sealing compound and dirt.
- (2) Thoroughly clean surface before applying silicone compound.
- (3) When applying silicone compound, ensure that the area is completely covered. Press silicone compound into and around parts as necessary.
- (4) Silicone compound will set in 15-30 minutes depending on temperature and humidity.

c. Sealing Compound. Sealing compound (Items 10 and 11, Appendix F) provides a seal against leakage and a resistance to loosening when used in the assembly of threaded, slip-fitted, or press-fitted parts. Always use grade of sealing compound specified and never use when other retaining means are provided, such as lockwires, lockwashers, lockplates, and fasteners. DO NOT use sealing compound on brass fittings, plugs, or items that need frequent servicing, or when operating temperatures exceed 300°F (149°C). Apply sealing compound as follows:

- (1) Before application, clean threads to remove oil, grease, and metal chips.
- (2) Apply sealing compound to second and third threads. DO NOT apply to first thread to ensure system cleanliness.
- (3) Sealing compound will dry in 6-24 hours at room temperature.
- (4) Adjustments for elbows, gages, and valves can be made up to 24 hours after application without affecting the seal.

---

#### 4-17. TOOL REQUIREMENTS.

---

a. The following are general practices regarding the use of tools:

- (1) Always use the proper tool kit and tools for the procedure being performed.
- (2) Ensure that tools are clean and serviceable.
- (3) Return tools to toolbox when finished with repair or maintenance.
- (4) Inventory tools before and after each use.
- (5) Return toolboxes and tools to tool storage when not in use.

b. Some maintenance tasks may require special or fabricated tools. The "Initial Setup" of the procedure will specify any special or fabricated tools needed to perform that procedure. Use these special tools only for the maintenance procedures for which they are designed or called out. If you are unfamiliar with a required tool, see your supervisor.



---

#### 4-18. TAGGING WIRES AND HOSES.

---

- a. Use marker tags (Item 28, Appendix F) to identify all electrical wires and all air, hydraulic, fuel, and oil hoses and lines, and any other parts which may be hard to identify or replace later. Fasten tags to parts during removal by wrapping wire fasteners around or through parts and twisting ends together. Position tags to be out of the way during cleaning, inspection, and repair. Mark tags with a pencil, pen, or marker.
- b. Whenever possible, identify electrical wires with the number of the terminal or wire to which it connects. If no markings can be found, tag both wires or wire and terminal, and use the same identifying mark for both. If you cannot tag a wire because it must fit through a small hole or you cannot reach it, write down the description of the wire and the point to which it connects or draw a simple diagram on paper. Be sure to write down enough information so you will be able to properly connect the wires during assembly. If you need to identify a loose wire, look for identifying numbers near the end of the wire, stamped on a permanent metal tag. Compare this number to wire numbers on the appropriate electrical schematic.
- c. Identify air, hydraulic, fuel, and oil hoses and lines when you are taking off more than one line at the same time. Mark tags with points to which lines and hoses must be connected. If it is not obvious which end of a line goes where, tag each end of the line.
- d. Identify and tag other parts as required by name and installed location.

---

#### 4-19. SOLDERING.

---

- a. Solder connection must be bright and clean before soldering. Remove dirt and grease with a wire brush (Item 4, Appendix F) or a pocket knife (Item 30, Appendix G). Solder used must be of lead alloy (Item 26, Appendix F) with soldering flux (Item 16, Appendix F). All wires, parts, and soldering gun (Item 25, Appendix G) must be tinned for good connection and maximum transfer of heat.
- b. To prevent overheating damage to electrical parts when soldering and unsoldering connections, hold bare wire, lead, or terminal lug close to soldering point with long roundnose pliers (Item 30, Appendix G). Pliers act as heat sink and absorb excess heat.

---

#### 4-20. HEAT SHRINKABLE TUBING.

---

Use heat shrinkable tubing (Item 20, Appendix F) to insulate soldered and crimped electrical connections as follows:

- (1) Cut length of new heat shrinkable tubing twice the length of the connection to be covered.
- (2) Slide the heat shrinkable tubing onto the wire and out of the way before making electrical connection.
- (3) After making electrical connection, slide heat shrinkable tubing into place over electrical connection.

**WARNING**

DO NOT touch heat shrinkable tubing for at least 30 seconds after heating. Heat shrinkable tubing is hot and will burn you.

- (4) Hold air blow gun (Item 14, Appendix G) 4-5 in. (10.2-12.7 cm) away from heat shrinkable tubing and apply heat for approximately 30 seconds. Stop applying heat as soon as heat shrinkable tubing forms to the shape of the electrical connection.

---

## 4-21. ELECTRICAL GROUND POINTS.

---

Many electrical problems are the result of poor ground connections. You can ensure that ground connections are good by performing the following steps:

**WARNING**

When troubleshooting an electrical malfunction or performing electrical maintenance on either dolly set lighting system or engine, disconnect either intervehicular cable or battery negative (-) ground cable. Failure to do so may create a spark and electrical shock, resulting in serious injury to personnel.

- (1) Remove hardware connecting ground cable terminal lug to ground point.



Dry cleaning solvent, P-D-680, is toxic and flammable. Always wear protective goggles and gloves, and use only in a well-ventilated area. Avoid contact with skin, eyes, and clothes, and DO NOT breathe vapors. DO NOT use near open flame or excessive heat. The solvent's flash point is 100°F-138°F (38°C-59°C). If you become dizzy while using cleaning solvent, immediately get fresh air and medical help. If solvent contacts eyes, immediately wash your eyes and seek medical attention.

- (2) Clean mounting hardware, ground cable terminal lugs, and ground point with dry cleaning solvent (Item 27, Appendix F) and scrub brush (Item 3, Appendix F).
- (3) Remove any rust with wire brush (Item 4, Appendix F) and crocus cloth (Item 6, Appendix F).
- (4) Look for cracks, loose terminal lugs, and stripped threads. Replace any defective parts.
- (5) Install hardware connecting ground cable terminal lug to ground point. Ensure that all hardware is tight.

---

## 4-22. LINES AND PORTS.

---

To keep dirt from contaminating systems when removing and installing air, hydraulic, fuel, and oil hoses and lines, perform the following steps:

- (1) Clean fittings and surrounding area before disconnecting lines.
- (2) Cover, cap, plug, or tape lines and ports after disconnecting lines. When these are not available, use hand-carved wooden plugs, clean rags (Item 25, Appendix F), duct tape (Item 30, Appendix F), or other similar materials to prevent dirt from entering system.
- (3) Ensure that new and used parts are clean before installing.
- (4) Wait to remove cover, cap, plug, or tape from lines and ports until just before installing lines.

---

#### 4-23. AIRBRAKE SYSTEM LEAKAGE CHECK.

---

- a. Connect intervehicular and intradolly gladhands (see paragraph 2-11).
- b. Fully pressurize dolly set airbrake system (see towing vehicle Operator's Manual).
- c. Apply a solution of detergent (Item 13, Appendix F) and water to front and rear dolly gladhands, air hoses, fittings, air reservoirs, brake chambers, and valves.
- d. Make note of any leaks, damage, or loose connections found. Tighten loose connections and replace damaged components.

---

#### 4-24. ANTISEIZE TAPE.

---

When connecting air hoses and fittings without compression sleeves or packings, antiseize tape (Item 29, Appendix F) may be used to keep connections from leaking. Use as follows:

**CAUTION**

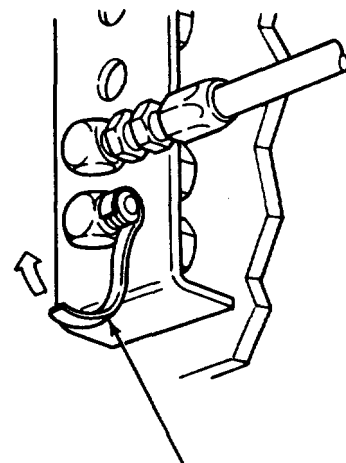
If threads are not clean and dry and antiseize tape is not clean, leaks can occur.

- (1) Ensure that threads are clean and dry and antiseize tape is clean,
- (2) Start antiseize tape one or two threads from small or leading edge of fitting, joining tape together with an overlap of about 1/8 in. (3.18 mm) for fittings with fine threads. For fittings with coarse threads, tape should be wrapped around threads two or three times.
- (3) Tightly wrap antiseize tape in same direction as you would tighten a nut. Tape must be pressed into threads without cutting or ripping.

**CAUTION**

DO NOT exceed specified torque or use power tools to tighten fittings taped with antiseize tape. Overtightening could damage fitting threads and cause connection to leak.

- (4) Using hand tools, tighten fittings to specified torque.



**ANTISEIZE TAPE**

---

#### 4-25. FLUID DISPOSAL.

---

Dispose of contaminated drained fluids in accordance with the Standard Operating Procedures (SOP) of your unit.

---

## 4-26. ELECTRICAL REPAIR.

---

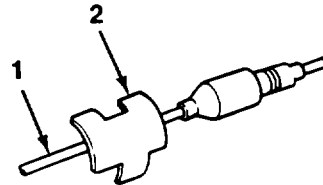
a. General. Specific electrical system maintenance tasks are covered in Section VI of this chapter. The following are general electrical practices and procedures.

b. Identification Band Replacement.

(1) Remove identification band (2) from wire lead (1) and discard.

(2) Mark new identification band (2) with proper identification number.

(3) Position new identification band (2) on wire lead (1) and bend tabs over wire lead.

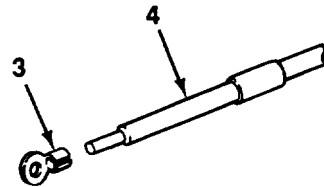


c. Terminal Lead Replacement.

(1) Cut terminal lead (3) off wire lead (4) and discard.

(2) Remove insulation from wire lead (4) equal to depth of new terminal lead (3).

(3) Position new terminal lead (3) on wire lead (4) and crimp (Item 29, Appendix G).



d. Male Connector Repair.

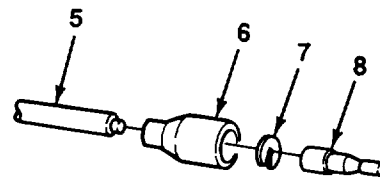
(1) Slide back shell (6) and remove washer (7) from wire lead (5). Cut ferrule (8) from wire lead and discard. Remove shell.

(2) Remove insulation from wire lead (5) equal to depth of new ferrule (8).

(3) Slide shell (6) on wire lead (5).

(4) Position new ferrule (8) on wire lead (5) and crimp (Item 29, Appendix G).

(5) Position washer (7) on wire lead (5) near crimping. Slide shell (6) over washer and ferrule (8).



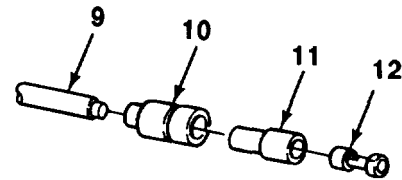
---

## 4-26. ELECTRICAL REPAIR (Con't).

---

### e. Female Connector Repair.

- (1) Slide back shell (10) and sleeve (11), and cut terminal (12) from wire lead (9). Discard terminal.
- (2) Remove sleeve (11) and shell (10) from wire lead (9).
- (3) Remove insulation from wire lead (9) equal to depth of new terminal (12).
- (4) Slide shell (10) and sleeve (11) on wire lead (9).
- (5) Position new terminal (12) on wire lead (9) and crimp (Item 29, Appendix G).
- (6) Slide sleeve (11) and shell (10) over terminal (12).



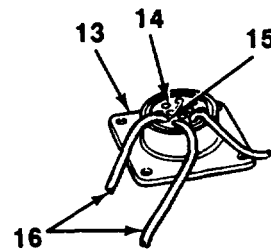
### f. Receptacle Connector Repair.

#### NOTE

Male and female receptacle connectors are repaired the same way. Male connector is illustrated.

- (1) Use soldering gun (Item 25, Appendix G) to heat soldered connections (15). Disconnect wires (16) from pin locations (14) of receptacle connector (13).

- (2) Position new wires (16) at appropriate pin locations (14). Solder connections using solder (Item 26, Appendix F) and soldering gun (Item 25, Appendix G).



## Section IV. UNIT PREVENTIVE MAINTENANCE CHECKS AND SERVICES (PMCS)

Paragraph Number	Paragraph Title	Page Number
4-27.	General.....	4-16
4-28.	Explanation of PMCS Table Entries .....	4-16
4-29.	General PMCS Procedures .....	4-17
Table 4-1.	Unit Preventive Maintenance Checks and Services (PMCS) .....	4-18

---

### 4-27. GENERAL.

---

To ensure that the M1022A1 Dolly Set is ready for operation at all times, it must be inspected on a regular basis so that defects may be found before they result in serious damage, equipment failure, or injury to personnel. Table 4-1 contains systematic instructions on inspections, adjustments, and corrections to be performed by Unit Maintenance to keep the dolly set in good operating condition and ready for its primary mission.

---

### 4-28. EXPLANATION OF TABLE ENTRIES.

---

a. Item Number (Item No.) Column. Numbers in this column are for reference. When completing DA Form 2404 (Equipment Inspection and Maintenance Worksheet), include the item number for the check/service indicating a fault. Item numbers also appear in the order that you must perform checks and services for the interval listed.

b. Interval Column. This column tells you when you must perform the procedure in the procedure column.

- (1) Semiannually procedures must be done once every six months.
- (2) Annually procedures must be done once each year.
- (3) Biennially procedures must be done once every two years.

c. Location, Item To Check/Service Column. This column identifies the location and the item to be checked or serviced. The item location is underlined.

#### NOTE

The WARNINGS and CAUTIONS appearing in your PMCS table should always be observed. WARNINGS and CAUTIONS appear before applicable procedures. These WARNINGS and CAUTIONS must be observed to prevent serious injury to yourself and others or to prevent your equipment from being damaged.

d. Procedure Column. This column gives the procedure you must perform to check or service the item listed in the item To Check/Service column to know if the equipment is ready or available for its intended mission or for operation. You must perform the procedure at the time stated in the interval column.

---

#### 4-28. EXPLANATION OF TABLE ENTRIES (Con't).

---

e. Not Fully Mission Capable If: Column. Information in this column tells you what faults will keep your equipment from being capable of performing its primary mission. If you make check and service procedures that show faults listed in this column, the equipment is not mission-capable. Follow standard operating procedures for maintaining the equipment or reporting equipment failure.

---

#### 4-29. GENERAL PMCS PROCEDURES.

---

a. Always perform PMCS in the same order so it gets to be a habit. Once you've had some practice, you'll spot anything wrong in a hurry. If any deficiency is discovered, perform the appropriate troubleshooting task in Chapter 4, Section V. If any component or system is not serviceable, or if the given service does not correct the deficiency, notify your supervisor.

b. Before performing preventive maintenance, read all the checks required for the applicable interval and prepare all tools needed to make all checks. Have several clean rags (Item 25, Appendix F) handy. Perform AU inspections at the applicable interval.



Dry cleaning solvent, P-D-680, is toxic and flammable. Always wear protective goggles and gloves, and use only in a well-ventilated area. Avoid contact with skin, eyes, and clothes, and DO NOT breathe vapors. DO NOT use near open flame or excessive heat. The solvent's flash point is 100°F-138°F (36°C-59°C). If you become dizzy while using cleaning solvent, immediately get fresh air and medical help. If solvent contacts eyes, immediately wash your eyes and seek medical attention.

(1) **Keep It Clean.** Dirt, grease, oil, and debris get in the way and may cover up a serious problem. Clean as you work and as needed. Use dry cleaning solvent (Item 27, Appendix F) on all metal surfaces. Use dishwashing compound (Item 7, Appendix F) and water when you clean rubber, plastic, and painted surfaces.

(2) **Rust and Corrosion.** Check metal parts of the dolly set and frame for rust and corrosion. If any bare metal or corrosion exists, clean and apply a light coat of lubricating oil (see paragraph 4-10). Report it to your supervisor.

(3) **Bolts, Nuts, and Screws.** Check bolts, nuts, and screws for obvious looseness, missing, bent, or broken condition. You can't try them all with a tool, of course, but look for chipped paint, bare metal, or rust around bolt heads. If you find one you think is loose, tighten it.

(4) **Welds.** Look for loose or chipped paint, rust, or gaps where parts are welded together. If you find a bad weld, report it to your supervisor.

(5) **Electric Wires and Connectors.** Look for cracked or broken insulation, bare wires, and loose or broken connectors. Tighten loose connectors and ensure that the wires are in good condition.

(6) **Hydraulic Hoses and Lines.** Look for wear, damage, and signs of leaks. Ensure that clamps and fittings are tight. Wet spots indicate leaks, of course, but a stain around a fitting or connector can also mean a leak. If a leak comes from a loose fitting or connector, tighten it. If something is broken or worn out, correct it if authorized by the Maintenance Allocation Chart (Appendix B). If not authorized, report it to your supervisor.

**4-29. GENERAL PMCS PROCEDURES (Con't).**

(7) Fluid Leakage. It is necessary for you to know how fluid leakage affects the status of your dolly set. The following are definitions of the types/classes of leakage you need to know to be able to determine whether or not the dolly set is mission-capable. Learn and be familiar with them, and remember - when in doubt, notify your supervisor!

**CAUTION**

Equipment operation is allowable with minor (Class I or II) leakage. Fluid levels in an item/system affected with such leakage must be checked more frequently than required in PMCS. Parts without fluid will stop working or may be damaged. When in doubt, notify your supervisor. IMMEDIATELY report Class III leaks to your supervisor.

Leakage Definitions for PMCS

- Class I . . . . . Seepage of fluid (as indicated by wetness or discoloration) not great enough to form drops.
- Class II . . . . . Leakage of fluid great enough to form drops, but not enough to cause drops to drip from the item being inspected.
- Class III . . . . . Leakage of fluid great enough to form drops that fall from the item being inspected.

Table 4-1. Unit Preventive Maintenance Checks and Services (PMCS).

Item No.	Interval	Location	Procedure	Not Fully Mission Capable If:
		Item To Check/Service		
1	Semiannually	Engine Crankcase	<p>NOTE</p> <p>The following checks, except where noted, must be performed on BOTH front and rear dollies.</p> <p>Drain oil from crankcase and remove oil filter. Clean or replace oil filter as required. Fill crankcase with oil (see Lubrication Instructions, Chapter 3, Section I).</p>	



Table 4-1. Unit Preventive Maintenance Checks and Services (PMCS) (Con't).



Item No.	Interval	Location	Procedure	Not Fully Mission Capable If:
		Item To Check/Service		
2	Semiannually	Engine Air Cleaner Element	<div style="text-align: center;">  <div style="border: 1px solid black; padding: 2px; display: inline-block; margin-left: 20px;"><b>WARNING</b></div> </div> <p>If NBC exposure is suspected, all engine air cleaner air filter media should be handled by personnel wearing protective equipment. Consult your NBC Officer or NBC NCO for appropriate handling or disposal procedures.</p> <p>Remove air cleaner element from air cleaner and clean (see paragraph 3-10).</p>	
3	Semiannually	Fuel Tank	<div style="text-align: center;">  <div style="border: 1px solid black; padding: 2px; display: inline-block; margin-left: 20px;"><b>WARNING</b></div> </div> <p>Diesel fuel is combustible. DO NOT smoke or allow an open flame near fuel tank. Shut down engine when adding fuel. Failure to follow this warning will result in serious injury or death to personnel. If you are burned, immediately seek medical attention.</p> <p>Drain fuel tank and remove fuel filter and strainer. Clean or replace fuel filter and strainer as required. Fill fuel tank (see paragraph 4-125).</p>	

Table 4-1. Unit Preventive Maintenance Checks and Services (PMCS) (Con't).




Item No.	Interval	Location Item To Check/ Service	Procedure	Not Fully Mission Capable If:
4	Semiannually	Batteries	<div style="display: flex; justify-content: space-around; align-items: center;">   <div style="border: 1px solid black; padding: 2px; text-align: center;"><b>WARNING</b></div>  </div> <ul style="list-style-type: none"> <li>• Remove all jewelry such as I.D. tags, rings, bracelets, etc. If jewelry contacts battery terminal, a direct short will result causing instant heating of jewelry which will result in serious injury or death to personnel.</li> <li>• Battery acid (electrolyte) is extremely dangerous. Always wear protective goggles and rubber gloves when performing battery checks or inspections. Serious injury to personnel will result if battery acid contacts skin or eyes.</li> <li>• DO NOT perform battery system checks or inspections while smoking or near fire, flames, or sparks. Battery gases may explode, causing serious injury or death to personnel.</li> </ul> <p>Test and service batteries in accordance with TM 9-6140-200-14.</p>	
5	Semiannually	Tie-rod Assemblies (Front Dolly)	<p>a. Check for cracks, breaks, or bends to tie-rod assemblies. Check for security of mounting. Replace if damaged (see paragraph 4-77).</p> <p>b. Lubricate tie-rod assemblies (see Lubrication Instructions, Chapter 3, Section I).</p>	a. Tie-rod assembly is damaged or is not secure.

Table 4-1. Unit Preventive Maintenance Checks and Services (PMCS) (Con't).

Item No.	Interval	Location	Procedure	Not Fully Mission Capable If:
		Item To Check/Service		
6	Semiannually	Steering Knuckle Assembly (Front Dolly)	<p>a. Check for damage to steering knuckle assembly. Replace if damaged (see paragraph 4-54).</p> <p>b. Lubricate steering knuckle assembly (see Lubrication Instructions, Chapter 3, Section I).</p>	a. Steering knuckle assembly is damaged.
7	Semiannually	Steering Link (Front Dolly)	<p>a. Check for cracks, breaks, or bends in steering link. Check for security of mounting. Replace if damaged (see paragraph 4-78).</p> <p>b. Lubricate steering link (see Lubrication Instructions, Chapter 3, Section I).</p>	a. Steering link is damaged or is not secure.
8	Semiannually	Front Drawbar (Front Dolly)	<p>a. Check for cracks, breaks, bad welds, or bends in front drawbar. Check all components installed on front drawbar for security of mounting.</p> <p>b. Lubricate front drawbar (see Lubrication Instructions, Chapter 3, Section I).</p>	a. Front drawbar is damaged or is not secure.
9	Semiannually	Caster Wheel Assembly	<p>a. Lubricate caster wheel assembly (see Lubrication Instructions, Chapter 3, Section I).</p> <p>b. Check caster wheel assembly tire for inflation of 95 psi (666 kPa).</p>	
10	Semiannually	Tire and Wheel Assemblies	<p>a. Check for abnormal, uneven, or other damage to tires (see TM 9-2610-200-14). Check tires for proper inflation (see paragraph 1-15).</p> <p>b. Check lug nuts for looseness. Tighten to specified torque (see paragraph 4-76).</p>	
11	Semiannually	Pivoting Tray	Lubricate pivoting tray bearings (see Lubrication Instructions, Chapter 3, Section I).	

Table 4-1. Unit Preventive Maintenance Checks and Services (PMCS) (Con't).

tam No.	Interval	Location Item To Check/ Service	Procedure	Not Fully Mission Capable If:
12	Semiannually	Lift Cylinders	Lubricate lift cylinders (see Lubrication Instructions, Chapter 3, Section I).	
13	Semiannually	Pivot Axle Bracket Lockout Brackets	Check that lockout bracket assemblies are properly and securely installed. (see paragraph 4-82).	
14	Semiannually	Hydraulic Lines and Fittings	<div style="text-align: center; border: 1px solid black; padding: 5px; width: fit-content; margin: 0 auto;"> <b>WARNING</b> </div> <p>DO NOT disconnect hydraulic lines and fittings while engine is running or before hydraulic system pressure has been released. When engine is running, hydraulic system is under pressure. Dolly set must be fully lowered to the ground and engine must be shut down before lines and fittings are disconnected. A line or fitting disconnected under pressure will explode with great force and cause serious injury to personnel.</p>	

Table 4-1. Unit Preventive Maintenance Checks and Services (PMCS) (Con't).

Item No.	Interval	Location	Procedure	Not Fully Mission Capable If:
		Item To Check/Service		
14 (Con't)	Semiannually	Hydraulic Lines and Fittings	<div style="border: 1px solid black; padding: 2px; text-align: center; margin-bottom: 10px;"><b>WARNING</b></div> <p>Escaping hydraulic fluid under pressure can penetrate the skin, causing serious injury to personnel. Relieve pressure before disconnecting hydraulic lines and fittings. Tighten all connections before applying pressure. Keep hands and body away from pinholes and nozzles which eject hydraulic fluid under high pressure. Use a piece of cardboard or paper to search for leaks. If any hydraulic fluid is injected into the skin, it <b>MUST</b> be surgically removed within a few hours by a doctor familiar with this type of injury or gangrene may result.</p> <p>Start engine (see paragraph 2-20). Operate hydraulic control valve (see paragraph 2-21) and inspect all hydraulic lines and fittings for signs of leaks. Tighten any connections that are loose. Ensure that hydraulic lines are properly supported and protectively wrapped, as required. Replace any damaged component.</p>	Components are damaged. Class III leakage is evident.

Table 4-1. Unit Preventive Maintenance Checks and Services (PMCS) (Con't).





Item No.	Interval	Location Item To Check/ Service	Procedure	Not Fully Mission Capable If:
15	Annually	Cylinder Cowling and Spiral Case	  <p>Compressed air used for cleaning or drying purposes, or for clearing restrictions, should never exceed 30 psi (207 kPa). Wear protective clothing (goggles/shield, gloves, etc.) and use caution to avoid injury to personnel.</p> <p>Remove cylinder cowling and spiral case. Use compressed air to remove all sand, dirt, or other debris from cylinder fins and flywheel assembly. Install cylinder cowling and spiral case (see paragraph 4-128).</p>	
16	Annually	Engine Air Cleaner Element	  <p>If NBC exposure is suspected, all engine air cleaner air filter media should be handled by personnel wearing protective equipment. Consult your NBC Officer or NBC NCO for appropriate handling or disposal procedures.</p> <p>Replace air cleaner element (see paragraph 4-123).</p>	

Table 4-1. Unit Preventive Maintenance Checks and Services (PMCS) (Con't).

Item No.	Interval	Location	Procedure	Not Fully Mission Capable If:
		Item to Check/Service		
17	Annually	Service Brakes	Perform minor brake adjustment (see paragraph 4-59).	
18	Annually	Hub, Brake-drum, and Wheel Bearings	Remove hub, brakedrum, and wheel bearings. Clean and inspect bearing cones and cups in accordance with TM 9-214. Inspect brakeshoe linings for damage and wear. Install hub, brakedrum, and wheel bearings. Perform wheel bearing adjustment (see paragraph 4-75).	
<b>NOTE</b>				
<b>Perform procedure one clevis pin at a time. Two personnel are required.</b>				
18.1	Annually	Suspension Link-to-Bottom Beam Clevis Pins	Support end of suspension link. Remove cotter pin, flatwasher and clevis pin (see paragraph 4-82). Clean clevis pin and inspect for corrosion or roughness. If corroded or rough use lubricating oil (Item 23, Appendix F) and abrasive cloth (Item 6, Appendix F) to clean and remove roughness. Reinstall clevis pin, flatwasher( and cotter pin. Remove support from end of suspension link.	
18.2	Annually	Pivot Axle Lockout Bracket Bolts	Remove lockout brackets and inspect bolts for corrosion. As required, clean bolts with abrasive cloth (Item 6, Appendix F) and lubricating oil (Item 23, Appendix F). Reinstall lockout brackets (see paragraph 4-82).	
19	Biennially	Fuel Lines	Replace flexible fuel lines (see paragraph 4-122).	
20	Biennially	Oil Cooler Lines	Replace oil cooler lines (see paragraph 4-119).	

## Section V. UNIT TROUBLESHOOTING PROCEDURES

Paragraph Number	Paragraph Title	Page Number
4-30.	General .....	4-26
4-31.	Explanation of Columns .....	4-26
4-32.	Troubleshooting Symptom Index .....	4-27
Table 4-2.	Unit Troubleshooting .....	4-28

---

### 4-30. GENERAL.

---

a. This section provides information for identifying and correcting malfunctions which may develop when operating or maintaining the M10221A1 Dolly Set.

b. The Troubleshooting Symptom Index (see paragraph 4-32) lists common malfunctions which may occur and refers you to the proper page in Table 4-2 for a troubleshooting procedure.

c. This section cannot list all malfunctions that may occur, nor all tests or inspections and corrective actions. If a malfunction is not listed, or is not corrected by the listed corrective actions, notify your supervisor.

d. When troubleshooting a malfunction:

(1) Question the operator to obtain any information that might help determine the cause of the problem. Before continuing, ensure that all applicable operator/crew troubleshooting was performed.

(2) Locate the symptom or symptoms in paragraph 4-32 that best describe the malfunction. If the appropriate symptom is not listed, notify your supervisor.

(3) Turn to the page in Table 4-2 where the troubleshooting procedures for the malfunction in question are described. Headings at the top of each page show how each troubleshooting procedure is organized: Malfunction, Test or Inspection (in step number order), and Corrective Act/on.

(4) Perform each step in the order listed until the malfunction is corrected and the item being inspected is operational. Do not perform any maintenance task unless the troubleshooting procedure tells you to do so.

---

### 4-31. EXPLANATION OF COLUMNS.

---

The columns in Table 4-2 are defined as follows:

- (1) MALFUNCTION. A visual or operational indication that something is wrong with the dolly set.
- (2) TEST OR INSPECTION. A procedure to isolate the problem in a system or component,
- (3) CORRECTIVE ACTION. A procedure to correct the problem.



---

**4-32. TROUBLESHOOTING SYMPTOM INDEX.**

---

	Troubleshooting Procedure Page
<b>Brake System</b>	
Drag .....	4-35
Grab .....	4-35
No Brakes .....	4-33
Parking Brakes (Rear Dolly) Do Not:	
H o l d .....	4-36
Release .....	4-37
Slow:	
Application .....	4-34
Release .....	4-34
Uneven Brakeshoe Lining Wear .....	4-37
Weak Brakes .....	4-33
 <b>ELECTRICAL SYSTEM</b>	
Dim Lamps .....	4-32
Flickering Lamps .....	4-32
Lamps:	
Bum Out Frequently (One or More) .....	4-32
Dim .....	4-32
Fail to Light:	
All (Front and Rear Doilies) .....	4-28
One or More (But Not Ail) .....	4-30
Rear Dolly .....	4-30
Flickering.. .....	4-32
 <b>ENGINE</b>	
Battery:	
Overcharges .....	4-42
Will Not Hold Charge .....	4-41
Exhaust Observed (Excessive):	
Black .....	4-46
Blue .....	4-46
Gray, Dark .....	4-46
White .....	4-46
Full Power Not Developed .....	4-45
Misfires .....	4-45
Runs Rough .....	4-45
Turns Over But Will Not Start .....	4-43
Will Not:	
Start In Cold Weather .....	4-44
Turn Over (With Starter Switch Set to ST) .....	4-40

---

**4-32. TROUBLESHOOTING SYMPTOM INDEX (Con't).**

---

	Troubleshooting Procedure Page
<b>HYDRAULIC SYSTEM</b>	
Hydraulic System Will Not Operate .....	4-38
Lift Cylinder(s):	
Drifts .....	4-39
Will Not Operate .....	4-39
Positioning Cylinder Will Not Operate .....	4-39
<b>TIRES</b>	
Abnormal Wear .....	4-38
Uneven Wear .....	4-38

Table 4-2. Unit Troubleshooting.

---

**MALFUNCTION**

TEST OR INSPECTION

CORRECTIVE ACTION

---

**ELECTRICAL SYSTEM**

1. ALL LAMPS (FRONT AND REAR DOLLIES) FAIL TO LIGHT.

**CAUTION**

When performing a continuity test, always disconnect intervehicular cable from towing vehicle and circuit to be tested. Failure to follow this caution may damage multimeter.

**NOTE**

Refer to electrical wiring diagrams for assistance (see paragraph 4-50).

- Step 1. Troubleshoot towing vehicle electrical system. Ensure that there is power (12 v of 24 v) at pins of trailer receptacle (see towing vehicle Unit Maintenance Manual).

Repair or replace damaged components (see towing vehicle Unit Maintenance Manual).

- Step 2. Disconnect Intervehicular cable from towing vehicle and signal conditioning box (see paragraph 2-7). Check for damage to receptacle connectors at signal conditioning box.

Replace damaged receptacle connectors (see paragraph 4-34).

Table 4-2. Unit Troubleshooting (Con't).

MALFUNCTION	TEST OR INSPECTION	CORRECTIVE ACTION
	Step 3.	<p>Check for continuity in each wire of intervehicular cable. There should be continuity. Check for continuity between pins/sockets at connector plug ends. There should be no continuity.</p> <p>Replace damaged intervehicular cable.</p>
	Step 4.	<p>Disconnect intradolly cable from forward junction box and rear junction box (see paragraph 2-7). Check for damage to receptacle connectors at forward junction box and rear junction box.</p> <p>Replace damaged receptacle connectors (see paragraph 4-35 and 4-37).</p>
	Step 5.	<p>Check for continuity in each wire of intradolly cable. There should be continuity. Check for continuity between pins/sockets at connector plug ends. There should be no continuity.</p> <p>Replace damaged intradolly cable.</p>
	Step 6.	<p>Check ground wires in signal conditioning box, forward junction box, and rear junction box to ensure that they are secure. Check for looseness and damage to terminal blocks and wires inside boxes.</p> <p>Clean and tighten ground wires and other components as required (see paragraph 4-34, 4-35, and 4-37).</p>
	Step 7.	<p>Disconnect intervehicular cable from towing vehicle and signal conditioning box (see paragraph 2-7). Check for continuity in wires between J1 receptacle connector in signal conditioning box and J3 receptacle connector in forward Junction box. Check also for continuity between J2 receptacle connector in signal conditioning box and J3 receptacle connector.</p>
NOTE		
<p>Circuits containing voltage reducers will reflect high resistance in one direction. Reversing multimeter leads will result in low resistance.</p>		
		<p>When continuity in a circuit between J1 or J2 receptacle connector and J3 receptacle connector is not present, check for continuity across terminals of circuit breaker inside signal conditioning box. If there is no continuity, replace circuit breaker (see paragraph 4-34).</p>
	Step 8.	<p>Check for continuity from circuit breaker inside signal conditioning box to TB1 terminal block inside forward junction box. Check for continuity from TB1 terminal block to J3 receptacle connector.</p> <p>Replace damaged signal conditioning box-to-forward junction box cable assembly (see paragraph 4-46) or repair damaged forward junction box (see paragraph 4-35).</p>
	Step 9.	<p>If malfunction persists, perform voltage check across terminals of all circuit breakers.</p> <p>If voltage is not present, replace circuit breaker (see paragraph 4-34).</p>

Table 4-2. Unit Troubleshooting (Con't).

MALFUNCTION	TEST OR INSPECTION	CORRECTIVE ACTION
-------------	--------------------	-------------------

2. REAR DOLLY LAMPS FAIL TO LIGHT

**CAUTION**

When performing a continuity test, always disconnect intervehicular cable from towing vehicle and circuit to be tested. Failure to follow this caution may damage multimeter.

NOTE

Refer to electrical wiring diagrams for assistance (see paragraph 4-50).

- Step 1. Disconnect intradolly cable from forward junction box and rear junction box (see paragraph 2-7). Check for damage to receptacle connectors at rear junction box.

Replace damaged receptacle connectors (see paragraph 4-37).

- Step 2. Check for continuity in each wire of intradolly cable. There should be continuity. Check for continuity between pins/sockets at connector plug ends. There should be no continuity.

Replace damaged intradolly cable.

- Step 3. Check ground wires in rear junction box to ensure that they are secure. Check for looseness and damage to terminal block and wires inside box.

Clean and tighten ground wires and other components.

Replace or repair damaged rear junction box as required (see paragraph 4-37).

3. ONE OR MORE LAMPS (BUT NOT ALL) FAIL TO LIGHT.

**CAUTION**

When performing a continuity test, always disconnect intervehicular cable from towing vehicle and circuit to be tested. Failure to follow this caution may damage multimeter.

NOTE

Refer to electrical wiring diagrams for assistance (see paragraph 4-50).

- Step 1. Remove lamp from socket (see paragraph 4-38, 4-39, 4-40, or 4-42). Check lamp for damage, corrosion, and continuity.

Replace damaged lamp (see paragraph 4-38, 4-39, 4-40, or 4-42).

- Step 2. Check lamp socket for damage or corrosion. Check light for loose or corroded mounting screws or loose or damaged ground wire, if present.

Tighten all loose components. Replace damaged or corroded light (see paragraph 4-38, 4-39, 4-40, or 4-42).

Table 4-2. Unit Troubleshooting (Con't).

MALFUNCTION	TEST OR INSPECTION	CORRECTIVE ACTION
Step 3.	Check for damage to connector plug(s) of affected light.	Repair damaged connector plug(s) (see paragraph 4-26).
Step 4.	Trace Circuit between connector plug(s) at affected light and TB2 terminal block inside rear junction box (rear dolly light malfunction) or circuit breaker Inside signal conditioning box (front dolly light malfunction). Check for continuity and loose or damaged wires between affected light and rear junction box or circuit breaker inside signal conditioning box.	Tighten any loose components, connections, and ground wire. If there is no continuity, replace damaged cable assembly (see paragraph 4-47, 4-48, or 4-49).
Step 5.	If malfunction is on rear dolly, trace circuit between TB2 terminal block inside rear junction box and corresponding pin of J4 receptacle connector. Check for continuity and loose or damaged wires. Check ground wire at pin D of J4 receptacle connector for looseness.	Tighten any loose components, connections, and ground wire. If there is no continuity, replace damaged J4 receptacle connector and cable assembly (see paragraph 4-37).
Step 6.	If malfunction is on rear dolly, check for continuity in wire of intradolly cable that corresponds to malfunctioning lamp. There should be continuity. Check for continuity between pins/sockets at connector plug ends. There should be no continuity.	Replace damaged intradolly cable.
Step 7.	If malfunction is on rear dolly, trace circuit between pin at J3 receptacle connector and TB1 terminal block inside forward junction box. Check for continuity and loose or damaged wires. Check ground wire at pin D of J3 receptacle connector for looseness.	Tighten any loose components, connections, and ground wire. If there is no continuity, replace damaged J3 receptacle connector and cable assembly (see paragraph 4-35).
Step 8.	If malfunction is on rear dolly, trace circuit between TB1 terminal block in forward junction box and circuit breaker in signal conditioning box. Check for continuity and loose or damaged wires.	If there is no continuity, replace damaged signal conditioning box-to-forward junction box cable assembly (see paragraph 4-6).
Step 9.	Check for continuity in wire of intervehicular cable that corresponds to malfunctioning lamp. There should be continuity. Check for continuity between pins/sockets at connector plug ends. There should be no continuity.	Replace damaged intervehicular cable.
Step 10.	Check for continuity across terminals of circuit breaker on affected circuit.	If there is no continuity, replace damaged circuit breaker (see paragraph 4-34).

Table 4-2. Unit Troubleshooting (Con't).

MALFUNCTION	TEST OR INSPECTION	CORRECTIVE ACTION
-------------	--------------------	-------------------

Step 11. Check for continuity in wires between J1 or J2 receptacle connector in signal conditioning box and circuit breakers.

If there is no continuity, replace damaged J1 or J2 receptacle connector or repair damaged wires (see paragraph 4-34).

Step 12. If malfunction persists, perform voltage check across terminals of all circuit breakers.

If there is no voltage, replace damaged circuit breaker (see paragraph 4-34).

4. DIM OR FLICKERING LAMPS.

NOTE

Dim or flickering lamps are most often caused by loose or corroded connections. Check for these conditions while performing troubleshooting test and inspections.

Check that affected lamp is not loose in light socket (see paragraph 4-38, 4-39, 4-40, or 442).

Securely install lamp in light socket (see paragraph 4-38, 4-39, 4-40, or 4-42).

Perform steps 2 through 12 of Malfunction 3, One or More Lamps (But Not All) Fail to Light.

5. ONE OR MORE LAMPS BURN OUT FREQUENTLY.

NOTE

If one or more lamps burn out frequently or immediately after replacement, a probable cause is a failed voltage reducer inside signal conditioning box.

Step 1. Inspect voltage reducer on affected circuit inside signal conditioning box for loose or disconnected wires.

Connect and tighten wires.

Step 2. With intervehicular cable connected and towing vehicle power on (see paragraph 2-11), check voltage at output of voltage reducer on affected circuit. Voltage should be 12 v.

Replace damaged voltage reducer (see paragraph 4-34).

Table 4-2. Unit Troubleshooting (Con't).

MALFUNCTION	TEST OR INSPECTION	CORRECTIVE ACTION
-------------	--------------------	-------------------

## BRAKE SYSTEM

## 6. NO BRAKES OR WEAK BRAKES.



- DO NOT disconnect air lines and fittings while dolly set airbrake system is pressurized. Intervehicular air lines must be disconnected and air reservoirs drained before air lines and fittings are disconnected. A line or fitting disconnected under pressure may explode with great force and cause serious injury to personnel.
- Wear eye protection when working with compressed air to avoid serious eye injury.

## NOTE

Refer to airbrake system schematics for assistance (see paragraph 4-74).

- Step 1. Perform airbrake system leakage check (see paragraph 4-23).  
 Replace any leaking air line or damaged valve.
- Step 2. Check for properly adjusted brakes (see paragraph 4-59).  
 Perform minor brake adjustment (see paragraph 4-59).
- Step 3. Check for damage to airbrake chambers.  
 Replace leaking or damaged airbrake chambers (see paragraph 4-61).
- Step 4. Check for loose airbrake chambers in spider plunger housings (see paragraph 4-61).  
 Properly install airbrake chambers (see paragraph 4-61).
- Step 5. Remove hub and brakedrum (see paragraph 4-75). Inspect brakedrum and brakeshoes for damage, wear, or grease-soaked linings.  
 Replace worn brakedrum (see paragraph 4-75).  
 If grease is found on brakeshoe linings, inspect wheel seal. Replace damaged wheel seal (see paragraph 4-75).  
 Replace damaged, worn, or grease-soaked brakeshoes (see paragraph 4-57).
- Step 6. Replace spider assembly (see paragraph 4-60).

Table 4-2. Unit Troubleshooting (Con't).

MALFUNCTION	TEST OR INSPECTION	CORRECTIVE ACTION
-------------	--------------------	-------------------

Step 7. If malfunction persists during tandem towing, problem may be with booster relay valve of front dolly set. A malfunctioning booster relay valve will not adequately amplify the service brake signal to rear dolly set.

Replace damaged booster relay valve (see paragraph 4-63 or 4-67).

7. SLOW APPLICATION OR SLOW RELEASE OF BRAKES.



- DO NOT disconnect air lines and fittings while dolly set airbrake system is pressurized. Interventricular air lines must be disconnected and air reservoirs drained before air lines and fittings are disconnected. A line or fitting disconnected under pressure may explode with great force and cause serious injury to personnel.
- Wear eye protection when working with compressed air to avoid serious eye injury.

NOTE

Refer to airbrake system schematics for assistance (see paragraph 4-74).

Step 1. Perform airbrake system leakage check (see paragraph 4-23). Check all air hoses between intervehicular service air hose and airbrake chambers for leaks or other damage.

Replace damaged air lines (see paragraph 4-72 or 4-73).

Step 2. With dolly set airbrake system fully pressurized, check for defective relay emergency valve (front dolly) or full function valve (rear dolly). Apply service brakes, then release. Listen for sound of air releasing from exhaust port on underside of valve. After an initial release of air, there should be no more leakage.

Replace defective relay emergency valve (see paragraph 4-62) or full function valve (see paragraph 4-66).

Step 3. Check for properly adjusted brakes (see paragraph 4-59).

Perform minor brake adjustment (see paragraph 4-59).

Step 4. If brakes do not adjust properly, remove hub and brakedrum (see paragraph 4-75). Check for weak or broken brakeshoe return springs (see paragraph 4-57).

Replace damaged brakeshoe return springs and any other damaged components (see paragraph 4-57).



Table 4-2. Unit Troubleshooting (Con't).

MALFUNCTION	TEST OR INSPECTION	CORRECTIVE ACTION
8. BRAKES DRAG.		
	Step 1.	If rear wheels are affected, check operation of parking brake lever. Check that lever moves freely up and down. Replace damaged parking brake lever (see paragraph 4-69).
	Step 2.	Check for properly adjusted brakes (see paragraph 4-59). Perform minor brake adjustment (see paragraph 4-59).
	step 3.	If rear wheels are affected, check operation of airbrake chambers. Check for leaks in air lines to and from airbrake chambers. Check for leaks or damage to airbrake chambers. Check that spring in each airbrake chamber is fully released. Cage brakes (see paragraph 456). Replace damaged airbrake chambers (see paragraph 4-61). If brakes cannot be caged, replace damaged airbrake chambers (see paragraph 4-61).
	Step 4.	Remove hub and brakedrum (see paragraph 4-75). Check for weak or broken brakeshoe return springs (see paragraph 4-57). Replace weak or broken brakeshoe return springs (see paragraph 4-57). Replace any other damaged components (see paragraph 4-57).
	Step 5.	Check for loose wheel bearings (see paragraph 4-75). Adjust wheel bearings (see paragraph 4-75).
	Step 6.	Check for damage to wedge assembly (see paragraph 4-60). Replace damaged wedge assembly (see paragraph 4-60).
9. BRAKES GRAB.		



- DO NOT disconnect air lines and fittings while dolly set airbrake system is pressurized. Intervehicular air lines must be disconnected and air reservoirs drained before air lines and fittings are disconnected. A line or fitting disconnected under pressure may explode with great force and cause serious injury to personnel.
- Wear eye protection when working with compressed air to avoid serious eye injury.

## NOTE

Refer to airbrake system schematics for assistance (see paragraph 4-74).

- Step 1. Perform airbrake system leakage check (see paragraph 4-23).  
Replace damaged air lines (see paragraph 4-72 or 4-73).

Table 4-2. Unit Troubleshooting (Con't).

MALFUNCTION	TEST OR INSPECTION	CORRECTIVE ACTION
	Step 2.	Check for damage to airbrake chambers. Replace damaged airbrake chambers (see paragraph 4-61).
	Step 3.	Check for properly adjusted brakes (see paragraph 4-59). Perform minor brake adjustment (see paragraph 4-59).
	Step 4.	Check wheel bearing adjustment (see paragraph 4-75). Adjust wheel bearings (see paragraph 4-75).
	Step 5.	Remove hub and brakedrum (see paragraph 4-75). Inspect brakedrum for damage. Inspect wheel bearings for wear. Inspect brakeshoes for damage, wear, or grease-soaked linings (see paragraph 4-57). Replace damaged brakedrum and worn wheel bearings (see paragraph 4-75). If grease is found on brakeshoe linings, inspect wheel seal. Replace damaged wheel seal (see paragraph 4-75). Replace damaged, worn, or grease-soaked brakeshoes (see paragraph 4-57).
	Step 6.	Notify Direct Support Maintenance to check brakedrums for out-of-round.
10. PARKING BRAKES (REAR DOLLY) DO NOT HOLD.		
	Step 1.	Check operation of parking brake lever. Check that lever moves freely up and down. Replace damaged parking brake lever (see paragraph 4-69).
	Step 2.	Check for damage to full function valve. Replace damaged full function valve (see paragraph 4-66).
	Step 3.	Check for damage to airbrake chamber. Replace damaged airbrake chamber (see paragraph 4-61).
	Step 4.	Check for properly adjusted brakes (see paragraph 4-59). Perform minor brake adjustment (see paragraph 4-59).

Table 4-2. Unit Troubleshooting (Con't).

MALFUNCTION	TEST OR INSPECTION	CORRECTIVE ACTION
-------------	--------------------	-------------------

## 11. PARKING BRAKES (REAR DOLLY) DO NOT RELEASE.



- DO NOT disconnect air lines and fittings while dolly set airbrake system is pressurized. Intervehicular air lines must be disconnected and air reservoirs drained before air lines and fittings are disconnected. A line or fitting disconnected under pressure may explode with great force and cause serious injury to personnel.
- Wear eye protection when working with compressed air to avoid serious eye injury.

## NOTE

Refer to airbrake system schematics for assistance (see paragraph 4-74).

Step 1. Check operation of parking brake lever. Check that lever moves freely up and down.

Replace damaged parking brake lever (see paragraph 4-69).

Step 2. Check parking brake air supply to air reservoir and air lines between parking brake lever and rear chamber of airbrake chambers at wheels.

Replace leaking or damaged air lines (see paragraph 4-73).

Step 3. Check that spring in each airbrake chamber is fully released. Cage brakes (see paragraph 4-56).

If brakes cannot be caged, replace damaged airbrake chambers (see paragraph 4-61).

## 12. UNEVEN BRAKESHOE LINING WEAR.

Step 1. Remove hub and brakedrum (see paragraph 4-75). Check for wear or damage to brakeshoe return springs (see paragraph 4-57).

Replace weak or damaged brakeshoe return springs (see paragraph 4-57).

Step 2. Check for damage to wedge assembly (see paragraph 4-60).

Replace damaged wedge assembly (see paragraph 4-60).

Step 3. If malfunction persists, replace spider assembly with wedge brake components (see paragraph 4-60).

Step 4. Notify Direct Support Maintenance to check brakedrums for out-of-round.

Table 4-2. Unit Troubleshooting (Con't).

MALFUNCTION	TEST OR INSPECTION	CORRECTIVE ACTION
-------------	--------------------	-------------------

TIRES

13. UNEVEN OR ABNORMAL WEAR.

- Step 1. Check for bent wheel assembly (see paragraph 4-76).  
 Replace bent wheel assembly (see paragraph 4-76).
- Step 2. Check for looseness and damage to tie-rod ends. Check wheel alignment (see paragraph 4-77).  
 Tighten or replace damaged tie-rod ends (see paragraph 4-77). Aline wheels (see paragraph 4-77).
- Step 3. Check for loose or defective wheel bearings (see paragraph 4-75).  
 Replace damaged wheel bearings (see paragraph 4-75). Perform wheel bearing adjustment (see paragraph 4-75).
- Step 4. Check for loose kingpins and steering link (see paragraphs 4-54 and 4-78).  
 Tighten or replace damaged components (see paragraphs 4-54 and 4-78).
- Step 5. Check steering knuckle assembly for movement where roll pin joins steering knuckle to spindle (see paragraph 4-54).  
 Replace steering knuckle assembly if movement is present (see paragraph 4-54).

HYDRAULIC SYSTEM

14. HYDRAULIC SYSTEM WILL NOT OPERATE.

- Step 1. Inspect engine.  
 Troubleshoot engine (see paragraph 4-32).
- Step 2. Remove access cover from adapter and check hydraulic pump coupling for damage (see paragraph 4-107).  
 Replace damaged hydraulic pump coupling (see paragraph 4-107).
- Step 3. Check for leaking or damaged hydraulic pump.  
 Replace damaged hydraulic pump (see paragraph 4-107).

Table 4-2. Unit Troubleshooting (Con't).

MALFUNCTION	TEST OR INSPECTION	CORRECTIVE ACTION
-------------	--------------------	-------------------

## 15. LIFT CYLINDER(S) WILL NOT OPERATE.

Step 1. Check hydraulic control valve for damage. Check for proper operation of levers (see paragraph 2-21).

Replace damaged hydraulic control valve (see paragraph 4-108).

Step 2. Check for leaking or damaged lift cylinder.

Replace damaged lift cylinder (see paragraph 4-110).

## 16. POSITIONING CYLINDER(S) WILL NOT OPERATE.

Step 1. Check hydraulic control valve for damage. Check for proper operation of lever (see paragraph 2-21).

Replace damaged hydraulic control valve (see paragraph 4-108).

Step 2. Check for leaking or damaged positioning cylinder.

Replace damaged positioning cylinder (see paragraph 4-83).

## 17. LIFT CYLINDER DRIFTS.

Check hydraulic control valve for proper operation of levers (see paragraph 2-21). Ensure that lever(s) return to center position.

Replace damaged hydraulic control valve (see paragraph 4-108).

Replace damaged check valve (see paragraph 4-110).

Table 4-2. Unit Troubleshooting (Con't).

MALFUNCTION

TEST OR INSPECTION

CORRECTIVE ACTION

ENGINE

18. ENGINE WILL NOT TURN OVER WHEN STARTER SWITCH IS SET TO "ST".



- Remove all jewelry such as I.D. tags, rings, bracelets, etc. If jewelry contacts battery terminal, a direct short will result causing instant heating of jewelry which will result in serious injury or death to personnel.
- Battery acid (electrolyte) is extremely dangerous. Always wear protective goggles and rubber gloves when performing battery checks or inspections. Serious injury to personnel will result if battery acid contacts skin or eyes.
- DO NOT perform battery system checks or inspections while smoking or near fire, flames, or sparks. Battery gases may explode, causing serious injury or death to personnel.

NOTE

Refer to engine wiring diagram for assistance (see paragraph 4-135).

Step 1. Inspect for corroded or loose terminal connections at battery, starter, and starter switch, and ground connection at crankcase.

Remove, clean, and tighten all corroded or loose connections (see paragraphs 4-45, 4-130, and 4-131).

Step 2. Check for damaged battery.

Replace damaged battery (see paragraph 4-43).

Step 3. Check for discharged battery (see TM 9-6140-200-14).

Charge discharged battery (see TM 9-6140-200-14).

**CAUTION**

Before performing a continuity test, always disconnect battery negative (-) ground cable and circuit to be tested. Failure to follow this caution may damage multimeter.

Step 4. Test operation of starter switch by disconnecting starter switch connector from engine wiring harness connector (see paragraph 4-131). Perform continuity test at each position of starter switch.

Replace damaged starter switch (see paragraph 4-131).

Table 4-2. Unit Troubleshooting (Con't).

MALFUNCTION	TEST OR INSPECTION	CORRECTIVE ACTION
-------------	--------------------	-------------------

Step 5. Test for continuity through fusible link of engine wiring harness (see paragraph 4-132).  
Replace damaged engine wiring harness (see paragraph 4-132).

Step 6. Inspect starter motor rotation with starter switch set to ST (see paragraph 2-20).  
If starter motor is not turning, replace damaged starter (see paragraph 4-130).

#### 19. BATTERY WILL NOT HOLD CHARGE.



- Remove all Jewelry such as I.D. tags, rings, bracelets, etc. If Jewelry contacts battery terminal, a direct short will result causing instant heating of jewelry which will result in serious injury or death to personnel.
- Battery acid (electrolyte) is extremely dangerous. Always wear protective goggles and rubber gloves when performing battery checks or inspections. Serious injury to personnel will result if battery acid contacts skin or eyes.
- DO NOT perform battery system checks or inspections while smoking or near fire, flames, or sparks. Battery gases may explode, causing serious injury or death to personnel.

#### NOTE

Refer to engine wiring diagram for assistance (see paragraph 4-135).

Step 1. Inspect battery for cracked or damaged case.

Replace damaged battery (see paragraph 4-43).

Step 2. Inspect for corroded or loose terminal connections at battery and starter, and ground connection at crankcase.

Remove, clean, and tighten all corroded or loose connections (see paragraphs 4-45 and 4-130).

Step 3. Inspect engine wiring harness connections at starter switch, regulator, stator assembly leads, and ground connections.

Remove, clean, and tighten all corroded or loose connections (see paragraph 4-132).

Replace damaged regulator (see paragraph 4-129).

Table 4-2. Unit Troubleshooting (Con't).

MALFUNCTION	TEST OR INSPECTION	CORRECTIVE ACTION
-------------	--------------------	-------------------

Step 4. With engine running, test stator assembly (alternator) output by disconnecting engine wiring harness connector from regulator (see paragraph 4-129). Using a multimeter set to DC voltage, measure stator assembly output.

If stator assembly output is within 12 V dc  $\pm$  1 V dc, replace damaged regulator (see paragraph 4-129).

20. BATTERY OVERCHARGES.



- Remove all jewelry such as I.D. tags, rings, bracelets, etc. If jewelry contacts battery terminal, a direct short will result causing instant heating of jewelry which will result in serious injury or death to personnel.
- Battery acid (electrolyte) is extremely dangerous. Always wear protective goggles and rubber gloves when performing battery checks or inspections. Serious injury to personnel will result if battery acid contacts skin or eyes.
- DO NOT perform battery system checks or inspections while smoking or near fire, flames, or sparks. Battery gases may explode, causing serious injury or death to personnel.

NOTE

Refer to engine wiring diagram for assistance (see paragraph 4-135).

With engine running, test stator assembly (alternator) output by disconnecting engine wiring harness connector from regulator (see paragraph 4-129). Using a multimeter set to DC voltage, measure stator assembly output.

If stator assembly output is within 12 V dc  $\pm$  1 V dc, replace damaged regulator (see paragraph 4-129).

If stator assembly output is not 12 V dc  $\pm$  1 V dc, replace damaged stator assembly (see paragraph 4-116).



Table 4-2. Unit Troubleshooting (Con't).

MALFUNCTION	TEST OR INSPECTION	CORRECTIVE ACTION
-------------	--------------------	-------------------

## 21. ENGINE TURNS OVER BUT WILL NOT START



Diesel fuel is combustible. DO NOT smoke or allow an open flame near fuel tank. Shut down engine when adding fuel. Failure to follow this warning will result in serious injury or death to personnel. If you are burned, immediately seek medical attention.

Step 1. Remove cap from fuel tank (see paragraph 4-125). Check for clogged vent in cap.

Clean or replace damaged cap (see paragraph 4-125).

Step 2. Check fuel lines for leaks, clogging, or damage.

Tighten or replace damaged fuel lines (see paragraph 4-122).



If NBC exposure is suspected, ail engine air cleaner air filter media should be handled by personnel wearing protective equipment. Consult your NBC Officer or NBC NCO for appropriate handling or disposal procedures.

Step 3. Check for clogged air cleaner element (see paragraph 4-123).

Clean or replace damaged air cleaner element (see paragraph 4-123).

Step 4. Remove side cover (see paragraph 4-126). Inspect speed control lever and stop lever for free movement and signs of damage.

Clean speed control lever and stop lever, and lubricate with lubricating oil (Item 23, Appendix F) as required.

If levers are frozen or damaged, notify Direct Support Maintenance.

Table 4-2. Unit Troubleshooting (Con't).

MALFUNCTION	TEST OR INSPECTION	CORRECTIVE ACTION
-------------	--------------------	-------------------



Diesel fuel is combustible. DO NOT smoke or allow an open flame near fuel tank. Shut down engine when adding fuel. Failure to follow this warning will result in serious injury or death to personnel. If you are burned, immediately seek medical attention.

- Step 5. Check for clogged fuel filter and vent at tip of filter (see paragraph 4-124).  
Clean or replace damaged fuel filter (see paragraph 4-124).
- Step 6. Check injection pump for correct timing (see paragraph 4-120).  
Adjust injection pump timing (see paragraph 4-120).
- Step 7. Remove and inspect nozzle holder for clogging or damage (see paragraph 4-121).  
Replace damaged nozzle holder (see paragraph 4-121).  
Replace damaged injection pump (see paragraph 4-120).

22. ENGINE WILL NOT START IN COLD WEATHER [BELOW 41<sup>0</sup>F (5<sup>0</sup>C)].

**CAUTION**

Before performing a continuity test, always disconnect battery negative (-) ground cable and circuit to be tested. Failure to follow this caution may damage multimeter.

NOTE

Refer to engine wiring diagram for assistance (see paragraph 4-135).

- Step 1. Remove glow plug from cylinder head (see paragraph 4-133). Use a multimeter to measure resistance between glow plug terminal and housing. Resistance should read 1.0-1.2 ohms.  
Replace damaged glow plug (see paragraph 4-133).
- step 2. Test glow plug circuit by disconnecting engine wiring harness from glow plug cord connector (see paragraph 4-133). Using multimeter set to DC voltage, check for 12 V dc.  
If no voltage is present, replace damaged engine wiring harness (see paragraph 4-132).

Table 4-2. Unit Troubleshooting (Con't).

MALFUNCTION	TEST OR INSPECTION	CORRECTIVE ACTION
-------------	--------------------	-------------------

**23. ENGINE RUNS ROUGH (MISFIRES).**

Step 1. Check for fuel leakage or air in fuel system due to loose injection pipe nuts (see paragraph 4-122).

Tighten nuts at both ends of injection pipe. Replace damaged injection pipe (see paragraph 4-122).

Step 2. Check for clogged or dirty fuel filter (see paragraph 4-124).

Clean or replace damaged fuel filter (see paragraph 4-124).

Step 3. Check for clogged overflow hose (see paragraph 4-122).

Clean or replace damaged overflow hose (see paragraph 4-122).

Step 4. Remove and inspect nozzle holder for clogging or damage (see paragraph 4-121).

Replace damaged nozzle holder (see paragraph 4-121).

Replace damaged injection pump (see paragraph 4-120).

**24. ENGINE DOES NOT DEVELOP FULL POWER.**

Compressed air used for cleaning or drying purposes, or for clearing restrictions, should never exceed 30 psi (207 kPa). Wear protective clothing (goggles/shield, gloves, etc.) and use caution to avoid injury to personnel.

Step 1. Remove oil cooler cover (see paragraph 4-117). Check for clogged oil cooler fins.



Oil cooler fins are fragile. DO NOT use a tool to remove dirt and obstructions or damage will result.

Clear oil cooler fins of dirt or obstructions with compressed air.

Step 2. Remove cylinder cowling and spiral case (see paragraph 4-128). Check for clogged cylinder cowling and dirt or debris around flywheel.

Clear cylinder cowling and area around flywheel of dirt or debris with compressed air.

Table 4-2. Unit Troubleshooting (Con't).

MALFUNCTION	TEST OR INSPECTION	CORRECTIVE ACTION
-------------	--------------------	-------------------

Step 3. Check injection pump for correct timing (see paragraph 4-120).

Adjust injection pump timing (see paragraph 4-120).

Step 4. Remove and inspect nozzle holder for clogging or damage (see paragraph 4-121).

Replace damaged nozzle holder (see paragraph 4-121).

Replace damaged injection pump (see paragraph 4-120).

25. EXCESSIVE BLACK OR DARK GRAY EXHAUST IS OBSERVED.



If NBC exposure is suspected, all engine air cleaner air filter media should be handled by personnel wearing protective equipment. Consult your NBC Officer or NBC NCO for appropriate handling or disposal procedures.

Step 1. Check for clogged air cleaner element (see paragraph 4-123).

Clean or replace damaged air cleaner element (see paragraph 4-123).

Step 2. Check for clogged fuel filter (see paragraph 4-124).

Clean or replace damaged fuel filter (see paragraph 4-124).

26. EXCESSIVE WHITE OR BLUE EXHAUST IS OBSERVED.

Check injection pump for correct timing (see paragraph 4-120).

Adjust injection pump timing (see paragraph 4-120).

## Section VI. ELECTRICAL SYSTEM MAINTENANCE

Paragraph Number	Paragraph Title	Page Number
4-33.	Signal Conditioning Box and Forward Junction Box Replacement .....	4-47
4-34.	Signal Conditioning Box Repair .....	4-49
4-35.	Forward Junction Box Repair .....	4-54
4-36.	Rear Junction Box Replacement .....	4-59
4-37.	Rear Junction Box Repair .....	4-61
4-38.	Marker Clearance Light Maintenance .....	4-68
4-39.	Blackout Stoplight-Taillight Replacement .....	4-70
4-40.	Taillight Maintenance .....	4-72
4-41.	Taillight Assembly Housing Replacement .....	4-74
4-42.	identification Light Maintenance .....	4-75
4-43.	Battery Maintenance .....	4-78
4-44.	Battery Case Replacement .....	4-80
4-45.	Battery Cables Replacement .....	4-81
4-46.	Signal Conditioning Box-to-Foward Junction Box Cable Assembly Replacement . .	4-04
4-47.	Front Doily Marker Clearance Light Cable Assemblies Replacement .....	4-89
4-48.	Rear Dolly Taillight Assembly Cable Assembly Replacement .....	4-95
4-49.	Identification Light Cable Assembly Replacement .....	4-101
4-50.	WiringDiagrams .....	4-108

---

### 4-33. SIGNAL CONDITIONING BOX AND FORWARD JUNCTION BOX REPLACEMENT.

---

*This Task Covers:*

- |            |                 |
|------------|-----------------|
| a. Removal | b. Installation |
|------------|-----------------|
- 

*Initial Setup:*

**Equipment Conditions:**

- Intervehicular cable disconnected from signal conditioning box (see paragraph 2-7).
- Intradolly cable disconnected from forward junction box (see paragraph 2-7).
- Front dolly marker clearance light cable assemblies removed from signal conditioning box (see paragraph 4-47).

**Materials/Parts:**

- Four locknuts

**Personnel Required:** Two

**Tools/Test Equipment:**

- General mechanic's tool kit (item 30, Appendix G)
-

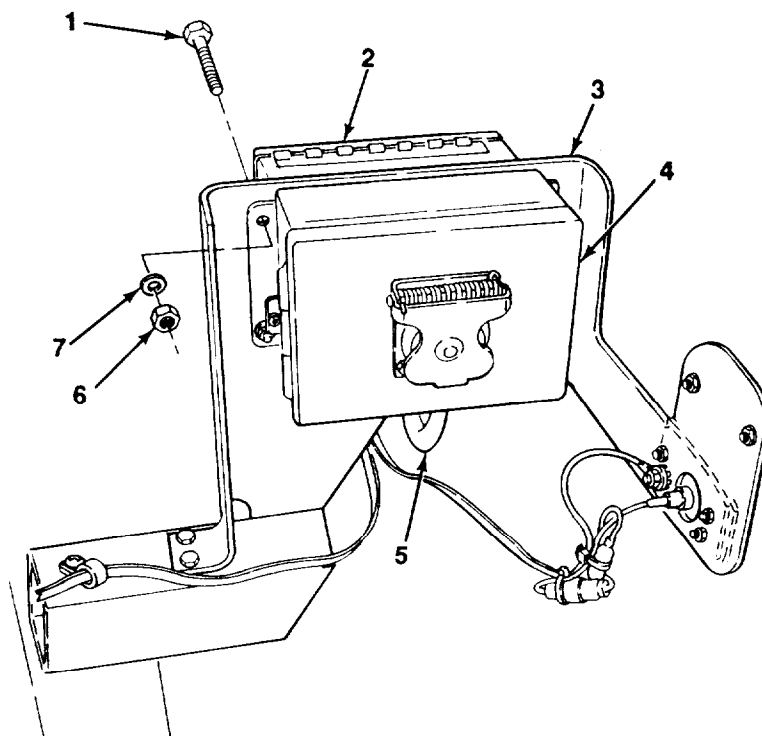
---

## 4-33. SIGNAL CONDITIONING BOX AND FORWARD JUNCTION BOX REPLACEMENT (Con't).

---

### a. REMOVAL

1. Remove four locknuts (6), flatwashers (7), machine bolts (1), signal conditioning box (2), forward junction box (4), and signal conditioning box-to-forward junction box cable assembly (5) from bracket (3). Discard locknuts.
2. Remove signal conditioning box-to-forward junction box cable assembly (5) from signal conditioning box (2) and forward junction box (4) (see paragraph 4-46).



### b. INSTALLATION

1. Install signal conditioning box-to-forward junction box cable assembly (5) on signal conditioning box (2) and forward junction box (4) (see paragraph 4-46).
2. Install signal conditioning box (2), forward junction box (4), and signal conditioning box-to-forward junction box cable assembly (5) on bracket (3) with four machine bolts (1), flatwashers (7), and new locknuts (6).

#### Follow-on Tasks:

- install front dolly marker clearance light cable assemblies on signal conditioning box (see paragraph 4-47).
- Connect intradolly cable to forward junction box (see paragraph 2-11).
- Connect intervehicular cable to signal conditioning box (see paragraph 2-11).
- Check operation of lights.

---

#### 4-34. SIGNAL CONDITIONING BOX REPAIR.

---

*This Task Covers:*

a. Disassembly

b. Assembly

---

*Initial Setup:*

**Equipment Conditions:**

- Signal conditioning box and forward junction box removed (see paragraph 4-33).

**Materials/Parts:**

- Marker tags (Item 28, Appendix F)
- Six lockwashers

**Tools/Test Equipment:**

- General mechanic's tool kit (Item 30, Appendix G)
- 

#### NOTE

- All wires should be tagged before removal. Refer to paragraph 4-18 for tagging instructions.
- Refer to electrical wiring diagrams for assistance (see paragraph 4-50).

#### **a. DISASSEMBLY**

#### NOTE

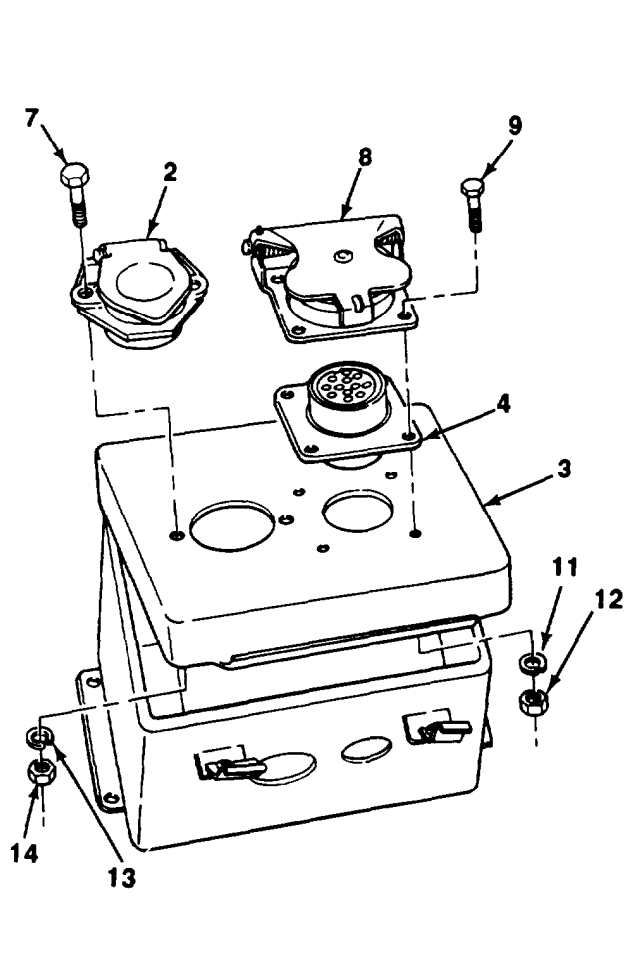
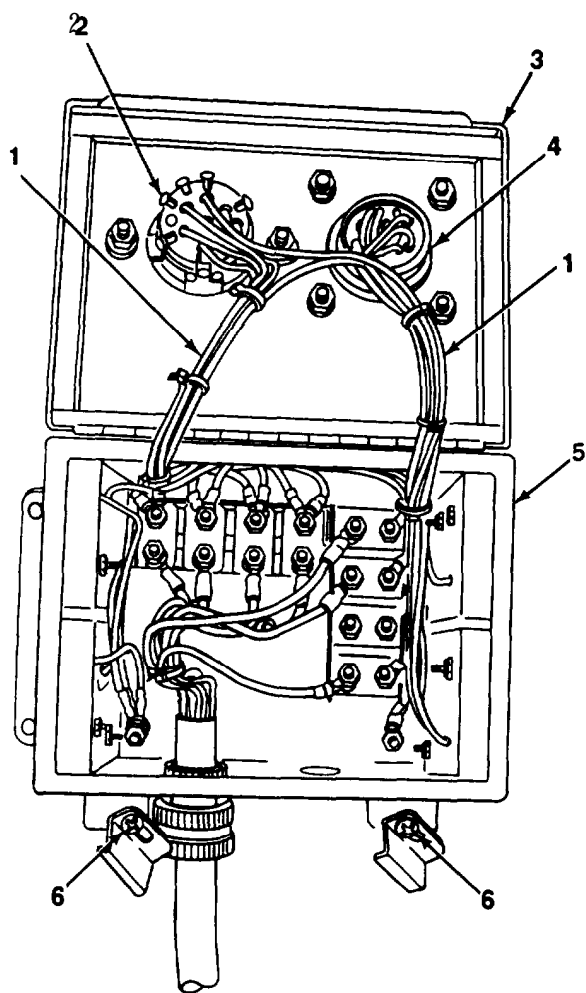
- Perform steps 1 through 3, to remove 24-volt receptacle connector.
- Perform steps 1, 2, and 4, to remove 12-volt receptacle connector.
- Perform steps 1 and 5 through 8, to remove circuit breakers and circuit breaker mounting bracket.
- Perform steps 1, 9, and 10, to remove voltage reducer.

---

**4-34. SIGNAL CONDITIONING BOX REPAIR (Con't).**

---

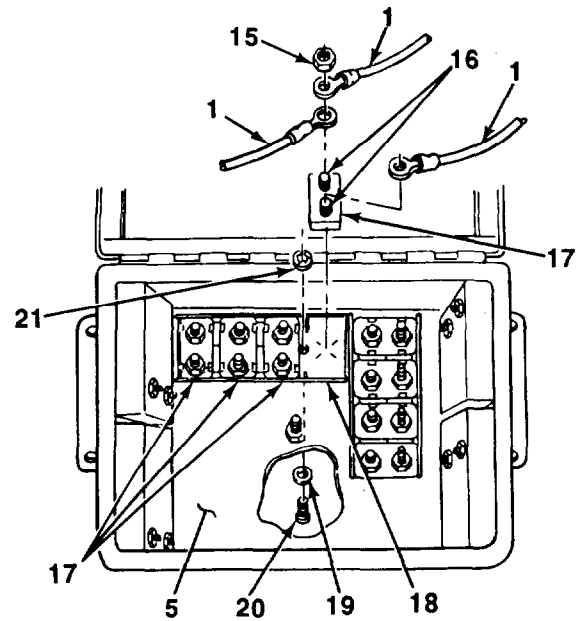
1. Loosen two screws (6) and open cover (3) of signal conditioning box (5).
2. Disconnect wires (1) from 12-volt receptacle connector (2) and wires (1) from 24-volt receptacle connector (4) (see paragraph 4-26).
3. Remove four nuts (12), lockwashers (11), capscrews (9) receptacle cover (8), and 24-volt receptacle connector (4) from cover (3). Discard lockwashers.
4. Remove two nuts (14), lockwashers (13) capscrews (7), and 12-volt receptacle connector (2) from cover (3). Discard lockwashers.



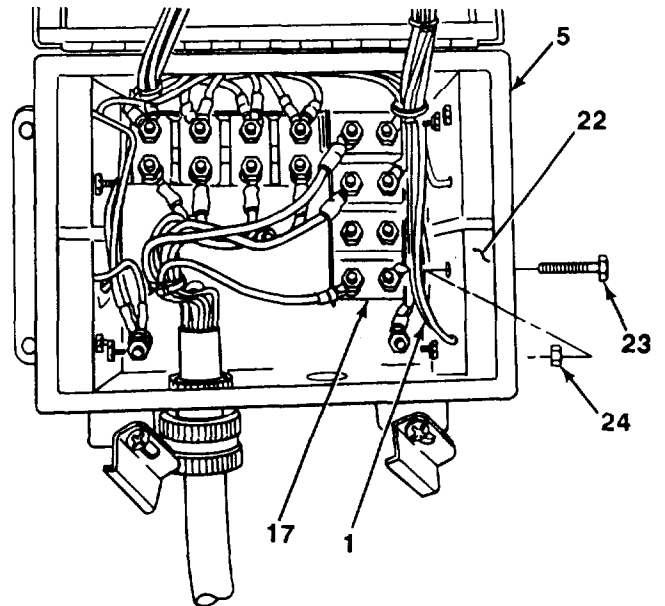


**4-34. SIGNAL CONDITIONING BOX REPAIR (Con't).**

5. Remove two nuts (15) and wires (1) from terminals (16) of circuit breaker (17).
6. Remove circuit breaker (17) from bracket (18).
7. If replacing circuit breaker mounting bracket (18), repeat steps 5 and 6 to remove three remaining circuit breakers (17).
8. If circuit breaker mounting bracket (18) is damaged, remove two panhead screws (20), flatwashers (19), clipnuts (21), and bracket from signal conditioning box (5).



9. Trace two wires (1) of voltage reducer (22) to their points of attachment at either circuit breaker (17) or 12-volt or 24-volt receptacle connector (2 or 4). Disconnect two wires (1).
10. Remove three nuts (24), screws (23), and voltage reducer (22) from signal conditioning box (5).

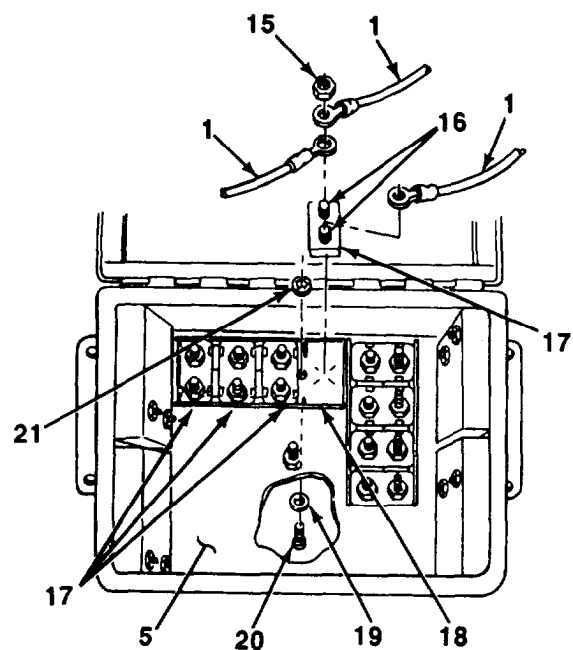
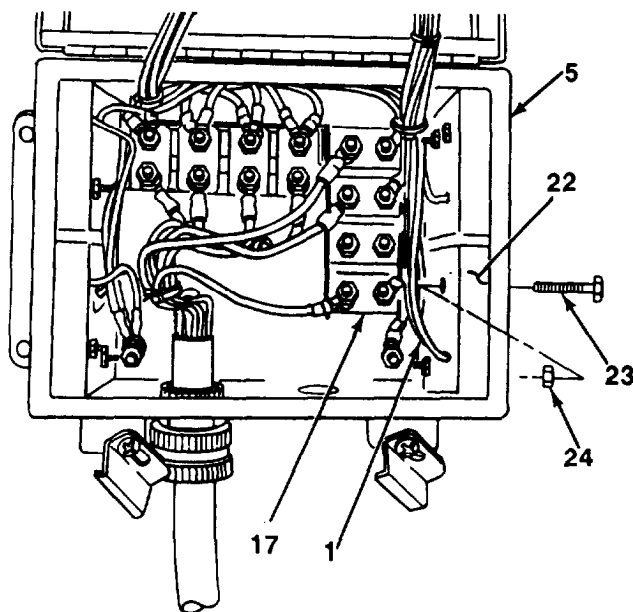


4-34. SIGNAL CONDITIONING BOX REPAIR (Con?).

**b. ASSEMBLY**

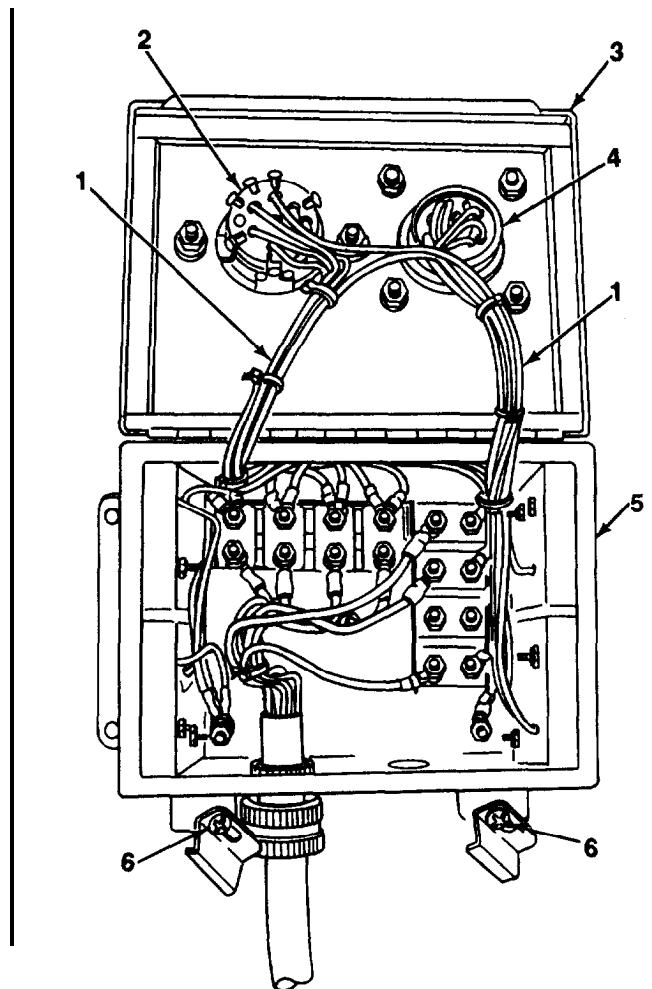
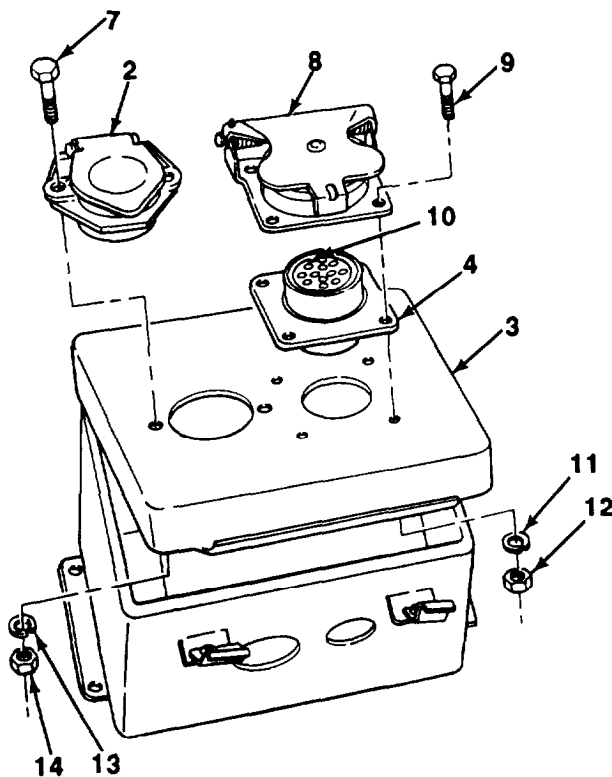
NOTE

- Perform steps 1, 2, and 11, to Install voltage reducer.
  - Perform steps 3 through 6 and 11, to install circuit breakers and circuit breaker mounting bracket.
  - Perform steps 7, 10, and 11, to Install 12-volt receptacle connector.
  - Perform steps 6 through 11, to Install 24-volt receptacle connector.
1. Install voltage reducer (22) on signal conditioning box (5) with three screws (23) and nuts (24).
  2. Connect two wires (1) of voltage reducer (22) to their points of attachment at either circuit breaker (17) or 12-volt or 24volt receptacle connector (2 or 4).
  3. If circuit breaker mounting bracket (18) was removed, install bracket on signal conditioning box (5) with two clipnuts (21), flatwashers (19), and panhead screws (29).
  4. install circuit breaker (17) on bracket (18).
  5. Install wires (1) on terminals (16) of circuit breaker (17) with two nuts (15).
  6. Repeat steps 4 and 5 as required to install three remaining circuit breakers (17).



#### 4-34. SIGNAL CONDITIONING BOX REPAIR (Con't).

7. Install 12-volt receptacle connector (2) on cover (3) with two capscrews (7), new lockwashers (13), and nuts (14).
8. Position 24-volt receptacle connector (4) on cover (3) with alignment key (10) at 12 o'clock position. Position receptacle cover (8) on cover with hinged side facing 12 o'clock position.
9. Install four capscrews (9) new lockwashers (11), and nuts (12).
10. Connect wires (1) to 12-volt receptacle connector (2) and wires (1) to 24-volt receptacle connector (4) (see paragraph 4-26).
11. Close cover (3) and tighten two screws (6).



#### Follow-on Tasks:

- Install signal conditioning box and forward junction box (see paragraph 4-33).
- Check operation of lights.

---

## 4-35. FORWARD JUNCTION BOX REPAIR.

---

*This Task Covers:*

- a. Disassembly
  - b. Cleaning and Inspection
  - c. Assembly
- 

*Initial Setup:*

**Equipment Conditions:**

- Signal conditioning box and forward junction box removed (see paragraph 4-33).
- Signal conditioning box-to-forward junction box cable assembly removed (see paragraph 4-46).

**Tools/Test Equipment:**

- General mechanic's tool kit (Item 30, Appendix G)

**Materials/Parts:**

- Rags (Item 25, Appendix F)
- Dry cleaning solvent (Item 27, Appendix F)
- Marker tags (Item 28, Appendix F)
- Two external-tooth lockwashers
- Four locknuts
- Four lockwashers

**General Safety Instructions:**

- Dry cleaning solvent is flammable and must not be used near an open flame. Use only in a well-ventilated area.
- 

**NOTE**

- All wires should be tagged before removal. Refer to paragraph 4-18 for tagging Instructions.
- Refer to electrical wiring diagrams for assistance (see paragraph 4-50).

**■. DISASSEMBLY**

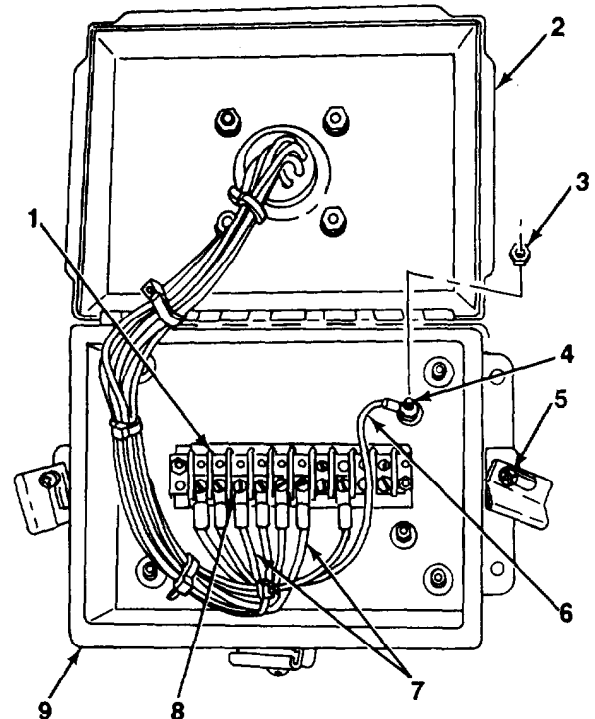
1. Loosen three screws (5) and open cover (2) of forward junction box (9).
2. Remove seven screws (8) and cable assembly wires (7) from positions 1 through 8 and 8 of terminal block (1).

---

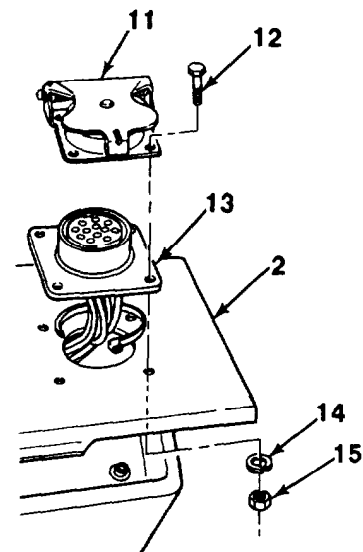
**4-35. FORWARD JUNCTION BOX REPAIR (Con't).**

---

3. Remove nut (3) and green ground wire (6) from top right screw (4).



4. Remove four nuts (15), lockwashers (14), cap-screws (12), and receptacle cover (11) from cover (2). Discard lockwashers.
5. Remove receptacle connector (13) and cable assembly from cover (2).

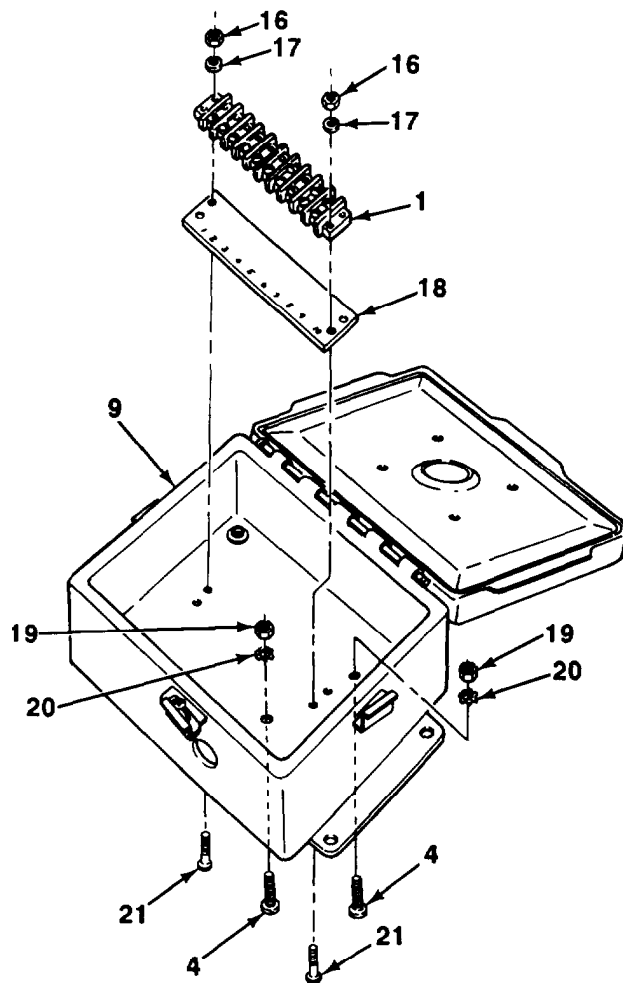


---

#### 4-35. FORWARD JUNCTION BOX REPAIR (Con't).

---

6. Remove two locknuts (16), flatwashers (17), screws (21), terminal block (1), and marker strip (18) from forward junction box (9). Discard locknuts.
7. Remove two locknuts (19), external-tooth lockwashers (20), and screws (4) from forward junction box (9). Discard locknuts and external-tooth lockwashers.



---

**4-35. FORWARD JUNCTION BOX REPAIR (Con't).**


---

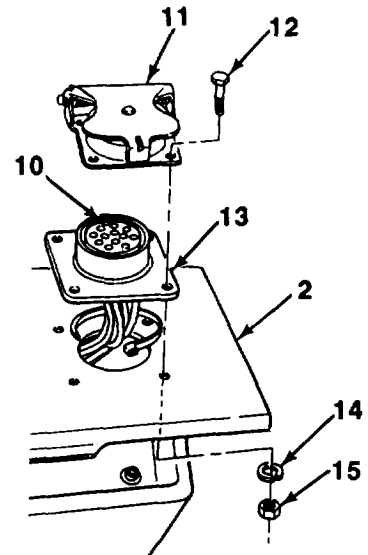
**b. CLEANING AND INSPECTION**


Dry cleaning solvent, P-D-680, is toxic and flammable. Always wear protective goggles and gloves, and use only in a well-ventilated area. Avoid contact with skin, eyes, and clothes, and DO NOT breathe vapors. DO NOT use near open flame or excessive heat. The solvent's flash point is 100°F-138°F (38°C-59°C). If you become dizzy while using cleaning solvent, immediately get fresh air and medical help. If solvent contacts eyes, immediately wash your eyes and seek medical attention.

1. Clean all metal parts with dry cleaning solvent and dry with a clean rag.
2. Clean all other components with a clean rag.
3. Inspect forward junction box and receptacle cover for damage. Replace damaged parts.
4. Inspect receptacle connector and cable assembly for loose or broken wires and terminal lugs, and damaged connector inserts and pins. Replace damaged parts (see paragraph 4-26).

**c. ASSEMBLY**

1. Install two screws (4), new external-tooth lockwashers (20), and new locknuts (19) on forward junction box (9).
2. Install marker strip (18) and terminal block (1) on forward junction box (9) with two screws (21), flatwashers (17) and new locknuts (16).
3. Position receptacle connector (13) and cable assembly on cover (2) with alignment key (10) at 12 o'clock position. Position receptacle cover (11) on cover with hinged side facing 12 o'clock position.
4. Install four capscrews (12), new lockwashers (14) and nuts (15).

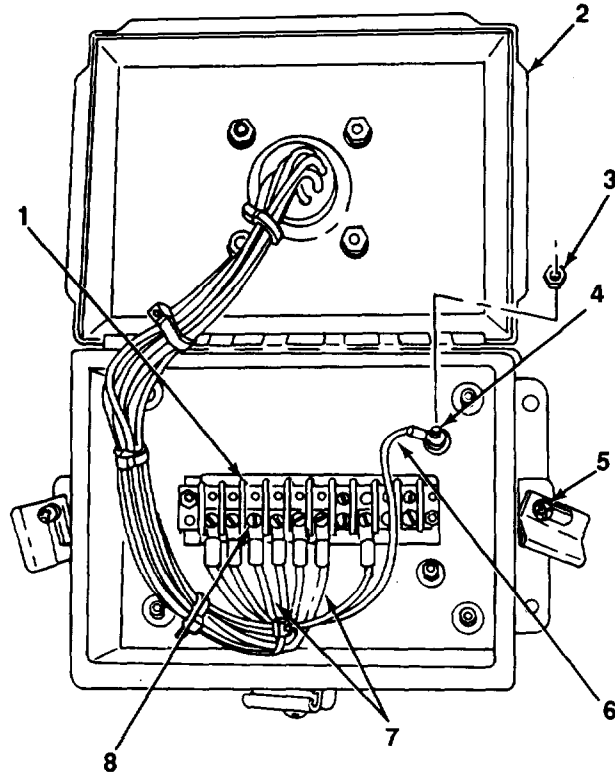


---

**4-35. FORWARD JUNCTION BOX REPAIR (Con't).**

---

5. Install green ground wire (6) on upper right screw (4) with nut (3).
6. Install cable assembly wires (7) on positions 1 through 6 and 8 of terminal block (1) with seven screws (8).
7. Close cover (2) and tighten three screws (5).



**Follow-on Tasks:**

- Install signal conditioning box-to-forward junction box cable assembly (see paragraph 446).
- Install signal conditioning box and forward junction box (see paragraph 4-33).
- Check operation of lights.



---

**4-36. REAR JUNCTION BOX REPLACEMENT.**

---

*This Task Covers:*

a. Removal

b. Installation

---

*Initial Setup:*

**Equipment Conditions:**

- Intradolly cable disconnected from rear junction box (see paragraph 2-7).
- Identification light cable assembly removed from rear junction box (see paragraph 4-49).
- Rear dolly taillight assembly cable assemblies removed from rear junction box (see paragraph 4-48).

**Materials/Parts:**

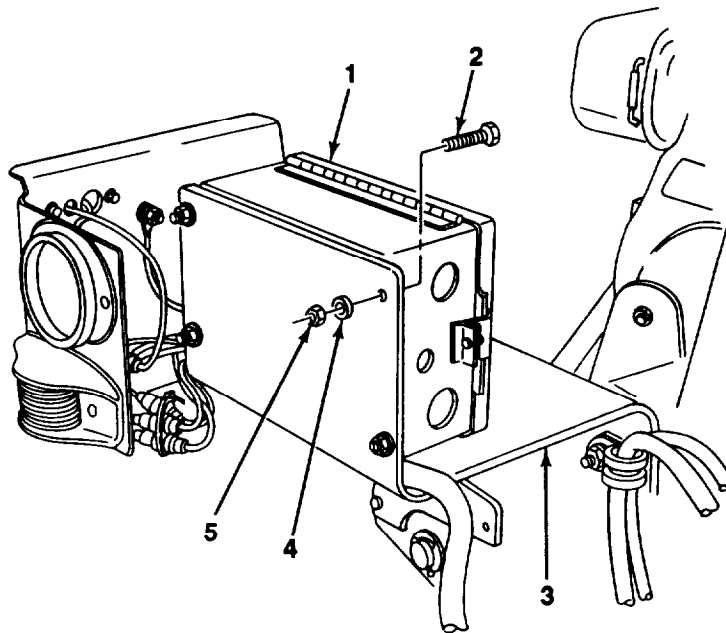
- Four locknuts

**Tools/Test Equipment:**

- General mechanic's tool kit (Item 30, Appendix G)
- 

**a. REMOVAL**

Remove four locknuts (5) flatwashers (4) bolts (2) and rear junction box (1) from bracket (3). Discard locknuts.



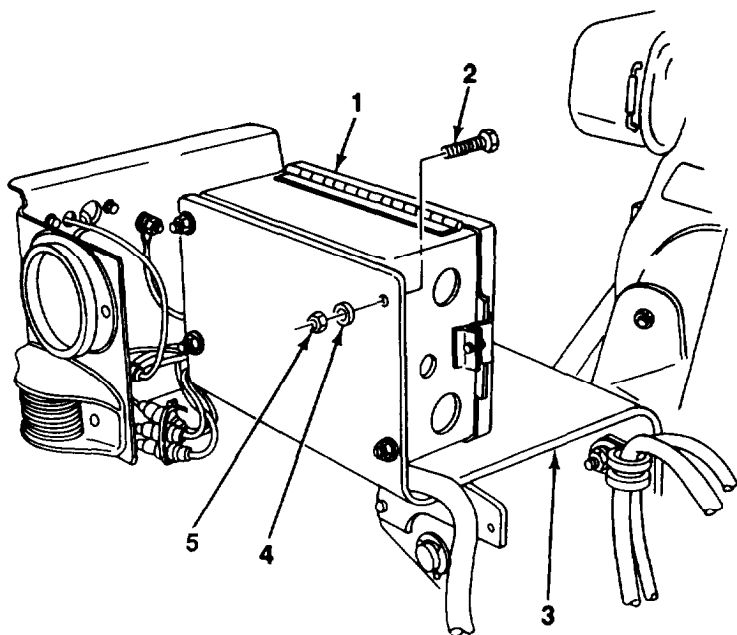
---

4-36. REAR JUNCTION BOX REPLACEMENT (Con?).

---

**b. INSTALLATION**

Install rear junction box (1) on bracket (3) with four bolts (2) flatwashers (4) and new locknuts (5).



Follow-on Tasks:

- Install rear dolly taillight assembly cable assemblies on rear junction box (see paragraph 4-49).
- Install identification light cable assembly on rear junction box (see paragraph 4-49).
- Connect intradolly cable to rear junction box (see paragraph 2-11).
- Check operation of lights.

---

**4-37. REAR JUNCTION BOX REPAIR.**

---

*This Task Covers:*

- |                            |             |
|----------------------------|-------------|
| a. Disassembly             | c. Assembly |
| b. Cleaning and Inspection |             |
- 

*Initial Setup:*

**Equipment Conditions:**

- Rear junction box removed (see paragraph 4-36).

**Tools/Test Equipment:**

- General mechanic's tool kit (Item 30, Appendix G)

**General Safety Instructions:**

- Dry cleaning solvent is flammable and must not be used near an open flame. Use only in a well-ventilated area.

**Materials/Parts:**

- Rags (Item 25, Appendix F)
- Dry cleaning solvent (Item 27, Appendix F)
- Marker tags (Item 28, Appendix F)
- Two external-tooth lockwashers
- Four locknuts
- Four lockwashers

---

**NOTE**

- All wires should be tagged before removal. Refer to paragraph 4-16 for tagging Instructions.
- Refer to electrical wiring diagrams for assistance (see paragraph 4-50).

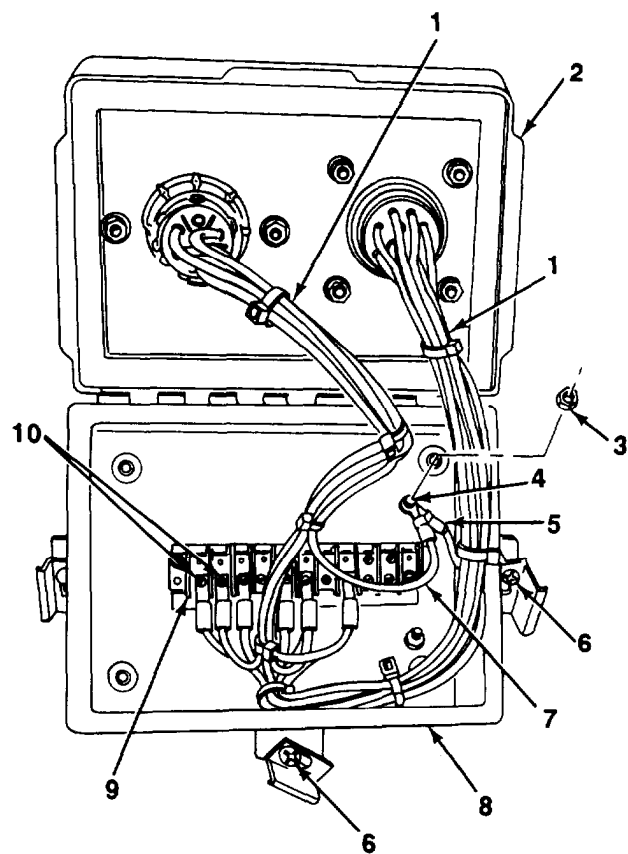
4-37. REAR JUNCTION BOX REPAIR (Con't).

**a. DISASSEMBLY**

NOTE

- Perform steps 1 through 5, to remove 24-volt receptacle connector and cable assembly.
- Perform steps 1 through 3 and 6, to remove 12-volt receptacle connector and cable assembly.

1. Loosen three screws (6) and open cover (2) of rear junction box (8).
2. Remove seven screws (10) and cable assembly wires (1) from positions 1 through 6 and 8 of terminal block (9).
3. Remove nut (3), white ground wire (7), and green ground wire (5) from upper right screw (4).

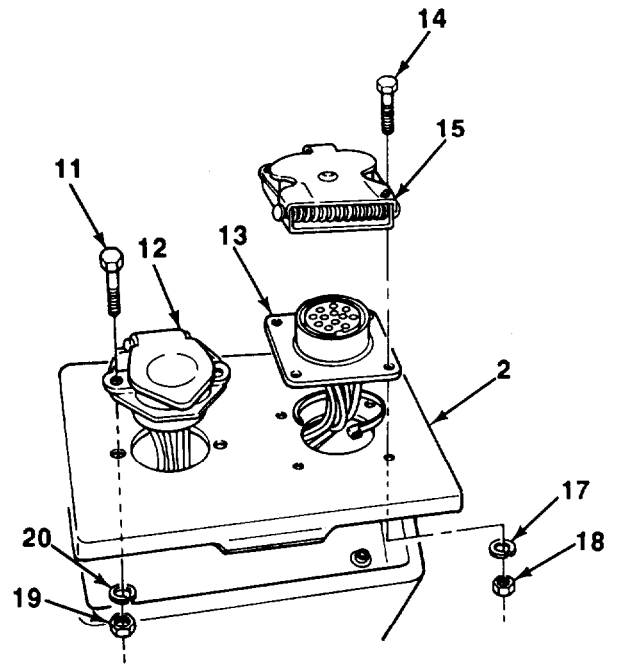


---

**4-37. REAR JUNCTION BOX REPAIR (Con't).**

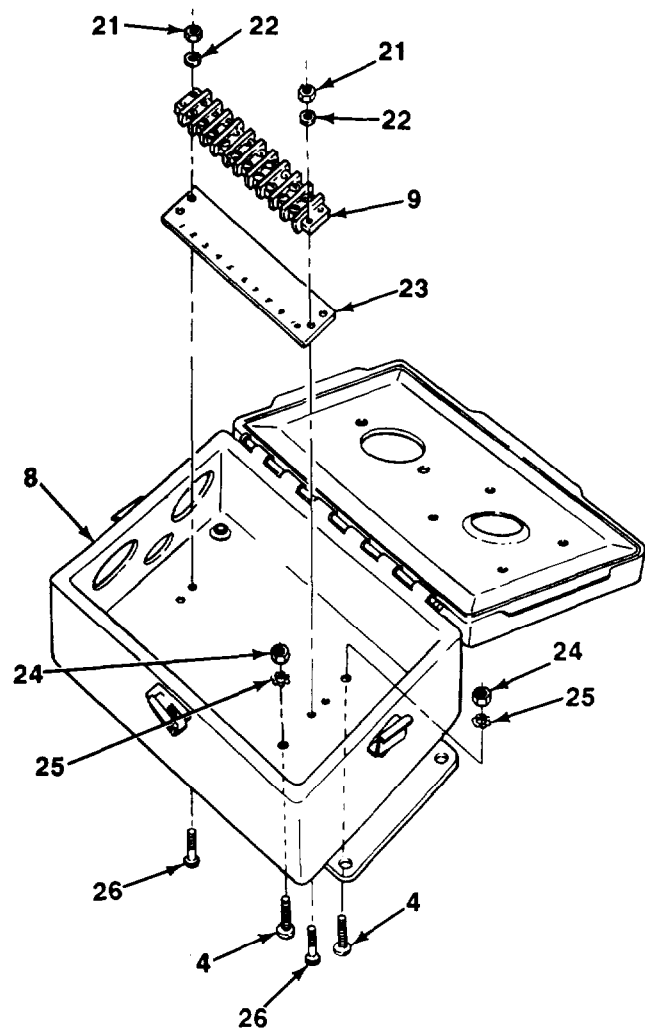
---

4. Remove four nuts (18), lockwashers (17) cap-screws (14), and receptacle cover (15) from cover (2).
5. Remove 24-volt receptacle connector (13) and cable assembly from cover (2).
6. Remove two nuts (19) lockwashers (20), cap-screws (11), and 12-volt receptacle connector (12) and cable assembly from cover (2). Discard lockwashers.



4-37. REAR JUNCTION BOX REPAIR (Con't).

7. Remove two locknuts (21), flatwashers (22), screws (26), terminal block (9), and marker strip (23) from rear junction box (8). Discard locknuts.
8. Remove two locknuts (24), external-tooth lockwashers (25), and screws (4) from rear junction box (8). Discard locknuts and external-tooth lockwashers,



---

**4-37. REAR JUNCTION BOX REPAIR (Con't).**


---

**b. CLEANING AND INSPECTION**


Dry cleaning solvent, P-D-680, is toxic and flammable. Always wear protective goggles and gloves, and use only in a well-ventilated area. Avoid contact with skin, eyes, and clothes, and DO NOT breathe vapors. DO NOT use near open flame or excessive heat. The solvent's flash point is 100°F-138°F (38°C-59°C). If you become dizzy while using cleaning solvent, immediately get fresh air and medical help. If solvent contacts eyes, immediately wash your eyes and seek medical attention.

1. Clean all metal parts with dry cleaning solvent and dry with a clean rag.
2. Clean all other components with a clean rag.
3. Inspect rear junction box, receptacle cover, and cord connector components for damage. Replace damaged parts.
4. Inspect 12-volt and 24-volt receptacle connectors and cable assemblies for loose or broken wires, end connections, and damaged connector inserts and pins. Replace damaged parts (see paragraph 4-26).

**c. ASSEMBLY**
**NOTE**

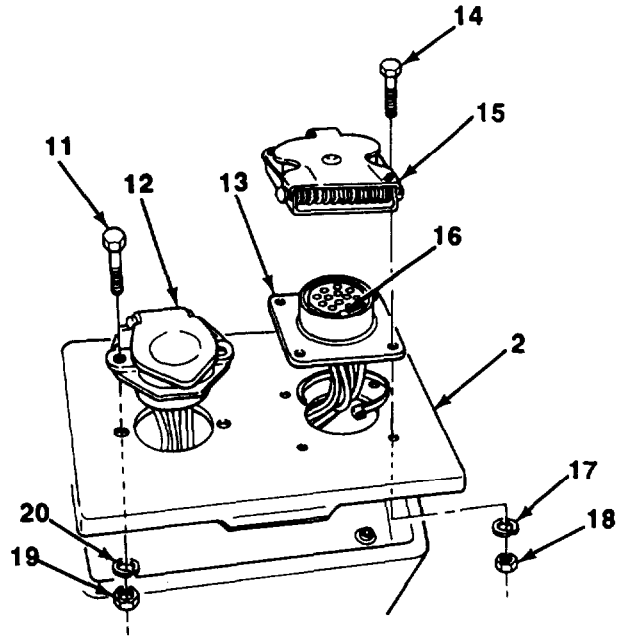
- Perform steps 4 through 8, to Install 24-volt receptacle connector and cable assembly.
  - Perform steps 3 and 6 through 8, to Install 12-volt receptacle connector and cable assembly.
1. Install two screws (4) on rear junction box (8) with new external-tooth lockwashers (25) and new locknuts (24).
  2. Install marker strip (23) and terminal block (9) on rear junction box (8) with two screws (26), flatwashers (22), and new locknuts (21).

---

4-37. REAR JUNCTION BOX REPAIR (Con't).

---

3. Install 12-volt receptacle connector (12) and cable assembly on cover (2) with two capscrews (11), new lockwashers (29), and nuts (19).
4. Position 24-volt receptacle connector (13) and cable assembly on cover (2) with alignment key (16) facing 6 o'clock position. Position receptacle cover (15) on cover with hinged side facing 6 o'clock position.
5. Install four capscrews (14) new lockwashers (17), and nuts (18).



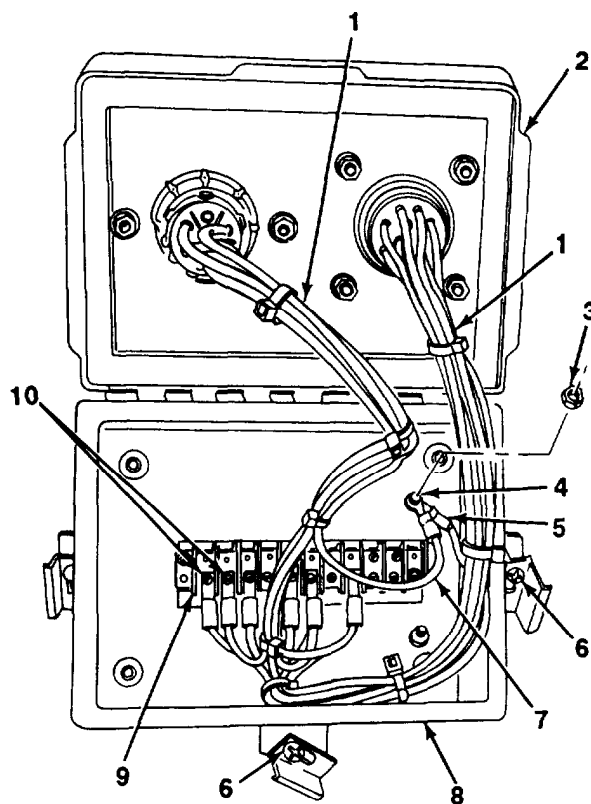


---

**4-37. REAR JUNCTION BOX REPAIR (Con't).**

---

6. Install white ground wire (7) and green ground wire (5) on upper right screw (4) with nut (3).
7. Install cable assembly wires (1) on positions 1 through 6 and 8 of terminal block (9) with seven screws (10).
8. Close cover (2) and tighten three screws (6).

**Follow-on Tasks:**

- Install rear junction box (see paragraph 4-36).
- Check operation of lights.

---

## 4-38. MARKER CLEARANCE LIGHT MAINTENANCE.

---

*This Task Covers:*

- |                     |                 |
|---------------------|-----------------|
| a. Lamp Replacement | C. Installation |
| b. Removal          |                 |
- 

*Initial Setup:*

**Equipment Conditions:**

- Intervehicular cable disconnected from towing vehicle (see paragraph 2-7).

**Materials/Parts:**

- Marker tags (Item 28, Appendix F)
- Tie-down straps
- Four locknuts
- Four lockwashers

**Tools/Test Equipment:**

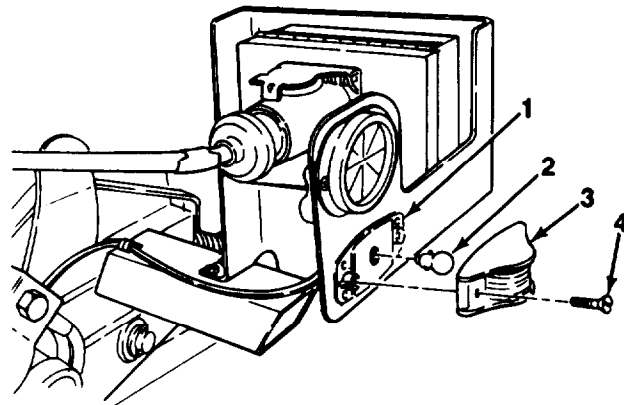
- General mechanic's tool kit (Item 30, Appendix G)
- 

**NOTE**

- Front and rear dolly marker clearance lamps and lights are replaced the same way. Front dolly marker clearance light is shown.
- Front marker clearance lights have amber lenses. Rear marker clearance lights have red lenses.

**a. LAMP REPLACEMENT**

1. Remove two screws (4) and lens housing (3) from body (1).
2. Remove lamp (2) from socket by pressing down on lamp and turning counterclockwise.
3. Install lamp (2) in socket by pressing down on lamp and turning clockwise.
4. Install lens housing (3) on body (1) with two screws (4).



**b. REMOVAL**

**NOTE**

All wires should be tagged before removal. Refer to paragraph 4-18 for tagging Instructions.

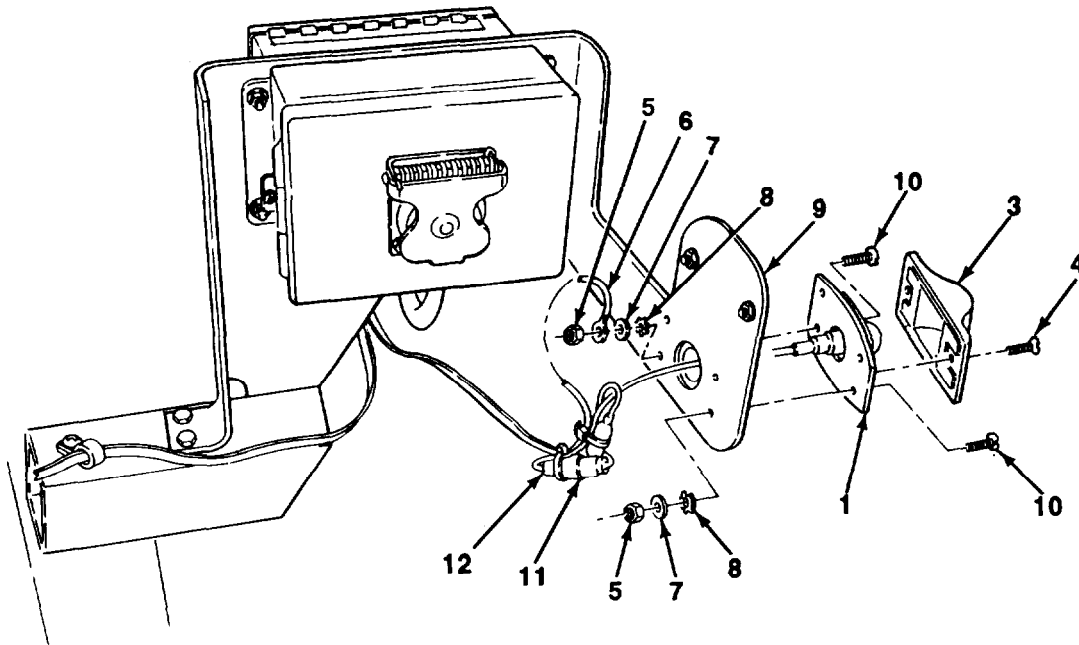
1. Cut tie-down straps from connector plugs (11 and 12). Disconnect marker clearance light connector plug (11) from cable assembly connector plug (12). Discard tie-down straps.

---

**4-38. MARKER CLEARANCE LIGHT MAINTENANCE (Con't).**


---

2. Remove two screws (4) and lens housing (3) from body (1).
3. Remove four locknuts (5), ground wire (6) (front dolly only), four flatwashers (7), lockwashers (8), screws (10), and body (1) from bracket (9). Discard lockwashers and locknuts.
4. If damaged, replace marker clearance light connector plug (11) (see paragraph 4-26).


**c. INSTALLATION**

1. Install body (1) on bracket (9) with four screws (10), new lockwashers (8), flatwashers (7), ground wire (6) (front dolly only), and four new locknuts (5).
2. Install lens housing (3) on body (1) with two screws (4).
3. Connect marker clearance light connector plug (11) to cable assembly connector plug (12). Wrap connector plugs with new tie-down straps.

**Follow-on Tasks:**

- Connect Intervehicular cable to towing vehicle (see paragraph 2-11).
- Check operation of marker clearance light.

---

## 4-39. BLACKOUT STOPLIGHT-TAILLIGHT REPLACEMENT.

---

*This Task Covers:*

- a. Removal b. Installation
- 

*Initial Setup:*

**Equipment Conditions:**

- Intervehicular cable disconnected from towing vehicle (see paragraph 2-7).

**Materials/Parts:**

- Marker tags (Item 28, Appendix F)
- Tie-down straps
- Two locknuts
- Two lockwashers

**Tools/Test Equipment:**

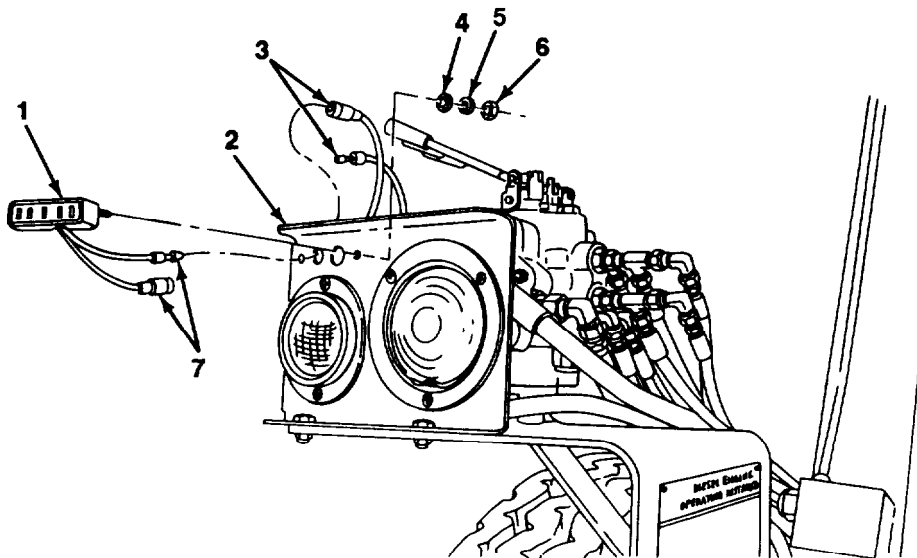
- General mechanic's tool kit (Item 30, Appendix G)
- 

**NOTE**

All wires should be tagged before removal. Refer to paragraph 4-18 for tagging instructions.

**a. REMOVAL**

1. Cut tie-down strap from connector plugs (3 and 7). Disconnect two cable assembly connector plugs (3) from blackout stoplight-taillight connector plugs (7). Discard tie-down strap.
2. Remove two locknuts (6) flatwashers (5), lockwashers (4) and blackout stoplight-taillight (1) from taillight assembly housing (2). Discard lockwashers and locknuts.



---

**4-39. BLACKOUT STOPLIGHT-TAILLIGHT REPLACEMENT (Con't).**

---

**b. INSTALLATION**

1. Install blackout stoplight-taillight (1) on taillight assembly housing (2) with two new lockwashers (4) flatwashers (5) and new locknuts (6).
2. Connect two cable assembly connector plugs (3) to blackout stoplight-taillight connector plugs (7). Wrap connector plugs with new tie-down strap.

**Follow-on Tasks:**

- Connect intervehicular cable to towing vehicle (see paragraph 2-11).
- Check operation of blackout stoplight-taillight.

---

## 4-40. TAILLIGHT MAINTENANCE.

---

*This Task Covers:*

- a. Lamp Replacement
- b. Removal
- c. Installation

---

*Initial Setup:*

**Equipment Conditions:**

- Intervicular cable disconnected from towing vehicle (see paragraph 2-7).

**Tools/Test Equipment:**

- General mechanic's tool kit (Item 30, Appendix G)

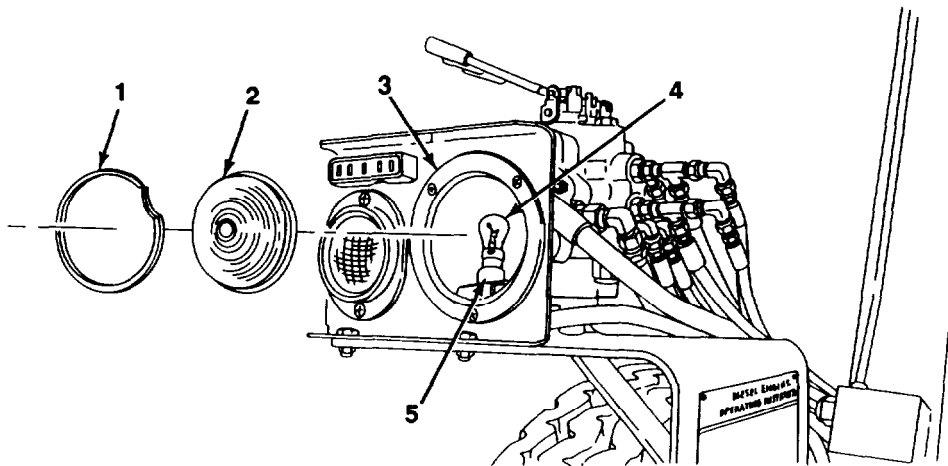
**Materials/Parts:**

- Marker tags (Item 28, Appendix F)
- Tie-down straps
- Three locknuts
- Six lockwashers

---

**a. LAMP REPLACEMENT**

1. Remove snapping (1) and lens (2) from housing (3).
2. Remove lamp (4) from socket (5) by pressing down on lamp and turning counterclockwise.



3. Inspect lens gasket for damage. If damaged, replace lens (2).
4. Install lamp (4) in socket (5) by pressing down on lamp and turning clockwise.
5. Install lens (2) on housing (3) with snapping (1).

---

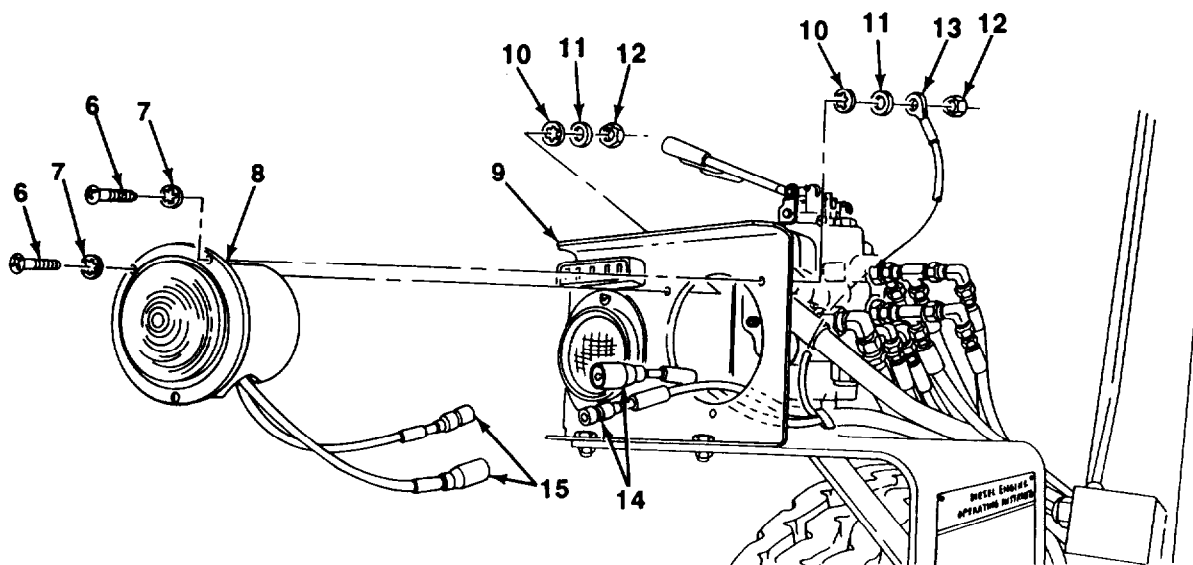
**4-40. TAILLIGHT MAINTENANCE (Con't).**


---

**b. REMOVAL**
**NOTE**

All wires should be tagged before removal. Refer to paragraph 4-18 for tagging Instructions.

1. Cut tie-down strap from connector plugs (14 and 15). Disconnect two taillight connector plugs (15) from cable assembly connector plugs (14). Discard tie-down strap.
2. Remove three locknuts (12), cable assembly ground wire (13), three flatwashers (11), lockwashers (10), panhead screws (6) lo&washers (7) and taillight (6) from taillight assembly housing (9). Discard locknuts and lockwashers.
3. If damaged, replace taillight connector plugs (15) (see paragraph 4-26).


**c. INSTALLATION**

1. Install taillight (8) on taillight assembly housing (9) with three new lockwashers (7) panhead screws (6) new lockwashers (10), flatwashers (11), cable assembly ground wire (13) and three new locknuts (12).
2. Connect two taillight connector plugs (15) to cable assembly connector plugs (14). Wrap connector plugs with new tie-down strap.

**Follow-on Tasks:**

- Connect intervehicular cable to towing vehicle (see paragraph 2-11).
- Check operation of taillight.

---

## 4-41. TAILLIGHT ASSEMBLY HOUSING REPLACEMENT.

---

*This Task Covers:*

- a. Removal b. Installation
- 

*Initial Setup:*

**Equipment Conditions:**

- Marker clearance light removed (see paragraph 4-38).
- Reflectors removed (see paragraph 4-104).
- Blackout stoplight-taillight removed (see paragraph 4-39).
- Taillight removed (see paragraph 4-40).

**Materials/Parts:**

- Two locknuts

**Tools/Test Equipment:**

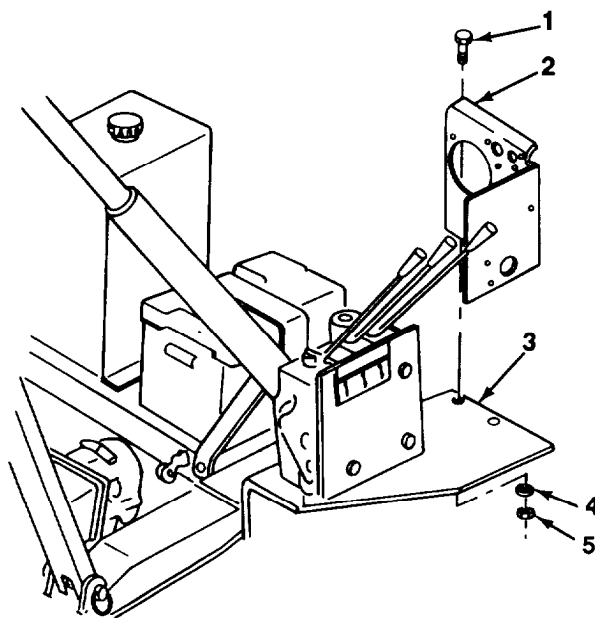
- General mechanic's tool kit (Item 30, Appendix G)
- 

**a. REMOVAL**

Remove two locknuts (5), flatwashers (4), machine bolts (1), and housing (2) from bracket (3). Discard locknuts.

**b. INSTALLATION**

Install housing (2) on bracket (3) with two machine bolts (1), flatwashers (4), and new locknuts (5).



**Follow-on Tasks:**

- Install taillight (see paragraph 4-40).
- Install blackout stoplight-taillight (see paragraph 4-39).
- Install reflectors (see paragraph 4-104).
- Install marker clearance light (see paragraph 4-38).



---

**4-42. IDENTIFICATION LIGHT MAINTENANCE.**

---

*This Task Covers:*

- |                     |                 |
|---------------------|-----------------|
| a. Lamp Replacement | c. Installation |
| b. Removal          |                 |
- 

*Initial Setup:*

**Equipment Conditions:**

- Intervehicular cable disconnected from towing vehicle (see paragraph 2-7).

**Tools/Test Equipment:**

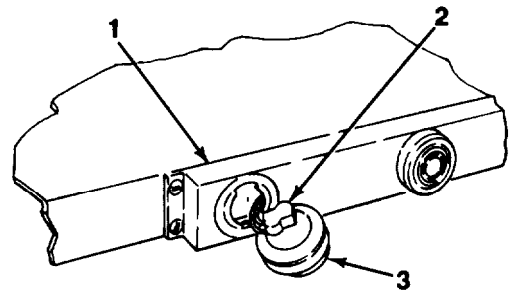
- General mechanic's tool kit (Item 30, Appendix G)

**Materials/Parts:**

- Marker tags (Item 28, Appendix F)
  - Four locknuts
  - Four lockwashers
- 

**a. LAMP REPLACEMENT**

1. Remove lamp unit (3) from housing (1) by turning lamp unit counterclockwise by hand.
2. Remove lamp unit (3) from harness connector (2).
3. Snap lamp unit (3) onto harness connector (2).
4. Install lamp unit (3) on housing (1) by turning lamp unit clockwise by hand.



---

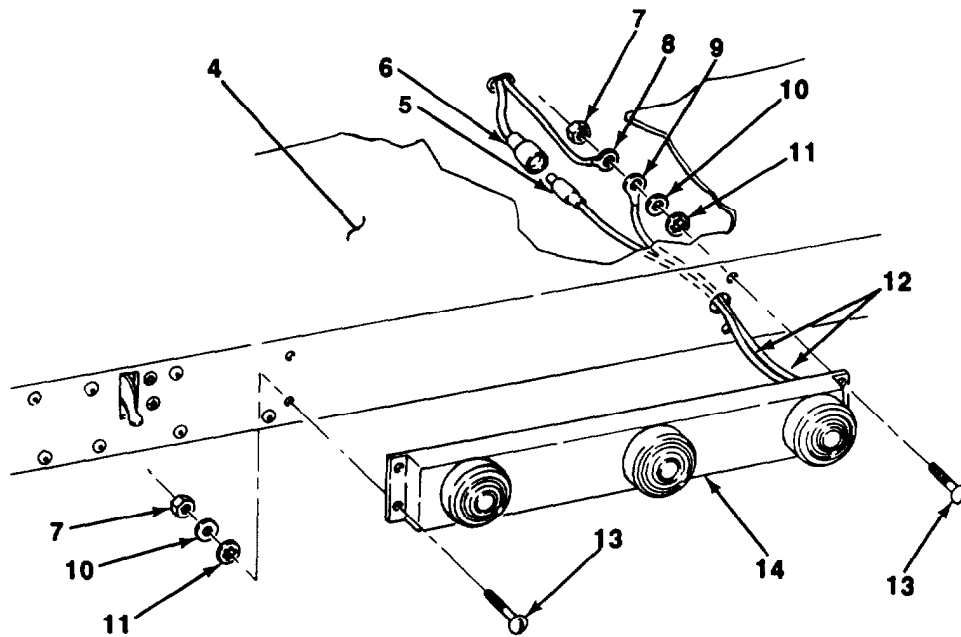
4-42. IDENTIFICATION LIGHT MAINTENANCE (Can't).

---

NOTE

All wires should be tagged before removal. Refer to paragraph 4-18 for tagging instructions.

1. Disconnect identification light connector plug (5) from cable assembly connector plug (6).
2. Remove four locknuts (7), two ground wires (8 and 9), four flatwashers (10), lockwashers (11), panhead screws (13), and identification light (14) from pivoting tray (4). Discard locknuts and lockwashers.
3. If damaged, replace identification light connector plug (5) and ground wire (9) (see paragraph 4-26).



---

**4-42. IDENTIFICATION LIGHT MAINTENANCE (Con't).**

---

**c. INSTALLATION**

1. Position identification light (14) at pivoting tray (4) with two leads (12) through hole in pivoting tray.
2. Install identification light (14) on pivoting tray (4) with four panhead screws (13) new lockwashers (11) fiatwashers (10), two ground wires (8 and 9), and four new locknuts (7).
3. Connect identification light connector plug (5) to cable assembly connector plug (6).

**Follow-on Tasks:**

- Connect intervehicular cable to towing vehicle (see paragraph 2-11).
- Check operation of identification light.

---

## 4-43. BATTERY MAINTENANCE.

---

*This Task Covers:*

- |            |                 |
|------------|-----------------|
| a. Removal | c. Service      |
| b. Test    | d. Installation |
- 

*Initial Setup:*

**Equipment Conditions:**

- Engine starter switch set to OFF position (see paragraph 2-20).
- Battery cables disconnected (see paragraph 4-45).

**References:**

- TM 9-6140-200-14

**General Safety instructions:**

- DO NOT perform battery system maintenance while smoking or near fire, flames, or sparks.
- 



- Remove all jewelry such as I.D. tags, rings, bracelets, etc. if jewelry contacts battery terminal, a direct short will result causing instant heating of jewelry which will result in serious injury or death to personnel.
- DO NOT perform battery system checks or inspections while smoking or near fire, flames, or sparks. Battery gases may explode, causing serious injury or death to personnel.
- Sulfuric acid contained in batteries can cause serious burns. If battery corrosion or electrolyte makes contact with skin, eyes, or clothing, take immediate action to stop the corrosive burning effects. Failure to follow these procedures may result in serious injury or death to personnel.
  - a. Eyes. Flush with cold water for no less than 15 minutes and immediately seek medical attention.
  - b. Skin. Flush with large amounts of cold water until all acid is removed. Seek medical attention as required.
  - c. Internal. If corrosion or electrolyte is ingested, drink large amounts of water or milk. Follow with milk of magnesia, beaten egg, or vegetable oil. Immediately seek medical attention.
  - d. Clothing/Equipment. Wash area with large amounts of cold water. Neutralize acid with baking soda or household ammonia.

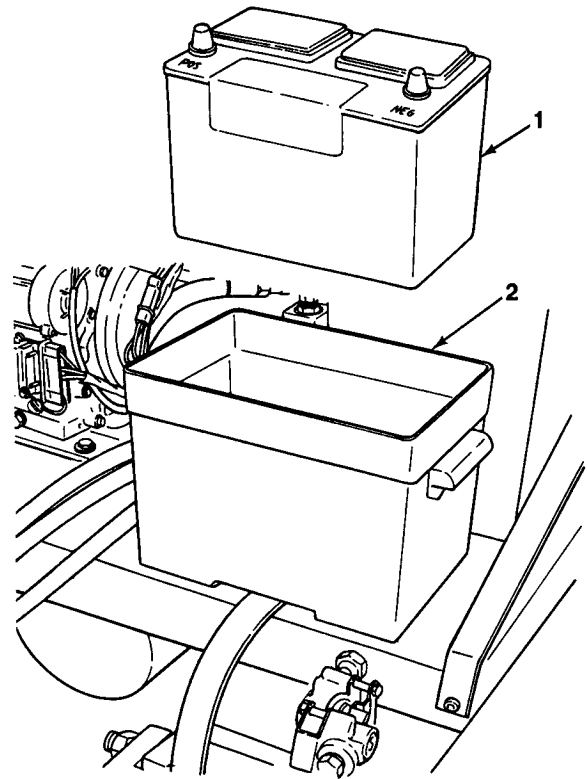
---

**4-43. BATTERY MAINTENANCE (Con't).**

---

**a. REMOVAL**

Remove battery (1) from battery case (2).

**b. TEST**

Test battery (1) in accordance with TM 9-6140-200-14.

**c. SERVICE**

Service battery (1) in accordance with TM 9-6140-200-14.

**d. INSTALLATION**

Install battery (1) inside battery case (2).

**Follow-on Tasks:**

- Connect battery cables (see paragraph 4-45).

## 4-44. BATTERY CASE REPLACEMENT.

*This Task Covers:*

a. Removal

b. Installation

*Initial Setup:*

### Equipment Conditions:

- Battery removed (see paragraph 4-43).

### Tools/Test Equipment:

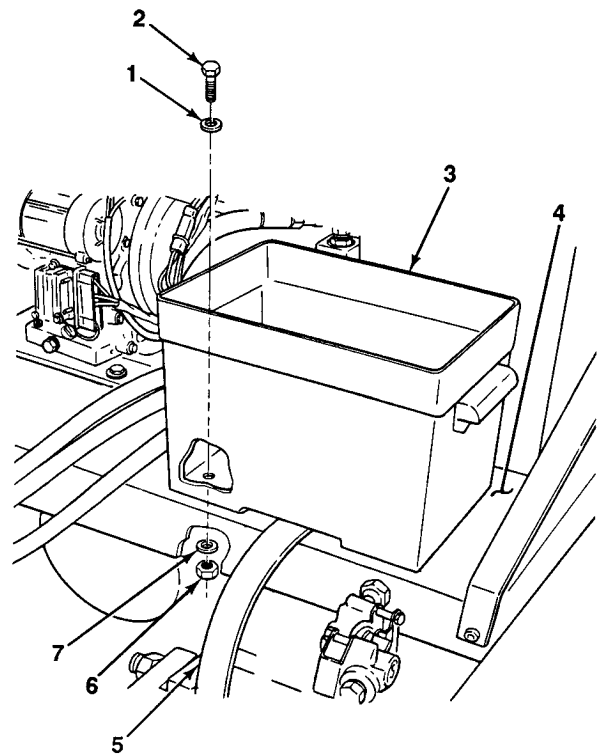
- General mechanic's tool kit (Item 30, Appendix G)
- Torque wrench, 0-200 lb.-in. (Item 41, Appendix G)

### Materials/Parts:

- Four locknuts

### a. REMOVAL

1. Remove four locknuts (6), flatwashers (7), cap-screws (2), and flatwashers (1) from battery case (3) and pivoting tray (4). Discard locknuts.
2. Remove battery case (3) and strap (5) from pivoting tray (4).



### b. INSTALLATION

Install strap (5) and battery case (3) on pivoting tray (4) with four flatwashers (1), capscrews (2), flatwashers (7), and new locknuts (6). Torque locknuts to 40+/- 4 lb.-in. (4.52 +/- 0.45 N•m).

### Follow-on Tasks:

- Install battery (see paragraph 4-43).

---

## 4-45. BATTERY CABLES REPLACEMENT.

---

*This Task Covers:*

- |                            |                 |
|----------------------------|-----------------|
| a. Removal                 | c. Installation |
| b. Cleaning and inspection |                 |
- 

*initial Setup:*

**Equipment Conditions:**

- Engine starter switch set to OFF position (see paragraph 2-20).

**Tools/Test Equipment:**

- General mechanic's tool kit (item 30, Appendix G)

**References:**

- TM 9-6140-200-14

**Materials/Parts:**

- Marker tags (Item 28, Appendix F)
- Tie-down straps
- One locknut
- One springwasher

**General Safety instructions:**

- DO NOT perform battery system maintenance while smoking or near fire, flames, or sparks.
- 



- Remove ail jewelry such as I.D. tags, rings, bracelets, etc. if Jewelry contacts battery terminal, a direct short will result causing instant heating of Jewelry which will result in serious injury or death to personnel.
- DO NOT perform battery system checks or inspections while smoking or near fire, flames, or sparks. Battery gases may explode, causing serous injury or death to personnel.
- Sulfuric acid contained in batteries can cause serious burns. If battery corrosion or electrolyte makes contact with skin, eyes, or clothing, take immediate action to stop the corrosive burning effects. Failure to follow these procedures may result in serious injury or death to personnel.
  - Eyes.** Flush with cold water for no less than 15 minutes and immediately seek medical attention.
  - Skin.** Flush with large amounts of cold water until ail acid is removed. Seek medical attention as required.
  - Internal.** if corrosion or electrolyte is ingested, drink large amounts of water or milk. Follow with milk of magnesia, beaten egg, or vegetable oil. immediately seek medical attention.
  - Clothing/Equipment.** Wash area with large amounts of cold water. Neutralize acid with baking soda or household ammonia.

---

4-45. BATTERY CABLES REPLACEMENT (Con't).

---

**a. REMOVAL**

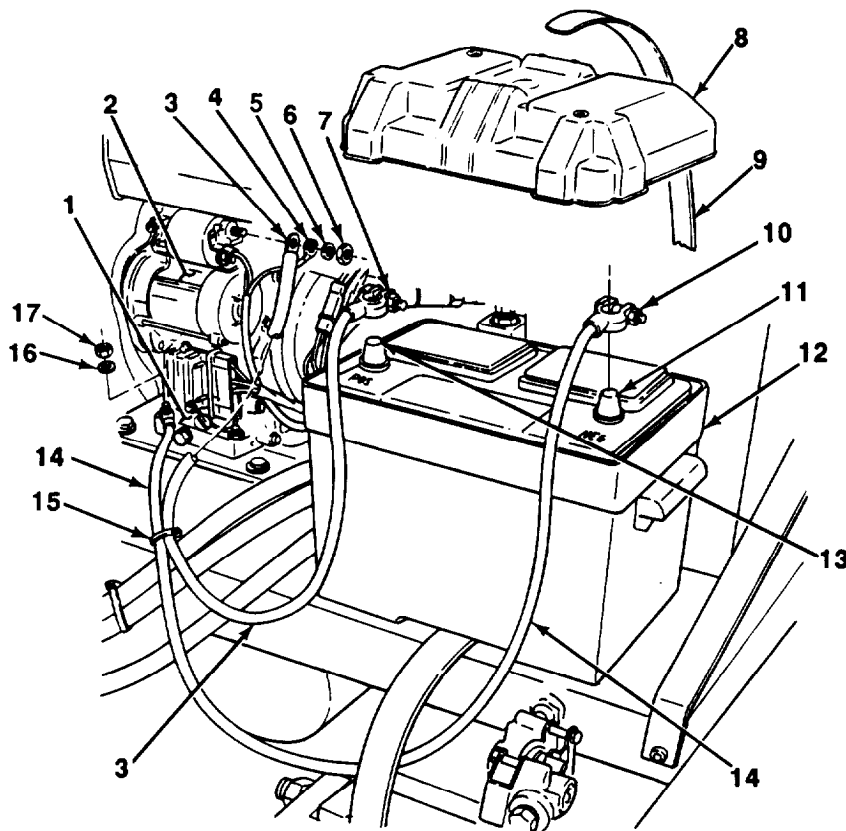
**WARNING**

Always disconnect negative (-) ground cable from negative (-) terminal of battery FIRST to avoid a short should a tool contact cables. Failure to follow this warning may result in serious injury or death to personnel.

NOTE

Battery cables should be tagged before removal. Refer to paragraph 4-18 for tagging instructions.

1. Unbuckle strap (9) and remove cover (8) from battery case (12).
2. Loosen nut (10) and remove negative (-) ground cable (14) from battery negative (-) terminal (11).
3. Loosen nut (7) and remove positive (+) cable (3) from battery positive (+) terminal (13).





---

**4-45. BATTERY CABLES REPLACEMENT (Con't).**

---

4. Remove locknut (17), flatwasher (16), and negative (-) ground cable (14) from crankcase (1). Discard locknut.
5. Remove nut (6), springwasher (5), engine wiring harness lead (4), and positive (+) cable (3) from starter (2). Discard springwasher.
6. Remove tie-down straps (15) from positive (+) cable (3) and negative (-) ground cable (14). Discard tie-down straps.

**b. CLEANING AND INSPECTION**

Inspect battery terminals and cable end connections for dirt or corrosion. Clean in accordance with TM 9-6140-200-14.

**c. INSTALLATION****WARNING**

Always connect negative (-) ground cable to negative (-) terminal of battery LAST to avoid a short should a tool contact cables. Failure to follow this warning may result in serious injury or death to personnel.

1. Install positive (+) cable (3) and engine wiring harness lead (4) on starter (2) with new springwasher (5) and nut (6).
2. Install negative (-) ground cable (14) on crankcase (1) with flatwasher (16) and new locknut (17).
3. Install positive (+) cable (3) on battery positive (+) terminal (13). Tighten nut (7).
4. Install negative (-) ground cable (14) on battery negative (-) terminal (11). Tighten nut (10).
5. Wrap positive (+) cable (3) and negative (-) ground cable (14) with new tie-down straps (15).

**CAUTION**

Avoid overtightening of strap, which may damage strap or buckle.

6. Install cover (8) on battery case (12). Fasten strap (9).

---

## 4-46. SIGNAL CONDITIONING BOX-TO-FORWARD JUNCTION BOX CABLE ASSEMBLY REPLACEMENT.

---

*This Task Covers:*

- |            |                 |
|------------|-----------------|
| a. Removal | b. Installation |
|------------|-----------------|
- 

*Initial Setup:*

**Equipment Conditions:**

- Intervehicular cable disconnected from signal conditioning box (see paragraph 2-7).
- Intradolly cable disconnected from forward junction box (see paragraph 2-7).

**Materials/Parts:**

- Marker tags (item 26, Appendix F)
- Tie-down straps

**Tools/Test Equipment:**

- General mechanic's tool kit (item 30, Appendix G)
- 

**NOTE**

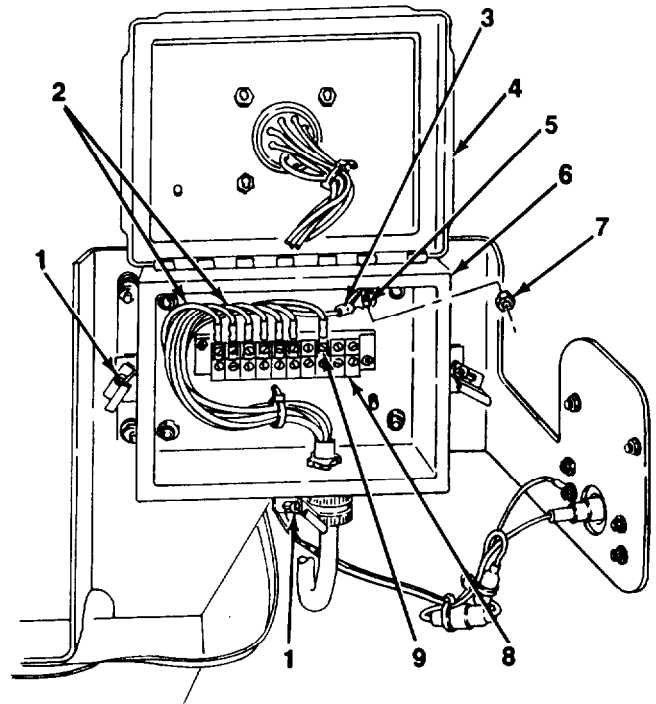
- All wires should be tagged before removal. Refer to paragraph 4-18 for tagging Instructions.
- Refer to electrical wiring diagrams for assistance (see paragraph 4-50).
- Remove tie-down straps as required. Ensure that new tie-down straps are used during installation.

**a. REMOVAL**

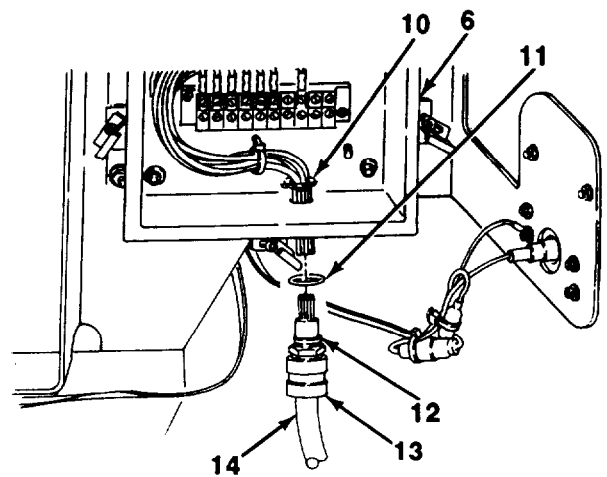
1. Loosen three screws (1) and open cover (4) of forward junction box (6).
2. Remove seven screws (9) and cable assembly wires (2) from positions 1 through 6 and 8 of terminal block (8).

**4-46. SIGNAL CONDITIONING BOX-TO-FORWARD JUNCTION BOX CABLE ASSEMBLY REPLACEMENT (Con't).**

3. Remove nut (7) and green ground wire (3) from top right screw (5).



4. Remove locknut (10) from cord connector (12).
5. Remove cord connector (12), sealing ring (11), and cable assembly (14) from forward junction box (6).
8. Loosen nut (13) and remove cable assembly (14) from cord connector (12).

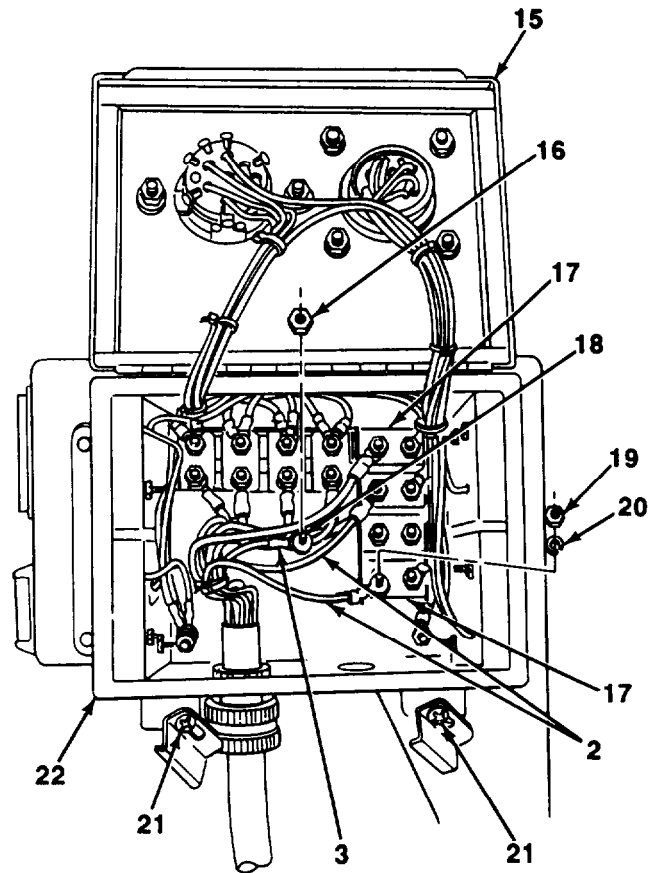


---

**4-46. SIGNAL CONDITIONING BOX-TO-FORWARD JUNCTION BOX CABLE ASSEMBLY REPLACEMENT (Con't).**

---

7. Loosen two screws (21) and open cover (15) of signal conditioning box (22).
8. Remove seven nuts (19) lockwashers (20) and cable assembly wires (2) from terminals of circuit breakers (17).
9. Remove nut (16) and green ground wire (3) from screw (18).

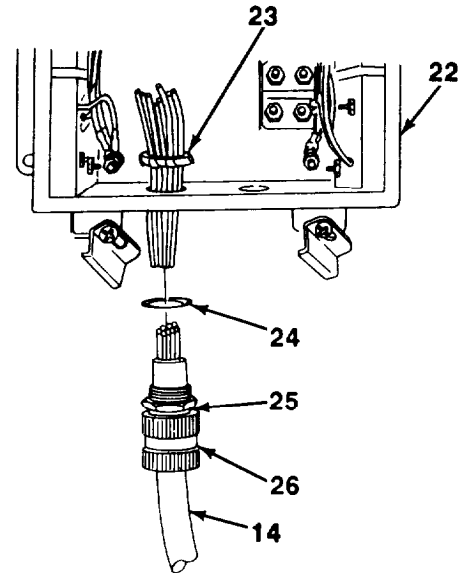


10. Remove locknut (23) from cord connector (25).
11. Remove cord connector (25), sealing ring (24), and cable assembly (14) from signal conditioning box (22).
12. Loosen nut (26) and remove cable assembly (14) from cord connector (25).

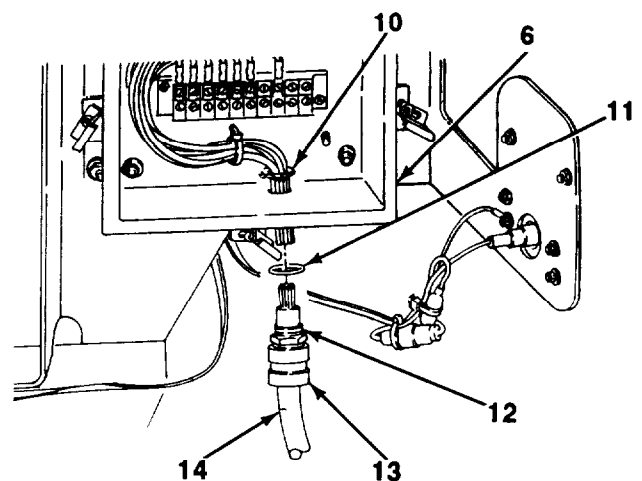
**4-46. SIGNAL CONDITIONING BOX-TO-FORWARD JUNCTION BOX CABLE ASSEMBLY REPLACEMENT (Con't).**

**b. INSTALLATION**

1. Install cable assembly (14) through cord connector (25) and tighten nut (26).
2. Install cord connector (25) and sealing ring (24) on cable assembly (14).
3. Route wires of cable assembly (14) through hole in signal conditioning box (22).
4. Position sealing ring (24) and cord connector (25) at signal conditioning box (22). install locknut (23) on cable assembly (14) and tighten locknut.



5. install green ground wire (3) on screw (18) with nut (16).
6. install seven cable assembly wires (2) on terminals of circuit breakers (17) with lockwashers (20) and nuts (19).
7. Close cover (15) of signal conditioning box (22) and tighten two screws (21).
8. Install cable assembly (14) through cord connector (12) and tighten nut (13).
9. install cord connector (12) and sealing ring (11) on cable assembly (14).
10. Route wires of cable assembly (14) through hole in forward junction box (6).
11. Position sealing ring (11) and cord connector (12) at foward junction box (6). Install locknut (10) on cable assembly (14) and tighten locknut.

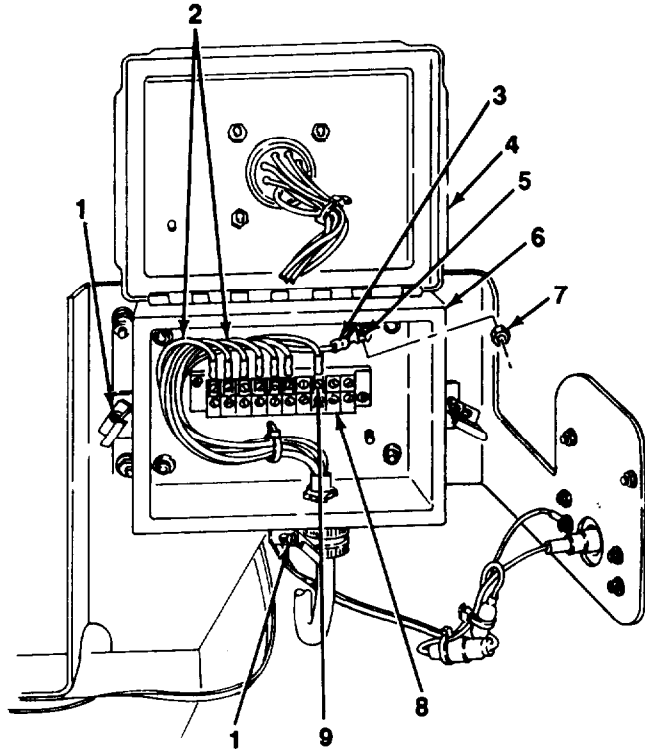


---

**4-46. SIGNAL CONDITIONING BOX-TO-FORWARD JUNCTION BOX CABLE ASSEMBLY REPLACEMENT (Con't).**

---

12. Install green ground wire (3) on top right screw (5) with nut (7).
13. Install seven cable assembly wires (2) on positions 1 through 6 and 8 of terminal block (8) with screws (9).
14. Close cover (4) of forward junction box (6) and tighten three screws (1).



**Follow-on Tasks:**

- Connect intradolly cable to forward junction box and rear junction box (see paragraph 2-11).
- Connect intervehicular cable to signal conditioning box and towing vehicle (see paragraph 2-11).
- Check operation of lights.

---

## 4-47. FRONT DOLLY MARKER CLEARANCE LIGHT CABLE ASSEMBLIES REPLACEMENT.

---

*This Task Covers:*

- a. Removal b. installation
- 

*Initial Setup:*

**Equipment Conditions:**

- intervehicular cable disconnected from towing vehicle (see paragraph 2-7).

**Tools/Test Equipment:**

- General mechanic's tool kit (item 30, Appendix G)

**Materials/Parts:**

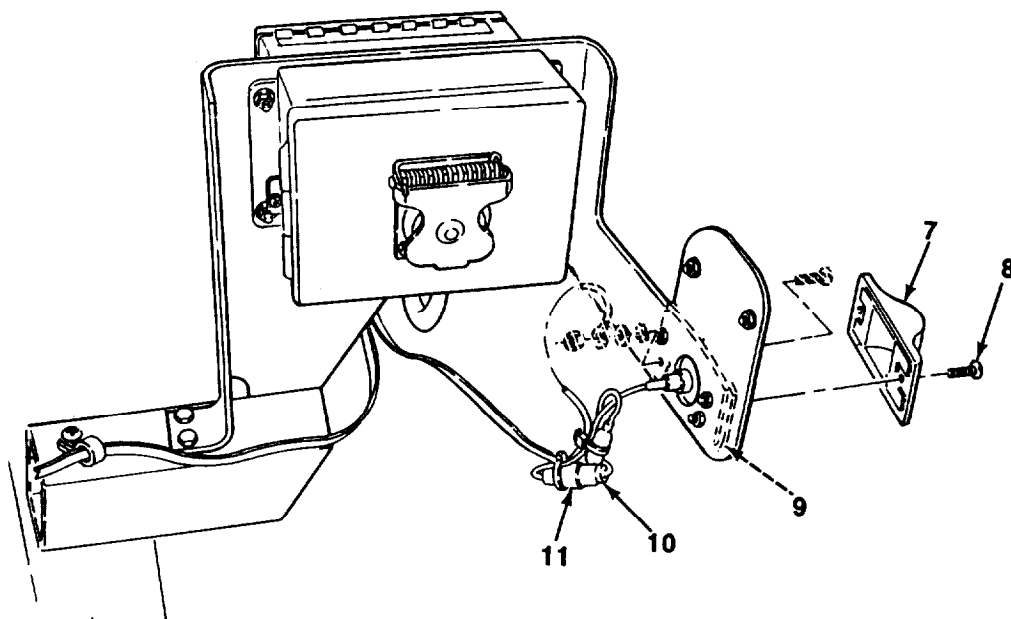
- Marker tags (item 28, Appendix F)
- Tie-down straps
- Two locknuts
- Two lockwashers

**NOTE**

- All wires should be tagged before removal. Refer to paragraph 4-18 for tagging Instructions.
- Refer to electrical wiring diagrams for assistance (see paragraph 4-50).

**a. REMOVAL**

1. On right side, cut tie-down straps from connector plugs (10 and 11). Disconnect cable assembly connector plug (11) from marker clearance light connector plug (10). Discard tie-down straps.
2. Remove two screws (8) and lens housing (7) from marker clearance light body (9).

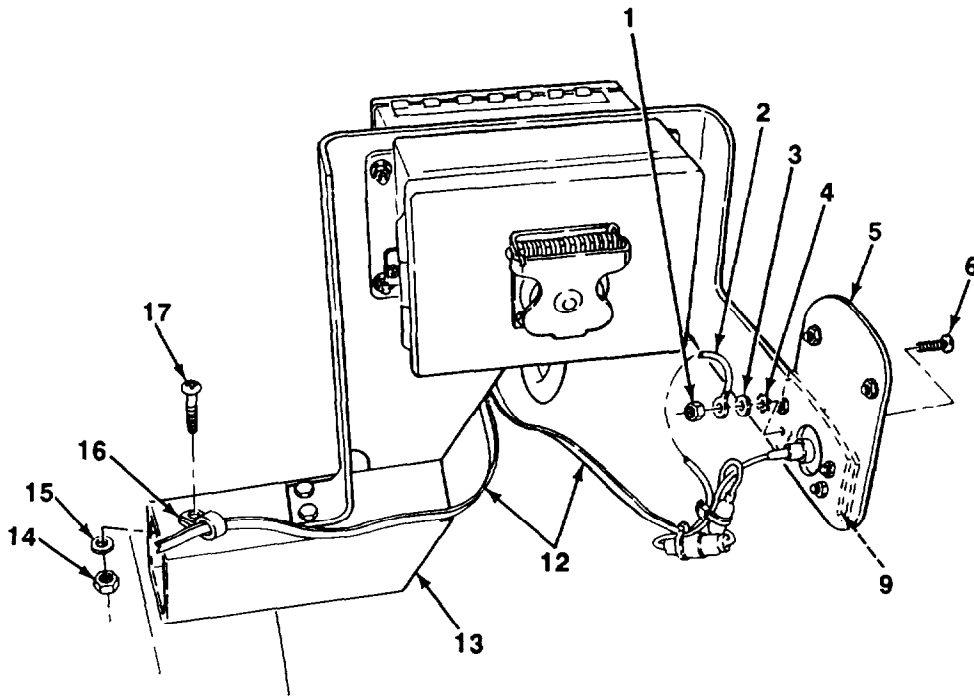


---

**4-47. FRONT DOLLY MARKER CLEARANCE LIGHT CABLE ASSEMBLIES  
REPLACEMENT (Con't).**

---

3. Remove locknut (1) ground wire (2) flatwasher (3) lockwasher (4), and screw (6) from marker clearance light body (9) and bracket (5). Discard locknut and lockwasher.
4. Repeat steps 1 through 3 for left side.
5. On right side, remove locknut (14), flatwasher (15), screw (17), clamp (16), and left side cable assembly (12) from brace (13). Discard locknut.
6. Cut tie-down straps from left side cable assembly (12) and hydraulic lines. Discard tie-down straps.



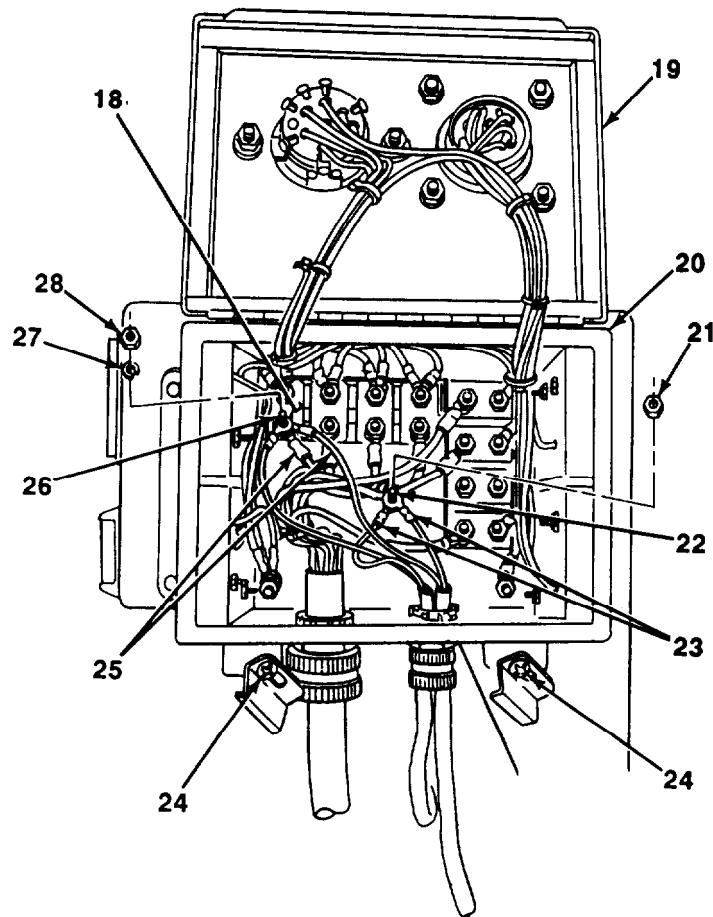


---

**4-47. FRONT DOLLY MARKER CLEARANCE LIGHT CABLE ASSEMBLIES  
REPLACEMENT (Con't).**

---

7. Loosen two screws (24) and open cover (19) of signal conditioning box (20).
8. Remove nut (28), lockwasher (27), and two black wires (25) from lower terminal (26) of top left circuit breaker (18).
9. Remove nut (21) and two black ground wires (23) from screw (22).

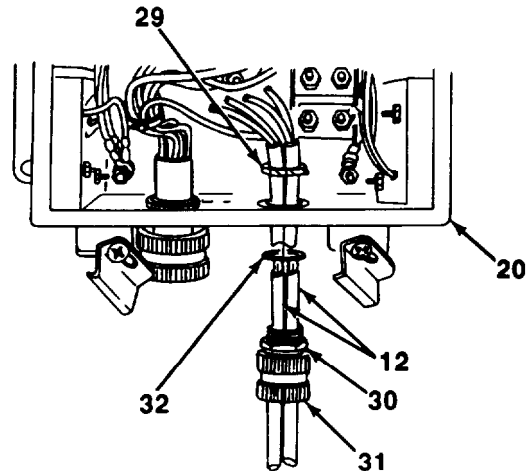


---

#### 4-47. FRONT DOLLY MARKER CLEARANCE LIGHT CABLE ASSEMBLIES REPLACEMENT (Con't).

---

10. Remove locknut (29) from cord connector (30).
11. Remove cord connector (30), sealing ring (32), and cable assemblies (12) from signal conditioning box (20).
12. Loosen nut (31) and remove cable assemblies (12) from cord connector (30).



#### **b. INSTALLATION**

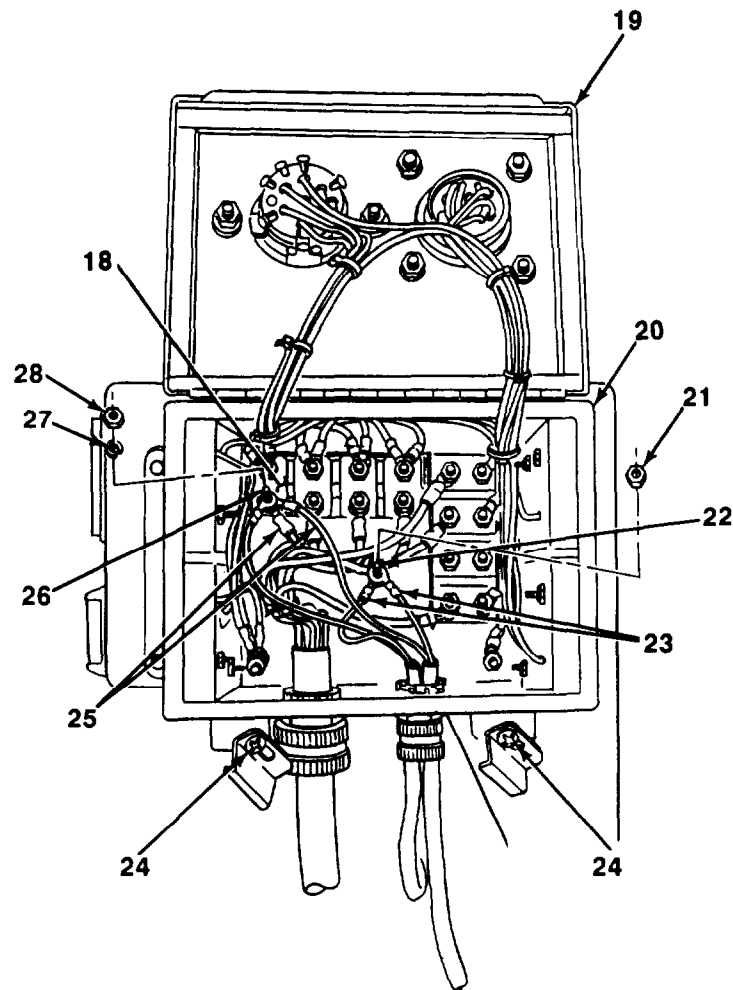
1. Install cable assemblies (12) through cord connector (30) and tighten nut (31).
2. Install sealing ring (32) on cable assemblies (12).
3. Route wires of cable assemblies (12) through hole in signal conditioning box (20).
4. Position sealing ring (32) and cord connector (30) at signal conditioning box (20). Install locknut (29) on cable assembly (12) and tighten locknut.

---

**4-47. FRONT DOLLY MARKER CLEARANCE LIGHT CABLE ASSEMBLIES  
REPLACEMENT (Con't).**

---

5. Install two black ground wires (23) on screw (22) with nut (21).
6. Install two black wires (25) on lower terminal (26) of top left circuit breaker (18) with lockwasher (27) and nut (28).
7. Close cover (19) and tighten two screws (24).

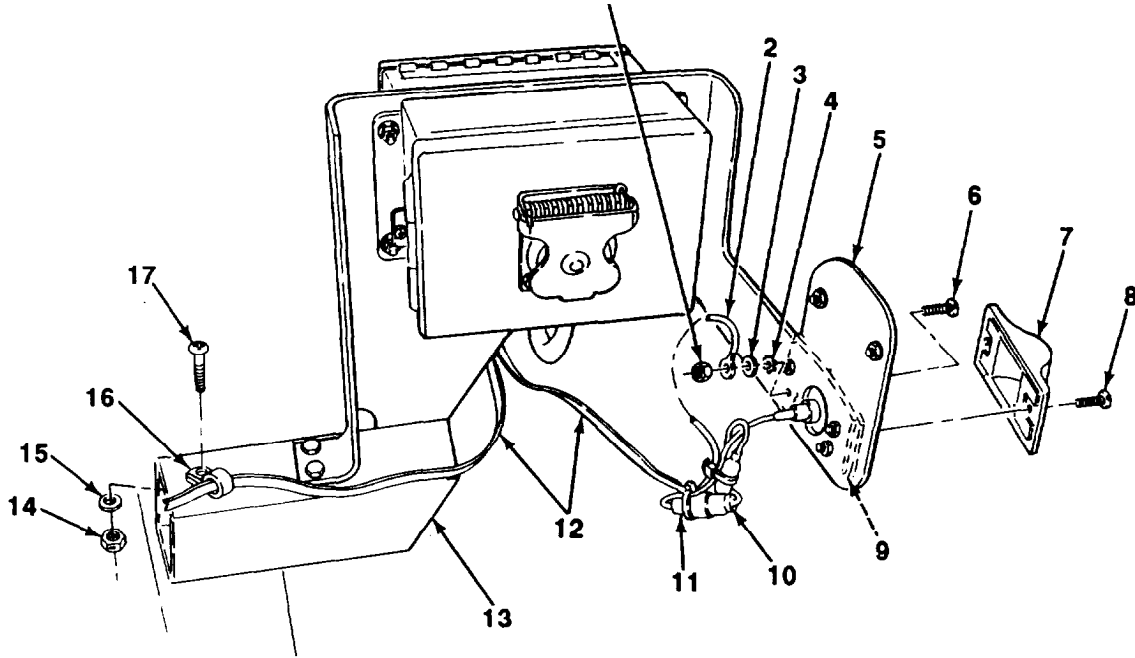


---

**4-47. FRONT DOLLY MARKER CLEARANCE LIGHT CABLE ASSEMBLIES  
REPLACEMENT (Con't).**

---

8. On right side, install left side cable assembly (12) on brace (13) with clamp (16), screw (17), fiatwasher (15), and new locknut (14).
9. Install screw (6), new lockwasher (4), fiatwasher (3), ground wire (2), and new locknut (1) on marker clearance light body (9) and bracket (5).
10. Install lens housing (7) on marker clearance light body (9) with two screws (8).
11. Connect cable assembly connector plug (11) to marker clearance light connector plug (10). Wrap connector plugs with new tie-down straps.
12. Repeat steps 9 through 11 for left side.



**Follow-On Task**

- Connect intervehicular cable to towing vehicle (see paragraph 2-11).
- Check operation of front dolly marker clearance lights.

---

**4-48. REAR DOLLY TAILLIGHT ASSEMBLY CABLE ASSEMBLY REPLACEMENT.**


---

This Task Covers:

- |            |                 |
|------------|-----------------|
| a. Removal | b. Installation |
|------------|-----------------|
- 

Initial Setup:

**Equipment Conditions:**

- Intradolly cable disconnected from rear junction box (see paragraph 2-7).

**Tools /Test Equipment:**

- General mechanic's tool kit (Item 30, Appendix G)

**Materials/Parts:**

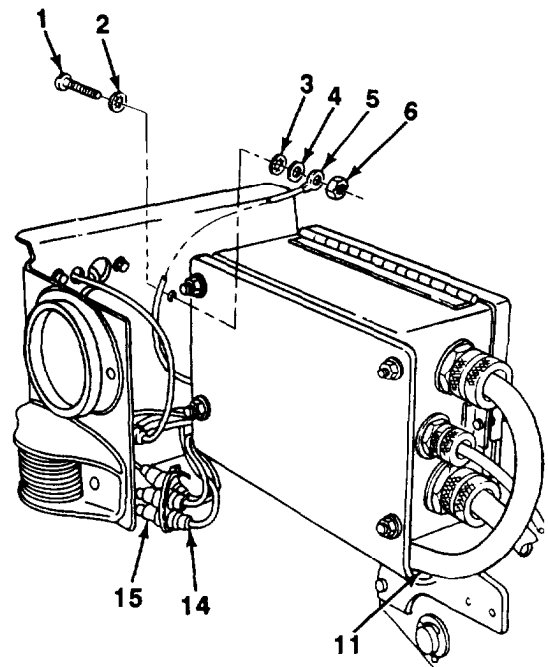
- Marker tags (Item 28, Appendix F)
- Tie-down straps
- One locknut
- Two lockwashers

**NOTE**

- Left and right side taillight assembly cable assemblies are replaced the same way except as noted. Right side taillight assembly cable assembly is illustrated.
- All wires should be tagged before removal. Refer to paragraph 4-18 for tagging instructions.
- Refer to electrical wiring diagrams for assistance (see paragraph 4-50).

**a. REMOVAL**

1. Cut tie-down strap from connector plugs (14 and 15). Disconnect five connector plugs (14) of tail-light assembly cable assembly (11) from five light connector plugs (15). Discard tie-down strap.
2. Remove locknut (6), cable assembly ground wire (5) flatwasher (4) lockwasher (3) panhead screw (1) and lockwasher (2). Discard locknut and lockwashers.

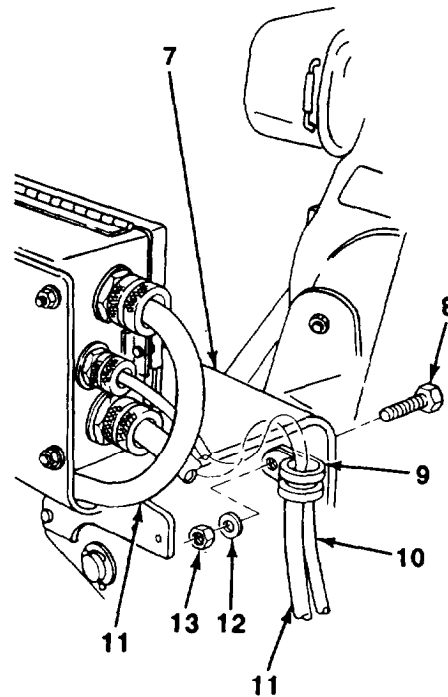


---

**4-48. REAR DOLLY TAILLIGHT ASSEMBLY CABLE ASSEMBLY REPLACEMENT (Con't).**

---

3. If removing left side taillight assembly cable assembly (11) remove locknut (13) flatwasher (12) screw (8) clamp (9), taillight assembly cable assembly, and identification light cable assembly (10) from bracket (7). Discard locknut.
4. If removing left side taillight assembly cable assembly (11), remove tie-down straps from taillight assembly cable assembly, Identification light cable assembly (10), and hydraulic lines. Discard tie-down straps.



5. Loosen three screws (19) and open cover (16) of rear junction box (20).

**NOTE**

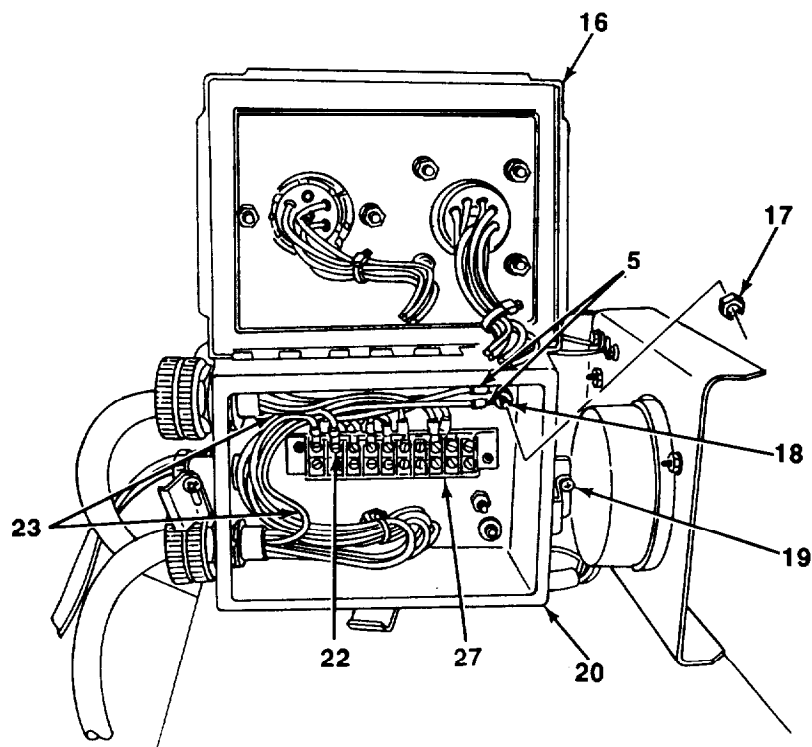
- Right side cable assembly wires are disconnected from positions 3, 4, 5, 6, and 8 of terminal block.
- Left side cable assembly wires are disconnected from positions 1, 2, 4, 5, and 8 of terminal block.

6. Remove five screws (22) and cable assembly wires (23) from terminal block (21).
7. Remove nut (17) and white and green ground wires (5) from upper right screw (18).

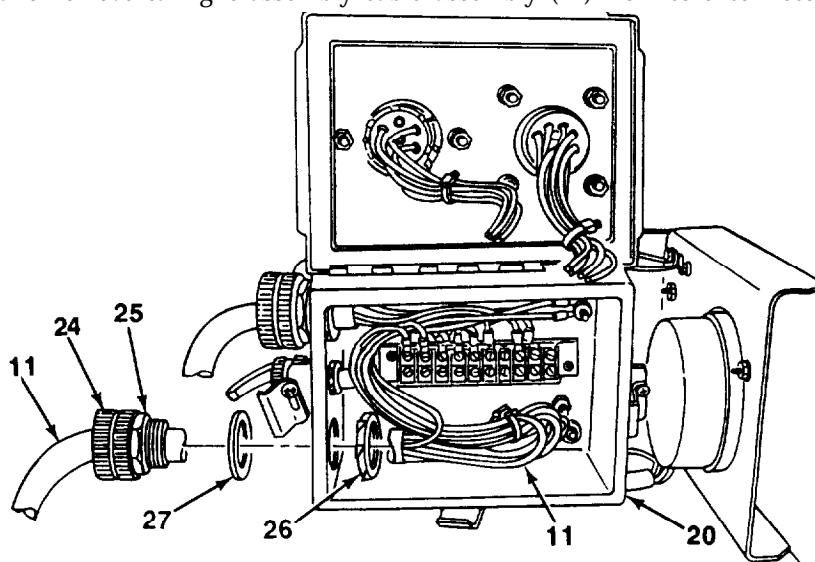
---

**4-48. REAR DOLLY TAILLIGHT ASSEMBLY CABLE ASSEMBLY REPLACEMENT (Con't).**


---



8. Remove locknut (26) from cord connector (25).
9. Remove cord connector (25), sealing ring (27), and taillight assembly cable assembly (11) from rear junction box (20).
10. Loosen nut (24) and remove taillight assembly cable assembly (11) from cord connector (25).



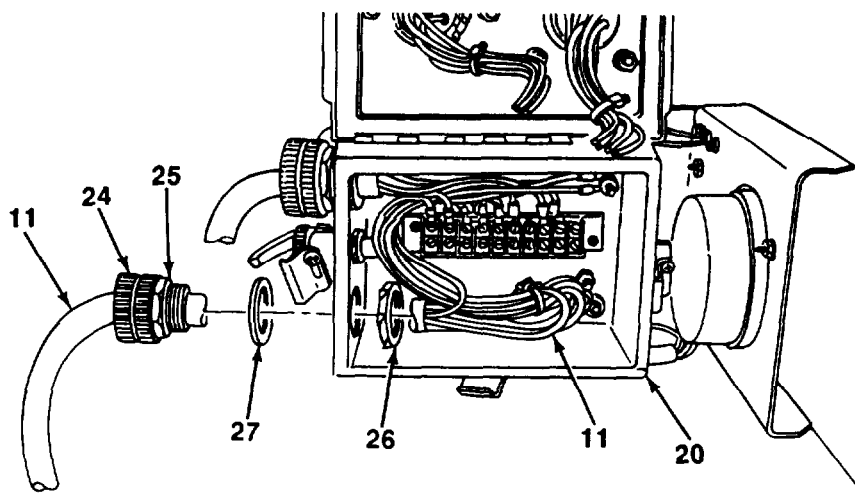
---

## 4-48. REAR DOLLY TAILLIGHT ASSEMBLY CABLE ASSEMBLY REPLACEMENT (Con't).

---

### b. INSTALLATION

1. Install taillight assembly cable assembly (11) through cord connector (25) and tighten nut (24).
2. Install sealing ring (27) on wires of taillight assembly cable assembly (11).
3. Route wires of taillight assembly cable assembly (11) through hole in rear junction box (20).
4. Position sealing ring (27) and cord connector (25) at rear junction box (26). Install locknut (26) on taillight assembly cable assembly (11) and tighten locknut.



5. Install white and green ground wires (5) on upper right screw (18) with nut (17).

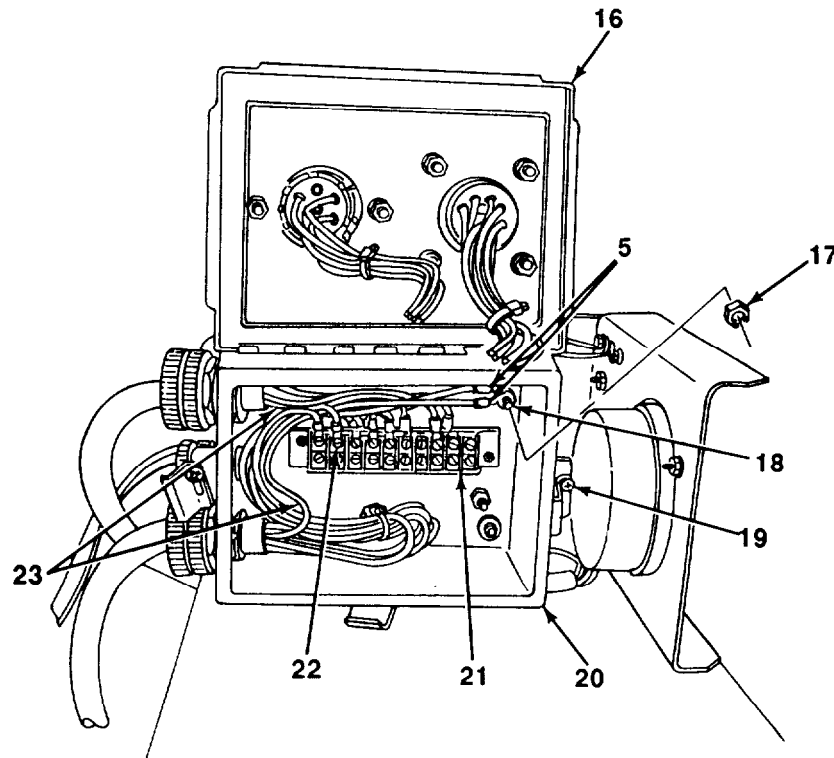
#### NOTE

- Right side cable assembly wires are connected to positions 3, 4, 5, 6, and 8 of terminal block.
- Left side cable assembly wires are connected to positions 1,2,4,5, and 8 of terminal block.

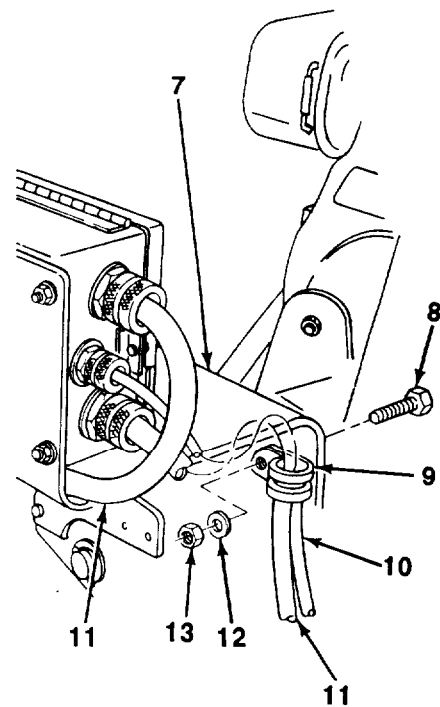
6. Install five cable assembly wires (23) to terminal block (21) with five screws (22).
7. Close cover (16) and tighten three screws (19).



4-48. REAR DOLLY TAILLIGHT ASSEMBLY CABLE ASSEMBLY REPLACEMENT (Con't).



8. If left side taillight assembly cable assembly (11) was removed, Install taillight assembly cable assembly and identification light cable assembly (10) on bracket (7) with clamp (9), screw (8), flat-washer (12), and new locknut (13).

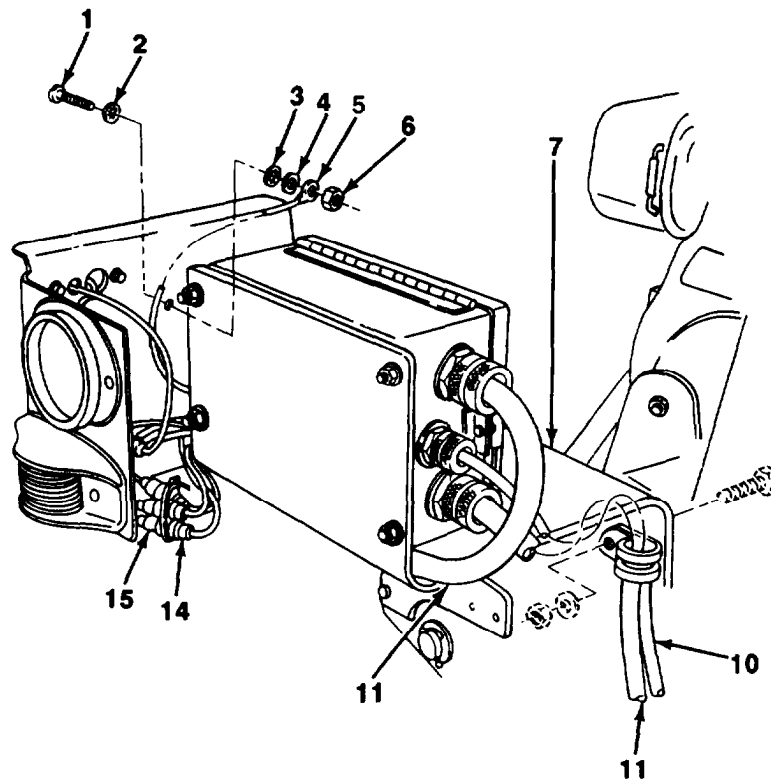


---

**4-48. REAR DOLLY TAILLIGHT ASSEMBLY CABLE ASSEMBLY REPLACEMENT (Con't).**

---

9. Connect five connector plugs (14) of taillight assembly cable assembly (11) to five light connector plugs (15). Wrap connector plugs with new tie-down strap.
10. Install new lookwasher (2), panhead screw (1), new lockwasher (3), flatwasher (4), cable assembly ground wire (5) and new locknut (6).
11. If left side taillight assembly cable assembly (11) was removed, wrap taillight assembly cable assembly, identification light cable assembly (10), and hydraulic lines with new tie-down straps.



Follow-on Tasks:

- Connect intradolly cable to rear junction box (see paragraph 2-11).
- Check operation of rear dolly lights.

---

**4-49. IDENTIFICATION LIGHT CABLE ASSEMBLY REPLACEMENT.**


---

This Task Covers:

- a. Removal b. Installation
- 

Initial Setup:

**Equipment Conditions:**

- Intradolly cable disconnected from rear junction box (see paragraph 2-7).

**Tools/Teat Equipment:**

- General mechanic's tool kit (Item 30, Appendix G)

**Materials/Parts:**

- Marker tags (Item 28, Appendix F)
  - Tie-down straps
  - One lockwasher
  - Two locknuts
- 

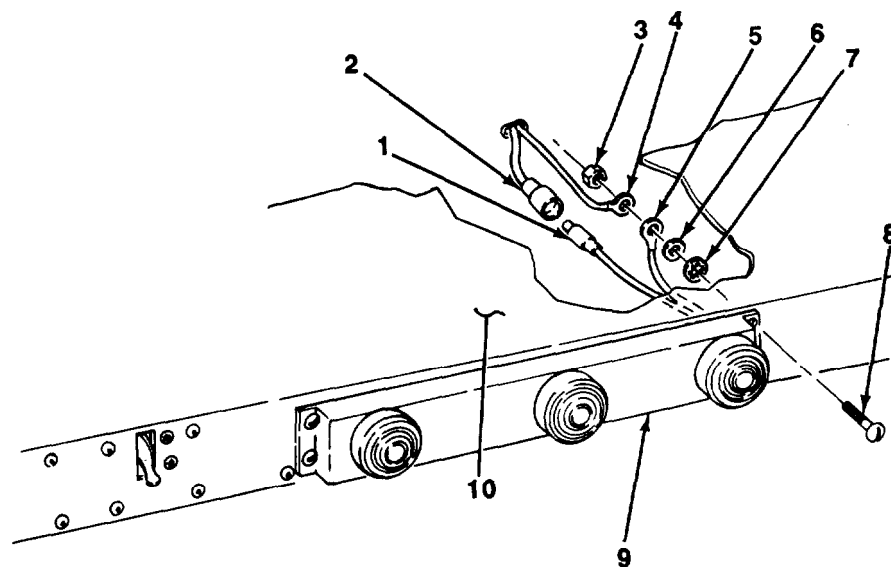
**NOTE**

- All wires should be tagged before removal. Refer to paragraph 4-18 for tagging instructions.
- Refer to electrical wiring diagrams for assistance (see paragraph 4-50).

**a. REMOVAL**

**NOTE**

1. Disconnect cable assembly connector plug (2) from identification light connector plug (1).
2. Remove locknut (3), two ground wires (4 and 5), flatwasher (6), lockwasher (7), and panhead screw (6) from identification light (9) and pivoting tray (10). Discard locknut and lock washer.

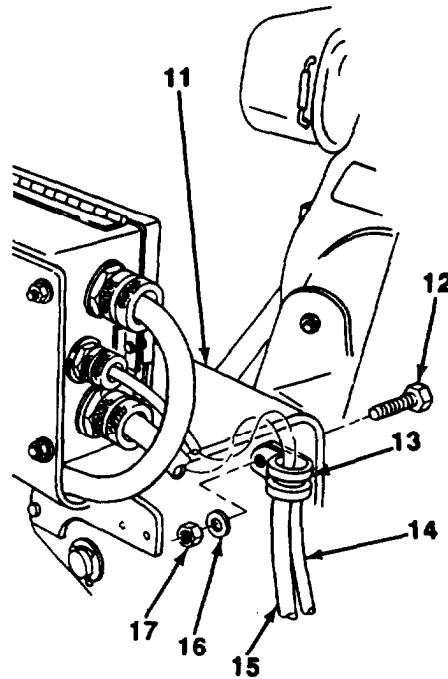


---

**4-49. IDENTIFICATION LIGHT CABLE ASSEMBLY REPLACEMENT (Con't).**

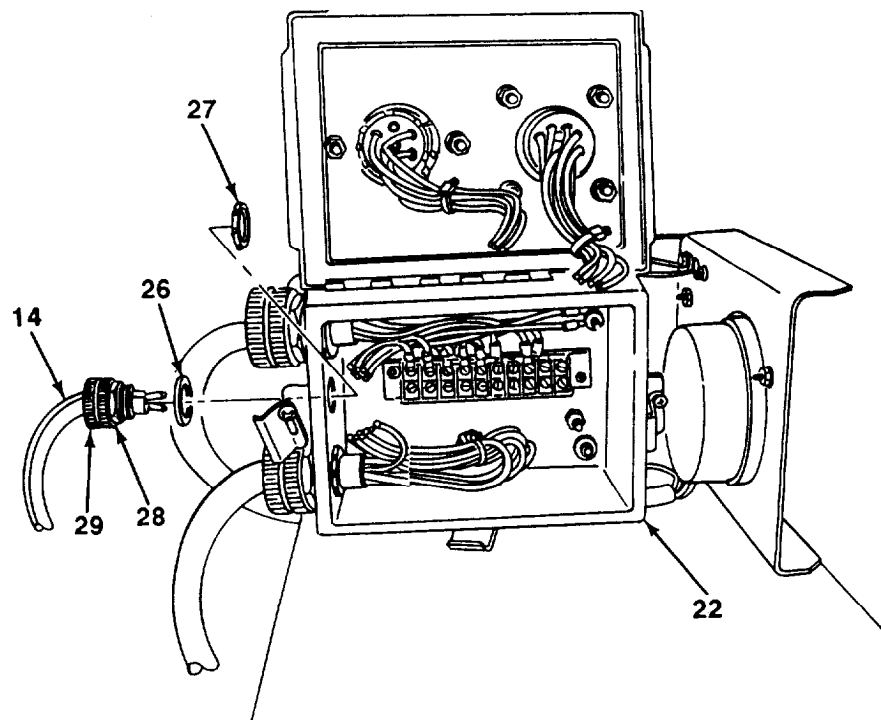
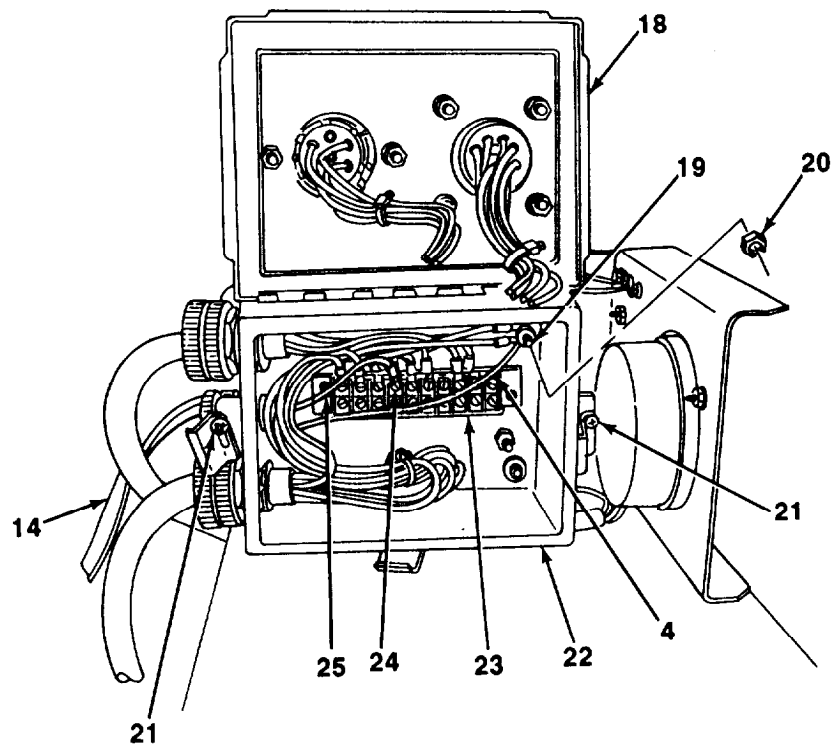
---

3. Remove tie-down straps from identification light cable assembly (14), taillight assembly cable assembly (15) and hydraulic lines. Discard tie-down straps.
4. Remove locknut (17), flatwasher (16), screw (12), clamp (13), identification light cable assembly (14) and taillight assembly cable assembly (15) from bracket (11). Discard locknut.



5. Loosen three screws (21) and open cover (18) of rear junction box (22).
6. Remove screw (24) and black wire (25) of identification light cable assembly (14) from position 4 on terminal block (23).
7. Remove nut (20) and ground wire (4) from upper right screw (19).
8. Remove locknut (27) from cord connector (28).
9. Remove cord connector (28), sealing ring (26) and identification light cable assembly (14) from rear junction box (22).
10. Loosen nut (29) and remove identification light cable assembly (14) from cord connector (28).

4-49. IDENTIFICATION LIGHT CABLE ASSEMBLY REPLACEMENT (Con't).



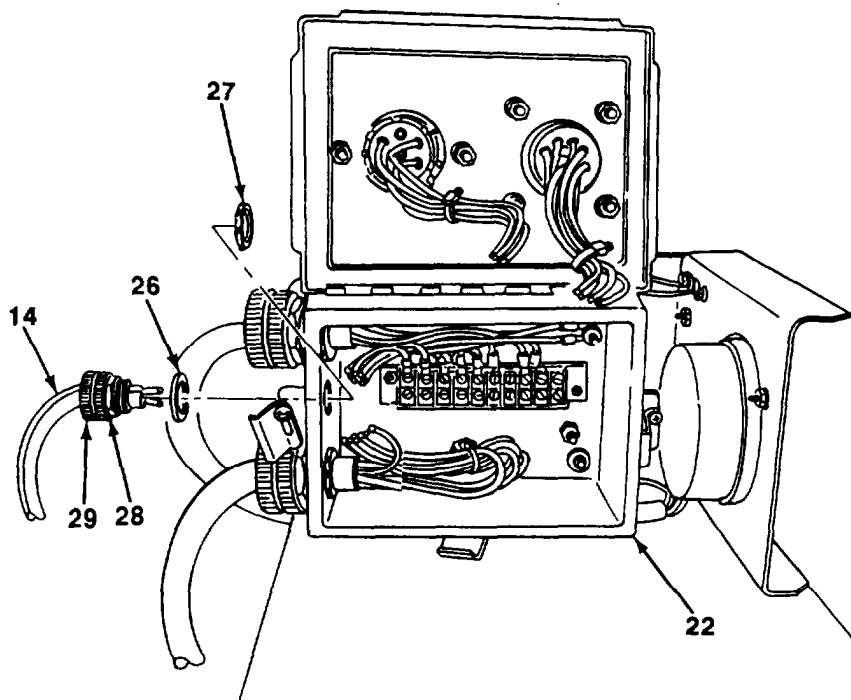
---

4-49. IDENTIFICATION LIGHT CABLE ASSEMBLY REPLACEMENT (Con't).

---

**b. INSTALLATION**

1. Install identification light cable assembly (14) through cord connector (28) and tighten nut (26).
2. Install sealing ring (26) on wires of identification light cable assembly (14).
3. Route wires of identification light cable assembly (14) through hole in rear junction box (22).
4. Position sealing ring (26) and cord connector (28) at rear junction box (22). Install locknut (27) on identification light cable assembly (14) and tighten locknut.

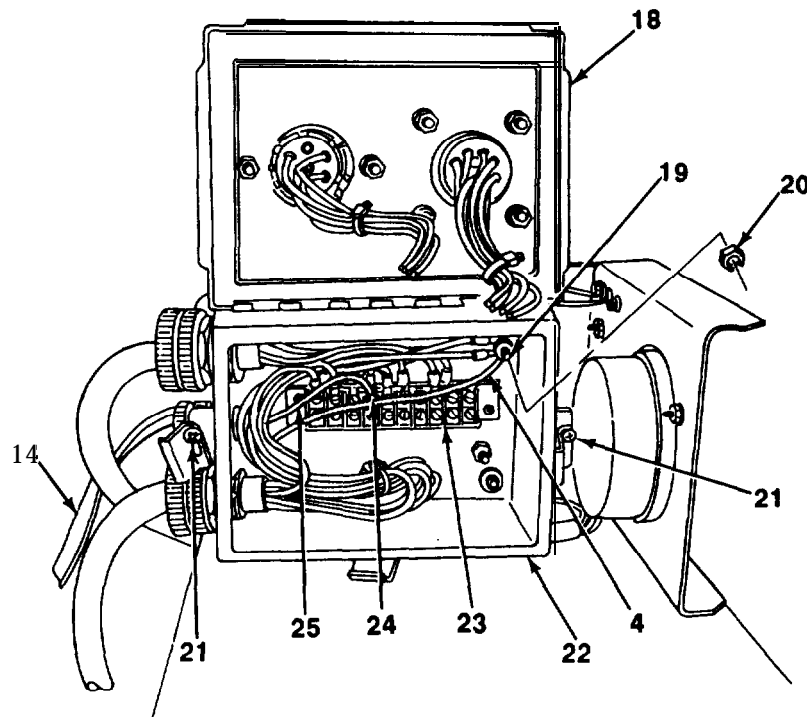


---

**4-49. IDENTIFICATION LIGHT CABLE ASSEMBLY REPLACEMENT (Con't).**

---

5. Install ground wire (4) on upper right screw (19) with nut (20).
6. Install black wire (25) of identification light cable assembly (14) on position 4 on terminal block (23) with screw (24).
7. Close cover (18) and tighten three screws (21).

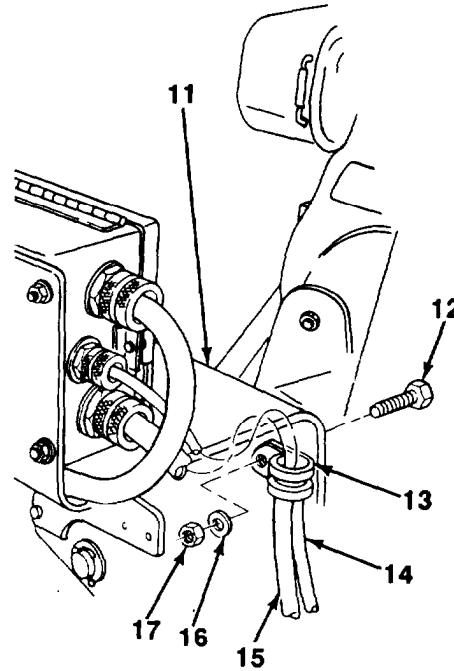


---

**4-49. IDENTIFICATION LIGHT CABLE ASSEMBLY REPLACEMENT (Con't).**

---

8. install identification light cable assembly (14) and taillight assembly cable assembly (15) on bracket (11) with clamp (13), screw (12), flatwasher (16), and new locknut (17).



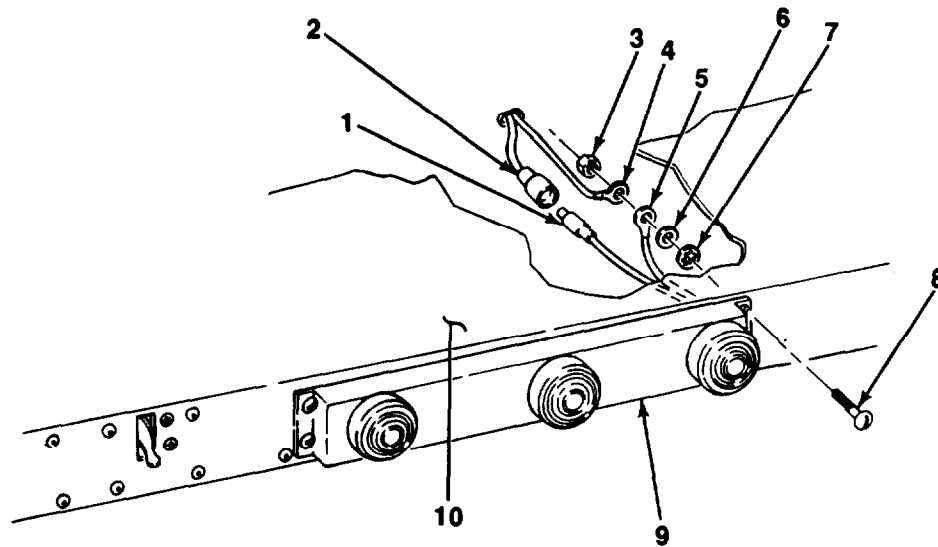
9. Connect cable assembly connector plug (2) to identification light connector plug (1).
10. Install panhead screw (a), new lockwasher (7), flatwasher (6), two ground wires (4 and 5), and new locknut (3) to identification light (9) and pivoting tray (10).
11. Wrap identification light cable assembly (14), taillight assembly cable assembly (15), and hydraulic lines with new tie-down straps.



---

**4-49. IDENTIFICATION LIGHT CABLE ASSEMBLY REPLACEMENT (Con't).**

---

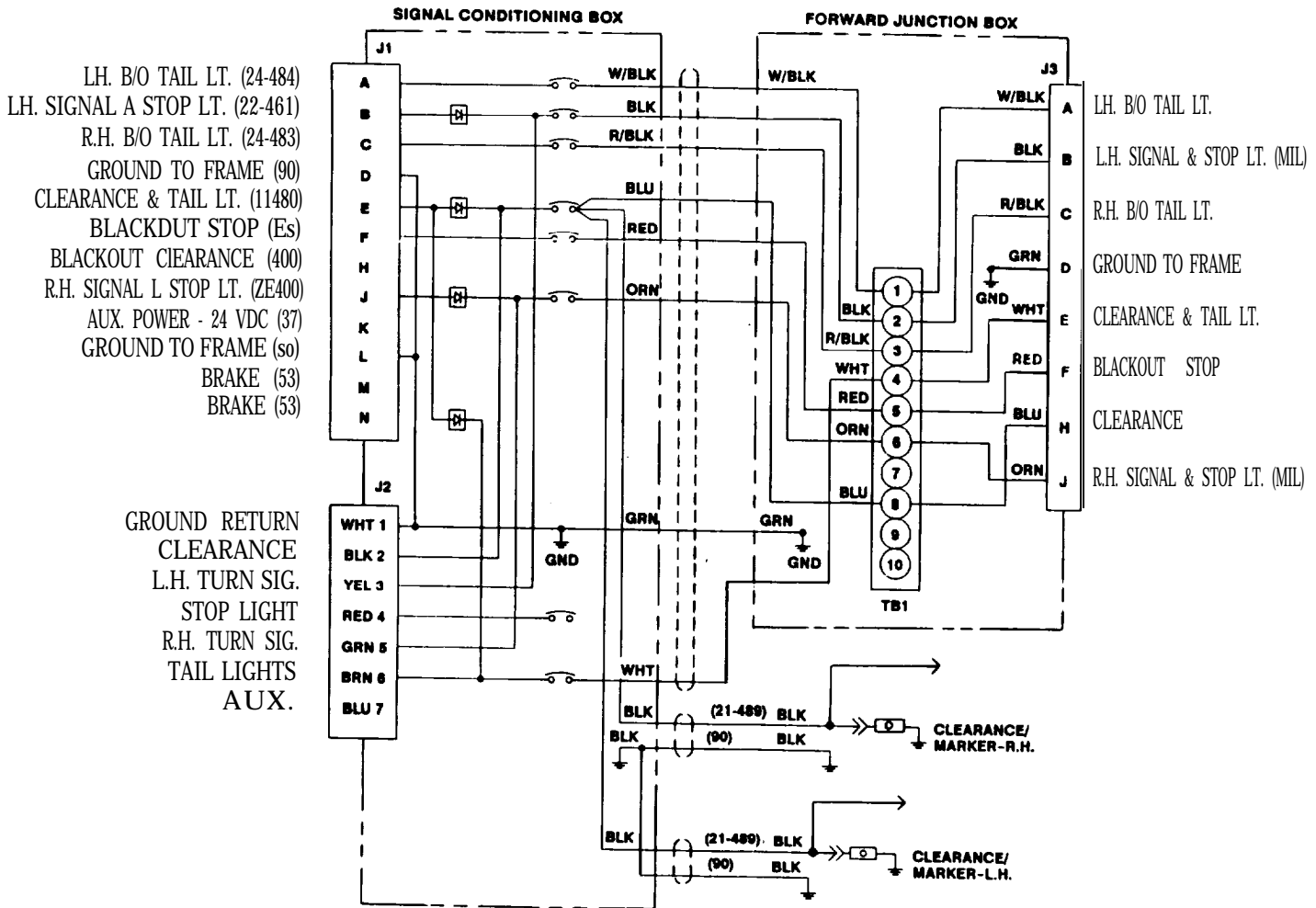
**Follow-on Tasks:**

- Connect intradolly cable to rear junction box (see paragraph 2-11).
- Check operation of identification light.

4-50. WIRING DIAGRAMS.

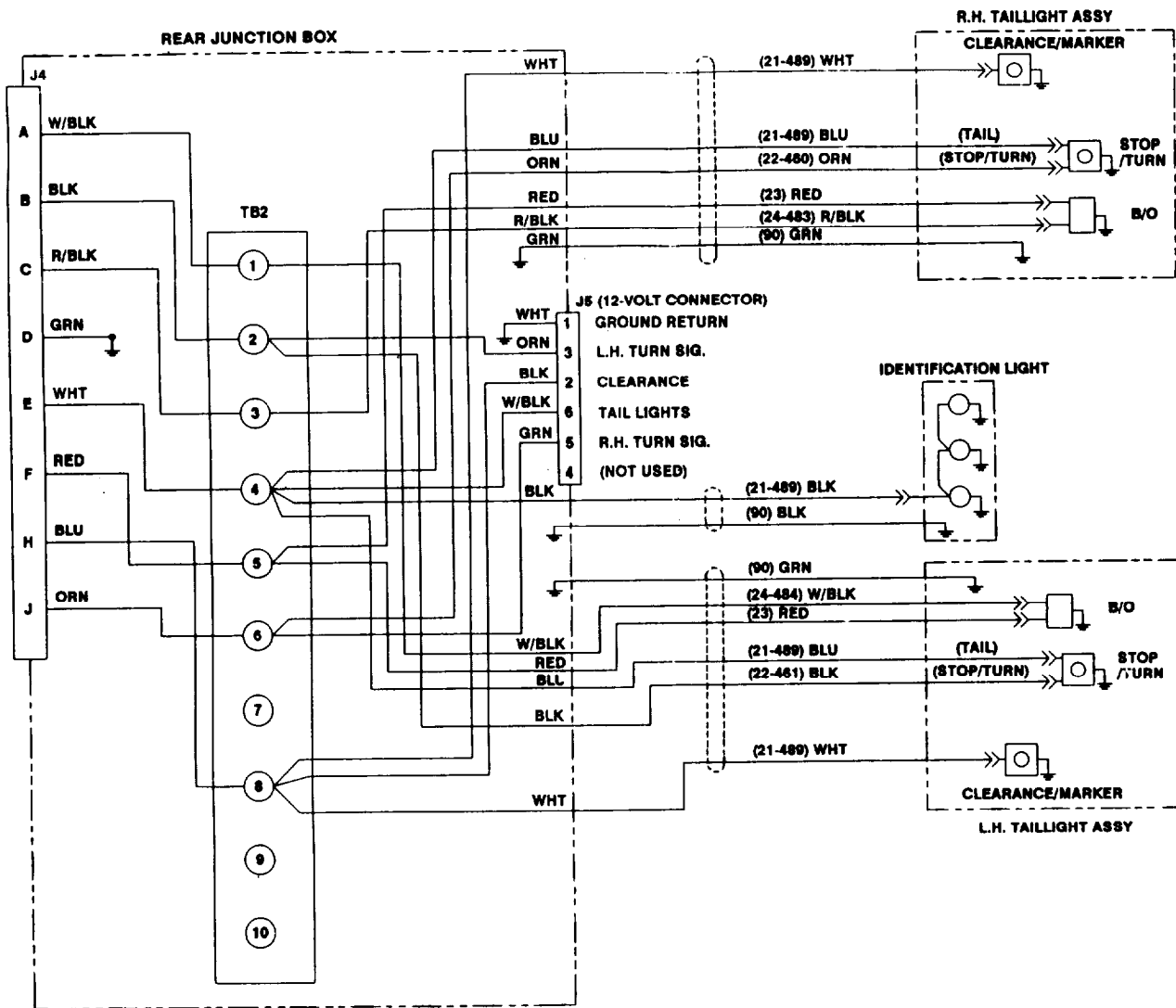
NOTE

- This paragraph contains wiring diagrams for the front and rear dolly lights. Refer to these diagrams when performing electrical troubleshooting or maintenance.
- Refer to paragraph 4-135 for engine wiring diagram.



FRONT DOLLY WIRING DIAGRAM

4-50. WIRING DIAGRAMS (Con't).



REAR DOLLY WIRING DIAGRAM



**Section VII. FRONT AXLE ASSEMBLY MAINTENANCE**

<b>Paragraph Number</b>	<b>Paragraph Title</b>	<b>Page Number</b>
4-51.	Safety Chains Replacement .....	4-111
4-52.	Safety Chains Mounting Replacement .....	4-113
4-53.	Front Drawbar Replacement .....	4-114
4-54.	Steering Knuckle Assembly Replacement .....	4-116
4-55.	Front Axle Alinement Check .....	4-119

**4-51. SAFETY CHAINS REPLACEMENT.**

This Task Covers:

- |            |                 |
|------------|-----------------|
| a. Removal | b. Installation |
|------------|-----------------|

/nifia/ Setup:

**Equipment Conditions:**

- Parking brake lever set to ON position (see paragraph 2-2).

**Materials/Parts:**

- Two cotter pins

**Tools/Test Equipment:**

- General mechanic's tool kit (Item 30, Appendix G)

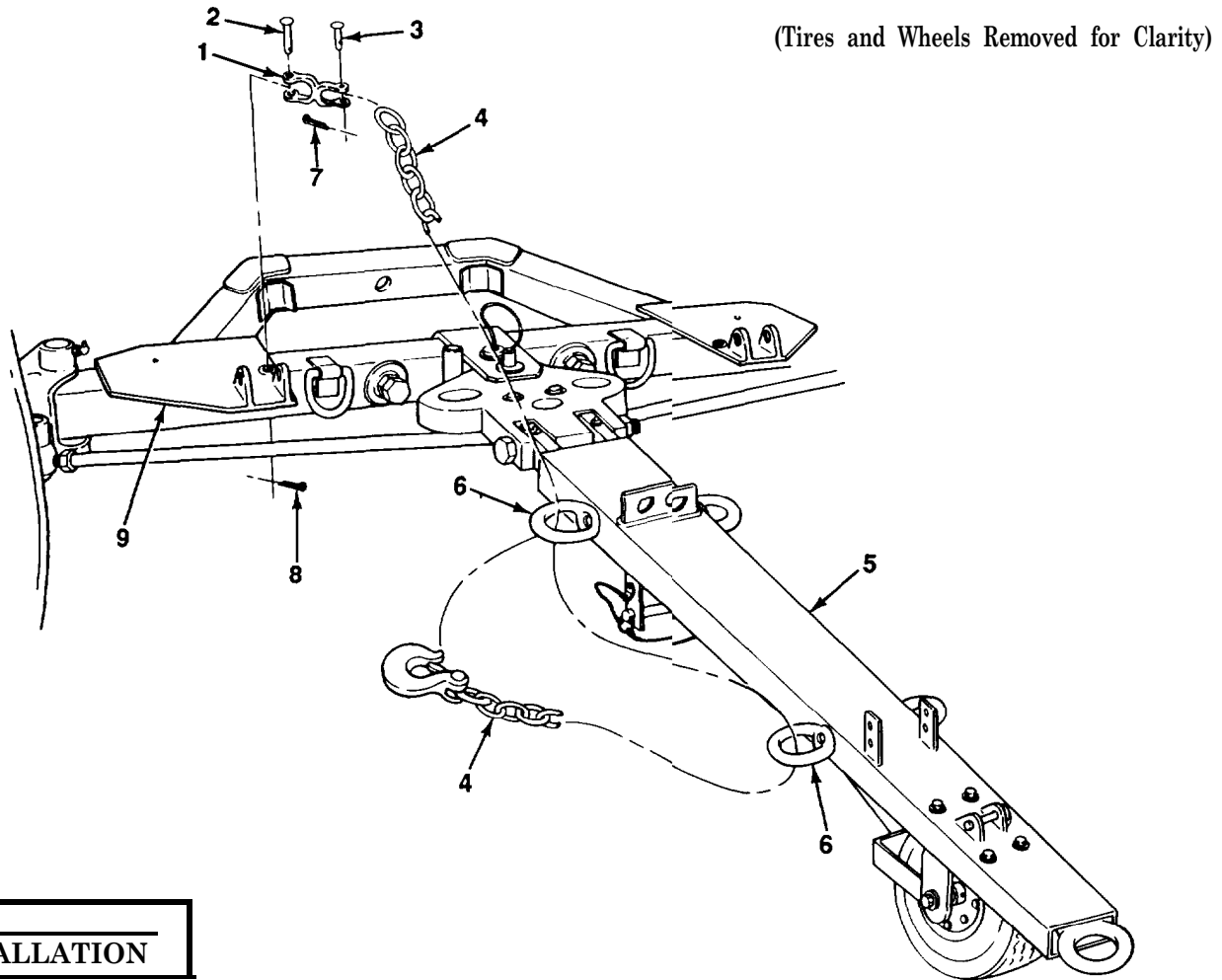
---

4-51. SAFETY CHAINS REPLACEMENT (Con't).

---

**a. REMOVAL**

1. Remove cotter pin (8) pin (2), and double link clevis (1) from front axle mounting plate (9). Discard cotter pin.
2. Remove cotter pin (7) pin (3) and double link clevis (1) from safety chain (4). Discard cotter pin.
3. Pull safety chain (4) through two eyenuts (6) on front drawbar (5) and remove safety chain.



**b. INSTALLATION**

1. Install safety chain (4) through two eyenuts (6) on front drawbar (5).
2. Install double link clevis (1) on safety chain (4) with pin (3) and new cotter pin (7).
3. Install double link clevis (1) on front axle mounting plate (9) with pin (2) and new cotter pin (8).

---

**4-52. SAFETY CHAINS MOUNTING REPLACEMENT.**

---

This Task Covers:

- a. Removal b. Installation
- 

Initial Setup:

**Equipment Conditions:**

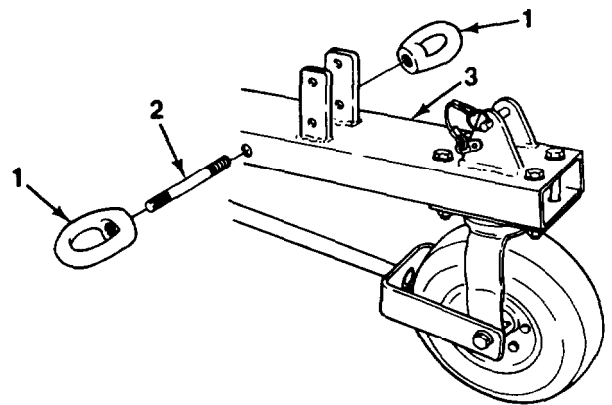
- Safety chains removed (see paragraph 4-51).

**Tools/Test Equipment:**

- General mechanic's tool kit (Item 30, Appendix G)
- 

**a. REMOVAL**

1. Remove two eyenuts (1) from rod (2).
2. Remove rod (2) from front drawbar (3).

**b. INSTALLATION**

1. Install rod (2) through holes in front drawbar (3) so that the same number of threads show on each end.
2. Install two eyenuts (1) on rod (2).

**Follow-on Tasks:**

- Install safety chains (see paragraph 4-51).

---

## 4-53. FRONT DRAWBAR REPLACEMENT.

---

*This Task Covers:*

a. Removal

b. Installation

---

*Initial Setup:*

### Equipment Conditions:

- Safety chains removed (see paragraph 4-51).
- Intervehicular air hoses removed (see paragraph 4-72).

### Materials/Parts:

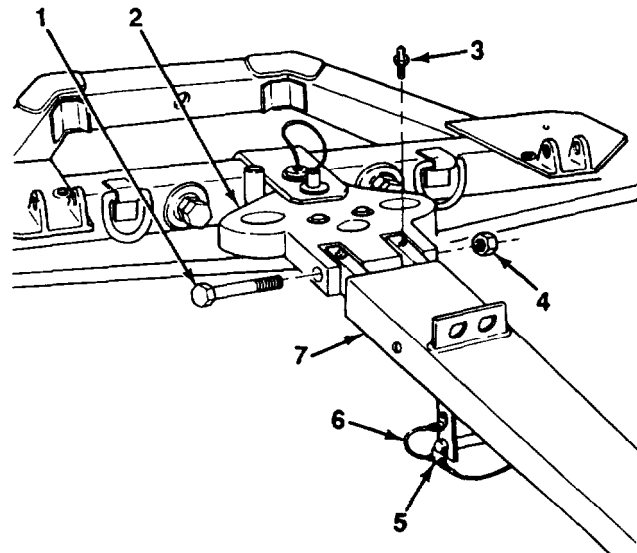
- One locknut
- Two grease fittings

### Tools/Test Equipment:

- General mechanic's tool kit (Item 30, Appendix G)
  - Socket wrench set, 3/4 in. drive (Item 39, Appendix G)
  - Torque wrench, 0-600 lb.-ft. (Item 43, Appendix G)
- 

#### **a. REMOVAL**

1. Remove locknut (4), bolt (1), and front drawbar (7) from steering link (2). Discard locknut.
2. Remove two grease fittings (3) from front drawbar (7). Discard grease fittings.
3. If hitch pin and safety pin (5) for handle stowage and detent pin for telescopic brace are damaged, remove with lanyard assemblies (6) (see paragraph 4-99).





---

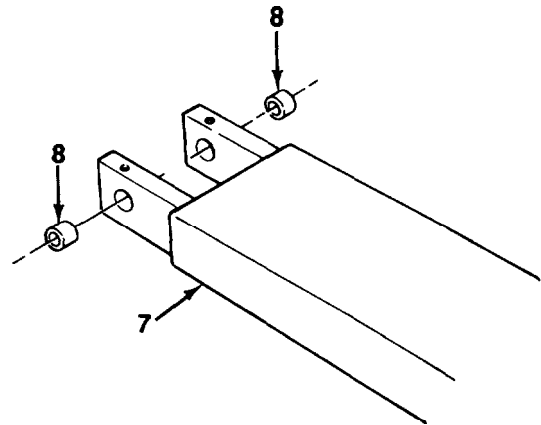
**4-53. FRONT DRAWBAR REPLACEMENT (Con't).**


---

**NOTE**

Perform steps 4 through 7 if components are damaged or if replacing front drawbar.

4. Remove data plates (see paragraph 4-105).
5. Remove safety chains mounting (see paragraph 4-52).
6. Remove dummy couplings (see paragraph 4-87).
7. Remove caster wheel assembly (see paragraph 4-91).



8. If bushings (8) are damaged, notify Direct Support to remove from front drawbar (7).

<b>b. INSTALLATION</b>
------------------------

1. If removed, have Direct Support install bushings (8) in front drawbar (7).
2. If removed, install caster wheel assembly (see paragraph 4-91).
3. If removed, install dummy couplings (see paragraph 4-87).
4. If removed, Install safety chains mounting (see paragraph 4-52).
5. If removed, install data plates (see paragraph 4-105).
6. If removed, install hitch pin and safety pin (5) for handle stowage and detent pin for telescopic brace with lanyard assemblies (6) (see paragraph 4-99).
7. Install two new grease fittings (3) on front drawbar (7).
8. Install front drawbar (7) on steering link (2) with bolt (1) and new locknut (4). Torque locknut to 500-550 lb.-ft. (678-746 N•m).

**Follow-on Tasks:**

- Install intervehicular air hoses (see paragraph 4-72).
- Install safety chains (see paragraph 4-51).
- Lubricate front drawbar (see Lubrication Instructions, Chapter 3, Section I).

---

**4-54. STEERING KNUCKLE ASSEMBLY REPLACEMENT.**

---

This Task Covers:

- |  |   |
|--|---|
| <ul style="list-style-type: none"> <li>a. Removal</li> <li>b. Cleaning and Inspection</li> </ul> | <ul style="list-style-type: none"> <li>c. Installation</li> </ul> |
|--|---|
- 

Initial Setup:

**Equipment Conditions:**

- Hub and brakedrum removed (see paragraph 4-75).
- Front dolly air line disconnected from airbrake chamber (see paragraph 4-72).

**Tools/Test Equipment:**

- General mechanic's tool kit (Item 30, Appendix G)
- Compressor unit (Item 4, Appendix G)
- Torque wrench, 0-175 lb.-ft. (Item 42, Appendix G)

**Personnel Required: Two**

**General Safety instructions:**

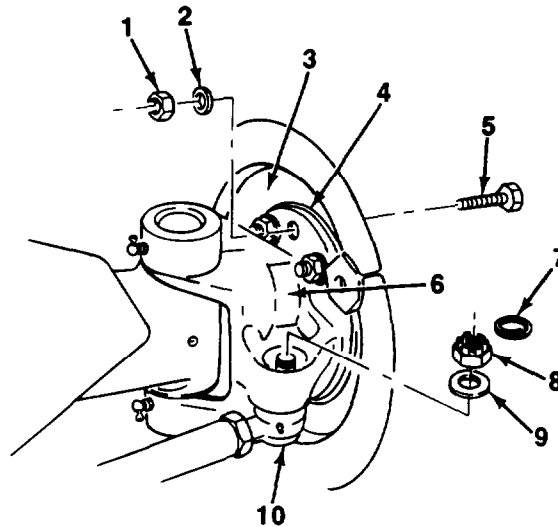
- Dry cleaning solvent is flammable and must not be used near an open flame. Use only in a well-ventilated area.
  - Compressed air used for cleaning purposes should never exceed 30 psi (207 kPa).
- 

**Materials/Parts:**

- Grease (Item 19, Appendix F)
- Dry cleaning solvent (Item 27, Appendix F)
- One roll pin
- One thrustwasher
- Two grease fittings
- Two welch plugs
- Eight lockwashers

**a. REMOVAL**

1. Remove eight nuts (1), lockwashers (2), cap screws (5), and spider assembly (3) with brakeshoes and wedge brake components from spindle (4) of steering knuckle assembly (6). Discard lockwashers.
2. Remove circle cotter (7), hex castle nut (8), and flatwasher (9) from tie-rod (10) and steering knuckle assembly (6).
3. Separate tie-rod (9) from steering knuckle assembly (6).

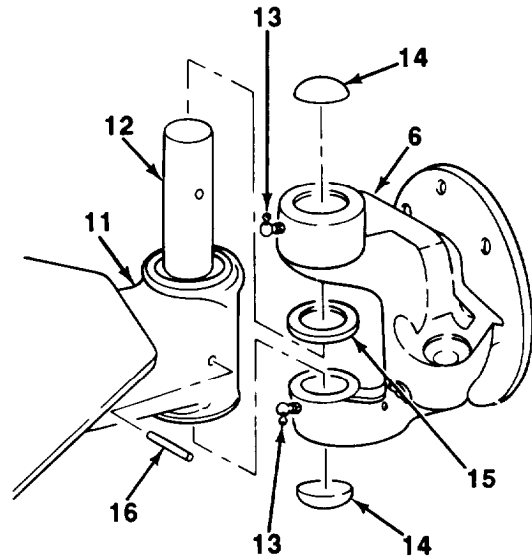


---

**4-54. STEERING KNUCKLE ASSEMBLY REPLACEMENT (Con't).**


---

4. Remove roll pin (16) from front axle assembly (11) and kingpin (12). Discard roll pin.
5. Remove stakes from two welch plugs (14). Remove welch plugs from steering knuckle assembly (6). Discard welch plugs.
6. Remove kingpin (12) steering knuckle assembly (6) and thrustwasher (15) from front axle (11). Discard thrustwasher.
7. Remove two grease fittings (13) from steering knuckle assembly (6). Discard grease fittings.

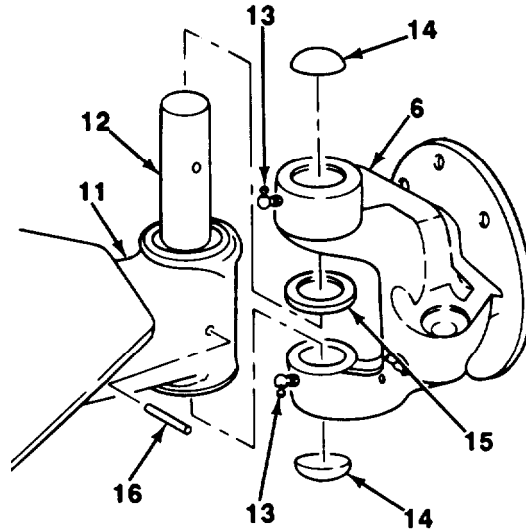

**b. CLEANING AND INSPECTION**


- Dry cleaning solvent, P-D-680, is toxic and flammable. Always wear protective goggles and gloves, and use only in a well-ventilated area. Avoid contact with skin, eyes, and clothes, and DO NOT breathe vapors. DO NOT use near open flame or excessive heat. The solvent's flash point is 100°F-1380°F (3°C-59°C). If you become dizzy while using cleaning solvent, immediately get fresh air and medical help. If solvent contacts eyes, immediately wash your eyes and seek medical attention.
  - Compressed air used for cleaning or drying purposes, or for clearing restrictions, should never exceed 30 psi (207 kPa). Wear protective clothing (goggles/shield, gloves, etc.) and use caution to avoid injury to personnel.
1. Clean all components with dry cleaning solvent and dry with compressed air.
  2. Inspect components for cracks, breaks, burrs, damaged threads, damaged kingpin bushings, or other damage. Replace damaged components.
  3. Check for looseness where shear-proof pin joins steering knuckle and spindle. If looseness is found, replace steering knuckle assembly.

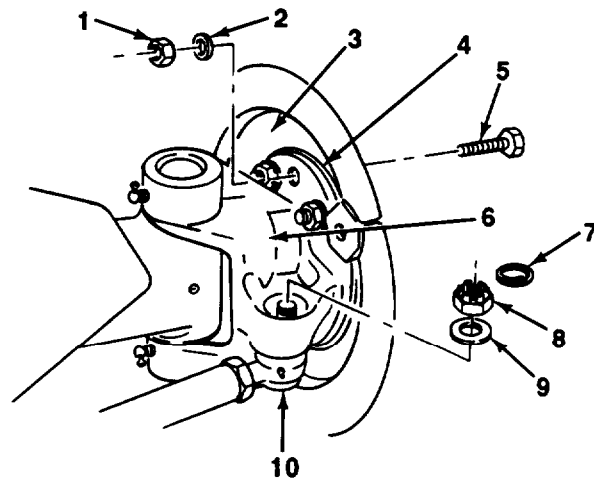
4-54. STEERING KNUCKLE ASSEMBLY REPLACEMENT (Con't).

**C. INSTALLATION**

1. Install new thrustwasher (15) and steering knuckle assembly (6) on front axle (11) with king pin (12).
2. Install new roll pin (16) on front axle (11) and king pin (12).
3. Install two new welch plugs (14) on steering knuckle assembly (6). Flatten each welch plug and stake four places evenly spaced.
4. Install two new grease fittings (13) on steering knuckle assembly (6).



5. Install tie-rod (10) on steering knuckle assembly (6) with flatwasher (9) and hex castle nut (8). Torque hex castle nut to 80-110 lb.-ft. (108-149 N•m). Install circle cotter (7).
6. Install spider assembly (3) with brakeshoes and wedge brake components on spindle (4) with eight capscrews (5) new lockwashers (2), and nuts (1).



**Follow-on Tasks:**

- Connect front dolly air line to airbrake chamber (see paragraph 4-72).
- Install hub and brakedrum (see paragraph 4-75).
- Lubricate steering knuckle assembly (see Lubrication Instructions, Chapter 3, Section I).

---

**4-55. FRONT AXLE ALINEMENT CHECK.**


---

This Task Covers:

Alinement Check

---

Initial Setup:

**Equipment Conditions:**

- Front and rear dollies attached and raised to ride height position (see paragraph 2-10 and 2-11).
- Steering locking pin installed in front axle and steering link to lock steering (see paragraph 2-8)

**Tools/Test Equipment:**

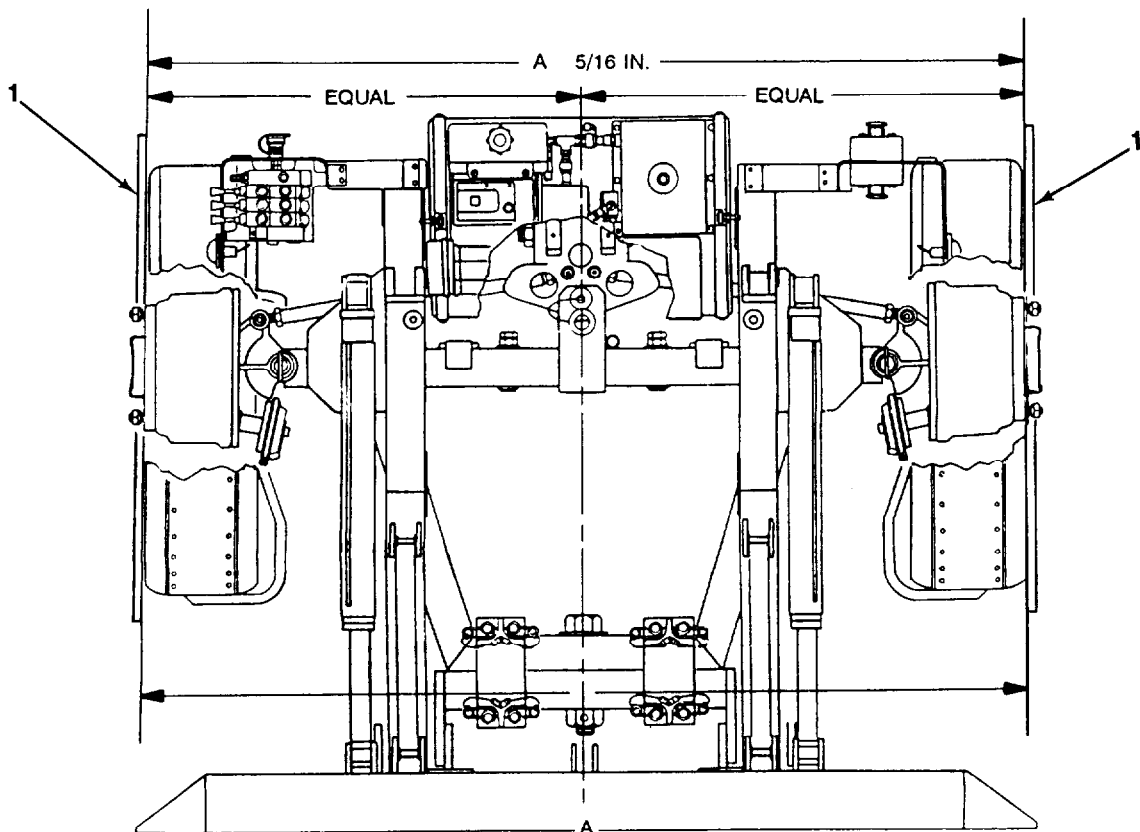
- Two 43 In. (109 cm) or longer straightedges
- Measuring tape (Item 28, Appendix G)

**Personnel Required:** Two

---

**ALINEMENT CHECK**

1. Using two 43 in. (109 cm) or longer straightedges (1) mark each straightedge with three marks:
  - a. Place first mark at center of straightedge.
  - b. Place second mark  $21\frac{1}{2}$  in.  $\pm 1/32$  in. (64.6 cm  $\pm 0.8$  mm) forward of center mark.



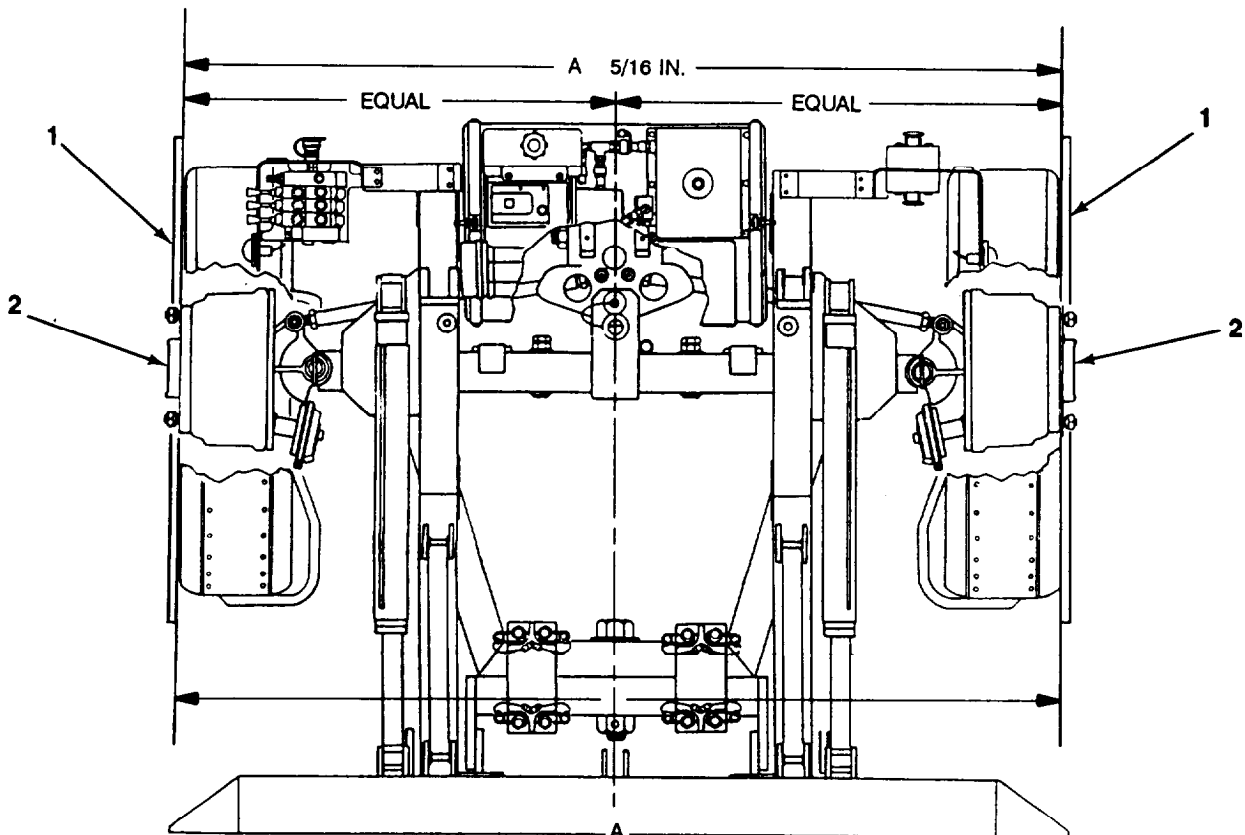
4-55. FRONT AXLE ALINEMENT CHECK (Con't).

- c. Place third mark  $21\frac{1}{2}$  in.  $\pm$   $1/32$  in. (64.6 cm  $\pm$  0.8 mm) rearward of center mark.
2. Position each straightedge (1) against hub face (2) of front axle. Straightedge must be parallel to ground with its center mark placed at axle centerline.
3. Measure and record distance between two rear marks of each straightedge (1). This is dimension "A" of illustration.
4. Measure and record distance between two forward marks of each straightedge (1). Distance between two forward marks should be  $5/16$  in.  $\pm$   $1/16$  in. (7.9 mm  $\pm$  1.6 mm) LESS than dimension "A". This is dimension "A -  $5/16$  in." of illustration.

NOTE

During adjustment, ensure that distances from each straightedge to centerline of front drawbar are equal, as indicated on illustration.

5. If distance between two forward marks of straightedge (1) is out of tolerance, adjustment must be made in tie-rod lengths (see paragraph 4-77).



## Section VIII. BRAKE SYSTEM MAINTENANCE

Paragraph Number	Paragraph Title	Page Number
4-56.	Caging and Uncaging Brakes .....	4-121
4-57.	Brakeshoe Replacement .....	4-124
4-58.	Major Brake Adjustment .....	4-126
4-59.	Minor Brake Adjustment .....	4-130
4-60.	Spider Assembly Replacement .....	4-131
4-61.	Airbrake Chamber Replacement .....	4-136
4-62.	Front Dolly Relay Emergency Valve and Air Reservoir Replacement .....	4-140
4-63.	Front Dolly Booster Relay Valve Replacement .....	4-144
4-64.	Front Dolly Pressure Protection Valve Replacement .....	4-146
4-65.	Airbrake Valve Replacement .....	4-148
4-66.	Rear Dolly Full Function Valve and Air Reservoir Replacement .....	4-152
4-87.	Rear Dolly Booster Relay Valve Replacement .....	4-156
4-68.	Rear Dolly Shutoff Valve and Mounting Bracket Replacement .....	4-158
4-69.	Rear Dolly Parking Brake Valve Replacement .....	4-160
4-70.	Rear Dolly Relay Valve Replacement .....	4-162
4-71.	Pivoting Tray Gladhand Replacement .....	4-164
472.	Front Dolly Air Lines Replacement .....	4-166
4-73.	Rear Dolly Air Lines Replacement .....	4-177
4-74.	Airbrake System Schematics .....	4-188

---

**4-56. CAGING AND UNCAGING BRAKES.**


---

This Task Covers:

- |           |             |
|-----------|-------------|
| a. Caging | b. Uncaging |
|-----------|-------------|
- 

Intitial Setup:

**Equipment Conditions:**

- Wheels chocked.
- Intervehicular air hoses disconnected (see paragraph 2-7).
- Air reservoir drained (see paragraph 3-6).

**Tools/Test Equipment:**

- General mechanic's tool kit (Item 30, Appendix G)
-

4-56. CAGING AND UNCAGING BRAKES (Con't).

**WARNING**

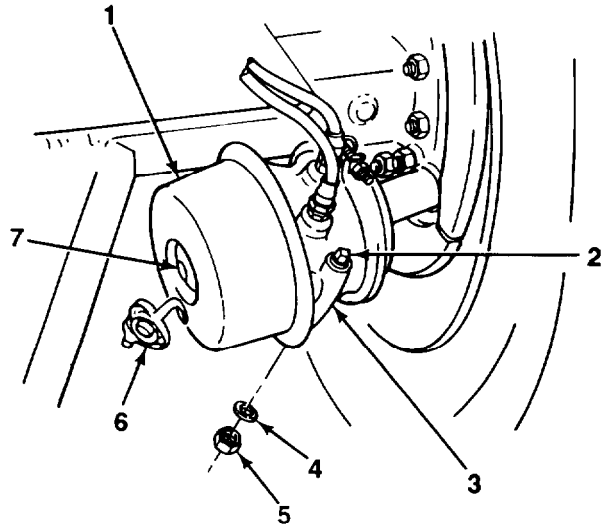
- DO NOT cage spring in “spring” rear dolly airbrake chamber until wheels have been securely chocked. Once rear dolly airbrake chamber spring is caged, dolly set la without emergency/parking brakes and can roll. Failure to chock wheels may result in serious Injury or death to personnel.
- DO NOT attempt to cage brakes if rear dolly airbrake chamber shows any signs of structural damage. Failure to follow this warning may cause forceful release of the spring chamber and its contents, resulting in serious injury or death to personnel.

NOTE

With both the parking and emergency breakaway systems, loss of air pressure causes brakes to apply. Return of air pressure allows brakes to release. Brakes that have been applied due to air pressure loss can be manually released (caged) to allow movement of dolly set or in preparation for maintenance.

**a. CAGING**

1. Remove dust plug (6) from key hole (7) in rear of airbrake chamber (1).
2. Remove nut (5) washer (4) and caging stud (2) from storage slot (3). Install caging stud in key hole (7).
3. Turn caging stud (2) clockwise one-quarter turn. Pull on stud to ensure that stud crosspin is properly seated in pressure plate inside airbrake chamber (1).
4. Install washer (4) and nut (5) fingertight on caging stud (2).





---

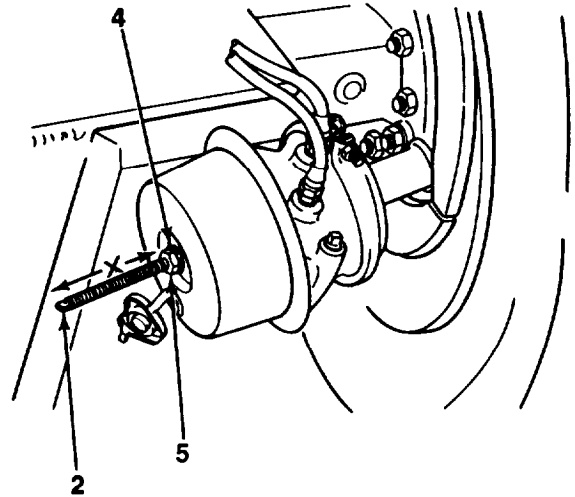
**4-56. CAGING AND UNCAGING BRAKES (Con't).**

---

**CAUTION**

**DO NOT** overtighten nut on caging stud or pressure plate Inside airbrake chamber will be damaged.

5. Tighten nut (5) on caging stud (2) until distance "X" is 3 in. (7.62 cm).

**b. UNCAGING**

1. Remove nut (5) and washer (4) from caging stud (2) to uncage (manually apply) brakes.
2. Remove caging stud (2) from key hole (7).
3. Install caging stud (2) washer (4) and nut (5) in storage slot (3).
4. Install dust plug (6) in key hole (7).

**Follow-on Tasks:**

- Close air reservoir draincock (see paragraph 3-6).
- Connect intervehicular air hoses (see paragraph 2-11).

---

## 4-57. BRAKESHOE REPLACEMENT.

---

This Task Covers:

- a. Removal
  - b. Cleaning and Inspection
  - C. Installation
- 

/nitia/ Setup:

**Equipment Conditions:**

- Hub and brakedrum removed (see paragraph 4-75).

**Materials/Parts:**

- Rags (Item 25, Appendix F)

**Tools/Teat Equipment:**

- General mechanic's tool kit (Item 30, Appendix G)
  - Brake repair pliers (Item 21, Appendix G)
- 

### **a. REMOVAL**

1. turn starwheel (9) at each adjusting bolt (8) clockwise until adjusting plungers are fully retracted in plunger housing (10).
2. Remove two return springs (6) from brakeshoes (1 and 7).

### **CAUTION**

**Use caution not to damage wedge brake components when removing brakeshoes from spider assembly.**

3. Remove brakeshoes (1 and 7) from spider assembly (4).

### **b. CLEANING AND INSPECTION**

1. Clean all parts with rags and a brush.
2. inspect brakeshoes for cracks, looseness of linings or rivets, and wear. If linings are worn flat on wear notch (3) in middle of lining, a thickness equal to or less than 5/16 in. (7.94 mm), replace brakeshoes.

### **NOTE**

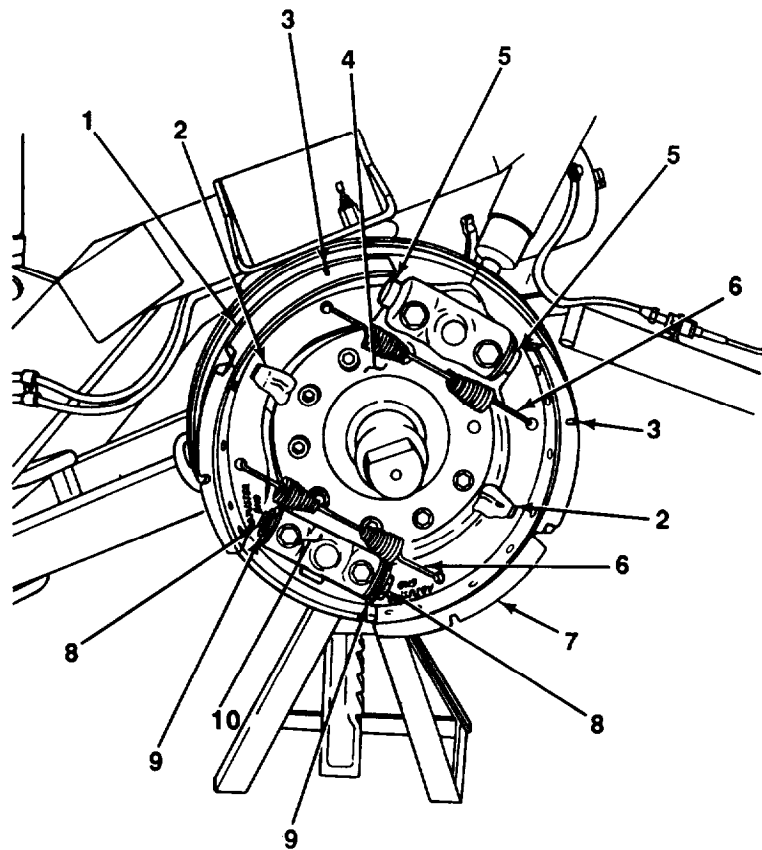
**If brakeshoes are replaced, new return springs MUST be Installed.**

3. Inspect return springs for distortion or other damage.

---

**4-57. BRAKESHOE REPLACEMENT (Con't).**


---



<b>C. INSTALLATION</b>
------------------------

**CAUTION**

Use caution not to damage wedge brake components when installing brakeshoes on spider assembly.

1. Install brakeshoes (1 and 7) on spider assembly (4) with ends stamped ADJUSTER END on adjusting bolt (8) side of spider.
2. Secure brakeshoes (1 and 7) under hold-down clips (2).
3. Engage grooves in anchor buttons (5) and adjusting bolts (8) in brakeshoe webs.
4. Install two return springs (6) on brakeshoes (1 and 7).

Follow-on Tasks:

- Install hub and brakedrum (see paragraph 4-75).
- Perform major brake adjustment (see paragraph 4-58).

---

## 4-58. MAJOR BRAKE ADJUSTMENT.

---

This Task Covers: Adjustment

---

Initial Setup:

**Equipment Conditions:**

- Wheels chocked.
- Hubs and brakedrums installed (see paragraph 4-75).
- Brakes caged (see paragraph 4-56).

**Tools/Teat Equipment:**

- General mechanic's tool kit (Item 30, Appendix G)
- Compressor unit (Item 4, Appendix G)
- Torque wrench, 0-175 lb.-ft. (Item 42, Appendix G)

**Materials/Parts:**

- Dry cleaning solvent (Item 27, Appendix F)

**General Safety instructions:**

- Dry cleaning solvent is flammable and must not be used near an open flame. Use only in a well-ventilated area.

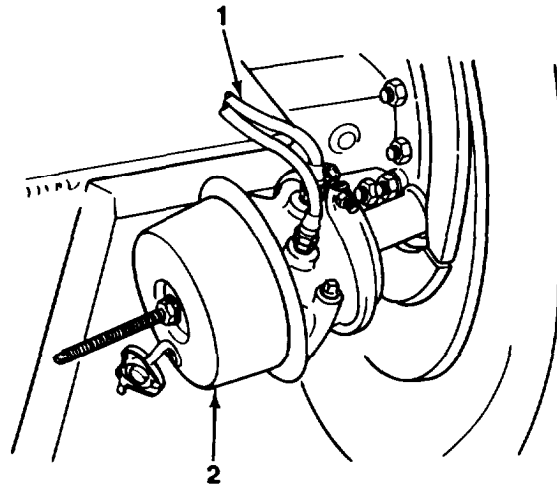
---

**NOTE**

- Perform this adjustment procedure after initial inatallation of brakeshoes to ensure that brakeshoes are centered In brakedrum and have correct brakeshoe lining-to-brakedrum clearance.
- Front and rear dolly brakes are adjusted the same way. Rear dolly brakes are Illustrated.

## ADJUSTMENT

1. Remove bottom rubber vent plug from nonpressure portion of each airbrake chamber (2). Connect a temporary air hose (1) to airbrake chamber.

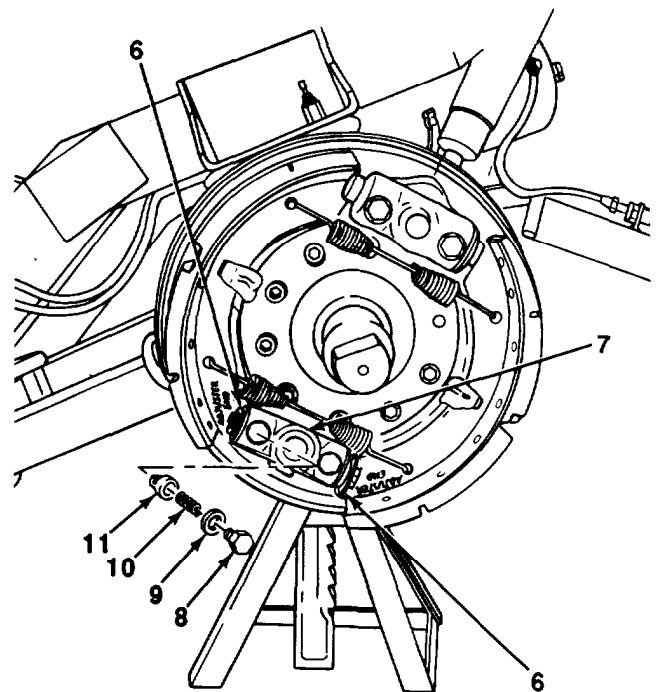
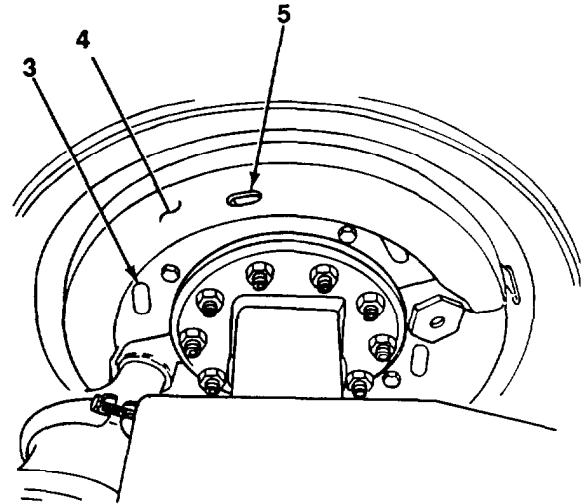


---

**4-58. MAJOR BRAKE ADJUSTMENT (Con't).**


---

2. Remove plugs from access slots (3). Check adjusting bolts to ensure they are completely bottomed. If not, manually back off starwheel (6) by turning counter clockwise to bottomed position.
3. Using 15-20 psi (103-138 kPa) air, pulsate air pressure to actuate and release brakes five or six times and observe through access slots that starwheel and adjusting bolt for each brakeshoe are rotating.
4. Insert feeler gage into access slot (5) in top and bottom dust shields (4). Check brakeshoe lining-to-brakedrum clearance at top of each brakeshoe. Total clearance for both brakeshoes should not exceed 0.090 in. (2.3 mm). Individual brakeshoe clearance should not exceed 0.050 in. (1.3 mm) across width of shoe.
  - (a) If clearances are within specification, install plugs in access slots (3). Remove temporary air hose (1) from airbrake chamber (2). Proceed to step 5.
  - (b) If clearances are not within specification, proceed to step 5.
5. Rotate brakedrum by hand one full turn. There should be minimal drag. If drag is apparent, proceed to step 6.
6. If brakeshoes have not properly adjusted, remove hub and brakedrum (see paragraph 4-75).
7. Remove two guide pawl hollow capscrews (8) copper washers (9), springs (10), and adjusting pawls (11) from plunger housing (7).
8. Inspect teeth of adjusting pawls (11) for rounded or flattened condition. If teeth are damaged, replace spider assembly (see paragraph 4-60).

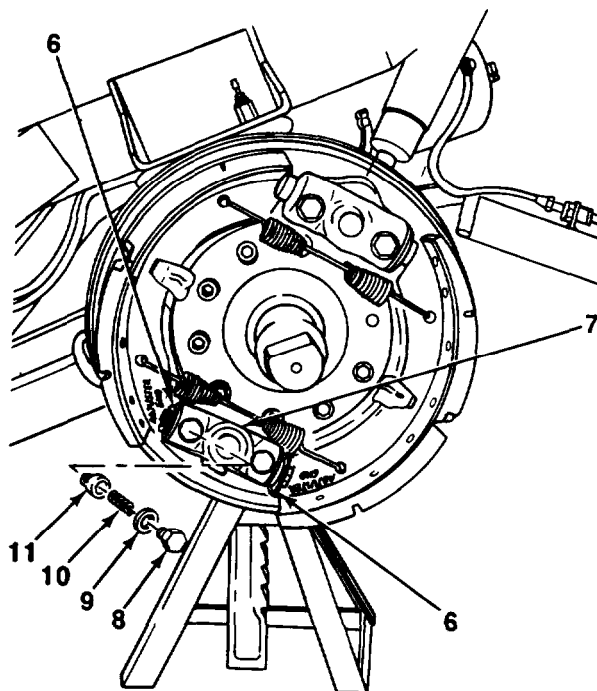


4-58. MAJOR BRAKE ADJUSTMENT (Con't).



Dry cleaning solvent, P-D-680, is toxic and flammable. Always wear protective goggles and gloves, and use only in a well-ventilated area. Avoid contact with skin, eyes, and clothes, and DO NOT breathe vapors. DO NOT use near open flame or excessive heat. The solvent's flash point is 100°F-138°F (38°C-59°C). If you become dizzy while using cleaning solvent, Immediately get fresh air and medical help. If solvent contacts eyes, immediately wash your eyes and seek medical attention.

9. inspect bores of adjusting pawls (11) for contamination. If contaminated, clean with dry cleaning solvent and thoroughly air dry.
10. Install two adjusting pawls (11), springs (10), copper washers (9), and guide pawl hollow cap-screws (8) in plunger housing (7). Torque cap-screws to 15-20 lb.-ft. (20-27 N•m).
11. Manually back off each starwheel (6) to bottom position.
12. Install hub and brakedrum (see paragraph 4-75).
13. Repeat steps 2 through 5.

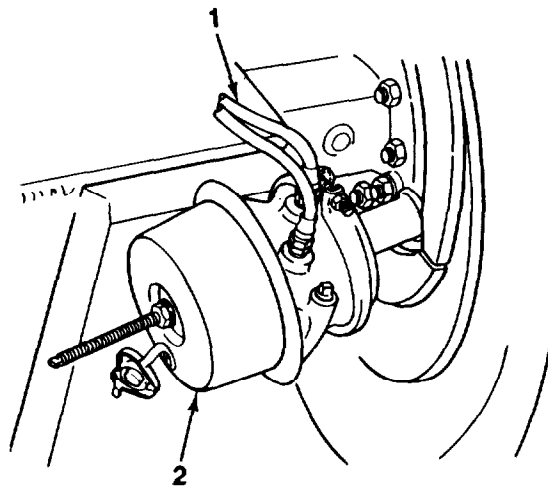


---

**4-58. MAJOR BRAKE ADJUSTMENT (Con't).**

---

14. Remove temporary air hose (1) from airbrake chamber (2).



Follow-on Tasks:

- Uncage brakes (see paragraph 4-56).

---

## 4-59. MINOR BRAKE ADJUSTMENT.

---

This Task Covers: Adjustment

---

Initial Setup:

Tools/Test Equipment:

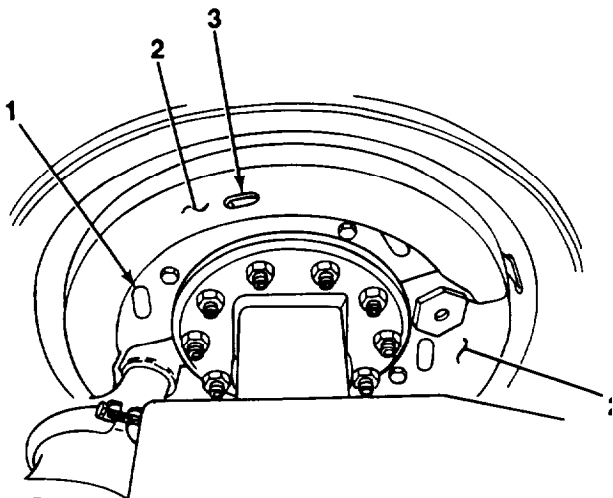
- General mechanic's tool kit (Item 30, Appendix G)
  - Hydraulic jack, 12 ton (Item 17, Appendix G)
  - Trestle (Item 32, Appendix G)
- 

### NOTE

Dolly set hydraulic lifting system may be used Instead of a hydraulic jack to raise dolly set wheels off ground (see paragraph 2-21).

### ADJUSTMENT

1. Chock wheel on side not being adjusted.
2. Raise dolly set on side to be adjusted until wheel is off ground. Support dolly set in raised position with trestle.
3. Insert feeler gage into access slots (3) in top and bottom dust shields (2). Check brakeshoe lining-to-brakedrum clearance at top of each brakeshoe. Total clearance for both brakeshoes should not exceed 0.090 in. (2.3 mm). Individual brakeshoe clearance should not exceed 0.050 in. (1.3 mm) across width of shoe.
4. If clearances measured in step 3 are as specified, brakes are properly adjusted. If clearances are not within specification, proceed to step 5.
5. Remove plug from access slot (1). Insert long, thin screwdriver into access slot until it contacts starwheel on adjusting bolt. Turn starwheel counterclockwise to reduce clearance or clockwise to increase clearance.
6. Repeat step 3. If clearance is within specification, install plug in access slot (1).
7. Repeat steps 5 and 6 to adjust for correct clearance on other brakeshoe on same wheel.
8. Rotate brakedrum one full turn by hand. If drag is apparent, repeat steps 5 through 7.
9. Repeat steps 1 through 7 for other wheels.
10. Remove trestle and lower dolly set wheel to ground.





---

## 4-60. SPIDER ASSEMBLY REPLACEMENT.

---

This Task Covers:

- |  |   |
|--|---|
| <ul style="list-style-type: none"> <li>a. Removal</li> <li>b. Cleaning and Inspection</li> </ul> | <ul style="list-style-type: none"> <li>c. Installation</li> </ul> |
|--|---|
- 

Initial Setup:

### Equipment Conditions:

- Air lines disconnected from airbrake chamber (see paragraph 4-72 or 4-73).
- Brakes caged (rear dolly) (see paragraph 4-56).
- Hub and brakedrum removed (see paragraph 4-75).
- Brakeshoes removed (see paragraph 4-57).

### Tools/Test Equipment:

- General mechanic's tool kit (Item 30, Appendix G)
- Compressor unit (Item 4, Appendix G)

### Materials/Parts:

- Wire brush (Item 4, Appendix F)
- Silicone compound (Item 12, Appendix F)
- Detergent (Item 13, Appendix F)
- Grease (Item 19, Appendix F)
- Rags (Item 25, Appendix F)
- Dry cleaning solvent (Item 27, Appendix F)
- Fourteen lockwashers

### General Safety Instructions:

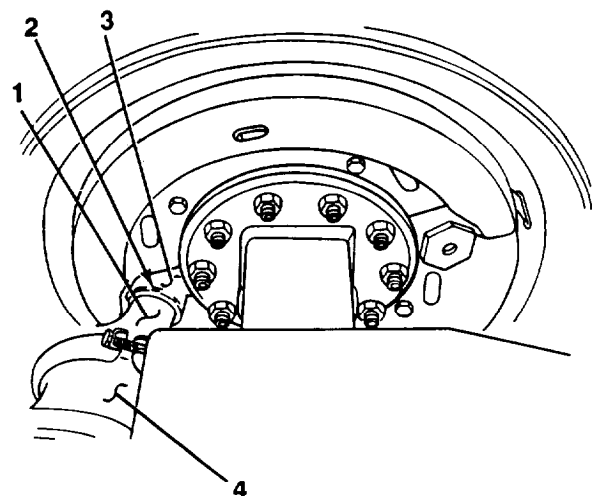
- Dry cleaning solvent is flammable and must not be used near an open flame. Use only in a well-ventilated area.
  - Compressed air used for cleaning purposes should never exceed 30 psi (207 kPa).
- 

### NOTE

Front and rear dolly spider assemblies are replaced the same way. Rear dolly spider assembly is illustrated.

#### a. REMOVAL

1. Loosen spanner nut (2) on housing assembly tube (1) of airbrake chamber (4).
2. Remove airbrake chamber (4) from plunger housing (3).



---

**4-60. SPIDER ASSEMBLY REPLACEMENT (Con't).**

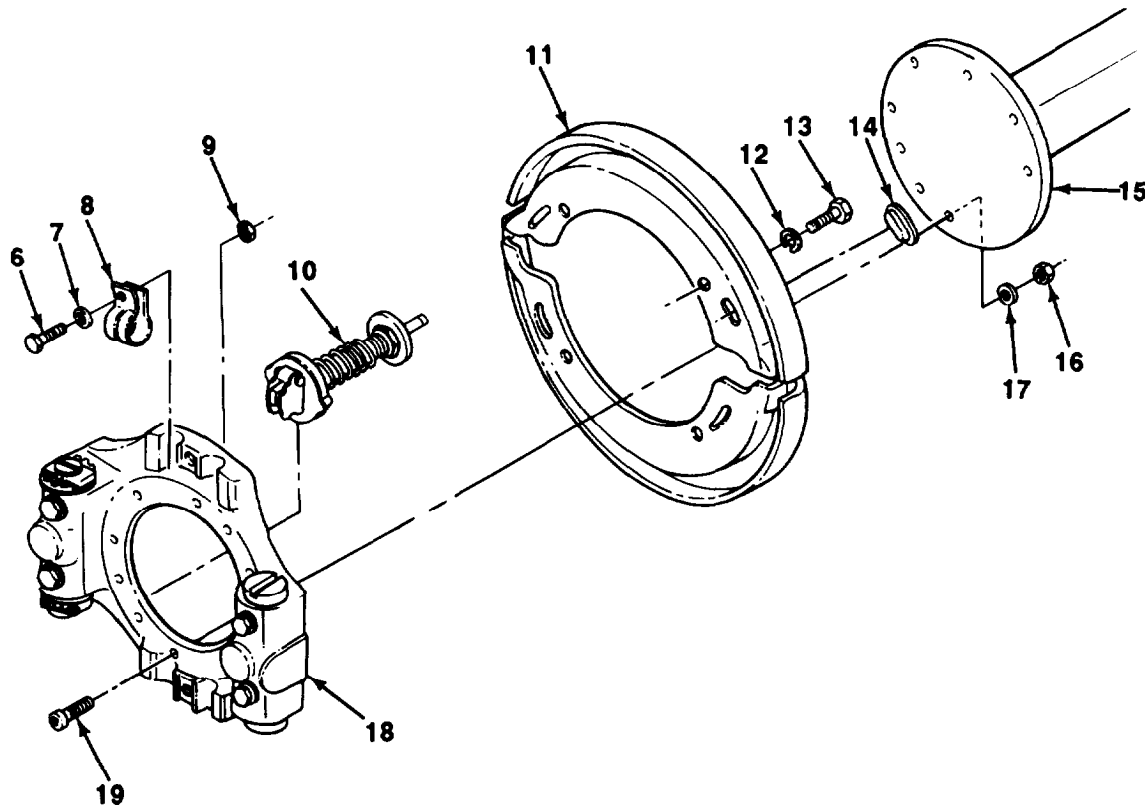
---

3. Remove wedge assembly (10) by pulling it straight out of plunger housing (3).
4. Remove four capscrews (13), lockwashers (12), and two dust shields (11) from spider (18). Discard lockwashers.

**NOTE**

On front dolly, spider is mounted to steering knuckle spindle.

5. Remove eight nuts (16), lockwashers (17), sockethead capscrews (10), and spider (18) from axle spindle (15). Discard lockwashers.
6. Remove four plugs (14) from two dust shields (11).
7. Remove two nuts (9), bolts (6), lockwashers (7), and hold-down clips (8) from spider (18). Discard lockwashers.



---

**4-60. SPIDER ASSEMBLY REPLACEMENT (Con't).**

---

---

**b. CLEANING AND INSPECTION**

---



- Dry cleaning solvent, P-D-680, is toxic and flammable. Always wear protective goggles and gloves, and use only in a well-ventilated area. Avoid contact with skin, eyes, and clothes, and DO NOT breathe vapors. DO NOT use near open flame or excessive heat. The solvent's flash point is 100°F-138°F (38°C-59°C). If you become dizzy while using cleaning solvent, immediately get fresh air and medical help. If solvent contacts eyes, immediately wash your eyes and seek medical attention.
  - Compressed air used for cleaning or drying purposes, or for clearing restrictions, should never exceed 30 psi (207 kPa). Wear protective clothing (goggles/shield, gloves, etc.) and use caution to avoid injury to personnel.
1. Clean spider with dry cleaning solvent. Use a wire brush as required to remove dirt and corrosion. Dry thoroughly with compressed air.
  2. Clean silicone compound from housing assembly tube with a rag dipped in dry cleaning solvent.
  3. Clean wedge assembly with detergent and water, and dry with compressed air.
  4. Inspect spider for hairline cracks or other damage. Replace damaged spider.
  5. Inspect airbrake chamber and spanner nut for damage. Replace damaged spanner nut and airbrake chamber.
  6. Inspect wedge assembly for damaged rubber boot or broken spring. Inspect stem ramp and rollers for flat spotting and pitting. Replace damaged wedge assembly.
  7. Inspect area of wedge assembly cage which retains rollers. Rollers must be held in cage and allowed to turn freely. If rollers do not turn freely, replace wedge assembly.

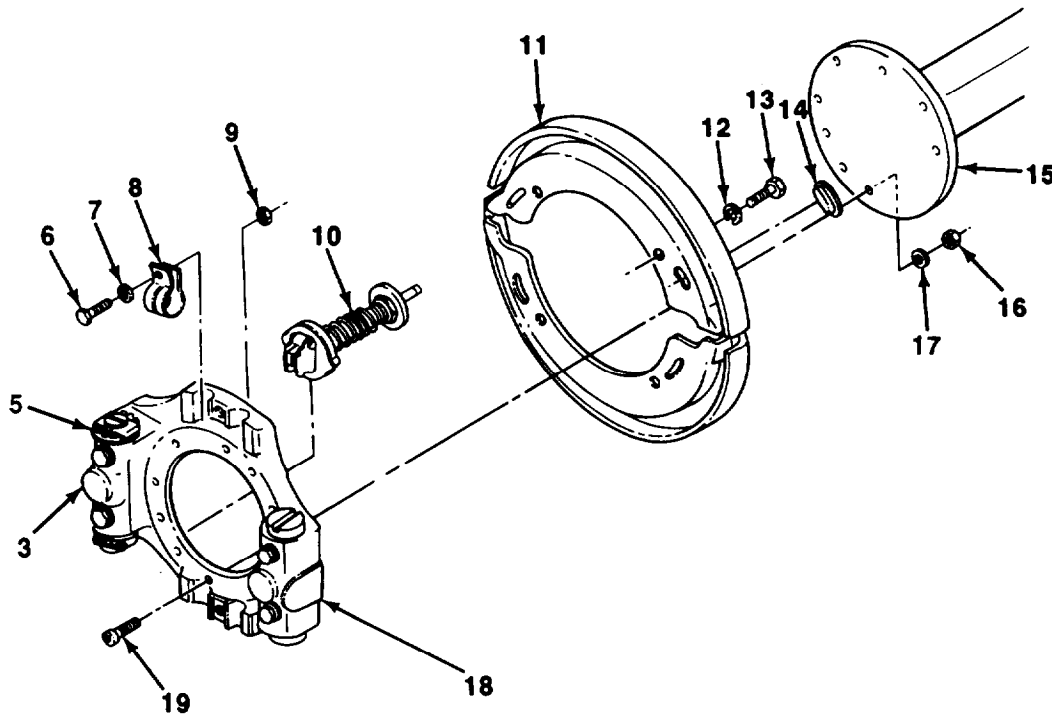
4-60. SPIDER ASSEMBLY REPLACEMENT (Con't).

**c. INSTALLATION**

**NOTE**

On front dolly, spider is mounted to steering knuckle spindle.

1. install spider (18) on axle spindle (15) with eight sockethead capscrews (19), new lockwashers (17), and nuts (16).
2. Install two hold-down clips (8) on top and bottom of spider (18) with two new lockwashers (7), bolts (6), and nuts (9).
3. Install two dust shields (11) on spider (18) with four new lockwashers (12) and capscrews (13).



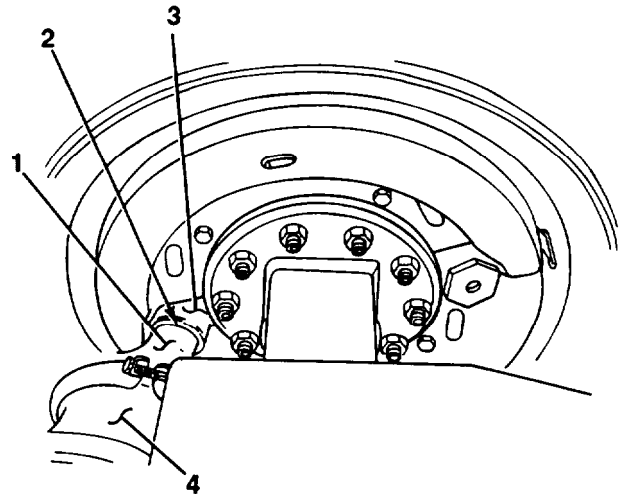
4. Install four plugs (14) on two dustshields (11).
5. Fill cavity inside plunger housing (3) with grease to a level just below the airbrake chamber seat.
6. Aline tabs of wedge assembly (10) with keyway slots in plunger housing (3). Install wedge assembly and push In to seat. Ensure that wedge assembly moves starwheels (5) when applied.

---

**4-60. SPIDER ASSEMBLY REPLACEMENT (Con't).**

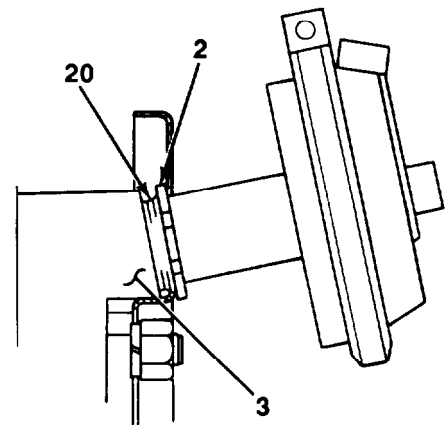

---

7. Thread spanner nut (2) onto housing assembly tube (1). DO NOT tighten spanner nut.
8. Apply silicone compound to first three threads of housing assembly tube (1).
9. Install airbrake chamber (4) on plunger housing (3) until it bottoms.

**NOTE**

If after seating spanner nut, more than top two threads of spanner nut are visible, spider must be replaced.

10. Tighten spanner nut (2). Ensure that threads (20) on tapered side of spanner nut seat in chamfered area of plunger housing (3).

**Follow-on Tasks:**

- Install brakeshoes (see paragraph 4-57).
- Install hub and brakedrum (see paragraph 4-75).
- Connect air lines to airbrake chamber (see paragraph 4-72 or 4-73).
- Perform major brake adjustment (see paragraph 4-58).
- Uncage brakes (rear dolly) (see paragraph 4-56).

---

## 4-61. AIRBRAKE CHAMBER REPLACEMENT.

---

This Task Covers:

- a. Removal
  - b. Cleaning and Inspection
  - C. Installation
- 

Initial/ Setup:

**Equipment Conditions:**

- Wheels chocked.
- Air reservoir drained (see paragraph 3-6).
- Brakes caged (rear dolly)(see paragraph 4-56).

**Tools/Test Equipment:**

- General mechanic's tool kit (Item 30, Appendix G)

**Materials/Parts:**

- Silicone compound (Item 12, Appendix F)
- Rags (Item 25, Appendix F)
- Dry cleaning solvent (Item 27, Appendix F)
- Marker tags (Item 28, Appendix F)
- Antiseize tape (Item 29, Appendix F)

**General Safety Instructions:**

- Dry cleaning solvent is flammable and must not be used near an open flame. Use only in a well-ventilated area.
- 

**WARNING**

DO NOT attempt to repair airbrake chambers. Rear dolly airbrake chamber is under spring tension. Serious injury or death to personnel may result if disassembly is attempted.

**NOTE**

- Front dolly airbrake chamber and rear dolly airbrake chamber are replaced the same way except the front dolly airbrake chamber has one hose assembly and a plug; the rear dolly airbrake chamber has two hose assemblies.
- All air lines should be tagged before removal. Refer to paragraph 4-18 for tagging Instructions.

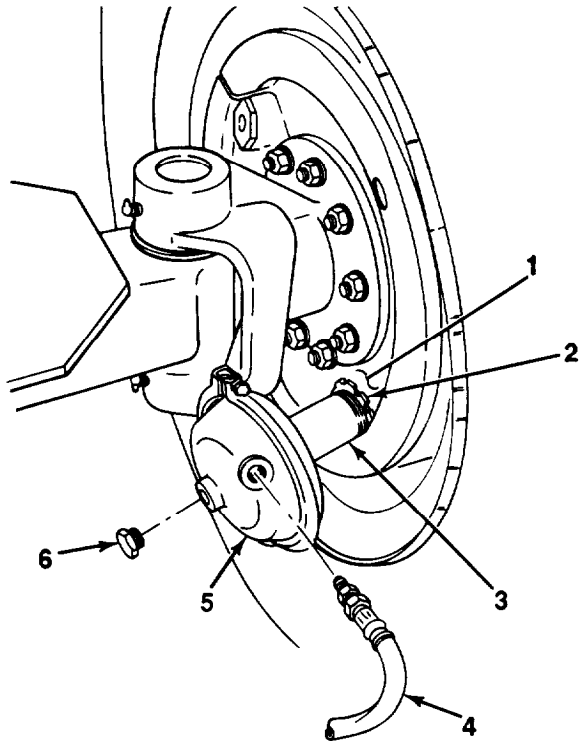
**a. REMOVAL**

1. Disconnect one or two hose assemblies (4) from airbrake chamber (5 or 7).
2. Loosen spanner nut (2) on housing assembly tube (3).
3. Remove airbrake chamber (5 or 7) from plunger housing (1).
4. If removing a front dolly airbrake chamber (5), remove plug (6).

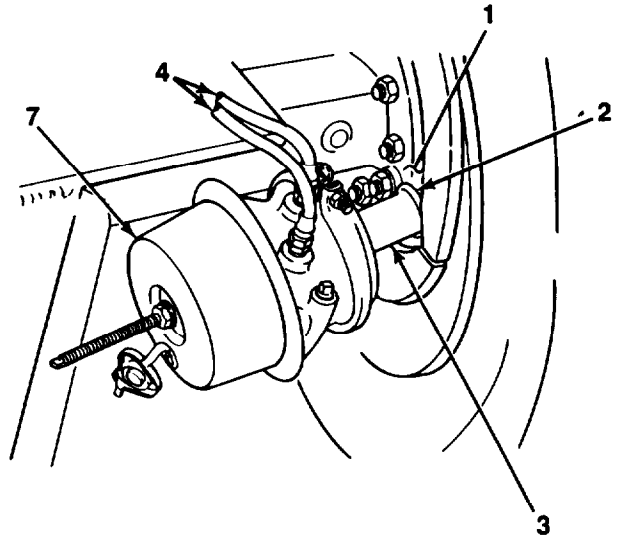
---

**4-61. AIRBRAKE CHAMBER REPLACEMENT (Con't).**


---



FRONT DOLLY AIRBRAKE CHAMBER



REAR DOLLY AIRBRAKE CHAMBER

**b. CLEANING AND INSPECTION**

**WARNING**


Dry cleaning solvent, P-D-680, is toxic and flammable. Always wear protective goggles and gloves, and use only in a well-ventilated area. Avoid contact with skin, eyes, and clothes, and **DO NOT** breathe vapors. **DO NOT** use near open flame or excessive heat. The solvent's flash point is 100°F-138°F (36°C-59°C). If you become dizzy while using cleaning solvent, immediately get fresh air and medical help. If solvent contacts eyes, immediately wash your eyes and seek medical attention.

1. Clean silicone compound from housing assembly tube with a rag dipped in dry cleaning solvent.
2. Inspect airbrake chamber and spanner nut for damage. Replace damaged spanner nut and airbrake chamber.
3. Remove, clean, and inspect wedge assembly inside plunger housing as required (see paragraph 4-60).

---

**4-61. AIRBRAKE CHAMBER REPLACEMENT (Con't).**

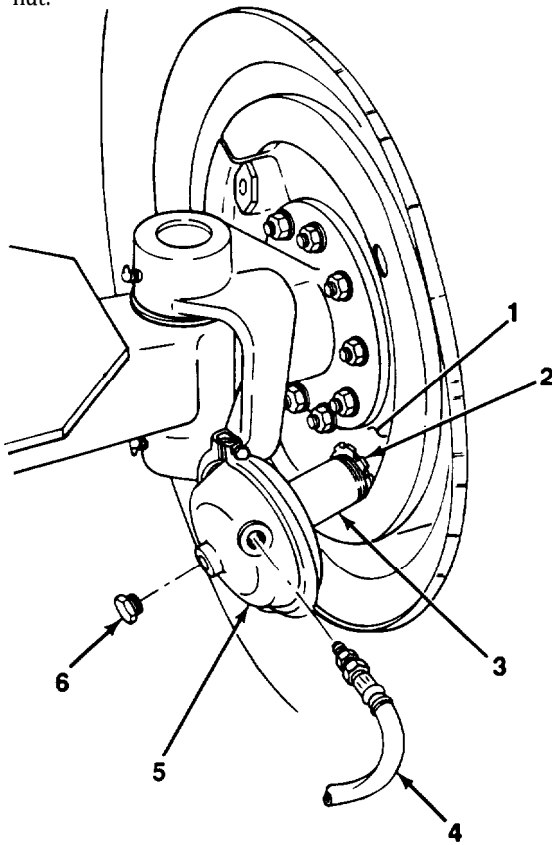
---

**C. INSTALLATION**

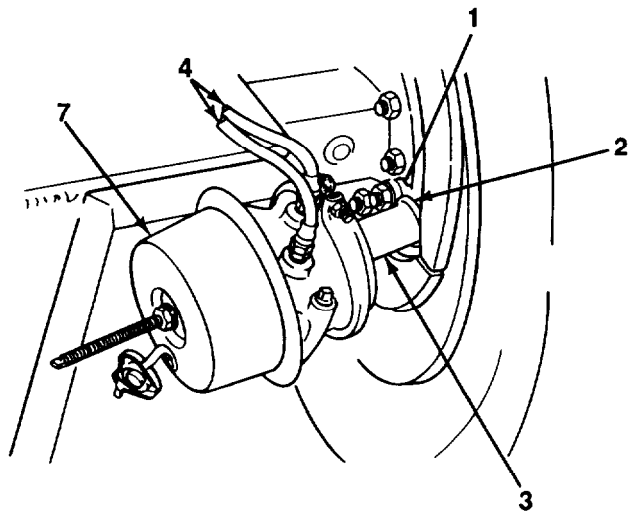
**NOTE**

**Male threads of fittings should be coated with antiseize tape if not already factory-coated with an antiseize compound.**

1. If a front dolly airbrake chamber (5) was removed, install plug (6).
2. If removed, install wedge in plunger housing (1). Ensure that wedge assembly is properly seated (see paragraph 4-60).
3. Thread spanner nut (2) onto housing assembly tube (3) of air-brake chamber (5 or 7). **DO NOT** tighten spanner nut.



**FRONT DOLLY AIRBRAKE CHAMBER**



**REAR DOLLY AIRBRAKE CHAMBER**



---

**4-61. AIRBRAKE CHAMBER REPLACEMENT (Con't).**

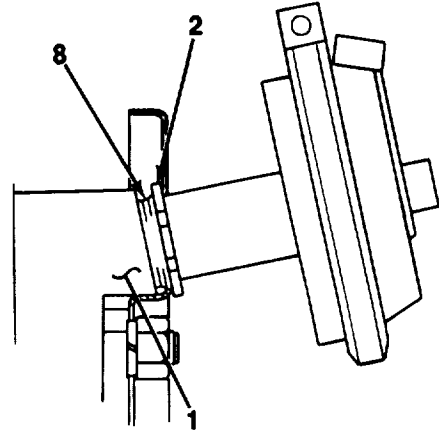
---

4. Apply silicone compound to first three threads of housing assembly tube (3).
5. Install airbrake chamber (5 or 7) on plunger housing (1) until it bottoms.

**NOTE**

**If after seating spanner nut, more than top two threads of spanner nut are visible, spider must be replaced (see paragraph 4-60).**

6. Tighten spanner nut (2). Ensure that threads (8) on tapered side of spanner nut seat in chamfered area of plunger housing (1).
7. Connect one or two hose assemblies (4) to airbrake chamber (5 or 7).

**Follow-on Tasks:**

- Uncage brakes (rear doily) (see paragraph 4-56).
- Close air reservoir draincock (see paragraph 3-6).
- Connect Intervehicular air hoses (see paragraph 2-11).
- Check for leaks (see paragraph 4-23).

---

**4-62. FRONT DOLLY RELAY EMERGENCY VALVE AND AIR RESERVOIR REPLACEMENT.**

---

This Task Covers:

- a. Removal b. Installation
- 

Initial Setup:

Equipment Conditions:

- Wheels chocked.
- Air reservoir drained (see paragraph 3-6).
- Front dolly booster relay valve removed (see paragraph 4-63).
- Front dolly pressure protection valve removed (see paragraph 4-64).

Materials/Parts:

- Sealing compound (Item 9, Appendix F)
- Marker tags (Item 28, Appendix F)
- Antiseize tape (Item 29, Appendix F)
- Four locknuts

Personnel Required: Two

Tools/Test Equipment:

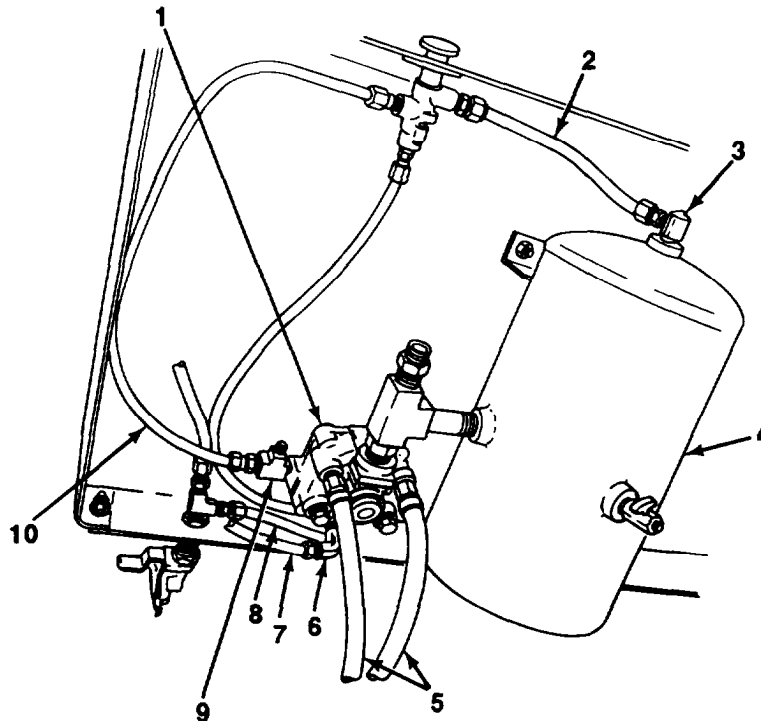
- General mechanic's tool kit (Item 30, Appendix G)
- 

**a. REMOVAL**

**NOTE**

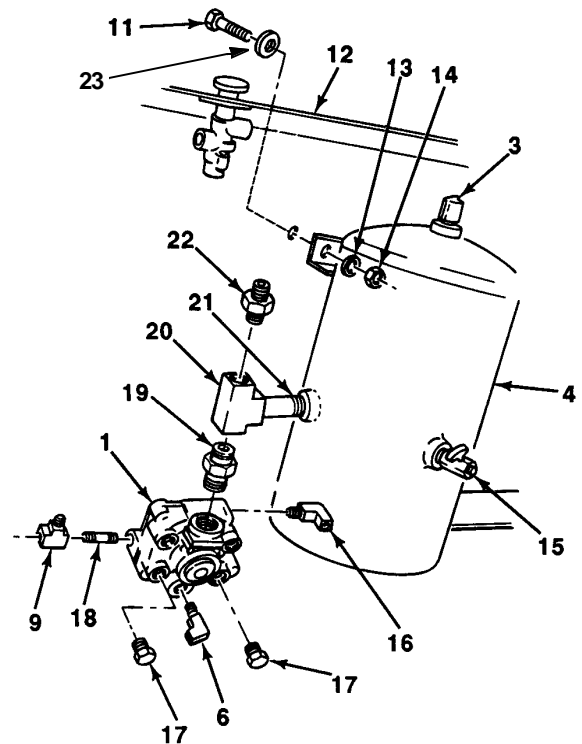
All air lines should be tagged before removal. Refer to paragraph 4-18 for tagging Instructions.

1. Disconnect two hose assemblies (5) from underside of relay emergency valve (1).



## 4-62. FRONT DOLLY RELAY EMERGENCY VALVE AND AIR RESERVOIR REPLACEMENT (Con't).

2. Disconnect tube assembly (7) from elbow (6).
3. Disconnect tube assembly (8) from elbow (16) at top of relay emergency valve (1).
4. Disconnect tube assembly (2) from elbow (3).
5. Disconnect tube assembly (10) from tee (9).
6. Remove four locknuts (14), flatwashers (13), three capscrews (11), four flatwashers (23) and air reservoir (4) with relay emergency valve (1) from pivoting tray (12). Discard locknuts.
7. Remove relay emergency valve (1) with hex pipe nipple (19) from tee (20).
8. Remove tee (20) and nipple (21) from air reservoir (4). Remove reducer (22) from tee.
9. Remove elbows (6 and 16), tee (9), nipple (18), hex pipe nipple (19), and two plugs (17) from relay emergency valve (1).
10. Remove elbow (3) and draincock (15) from air reservoir (4).



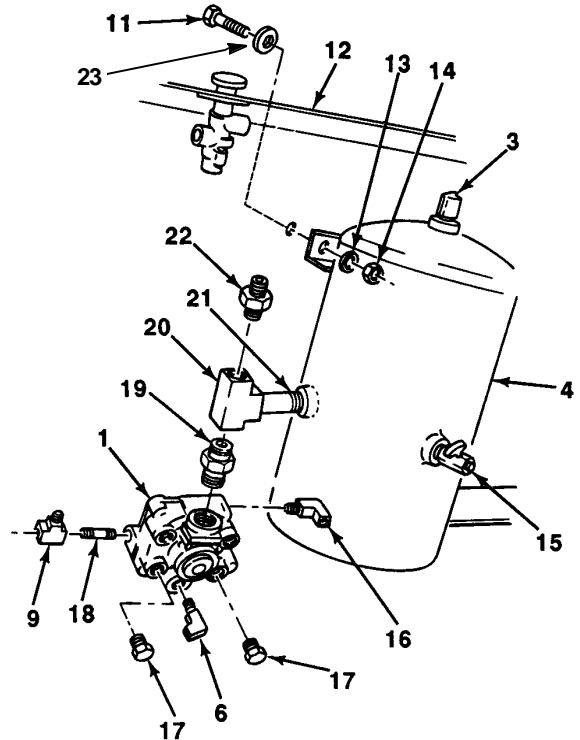
**4-62. FRONT DOLLY RELAY EMERGENCY VALVE AND AIR RESERVOIR REPLACEMENT (Con't).**

**b. INSTALLATION**

**NOTE**

**Male threads of fittings should be coated with antiseize tape if not already factory-coated with an antiseize compound.**

1. Install elbow (3) and draincock (15) on air reservoir (4).
2. Install elbows (6 and 16), nipple (18), tee (9), and two plugs (17) on relay emergency valve (1).
3. Apply sealing compound to threads of hex pipe nipple (19). Install hex pipe nipple on relay emergency valve (1).
4. Install reducer (22) on tee (20).
5. Install nipple (21) and tee (20) on air reservoir (4).
6. Install hex pipe nipple (19) and relay emergency valve (1) on tee (20).
7. Install air reservoir (4) with relay emergency valve (1) on pivoting tray (12) with three cap-screws (11), eight flatwashers (13 and 23), and four new locknuts (14).

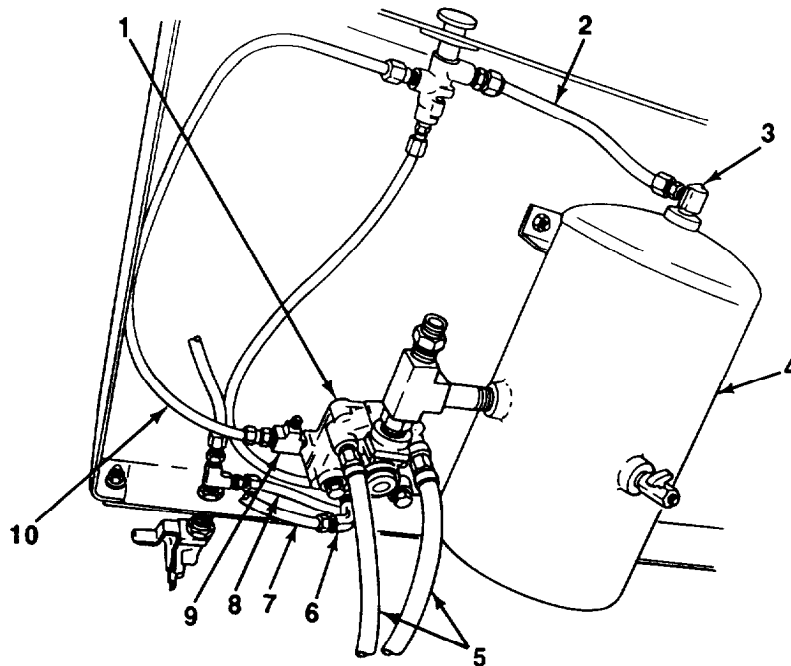


---

**4-62. FRONT DOLLY RELAY EMERGENCY VALVE AND AIR RESERVOIR REPLACEMENT (Con't).**

---

8. Connect tube assembly (10) to tee (9) .
9. Connect tube assembly (2) to elbow (3).
10. Connect tube assembly (8) to elbow (16) at top of relay emergency valve (1).
11. Connect tube assembly (7) to elbow (6).
12. Connect two hose assemblies (5) to relay emergency valve (1).

**Follow-on Tasks:**

- Install front dolly pressure protection valve (see paragraph 4-64).
- Install front dolly booster relay valve (see paragraph 4-63).
- Close air reservoir draincock (see paragraph 3-6).
- Connect intervehicular air hoses (see paragraph 2-11).
- Check for leaks (see paragraph 4-23).

---

## 4-63. FRONT DOLLY BOOSTER RELAY VALVE REPLACEMENT,

---

This Task Covers:

- a. Removal b. Installation
- 

initial Setup:

**Equipment Conditions:**

- Wheels chocked.
- Air reservoir drained (see paragraph 3-6)

**Materials/Parts:**

- Marker tags (Item 28, Appendix F)
- Antiseize tape (Item 29, Appendix F)

**Tools/Test Equipment:**

General mechanic's tool kit (Item 30, Appendix G)

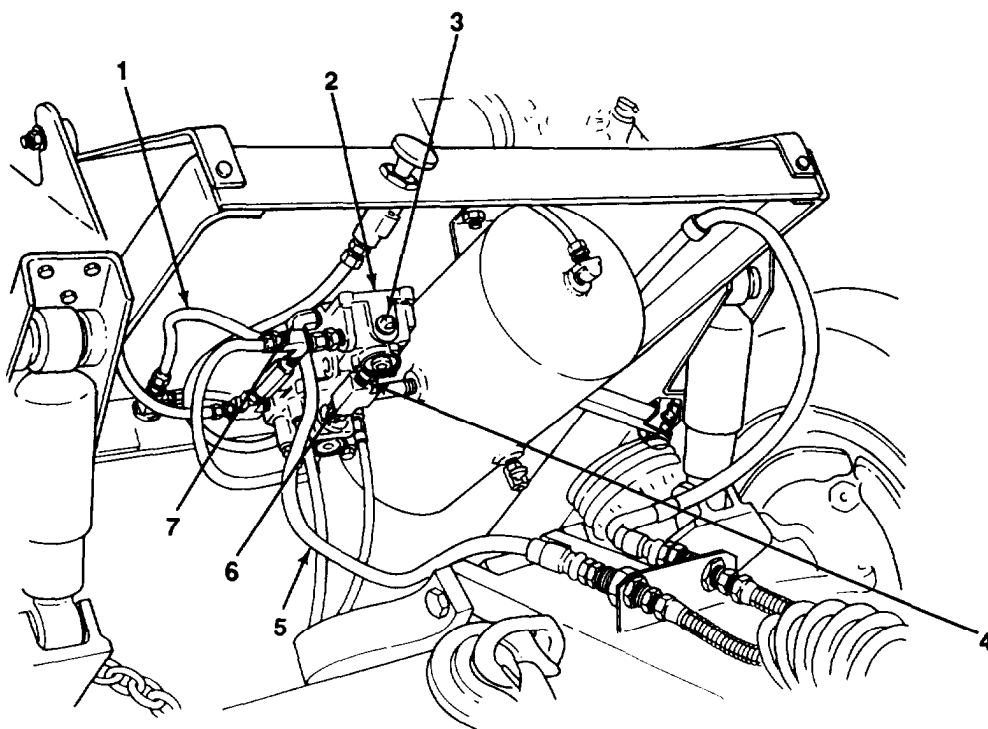
---

**a. REMOVAL**

**NOTE**

All air lines should be tagged before removal. Refer to paragraph 4-18 for tagging Instructions.

1. Disconnect Intervehicular air hose (5) from elbow (7).
2. Disconnect tube assembly (1) from booster relay valve (2).



---

**4-63. FRONT DOLLY BOOSTER RELAY VALVE REPLACEMENT (Con't).**

---

3. Remove booster relay valve (2) from reducer (4).
4. If damaged, remove reducer (4) from tee (6).
5. Remove two plugs (3) and elbow (7) from booster relay valve (2).

**b. INSTALLATION**

## NOTE

Male threads of fittings should be coated with antiseize tape if not already factory-coated with an antiseize compound.

1. Install elbow (7) and two plugs (3) on booster relay valve (2).
2. If removed, install reducer (4) on tee (6).
3. Install booster relay valve (2) on reducer (4).
4. Connect tube assembly (1) to booster relay valve (2).
5. Connect intervehicular air hose (5) to elbow (7).

Follow-on Tasks:

- Close air reservoir draincock (see paragraph 3-6).
- Connect intervehicular air hoses (see paragraph 2-11).
- Check for leaks (see paragraph 4-23).

---

## 4-64. FRONT DOLLY PRESSURE PROTECTION VALVE REPLACEMENT

---

This Task Covers:

- a. Removal
  - b. Installation
- 

Initial Setup:

Equipment Conditions:

- Wheels chocked.
- Air reservoir drained (see paragraph 3-6).

Materials/Parts:

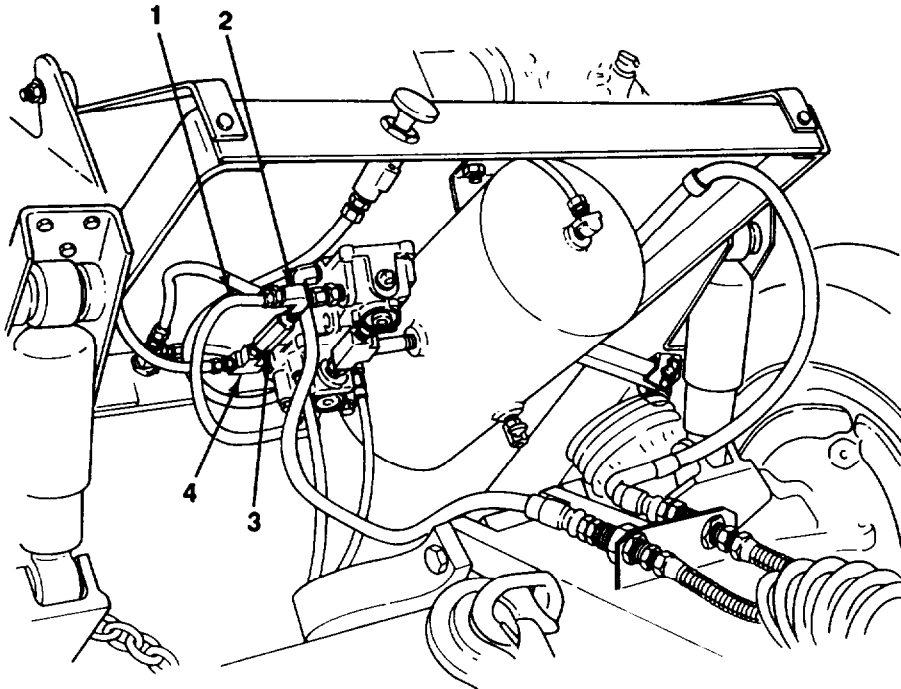
- Antiseize tape (Item 29, Appendix F)

Tools/Test Equipment:

- General mechanic's tool kit (Item 30, Appendix G)
- 

### a. REMOVAL

1. Disconnect tube assembly (1) from elbow (2).
2. Remove pressure protection valve (3) with elbow (2) from tee (4).
3. Remove elbow (2) from pressure protection valve (3).





---

**4-64. FRONT DOLLY PRESSURE PROTECTION VALVE REPLACEMENT (Con't).**

---

**b. INSTALLATION**

## NOTE

Male threads of fittings should be coated with antiseize tape if not already factory-coated with an antiseize compound.

1. Install elbow (2) on pressure protection valve (3).
2. Install pressure protection valve (3) on tee (4).
3. Connect tube assembly (1) to elbow (2).

Follow-on Tasks:

- Close air reservoir draincock (see paragraph 3-6).
- Connect intervehicular air hoses (see paragraph 2-11).
- Check for leaks (see paragraph 4-23).

---

## 4-65. AIRBRAKE VALVE REPLACEMENT.

---

This Task Covers:

- a. Removal
  - b. Cleaning
  - c. Installation
- 

Initial Setup:

Equipment Conditions:

- Wheels chocked.
- Air reservoir drained (see paragraph 3-6).

Tools/Test Equipment:

- General mechanic's tool kit (Item 30, Appendix G)

Materials/Parts:

- Sealing compound (Item 10, Appendix F)
- Rags (Item 25, Appendix F)
- Dry cleaning solvent (Item 27, Appendix F)
- Marker tags (Item 28, Appendix F)
- Antiseize tape (Item 29, Appendix F)

General Safety Instructions:

- Dry cleaning solvent is flammable and must not be used near an open flame. Use only in a well-ventilated area.
- 

### NOTE

- Front and rear dolly airbrake valves are replaced the same way except as noted.
- All air lines should be tagged before removal. Refer to paragraph 4-18 for tagging instructions.

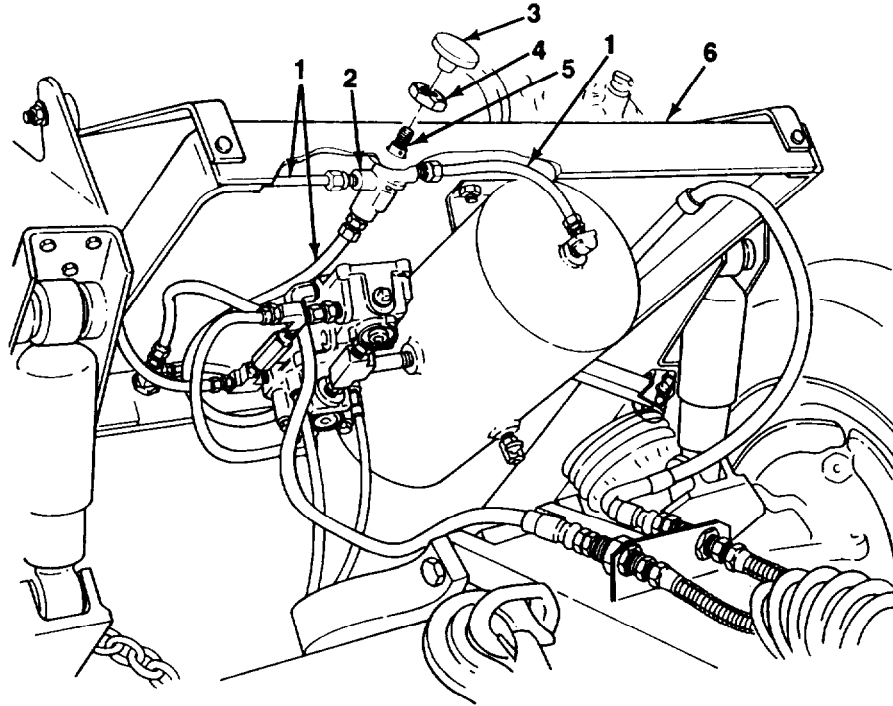
### **a. REMOVAL**

1. If working on front dolly, disconnect three tube assemblies (1) from airbrake valve (2).
2. If working on rear dolly, disconnect three tube assemblies (1) from elbows (7) at airbrake valve (2).
3. Hold stem (5) and remove control knob (3).
4. Remove nut (4) and airbrake valve (2) from pivoting tray (6).
5. If working on rear dolly, remove three elbows (7) from airbrake valve (2).

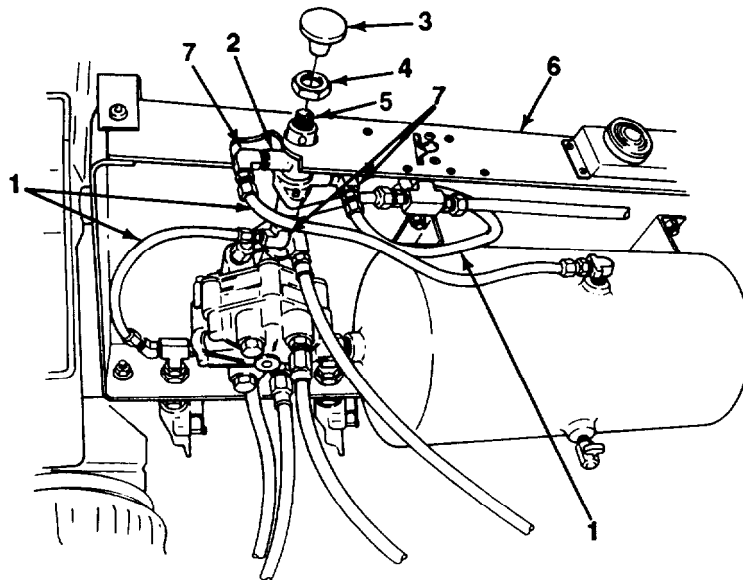
---

4-65. AIRBRAKE VALVE REPLACEMENT (Con't).

---



FRONT DOLLY



REAR DOLLY

4-65. AIRBRAKE VALVE REPLACEMENT (Con't).

**b. CLEANING**



Dry cleaning solvent, P-D-680, is toxic and flammable. Always wear protective goggles and gloves, and use only in a well-ventilated area. Avoid contact with skin, eyes, and clothes, and DO NOT breathe vapors. DO NOT use near open flame or excessive heat. The solvent's flash point is 100°F-138°F (38°C-59°C). If you become dizzy while using cleaning solvent, immediately get fresh air and medical help. If solvent contacts eyes, immediately wash your eyes and seek medical attention.

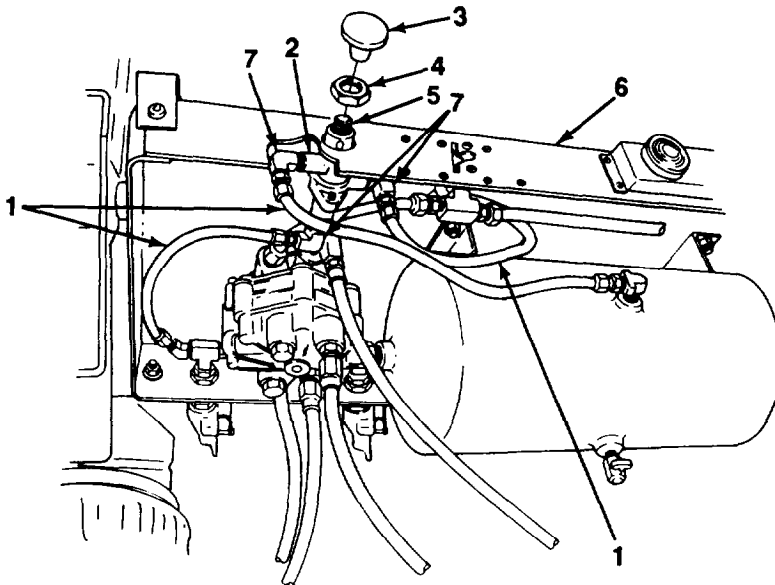
Clean sealing compound from threads of control knob and stem with dry cleaning solvent and dry with a clean rag.

**c. INSTALLATION**

NOTE

Male threads of fittings should be coated with antiseize tape if not already factory-coated with an antiseize compound.

1. If working on rear doily, install three elbows (7) on airbrake valve (2).



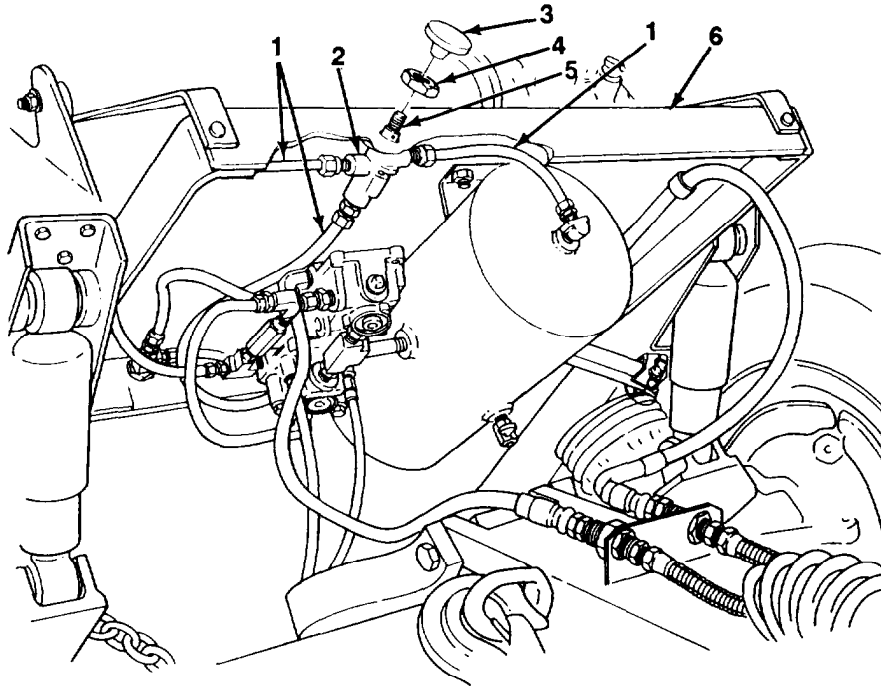
REAR DOLLY

---

**4-65. AIRBRAKE VALVE REPLACEMENT (Con't).**

---

2. Install airbrake valve (2) on pivoting tray (6) with nut (4).
3. Apply sealing compound to control knob (3). Hold stem (5) and install control knob.
4. If working on rear dolly, connect three tube assemblies (1) to elbows (7).
5. If working on front dolly, connect three tube assemblies (1) to airbrake valve (2).



FRONT DOLLY

**Follow-on Tasks:**

- Close air reservoir draincock (see paragraph 3-6).
- Connect intervehicular air hoses (see paragraph 2-11).
- Check for leaks (see paragraph 4-23).

---

## 4-66. REAR DOLLY FULL FUNCTION VALVE AND AIR RESERVOIR REPLACEMENT.

---

This Task Covers:

- a. Removal b. Installation
- 

Initial Setup:

Equipment Conditions:

- Wheels chocked.
- Air reservoir drained (see paragraph 3-6).
- Rear doily booster relay valve removed (see paragraph 4-67).

Materials/Parts:

- Marker tags (Item 28, Appendix F)
- Antiseize tape (Item 29, Appendix F)
- Four locknuts

Tools/Test Equipment:

- General mechanic's tool kit (Item 30, Appendix G)

Personnel Required: Two

---

### **a. REMOVAL**

#### NOTE

All air lines should be tagged before removal. Refer to paragraph 4-18 for tagging instructions.

1. Disconnect two hose assemblies (8) from underside of full function valve (1).

#### NOTE

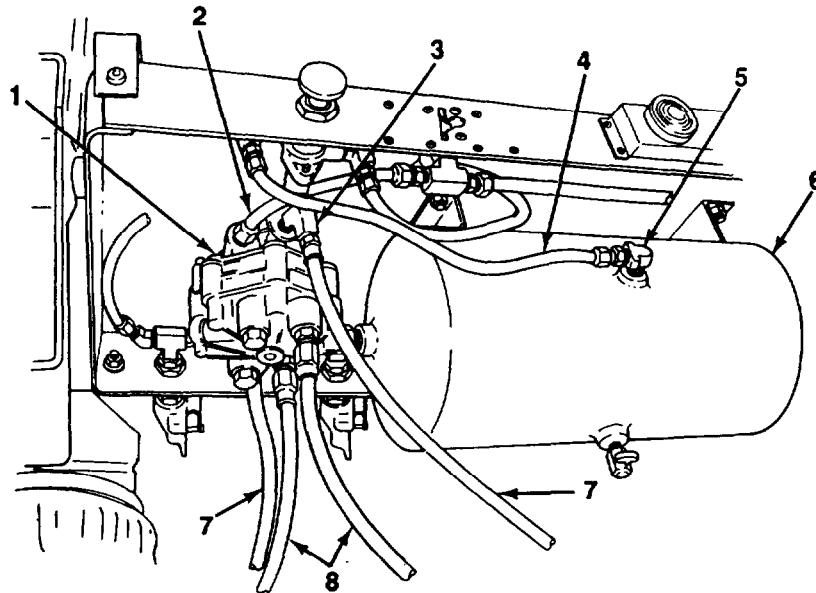
Disconnection of tube assemblies (2 and 7) is the same at front and rear of full function valve. Rear of full function valve is shown.

2. Disconnect two tube assemblies (2) from top of full function valve (1).
3. Disconnect two hose assemblies (7) from elbows (3).
4. Disconnect tube assembly (4) from elbow (5).

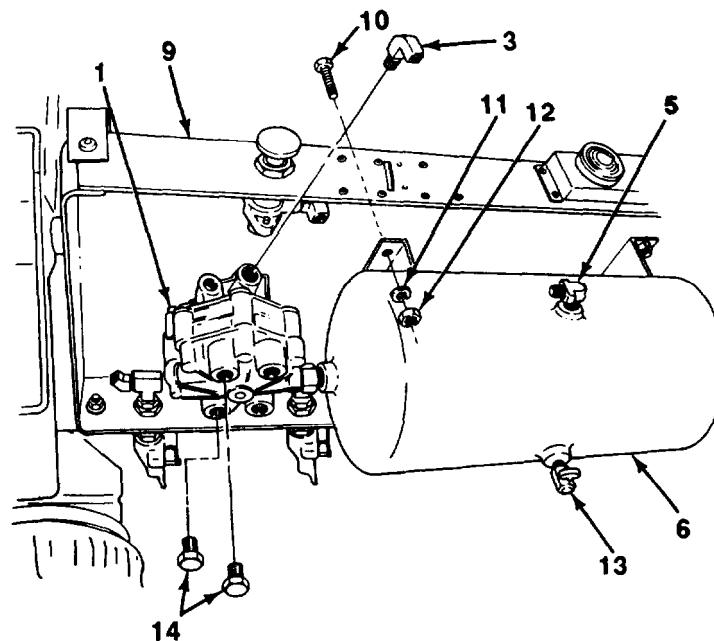
---

**4-66. REAR DOLLY FULL FUNCTION VALVE AND AIR RESERVOIR REPLACEMENT  
(Con't).**

---



5. Remove four locknuts (12), flatwashers (11), bolts (10), and air reservoir (6) with full function valve (1) from pivoting tray (9). Discard locknuts.
6. Remove full function valve (1) from air reservoir (6).
7. Remove elbow (5) and draincock (13) from air reservoir (6).
8. Remove two plugs (14) and elbows (3) from full function valve (1).



---

**4-66. REAR DOLLY FULL FUNCTION VALVE AND AIR RESERVOIR REPLACEMENT  
(Con't).**

---

**b. INSTALLATION**

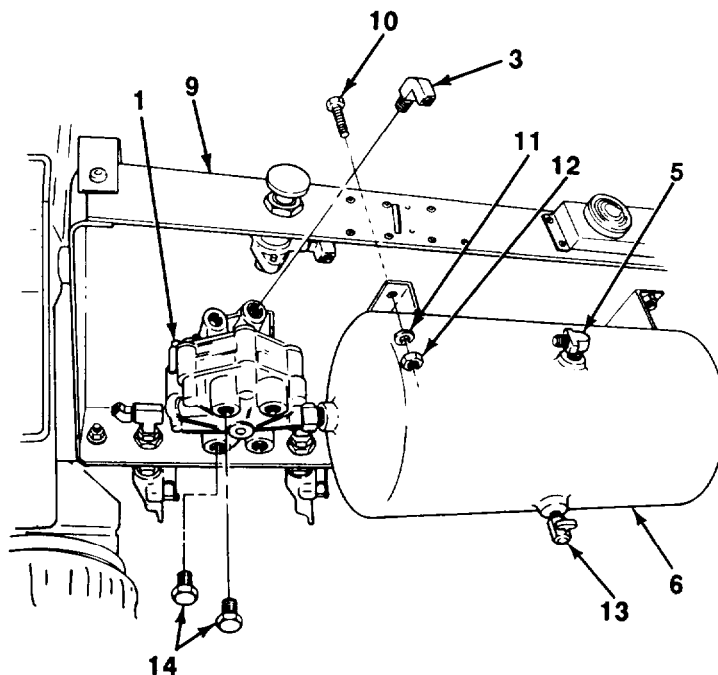
**CAUTION**

DO NOT overtighten fittings at full function valve or damage to full function valve will occur.

NOTE

Male threads of fittings should be coated with antiseize tape if not already factory-coated with an antiseize compound.

1. Install two plugs (14) and elbows (3) on full function valve (1).
2. Install draincock (13) and elbow (5) on air reservoir (6).
3. Install full function valve (1) on air reservoir (6).
4. Install air reservoir (6) with full function valve (1) on pivoting tray (9) with four bolts (10), flatwashers (11), and new locknuts (12).





---

**4-66. REAR DOLLY FULL FUNCTION VALVE AND AIR RESERVOIR REPLACEMENT (Con't).**

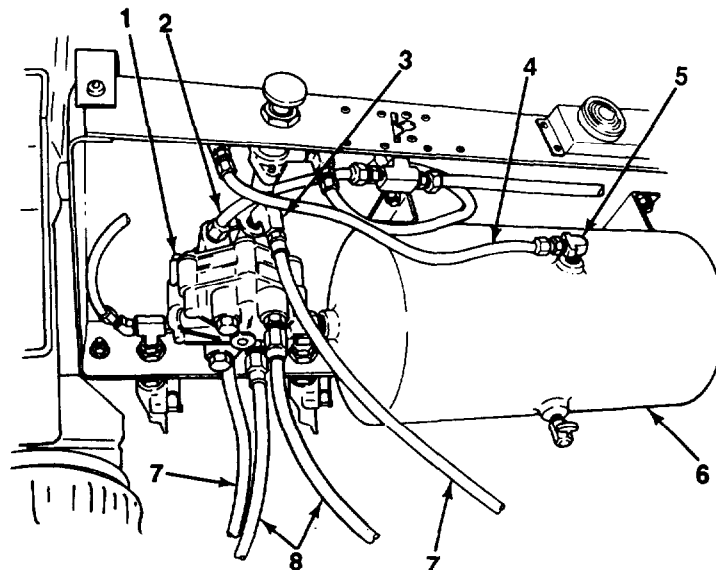
---

5. Connect tube assembly (4) to elbow (5).

## NOTE

Connection of tube assemblies (2 and 7) is the same at front and rear of full function valve. Rear of full function valve is shown.

6. Connect two hose assemblies (7) to elbows (3).
7. Connect two tube assemblies (2) to top of full function valve (1).
8. Connect two hose assemblies (8) to underside of full function valve (1).

Follow-on Tasks:

- Install rear dolly booster relay valve (see paragraph 4-67).
- Close air reservoir draincock (see paragraph 3-6).
- Connect intervehicular air hoses (see paragraph 2-11).
- Check for leaks (see paragraph 4-23).

---

## 4-67. REAR DOLLY BOOSTER RELAY VALVE REPLACEMENT.

---

This Task Covers:

- a. Removal b. Installation
- 

Initial Setup:

Equipment Conditions:

- Wheels chocked.
- Air reservoir drained (see paragraph 3-6).

Materials/Parts:

- Marker tags (Item 28, Appendix F)
- Antiseize tape (Item 29, Appendix F)

Tools/Test Equipment:

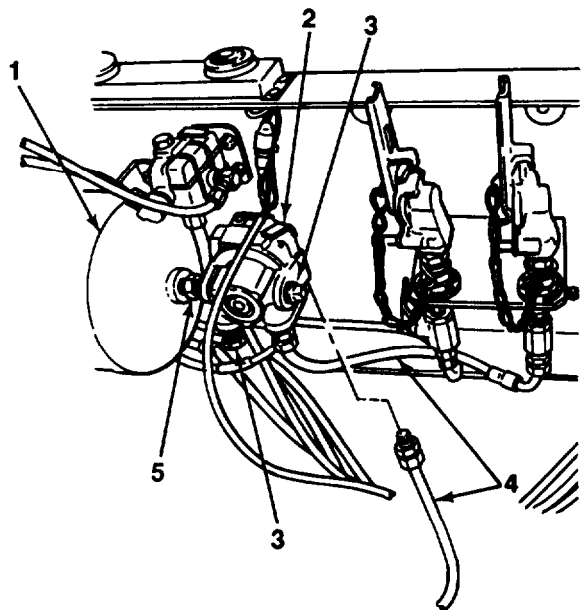
- General mechanic's tool kit (Item 30, Appendix G)
- 

### **a. REMOVAL**

#### NOTE

All air lines should be tagged before removal. Refer to paragraph 4-18 for tagging instructions.

1. Disconnect two tube assemblies (4) from booster relay valve (2).
2. Remove booster relay valve (2) from nipple (5).
3. Remove two plugs (3) from booster relay valve (2)
4. If damaged, remove nipple (5) from air reservoir (1).



---

**4-67. REAR DOLLY BOOSTER RELAY VALVE REPLACEMENT (Con't).**

---

**b. INSTALLATION**

## NOTE

Male threads of fittings should be coated with antiseize tape if not already factory-coated with an antiseize compound.

1. If removed, install nipple (5) on air reservoir (1).
2. Install two plugs (3) on booster relay valve (2).
3. Install booster relay valve (2) on nipple (5).
4. Connect two tube assemblies (4) to booster relay valve (2).

Follow-on Tasks:

- Close air reservoir draincock (see paragraph 3-6).
- Connect intervehicular air hoses (see paragraph 2-11).
- Check for leaks (see paragraph 423).

## 4-68. REAR DOLLY SHUTOFF VALVE AND MOUNTING BRACKET REPLACEMENT.

This Task Covers:

- |            |                 |
|------------|-----------------|
| a. Removal | b. Installation |
|------------|-----------------|

initial Setup:

Equipment Conditions:

- Wheels chocked.
- Air reservoir drained (see paragraph 3-6).

Materials/Parts:

- Antiseize tape (Item 29, Appendix F)

Tools/Test Equipment:

- General mechanic's tool kit (Item 30, Appendix G)
- Adjustable wrench (Item 37, Appendix G)

### NOTE

Both rear dolly shutoff valves are replaced the same way. Right side (service) shutoff valve is illustrated.

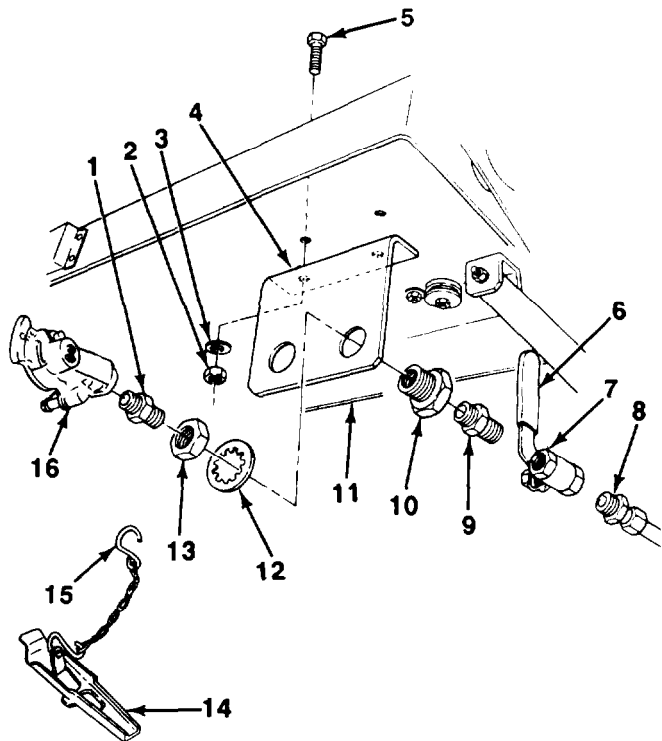
### a. REMOVAL

1. Disconnect tube assembly (8) from shutoff valve (7)
2. Remove shutoff valve (7) from reducer (9).

### NOTE

Perform steps 3 through 8 only if reducer, anchor coupling, or mounting bracket are damaged.

3. Remove reducer (9) from anchor coupling (10).
4. Remove dummy coupling (14) from gladhand (16).
5. Unbend S-hook (15) and remove dummy coupling (14) from nipple (1).
6. Remove gladhand (16) and nipple (1) from anchor coupling (10).
7. Remove nut (13), star-washer (12), and anchor coupling (10) from mounting bracket (4).
8. Remove two locknuts (2) flatwashers (3), bolts (5), and mounting bracket (4) from pivoting tray (11). Discard locknuts.



---

## 4-68. REAR DOLLY SHUTOFF VALVE AND MOUNTING BRACKET REPLACEMENT (Con't).

---

**b. INSTALLATION**

## NOTE

- Male threads of fittings should be coated with antiseize tape if not already factory-coated with an antiseize compound.
  - Perform steps 1 through 5 only if reducer, anchor coupling, or mounting bracket were removed.
1. Install mounting bracket (4) on pivoting tray (11) with two bolts (5) flatwashers (3), and new locknuts (2).
  2. Install anchor coupling (10) on mounting bracket (4) with starwasher (12) and nut (13).
  3. Install nipple (1) and gladhand (16) on anchor coupling (10). Ensure that gladhand is properly positioned when tight.
  4. Install dummy coupling (14) by hooking S-hook (15) around nipple (1) and bending S-hook to tighten. Install dummy coupling on gladhand (16).
  5. Install reducer (9) on anchor coupling (10).

## NOTE

When valve is in closed position, handle (6) should be facing up.

6. Install shutoff valve (7) on reducer (9).
7. Connect tube assembly (8) to shutoff valve (7).

Follow-on Tasks:

- Close air reservoir draincock (see paragraph 3-6).
- Connect intervehicular air hoses (see paragraph 2-11).
- Check for leaks (see paragraph 4-23).

---

## 4-69. REAR DOLLY PARKING BRAKE VALVE REPLACEMENT.

---

This Task Covers:

- |            |                 |
|------------|-----------------|
| a. Removal | b. Installation |
|------------|-----------------|
- 

Initial Setup:

Equipment Conditions:

- Wheels chocked.
- Air reservoir drained (see paragraph 3-8).

Materials/Parts:

- Marker tags (Item 28, Appendix F)
- Antiseize tape (Item 29, Appendix F)
- Two lockwashers

Tools/Test Equipment:

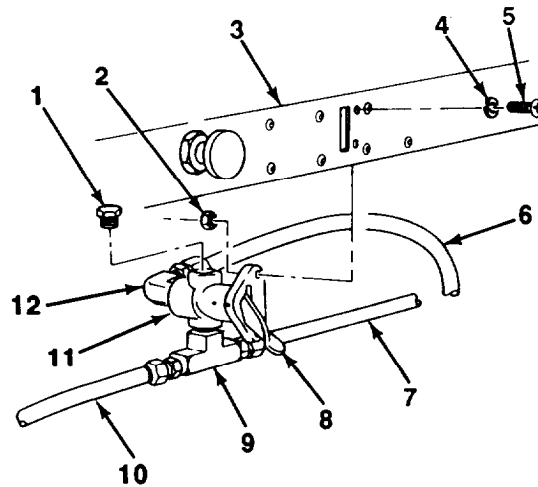
- General mechanic's tool kit (Item 30, Appendix G)
- 

### **a. REMOVAL**

#### NOTE

All air lines should be tagged before removal. Refer to paragraph 4-18 for tagging instructions.

1. Place parking brake lever (8) in OFF position.
2. Disconnect tube assemblies (7 and 10) from tee (9).
3. Disconnect tube assembly (6) from elbow (12).
4. Remove two nuts (2), screws (5), lockwashers (4), and parking brake valve (11) from pivoting tray (3). Discard lockwashers.
5. Remove elbow (12) tee (9) and plug (1) from parking brake valve (11).



---

**4-69. REAR DOLLY PARKING BRAKE VALVE REPLACEMENT (Con't).**

---

**b. INSTALLATION****CAUTION**

**DO NOT overtighten fittings at parking brake valve or damage to parking brake valve will occur.**

**NOTE**

**Male threads of fittings should be coated with antiseize tape if not already factory-coated with an antiseize compound.**

1. Install plug (1), tee (9), and elbow (12) on parking brake valve (11).
2. Install parking brake valve (11) on pivoting tray (3) with two new lockwashers (4), screws (5), and nuts (2).
3. Connect tube assembly (6) to elbow (12).
4. Connect tube assemblies (7 and 10) to tee (9).
5. Place parking brake lever (8) in ON position.

**Follow-on Tasks:**

- Close air reservoir draincock (see paragraph 3-6).
- Connect intervehicular air hoses (see paragraph 2-11).
- Check for leaks (see paragraph 4-23).

---

## 4-70. REAR DOLLY RELAY VALVE REPLACEMENT.

---

*This Task Covers:*

- a. Removal
- b. Installation

---

*Initial Setup:*

**Equipment Conditions:**

- Wheels chocked.
- Air reservoir drained (see paragraph 3-6).

**Materials/Parts:**

- Marker tags (Item 28, Appendix F)
- Antiseize tape (Item 29, Appendix F)
- Two locknuts

**Tools/Test Equipment:**

- General mechanic's tool kit (item 30, Appendix G)

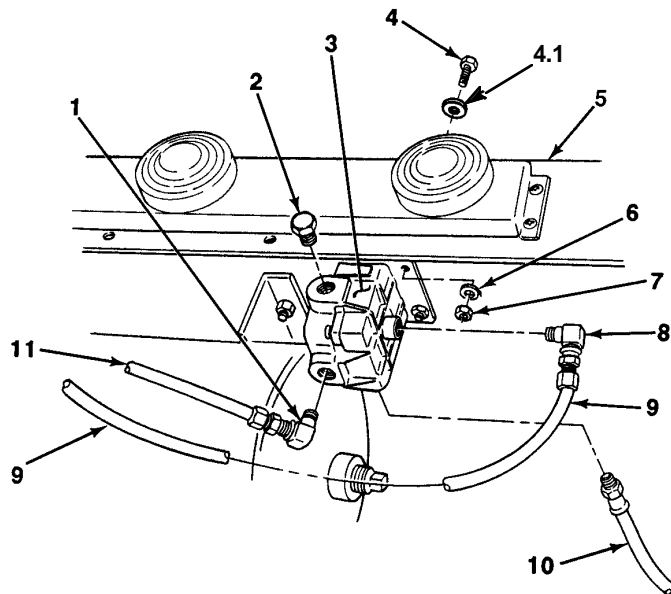
---

a. <b>REMOVAL</b>
-------------------

**NOTE**

**All air lines should be tagged before removal. Refer to paragraph 4-18 for tagging instructions.**

1. Disconnect tube assembly (10) from relay valve (3).
2. Disconnect tube assembly (9) from elbow (8).





---

**4-70. REAR DOLLY RELAY VALVE REPLACEMENT (Con't).**

---

3. Disconnect tube assembly (11) from elbow (1).
4. Remove two locknuts (7), flatwashers (6), bolts (4), flatwashers (4.1), and relay valve (3) from pivoting tray (5). Discard locknuts.
5. Remove plug (2) and two elbows (1 and 8) from relay valve (3).

<b>b. INSTALLATION</b>
------------------------

<b>CAUTION</b>
----------------

**DO NOT overtighten fittings at relay valve or damage to relay valve will occur.**

**NOTE**

**Male threads of fittings should be coated with antiseize tape if not already factory-coated with an antiseize compound.**

1. Install plug (2) and two elbows (1 and 8) on relay valve (3).
2. Install relay valve (3) on pivoting tray (5) with two bolts (4), flatwashers (4.1 and 6), and new locknuts (7).
3. Connect tube assembly (11) to elbow (1).
4. Connect tube assembly (9) to elbow (8).
5. Connect tube assembly (10) to relay valve (3).

**Follow-on Tasks:**

- Close air reservoir draincock (see paragraph 3-6).
- Connect Intervehicular air hoses (see paragraph 2-11).
- Check for leaks (see paragraph 4-23).

---

## 4-71. PIVOTING TRAY GLADHAND REPLACEMENT.

---

*This Task Covers:*

- a. Preformed Packing Replacement
- b. Removal
- c. Installation

---

*Initial Setup:*

**Equipment Conditions:**

- Wheels chocked.
- Air reservoir drained (see paragraph 3-6).

**Materials/Parts:**

- Rags (Item 25, Appendix F)

- Antiseize tape (Item 29, Appendix F)
- One preformed packing

**Tools/Test Equipment:**

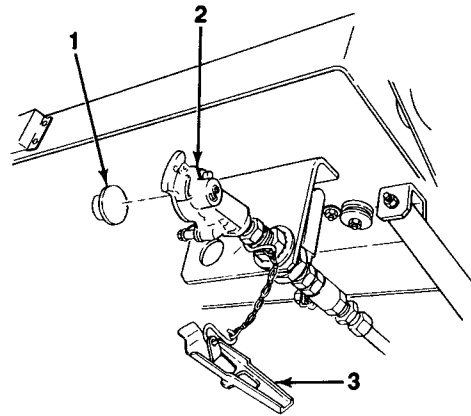
- General mechanic's tool kit (Item 30, Appendix G)
  - Adjustable wrench (Item 37, Appendix G)
- 

**NOTE**

- Front and rear dolly pivoting tray gladhands are maintained the same way except that rearmost gladhands on rear dolly pivoting tray have dummy couplings and are mounted to a mounting bracket instead of to the pivoting tray.
- Intervehicular air hose gladhands replacement is described in paragraph 4-72.

<b>a. PREFORMED PACKING REPLACEMENT</b>
---

1. Remove dummy coupling (3) from gladhand (2).
2. Remove preformed packing (1) from groove in face of gladhand (2). Discard preformed packing.
3. Clean groove in face of gladhand (2) with a clean rag.
4. Install new preformed packing (1) in groove on face of gladhand (2). Push into place so that preformed packing lies flat.
5. Install dummy coupling (3) on gladhand (2).



---

**4-71. PIVOTING TRAY GLADHAND REPLACEMENT (Con't).**

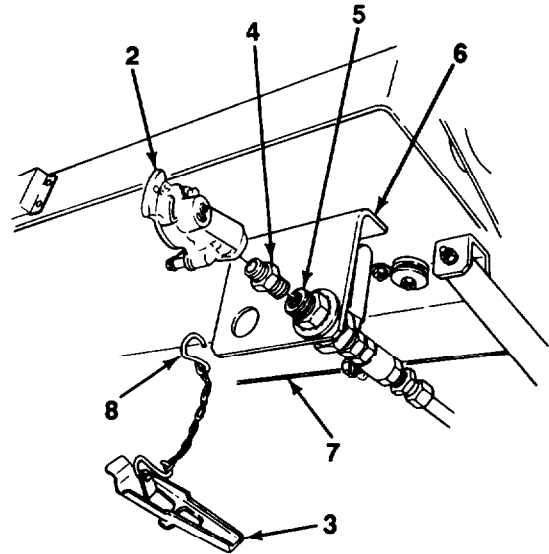

---

**b. REMOVAL**

## NOTE

Perform steps 1 and 2 only if removing rearmost gladhand on rear dolly pivoting tray.

1. Remove dummy coupling (3) from gladhand (2).
2. Unbend S-hook (8) and remove dummy coupling (3) from nipple (4).
3. Remove gladhand (2) from nipple (4).
4. If nipple (4) is damaged, remove nipple from anchor coupling (5) at pivoting tray (7) or mounting bracket (6).

**c. INSTALLATION**

## NOTE

Male threads of fittings should be coated with antiseize tape if not already factory-coated with an antiseize compound.

1. If removed, install nipple (4) on anchor coupling (5) at pivoting tray (7) or mounting bracket (6).
2. Install gladhand (2) on nipple (4). Ensure that gladhand is properly positioned when tight.

## NOTE

Perform step 3 only if installing rearmost gladhand on rear dolly pivoting tray.

3. Install dummy coupling (3) by hooking S-hook (8) around nipple (4) and bending S-hook to tighten. Install dummy coupling on gladhand (2).

Follow-on Tasks:

- Close air reservoir draincock (see paragraph 3-6).
- Connect intervehicular air hoses (see paragraph 2-11).
- Check for leaks (see paragraph 4-23).

---

## 4-72. FRONT DOLLY AIR LINES REPLACEMENT.

---

This Task Covers:

- |   |  |
|---|--|
| a. Intervehicular Air Hose Replacement  | f. Airbrake Valve-to-Air Reservoir Tube Assembly Replacement         |
| b. Relay Emergency Valve-to-Airbrake Chamber Hose Assembly Replacement          | g. Relay Emergency Valve-to-Right Side Tee Tube Assembly Replacement |
| c. Pressure Protection Valve-to-Relay Emergency Valve Tube Assembly Replacement | h. Booster Relay Valve-to-Right Side Tee Tube Assembly Replacement   |
| d. Airbrake Valve-to-Relay Emergency Valve Tube Assembly Replacement            |  |
| e. Airbrake Valve-to-Left Side Tee Tube Assembly Replacement                    |  |
- 

Initial Setup:

Equipment Conditions:

- Wheels chocked.
- Air reservoir drained (see paragraph 3-6).

Materials/Parts:

- Marker tags (Item 28, Appendix F)
- Antiseize tape (Item 29, Appendix F)
- One locknut

Tools/Test Equipment:

- General mechanic's tool kit (Item 30, Appendix G)
  - Adjustable wrench (Item 37, Appendix G)
- 

### NOTE

- All air lines should be tagged before removal. Refer to paragraph 4-16 for tagging instructions.
- Before connection, male threads of fittings should be coated with antiseize tape if not already factory-coated with an antiseize compound.

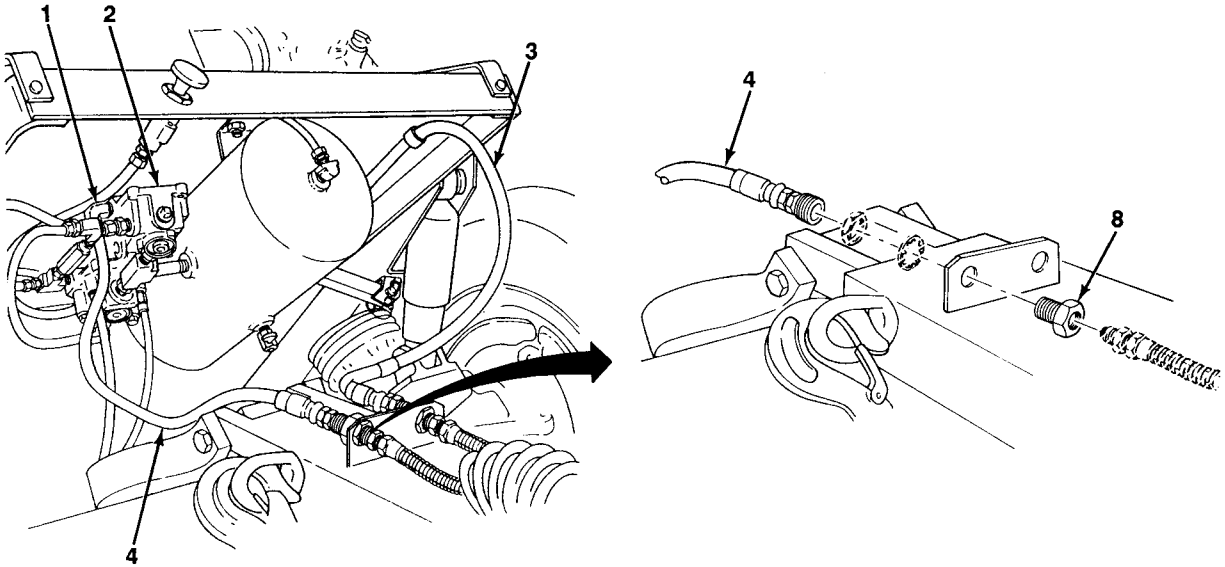
### a. INTERVEHICULAR AIR HOSE REPLACEMENT

### NOTE

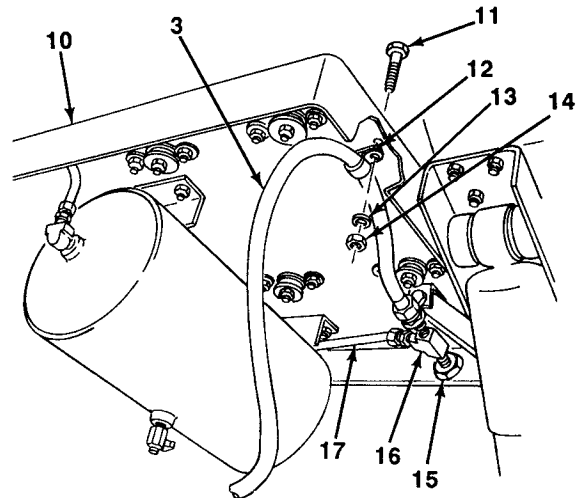
Left side (emergency) and right side (service) intervehicular air hoses are replaced the same way except as noted.

1. Disconnect hose assembly (3 or 4) from anchor coupling (8).
2. Disconnect hose assembly (4) from elbow (1) at booster relay valve (2). Remove hose assembly.

**4-72. FRONT DOLLY AIR LINES REPLACEMENT (Con't).**



3. Remove locknut (14), flatwasher (13), cap-screw (11), and clamp (12) from hose assembly (3) and pivoting tray (10). Discard locknut.
4. Disconnect hose assembly (3) from tee (16). Remove hose assembly.
5. If tee (16) is damaged, disconnect tube assembly (17) from tee and remove tee from anchor coupling (15).

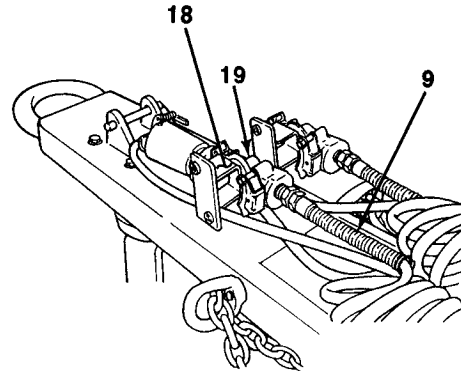


---

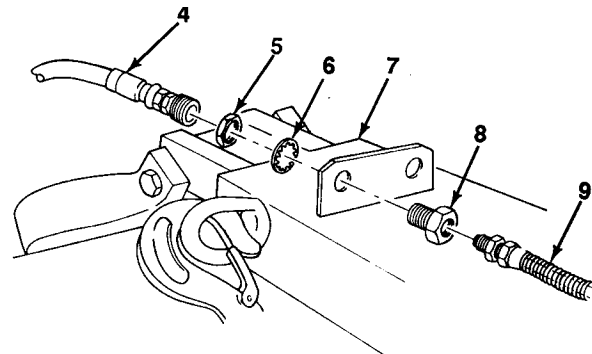
## 4-72. FRONT DOLLY AIR LINES REPLACEMENT (Con't).

---

6. Remove gladhand (19) from dummy coupling (18).
7. Disconnect coil tubing (9) from anchor coupling (8).
8. Separate gladhand (19), identification plate, and coil tubing (9).



9. If anchor coupling (8) is damaged, remove nut (5), starwasher (6), and anchor coupling from front drawbar (7).
10. If removed, install anchor coupling (8) on front drawbar (7) with starwasher (6) and nut (5).



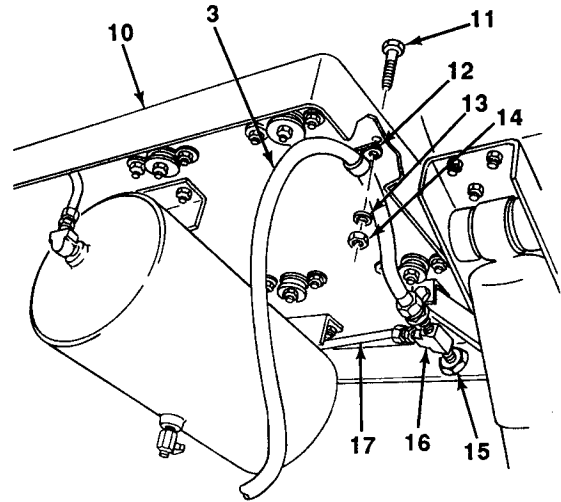
### NOTE

**Red coil tubing is installed on left side; blue coil tubing is installed on right side.**

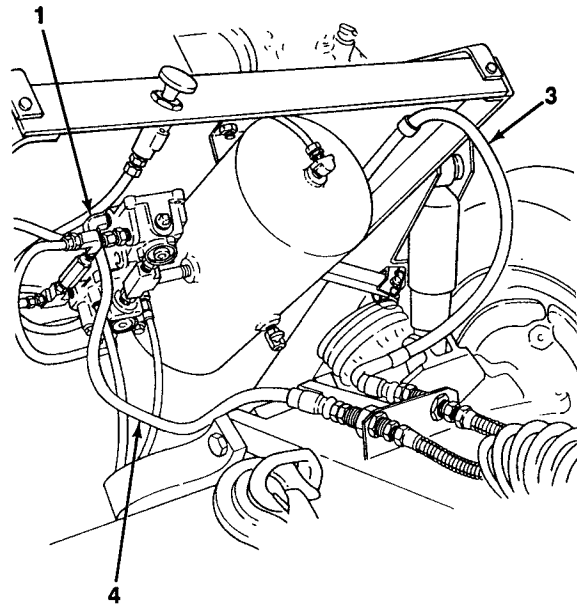
11. Assemble coil tubing (9), identification plate, and gladhand (19).
12. Connect coil tubing (9) to anchor coupling (8).
13. Install gladhand (19) on dummy coupling (18).

## 4-72. FRONT DOLLY AIR LINES REPLACEMENT (Con't).

14. If removed, install tee (16) on anchor coupling (15). Connect tube assembly (17) to tee.
15. Connect hose assembly (3) to tee (16).
16. Install hose assembly (3) on pivoting tray (10) with clamp (12), capscrew (11), flatwasher (13), and new locknut (14).



17. Connect hose assembly (4) to elbow (1).
18. Connect hose assembly (3 or 4) to anchor coupling (8).



---

## 4-72. FRONT DOLLY AIRLINES REPLACEMENT (Con't).

---

<b>b. RELAY EMERGENCY VALVE-TO-AIRBRAKE CHAMBER HOSE ASSEMBLY REPLACEMENT</b>
---

**NOTE**

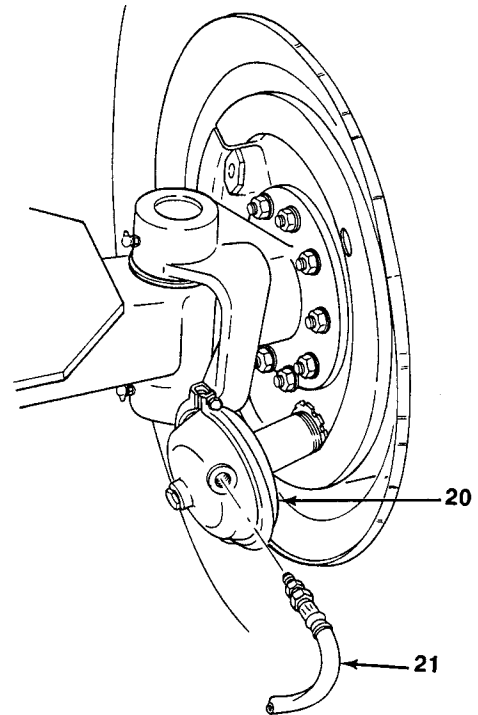
Left side and right side hose assemblies are replaced the same way. Right side hose assembly is illustrated.

1. Disconnect hose assembly (21) from airbrake chamber (20).
2. Remove spring (23) from eyebolt (24).

**NOTE**

Hose assembly to other airbrake chamber is removed at same time.

3. Remove nut (25) from eyebolt (24) and separate hose clamp (26). Release hose assembly (21).
4. Disconnect hose assembly (21) from relay emergency valve (22). Remove hose assembly.
5. Connect hose assembly (21) to relay emergency valve (22).
6. Connect hose assembly (21) to airbrake chamber (20).



**NOTE**

Hose assembly to other airbrake chamber is installed at same time.

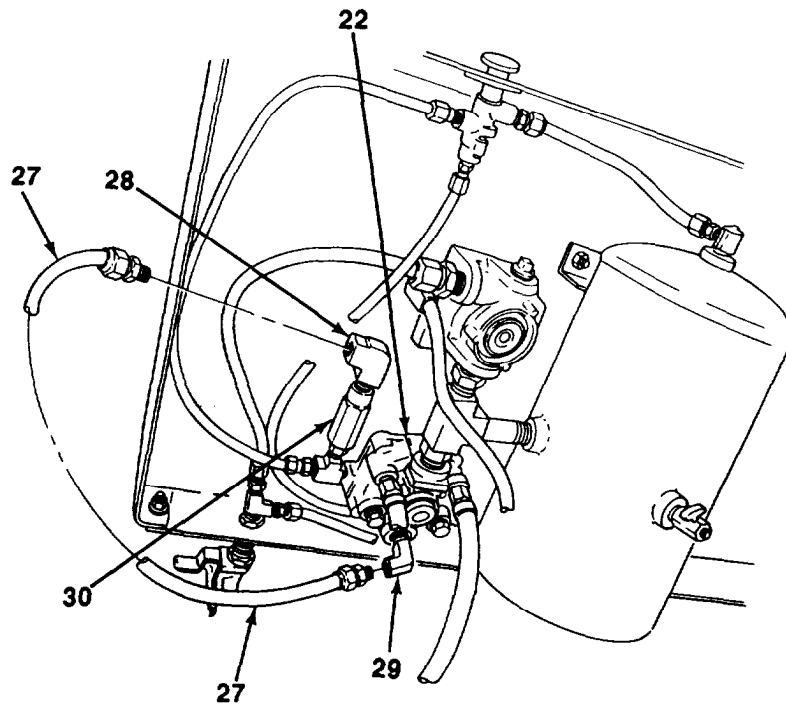
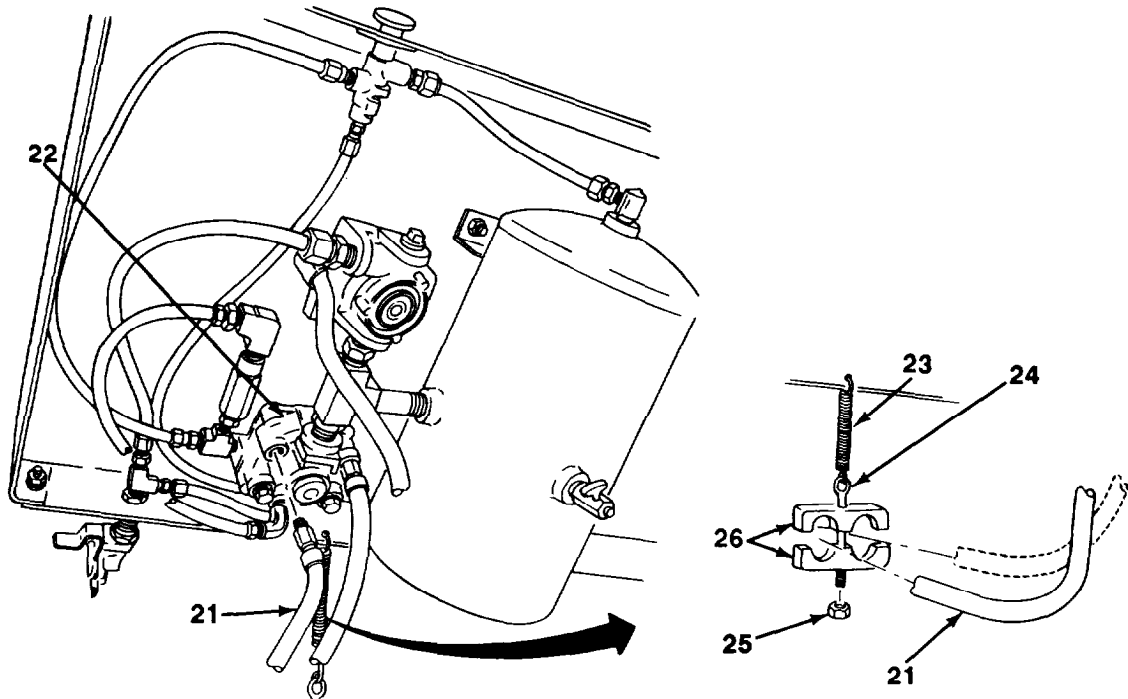
7. Install hose assembly (21) in hose clamp (26) and secure with eyebolt (24) and nut (25).
8. Install spring (23) on eyebolt (24).

<b>c. PRESSURE PROTECTION VALVE-TO-RELAY EMERGENCY VALVE TUBE ASSEMBLY REPLACEMENT</b>
--

1. Disconnect tube assembly (27) from elbow (29) at relay emergency valve (22).
2. Disconnect tube assembly (27) from elbow (28) at pressure protection valve (30). Remove tube assembly.
3. Connect tube assembly (27) to elbow (28).
4. Connect tube assembly (27) to elbow (29).



4-72. FRONT DOLLY AIR LINES REPLACEMENT (Con't).



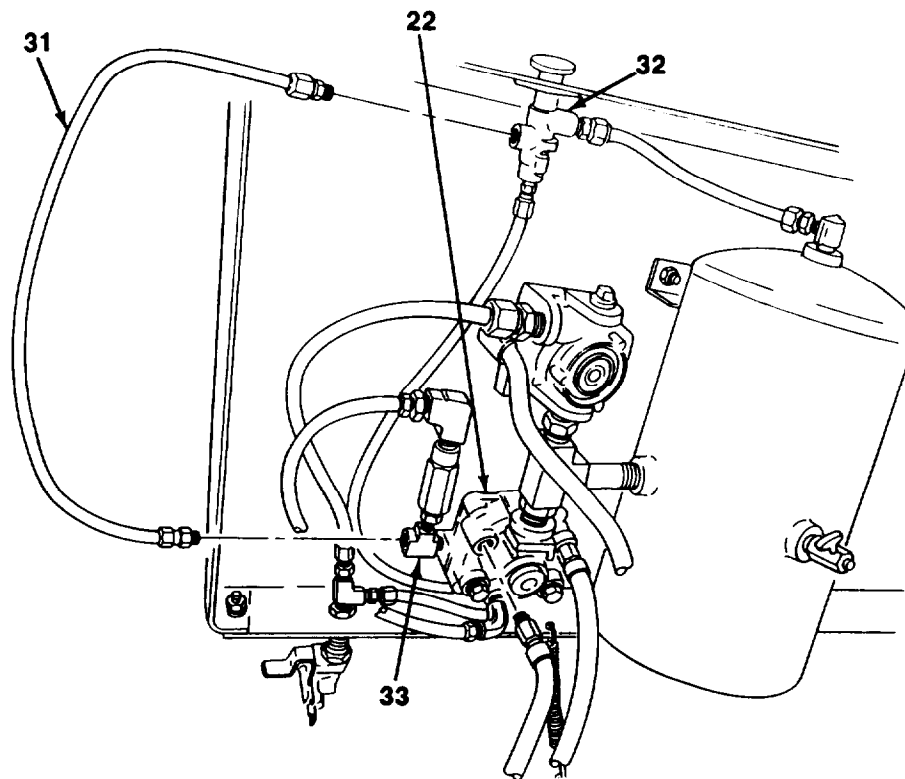
---

**4-72. FRONT DOLLY AIR LINES REPLACEMENT (Con't).**

---

**d. AIRBRAKE VALVE-TO-RELAY EMERGENCY VALVE TUBE ASSEMBLY REPLACEMENT**

1. Disconnect tube assembly (31) from airbrake valve (32).
2. Disconnect tube assembly (31) from tee (33) at relay emergency valve (22). Remove tube assembly.
3. Connect tube assembly (31) to tee (33).
4. Connect tube assembly (31) to airbrake valve (32).



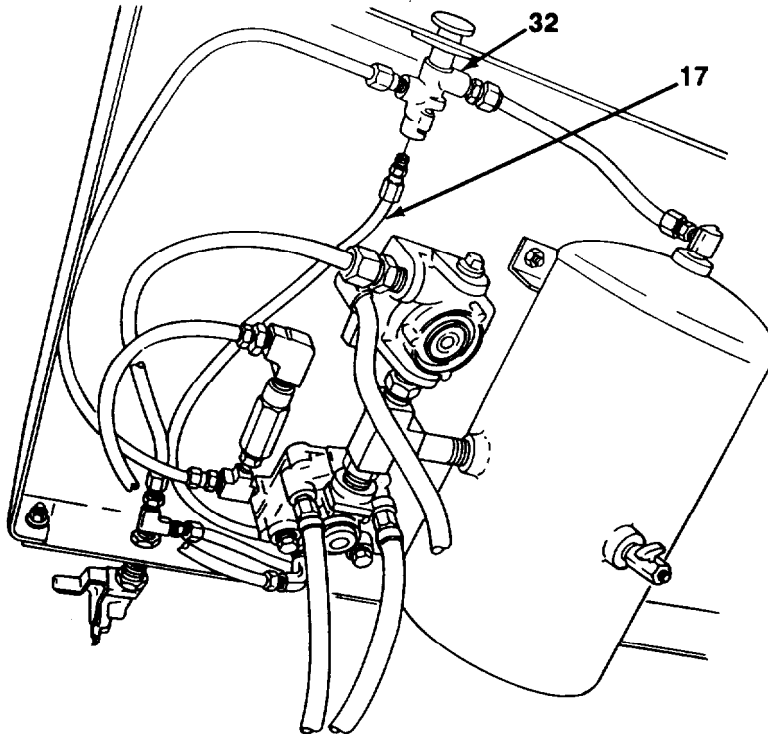
---

**4-72. FRONT DOLLY AIR LINES REPLACEMENT (Con't).**

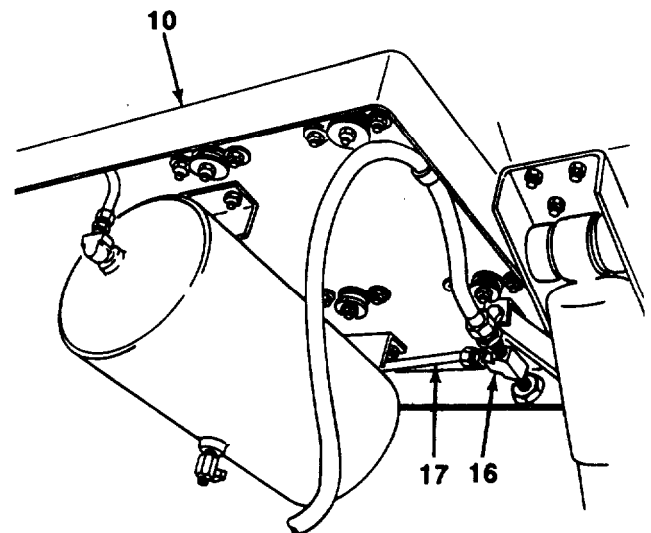
---

**e. AIRBRAKE VALVE-TO-LEFT SIDE TEE TUBE ASSEMBLY REPLACEMENT**

1. Disconnect tube assembly (17) from airbrake valve (32).
2. Disconnect tube assembly (17) from tee (16) on left side of pivoting tray (10). Remove tube assembly.



3. Connect tube assembly (17) to tee (16).
4. Connect tube assembly (17) to airbrake valve (32).



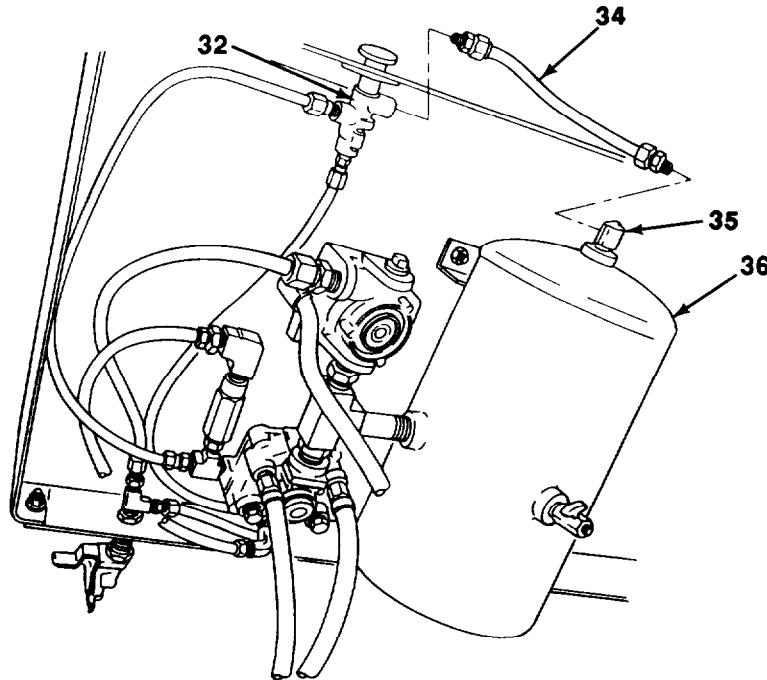
---

**4-72. FRONT DOLLY AIR LINES REPLACEMENT (Con't).**

---

**f. AIRBRAKE VALVE-TO-AIR RESERVOIR TUBE ASSEMBLY REPLACEMENT**

1. Disconnect tube assembly (34) from airbrake valve (32).
2. Disconnect tube assembly (34) from elbow (35) at air reservoir (36). Remove tube assembly.
3. If damaged, remove elbow (35) from air reservoir (36).



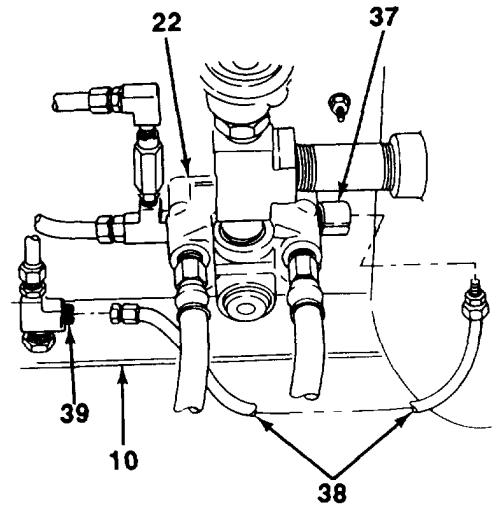
4. If removed, install elbow (35) on air reservoir (36).
5. Connect tube assembly (34) to elbow (35).
6. Connect tube assembly (34) to airbrake valve (32).

**g. RELAY EMERGENCY VALVE-TO-RIGHT SIDE TEE TUBE ASSEMBLY REPLACEMENT**

1. Disconnect tube assembly (38) from elbow (37) at top rear of relay emergency valve (22).
2. Disconnect tube assembly (38) from tee (39) on right side of pivoting tray (10). Remove tube assembly.

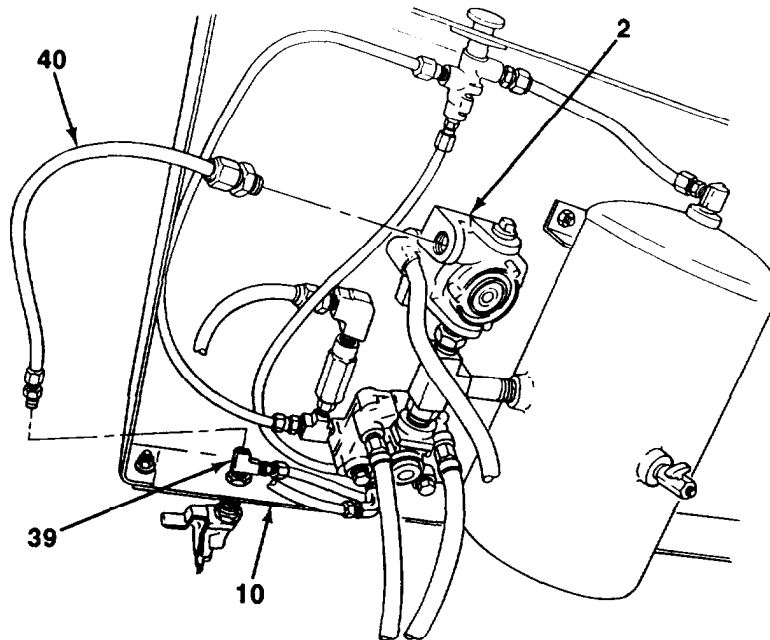
**4-72. FRONT DOLLY AIR LINES REPLACEMENT (Con't).**

3. Connect tube assembly (38) to tee (39).
4. Connect tube assembly (38) to elbow (37).



**h. BOOSTER RELAY VALVE-TO-RIGHT SIDE TEE TUBE ASSEMBLY REPLACEMENT**

1. Disconnect tube assembly (40) from booster relay valve (2).
2. Disconnect tube assembly (40) from tee (39) on right side of pivoting tray (10). Remove tube assembly.

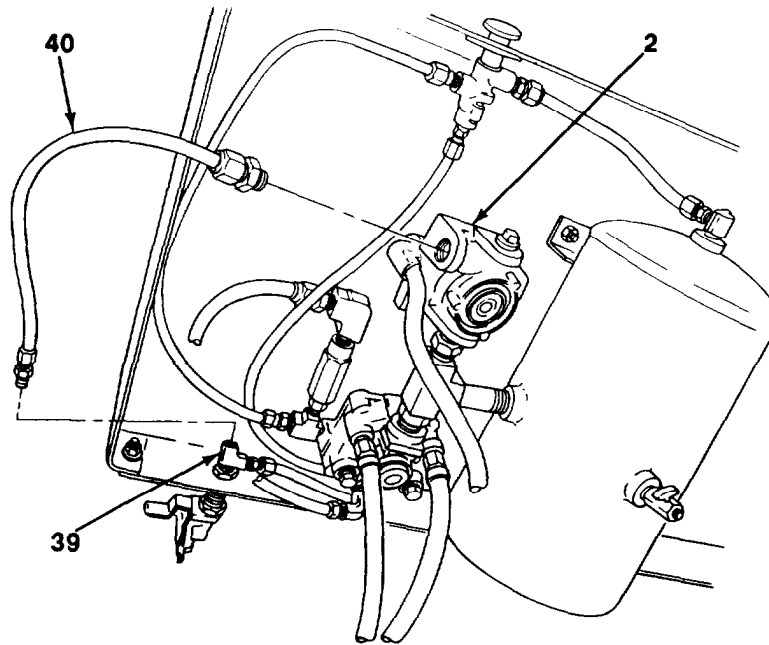


---

#### 4-72. FRONT DOLLY AIR LINES REPLACEMENT (Con't).

---

3. Connect tube assembly (40) to tee (39).
4. Connect tube assembly (40) to booster relay valve (2).



Follow-on Tasks:

- Close air reservoir draincock (see paragraph 3-6).
- Connect intervehicular air hoses (see paragraph 2-11).
- Check for leaks (see paragraph 4-23).

---

## 4-73. REAR DOLLY AIR LINES REPLACEMENT.

---

This Task Covers:

- |   |  |
|---|--|
| a. Full Function Valve-to-Airbrake Chamber Hose Assemblies Replacement  | g. Booster Relay Valve-to-Tee Tube Assembly Replacement                                |
| b. Full Function Valve-to-Relay Valve Tube Assembly Replacement         | h. Booster Relay Valve-to-Right Side (Service) Shutoff Valve Tube Assembly Replacement |
| c. Full Function Valve-to-Parking Brake Valve Tube Assembly Replacement | i. Left Side (Emergency) Shutoff Valve-to-Tee Tube Assembly Replacement                |
| d. Air-brake Valve-to-Air Reservoir Tube Assembly Replacement           | j. Relay Valve-to-Parking Brake Valve Tube Assembly Replacement                        |
| e. Air-brake Valve-to-Tee Tube Assembly Replacement                     | k. Relay Valve-to-Tee Tube Assembly Replacement  |
| f. Airbrake Valve-to-Parking Brake Valve Tube Assembly Replacement      |  |
- 

Initial Setup:

Equipment Conditions:

- Wheels chocked.
- Air reservoir drained (see paragraph 3-6).

Materials/Parts:

- Marker tags (Item 28, Appendix F)
- Antiseize tape (Item 29, Appendix F)

Tools/Test Equipment:

- General mechanic's tool kit (Item 30, Appendix G)
- 

### NOTE

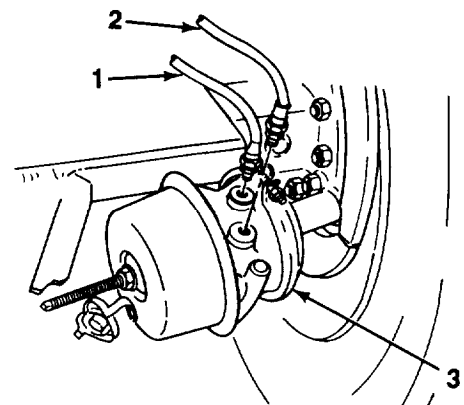
- All air lines should be tagged before removal. Refer to paragraph 4-18 for tagging instructions.
- Before connection, male threads of fittings should be coated with antiseize tape if not already factory-coated with an antiseize compound.

a. FULL FUNCTION VALVE-TO-AIRBRAKE CHAMBER HOSE ASSEMBLIES REPLACEMENT
--

### CAUTION

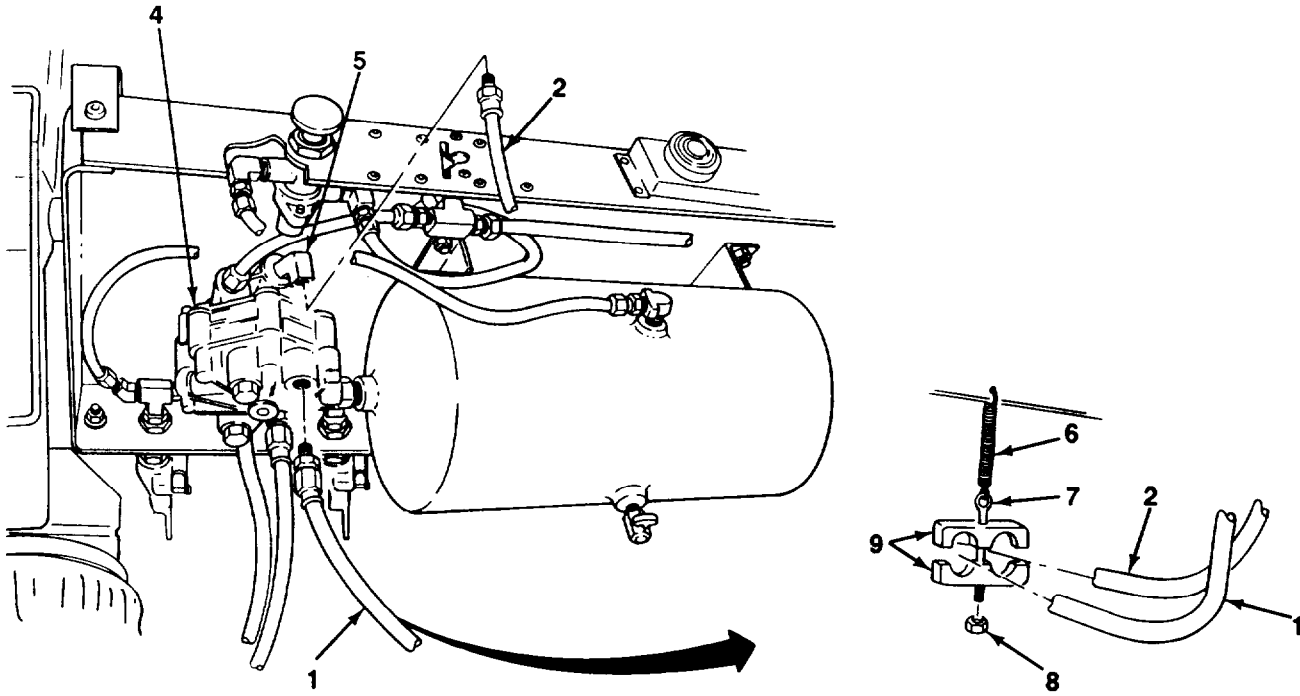
DO NOT overtighten fittings at full function valve or damage to full function valve will occur.

1. Disconnect hose assembly (1) from airbrake chamber (3).
2. Disconnect hose assembly (2) from airbrake chamber (3).

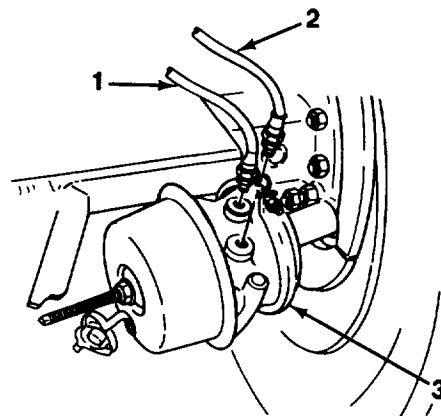


**4-73. REAR DOLLY AIR LINES REPLACEMENT (Con't).**

3. Remove spring (6) from eyebolt (7).
4. Remove nut (8) from eyebolt (7) and separate hose clamp (9). Release hose assemblies (1 and 2).
5. Disconnect hose assembly (1) from full function valve (4). Remove hose assembly.
6. Disconnect hose assembly (2) from elbow (5) at full function valve (4). Remove hose assembly.
7. Connect hose assembly (2) to elbow (5).



8. Connect hose assembly (2) to airbrake chamber (3).
9. Connect hose assembly (1) to full function valve (4).
10. Connect hose assembly (1) to airbrake chamber (3).
11. Install hose assemblies (1 and 2) in hose clamp (9) and secure with eyebolt (7) and nut (8).
12. Install spring (6) on eyebolt (7).





---

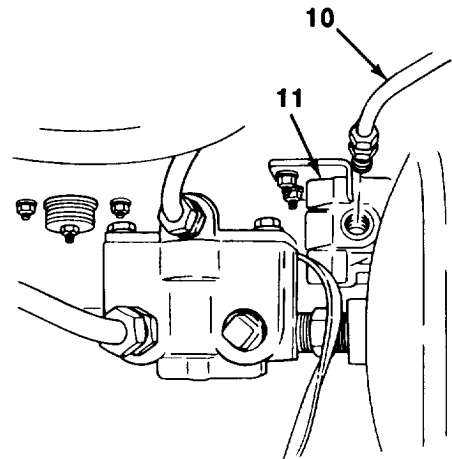
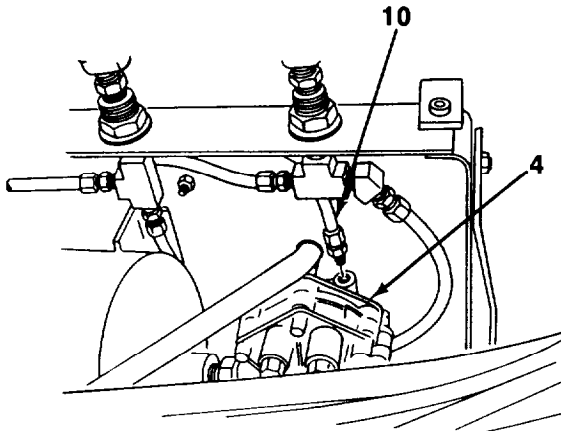
**4-73. REAR DOLLY AIR LINES REPLACEMENT (Con't).**

---

**b. FULL FUNCTION VALVE-TO-RELAY VALVE TUBE ASSEMBLY REPLACEMENT****CAUTION**

DO NOT overtighten fittings at full function valve and relay valve or damage to full function valve and relay valve will occur.

1. Disconnect tube assembly (10) from full function valve (4).
2. Disconnect tube assembly (10) from relay valve (11). Remove tube assembly.
3. Connect tube assembly (10) to relay valve (11).
4. Connect tube assembly (10) to full function valve (4).



---

## 4-73. REAR DOLLY AIR LINES REPLACEMENT (Con't).

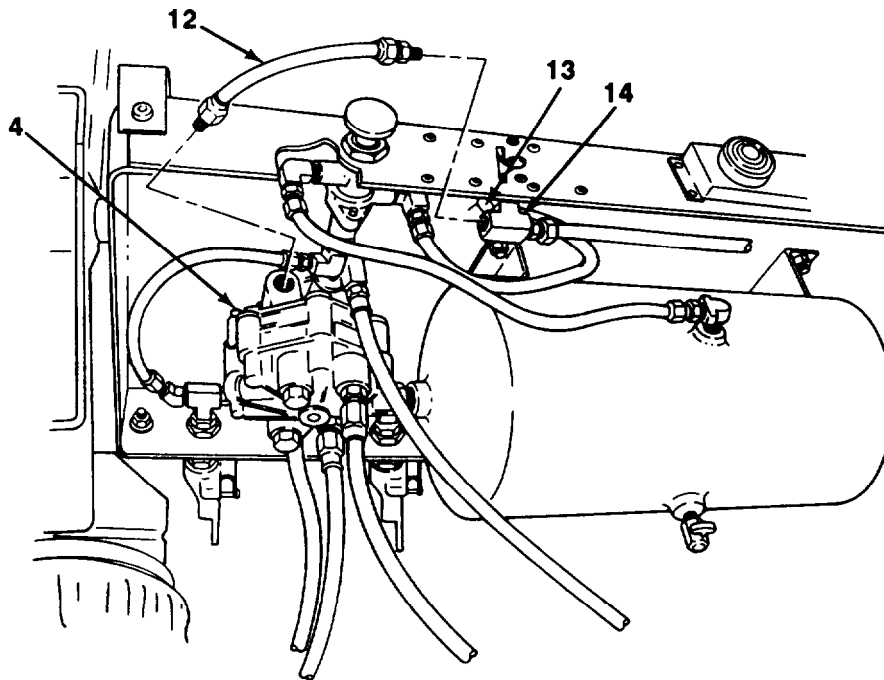
---

### c. FULL FUNCTION VALVE-TO-PARKING BRAKE VALVE TUBE ASSEMBLY REPLACEMENT

#### CAUTION

DO NOT overtighten fittings at full function valve and parking brake valve or damage to full function valve and parking brake valve will occur.

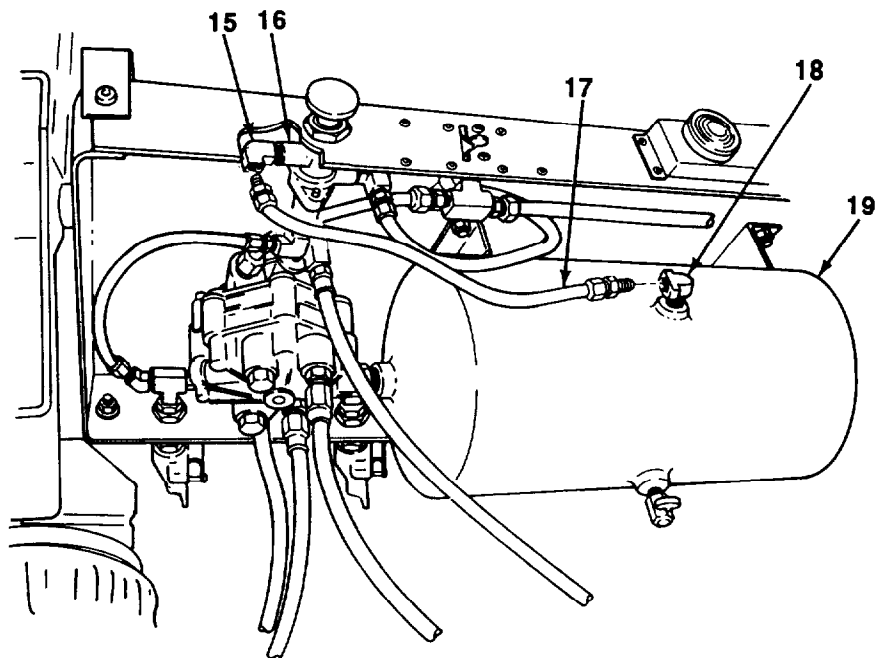
1. Disconnect tube assembly (12) from tee (14) at parking brake valve (13).
2. Disconnect tube assembly (12) from full function valve (4). Remove tube assembly.
3. Connect tube assembly (12) to full function valve (4).
4. Connect tube assembly (12) to tee (14).



### d. AIRBRAKE VALVE-TO-AIR RESERVOIR TUBE ASSEMBLY REPLACEMENT

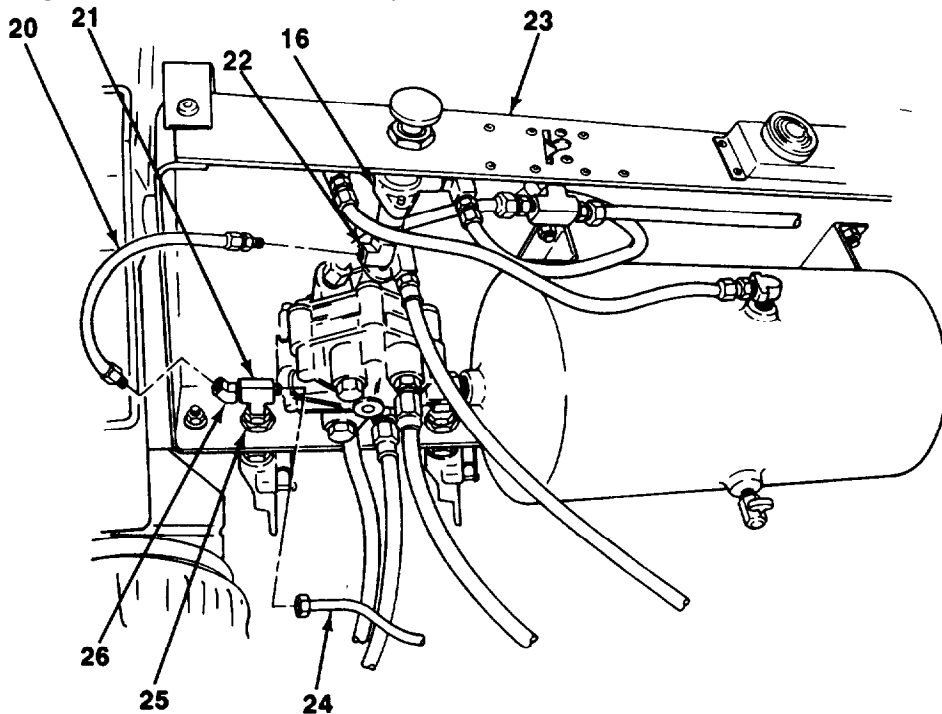
1. Disconnect tube assembly (17) from elbow (15) at airbrake valve (16).
2. Disconnect tube assembly (17) from elbow (18) at air reservoir (19). Remove tube assembly.
3. If damaged, remove elbow (18) from air reservoir (19).
4. If removed, install elbow (18) on air reservoir (19).
5. Connect tube assembly (17) to elbow (18).
6. Connect tube assembly (17) to elbow (15).

**4-73. REAR DOLLY AIR LINES REPLACEMENT (Con't).**



**e. AIRBRAKE VALVE-TO-TEE TUBE ASSEMBLY REPLACEMENT**

1. Disconnect tube assembly (20) from elbow (26) on left side of pivoting tray (23).
2. Disconnect tube assembly (20) from elbow (22) at airbrake valve (16). Remove tube assembly.
3. If tee (21) is damaged, disconnect tube assembly (24) from tee. Remove elbow (26) and tee from anchor coupling (25).

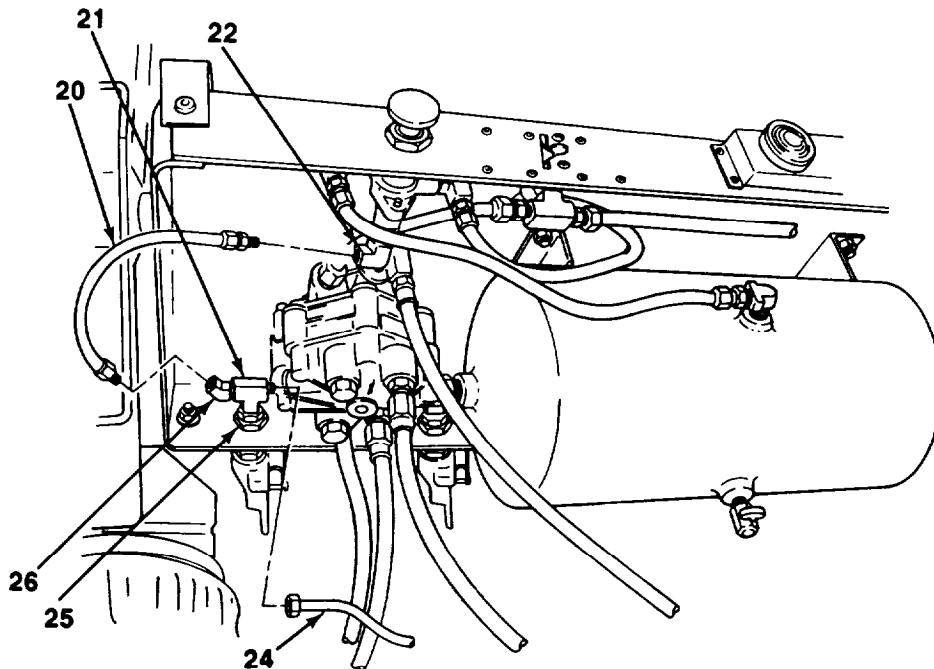


---

**4-73. REAR DOLLY AIR LINES REPLACEMENT (Con't).**

---

4. If removed, install tee (21) and elbow (26) to anchor coupling (25). Connect tube assembly (24) to tee.
5. Connect tube assembly (20) to elbow (22).
6. Connect tube assembly (20) to elbow (26).



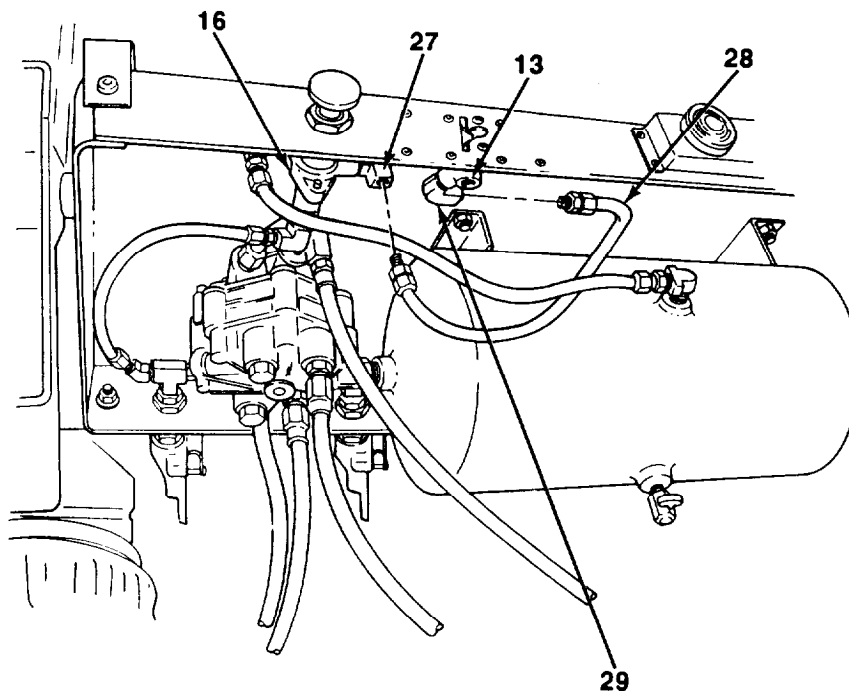
**f. AIRBRAKE VALVE-TO-PARKING BRAKE VALVE TUBE ASSEMBLY REPLACEMENT**

**CAUTION**

DO NOT overtighten fittings at parking brake valve or damage to parking brake valve will occur.

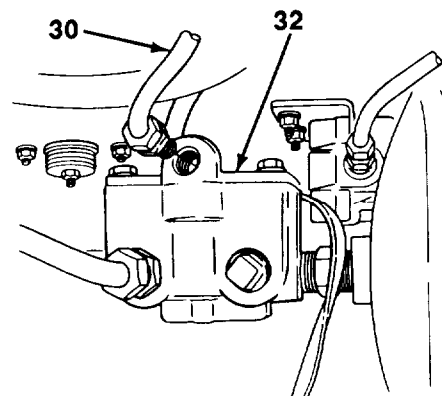
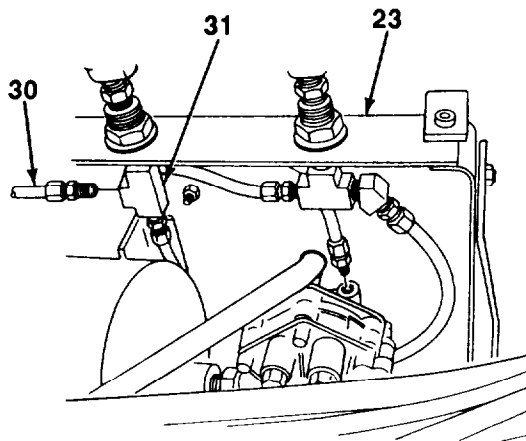
1. Disconnect tube assembly (28) from elbow (27) at airbrake valve (16).
2. Disconnect tube assembly (28) from elbow (29) at parking brake valve (13). Remove tube assembly.
3. Connect tube assembly (28) to elbow (29).
4. Connect tube assembly (28) to elbow (27).

4-73. REAR DOLLY AIR LINES REPLACEMENT (Con't).



**g. BOOSTER RELAY VALVE-TO-TEE TUBE ASSEMBLY REPLACEMENT**

1. Disconnect tube assembly (30) from tee (31) at pivoting tray (23).
2. Disconnect tube assembly (30) from booster relay valve (32). Remove tube assembly.
3. Connect tube assembly (30) to booster relay valve (32).
4. Connect tube assembly (30) to tee (31).



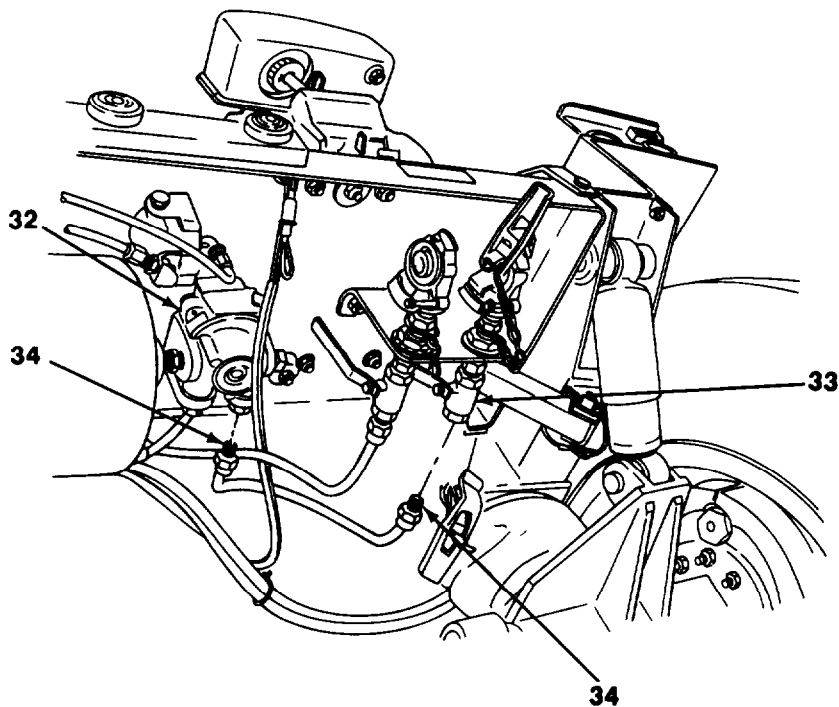
---

**4-73. REAR DOLLY AIR LINES REPLACEMENT (Con't).**

---

**h. BOOSTER RELAY VALVE-TO-RIGHT SIDE (SERVICE) SHUTOFF VALVE  
TUBE ASSEMBLY REPLACEMENT**

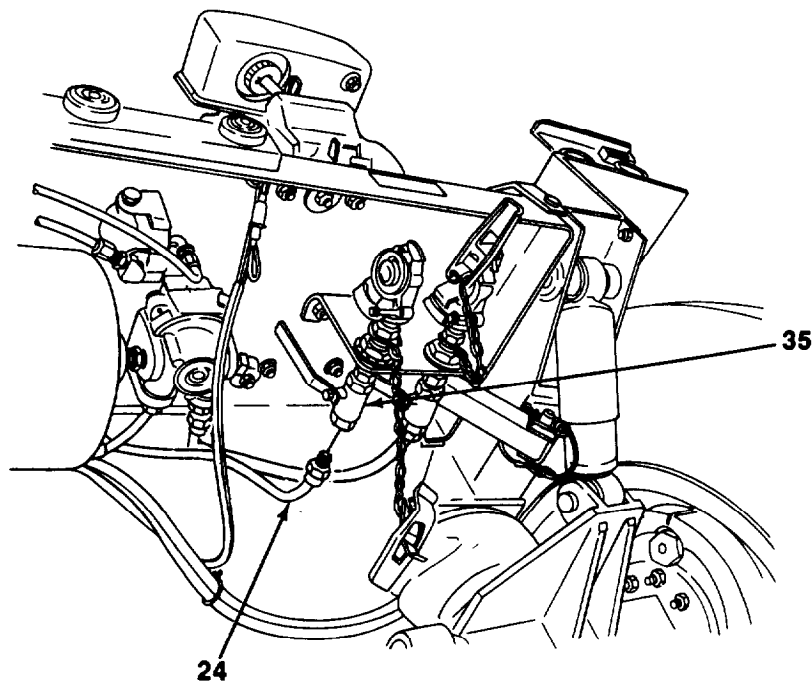
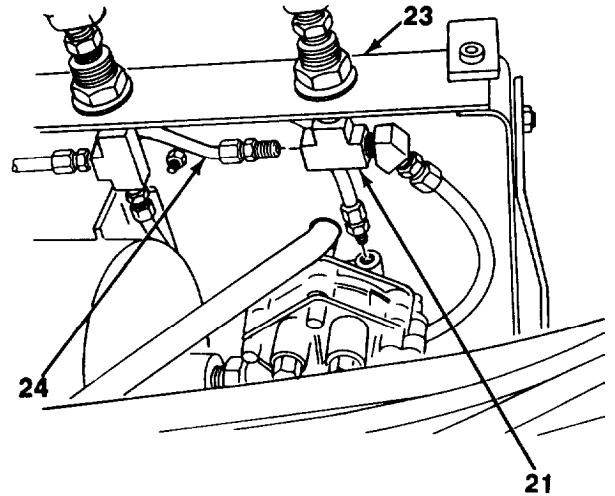
1. Disconnect tube assembly (34) from booster relay valve (32).
2. Disconnect tube assembly (34) from right side (service) shutoff valve (33). Remove tube assembly.
3. Connect tube assembly (34) to right side (service) shutoff valve (33).
4. Connect tube assembly (34) to booster relay valve (32).



**4-73. REAR DOLLY AIR LINES REPLACEMENT (Con't).**

**i. LEFT SIDE (EMERGENCY) SHUTOFF VALVE-TO-TEE TUBE ASSEMBLY REPLACEMENT**

1. Disconnect tube assembly (24) from tee (21) on left side of pivoting tray (23).
2. Disconnect tube assembly (24) from left side (emergency) shutoff valve (35). Remove tube assembly.
3. Connect tube assembly (24) to left side (emergency) shutoff valve (35).
4. Connect tube assembly (24) to tee (21).



---

**4-73. REAR DOLLY AIR LINES REPLACEMENT (Con't).**

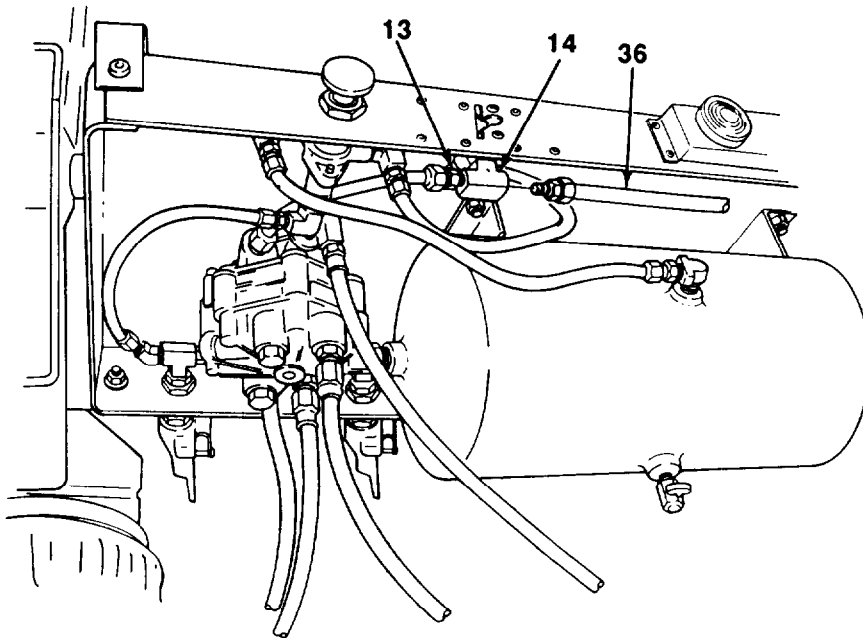
---

**i. RELAY VALVE-TO-PARKING BRAKE VALVE TUBE ASSEMBLY REPLACEMENT**

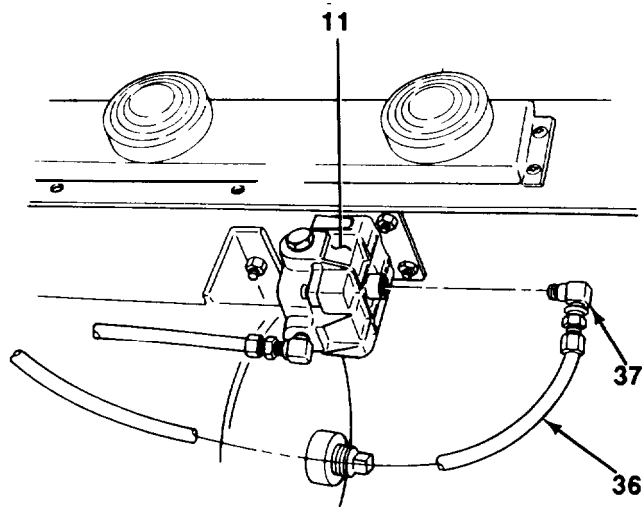
**CAUTION**

DO NOT overtighten fittings at relay valve and parking brake valve or damage to relay valve and parking brake valve will occur.

1. Disconnect tube assembly (36) from tee (14) at parking brake valve (13).
2. Disconnect tube assembly (36) from elbow (37) at relay valve (11). Remove tube assembly.



3. Connect tube assembly (36) to elbow (37).
4. Connect tube assembly (36) to tee (14).





---

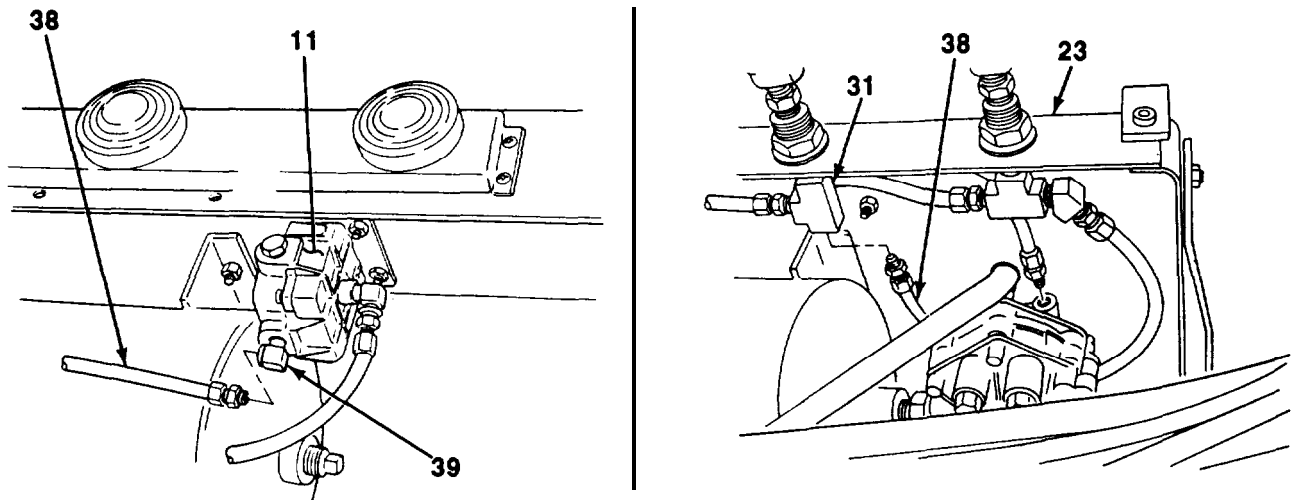
**4-73. REAR DOLLY AIR LINES REPLACEMENT (Con't).**


---

**k. RELAY VALVE-TO-TEE TUBE ASSEMBLY REPLACEMENT**
**CAUTION**

DO NOT overtighten fittings at relay valve or damage to relay valve will occur.

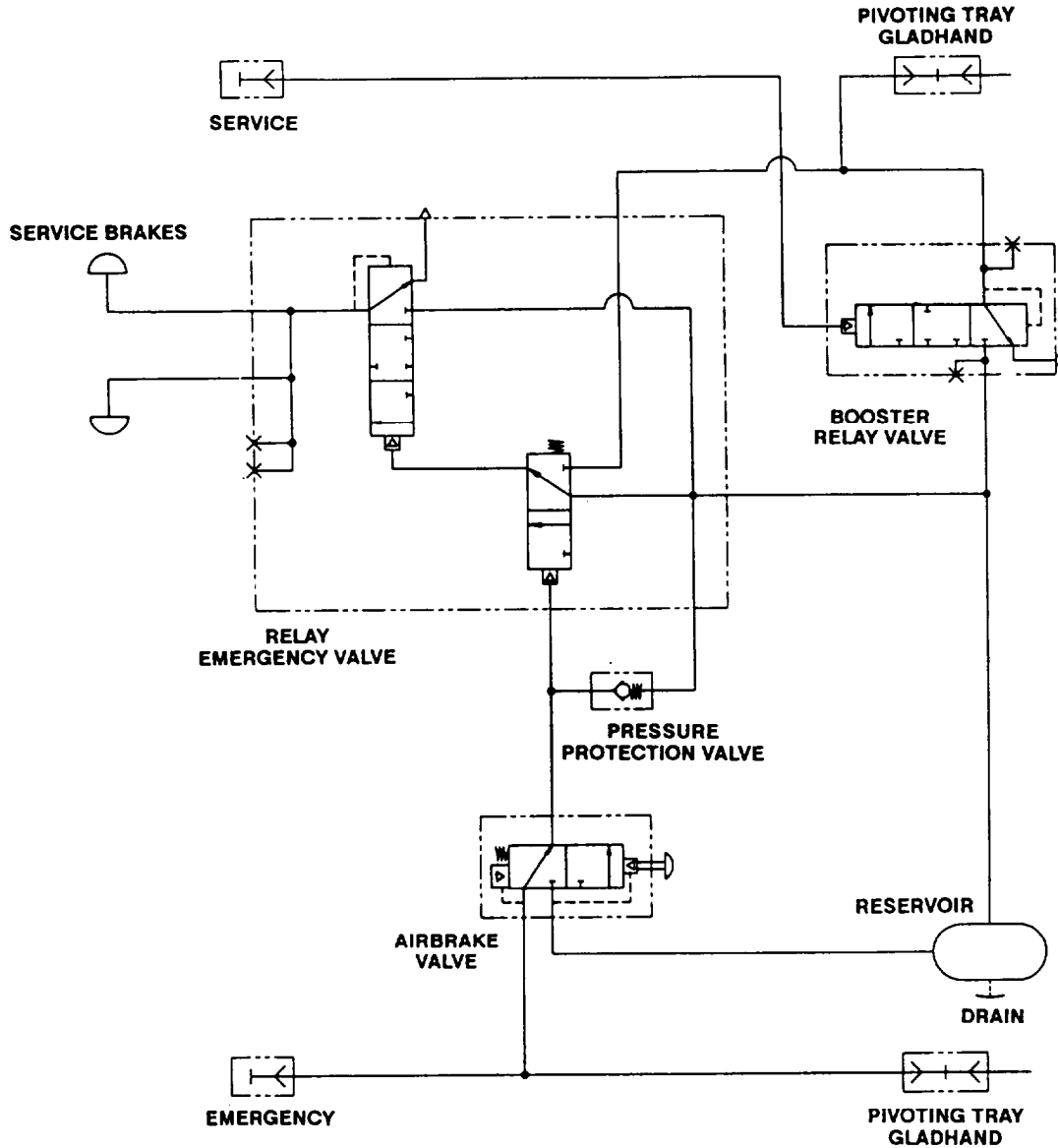
1. Disconnect tube assembly (38) from elbow (39) at relay valve (11).
2. Disconnect tube assembly (38) from tee (31) at front of pivoting tray (23). Remove tube assembly.
3. Connect tube assembly (38) to tee (31).
4. Connect tube assembly (38) to elbow (39).


Follow-on Tasks:

- Close air reservoir draincock (see paragraph 3-6).
- Connect intervehicular air hoses (see paragraph 2-11).
- Check for leaks (see paragraph 4-23).

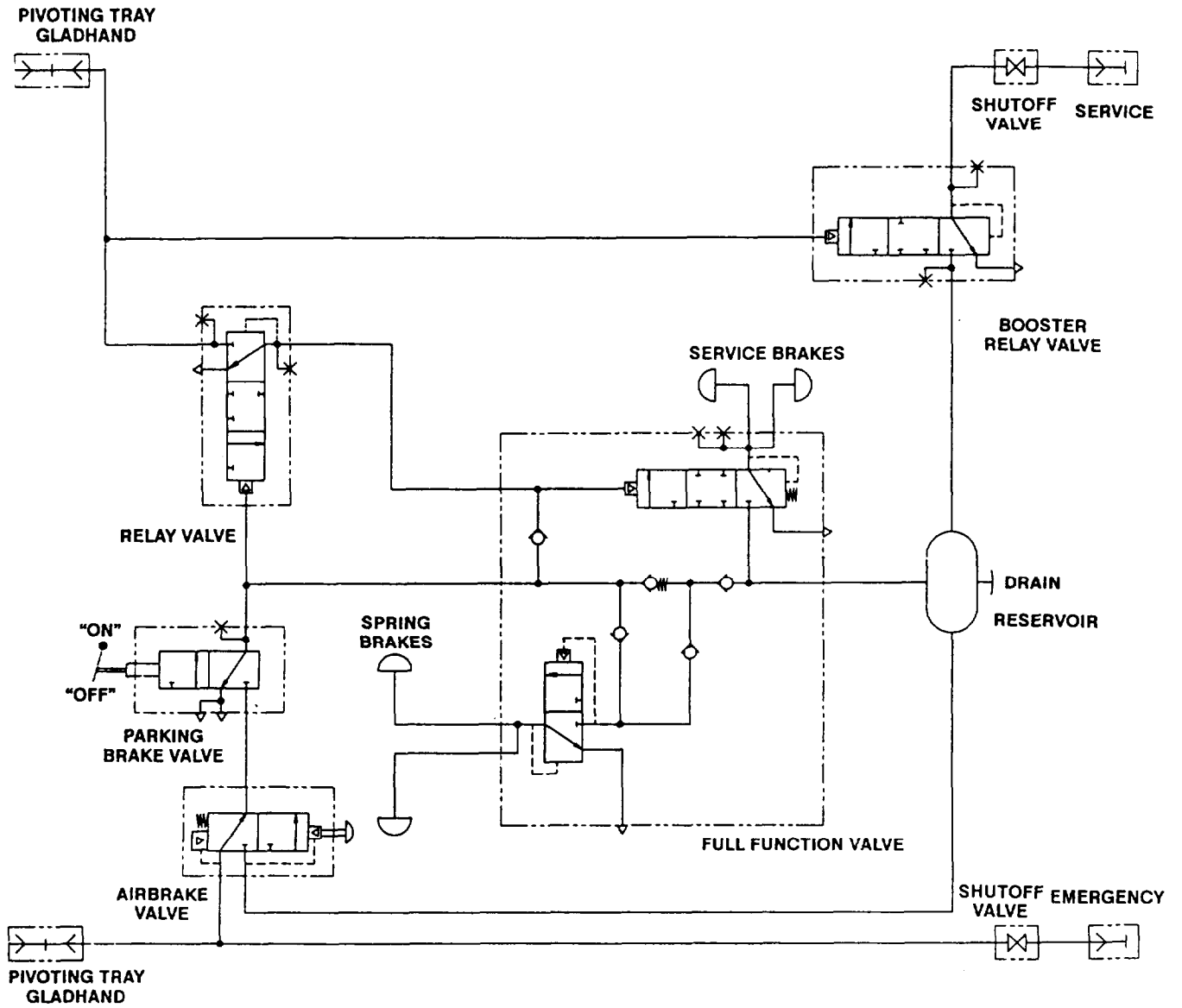
4-74. AIRBRAKE SYSTEM SCHEMATICS.

The following schematics show the front and rear dolly airbrake system components and their interrelationship.



FRONT DOLLY

4-74. AIRBRAKE SYSTEM SCHEMATICS (Con't).



REAR DOLLY



**Section IX. WHEEL, BRAKEDRUM, AND TIRE MAINTENANCE**

Paragraph Number	Paragraph Title	Page Number
4-75.	Hub, Brakedrum, and Wheel Bearings Maintenance. ....	4-191
4-76.	Wheel and Tire Maintenance .....	4-197

**4-75. HUB, BRAKEDRUM, AND WHEEL BEARINGS MAINTENANCE.**

This Task Covers:

- |                            |                             |
|----------------------------|-----------------------------|
| a. Removal                 | d. Assembly                 |
| b. Disassembly             | e. Installation             |
| c. Cleaning and Inspection | f. Wheel Bearing Adjustment |

Initial Setup:

Equipment Conditions:

- Brakes caged (rear dolly) (see paragraph 4-56).
- Tire and wheel removed (see paragraph 4-76).

Tools/Test Equipment:

- General mechanic's tool kit (Item 30, Appendix G)
- Socket wrench set, 3/4 in. drive, wheel bearing (Item 38, Appendix G)
- Torque wrench, 0-175 lb.-ft. (Item 42, Appendix G)
- Suitable lifting device

References:

- TM 9-214

Materials/Parts:

- Crocus cloth (Item 6, Appendix F)
- Grease (Item 19, Appendix F)
- Rags (Item 25, Appendix F)
- Dry cleaning solvent (Item 27, Appendix F)
- One O-ring
- One seal
- Eight lockwashers

Personnel Required: Two

General Safety Instructions:

- Dry cleaning solvent is flammable and must not be used near an open flame. Use only in a well-ventilated area.

---

**4-75. HUB, BRAKEDRUM, AND WHEEL BEARINGS MAINTENANCE (Con't).**

---

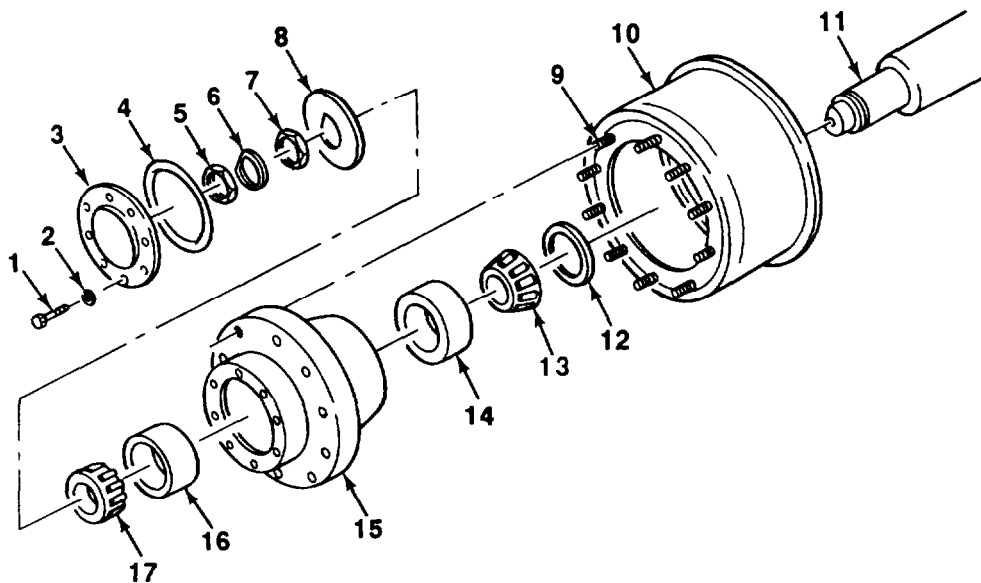
**a. REMOVAL**

1. Remove eight capscrews (1) lockwashers (2), cover plate (3), and O-ring (4) from hub (15). Discard lockwashers and O-ring.

NOTE

Lockwasher may be reused If not damaged.

2. Remove outer nut (5) lockwasher (6), inner nut (7) and washer (8) from spindle (11).



**WARNING**

Use extreme caution when handling heavy parts. Lifting device is required when parts weigh over 50 lb (23 kg) for a single person lift, over 100 lb (45 kg) for a two person lift, and over 150 lb (68 kg) for a three or more person lift. Keep clear of heavy parts supported only by lifting device. Failure to follow this warning may cause serious injury or death to personnel.

3. Remove hub (15) and brakedrum (10), as an assembly, and outer bearing cone (17) from spindle (11).
4. Remove seal (12) and inner bearing cone (13) from hub (15). Discard seal.

---

**4-75. HUB, BRAKEDRUM, AND WHEEL BEARINGS MAINTENANCE (Con't).**

---

**b. DISASSEMBLY****WARNING**

Use extreme caution when handling heavy parts. Lifting device is required when parts weigh over 50 lb (23 kg) for a single person lift, over 100 lb (45 kg) for a two person lift, and over 150 lb (68 kg) for a three or more person lift. Keep clear of heavy parts supported only by lifting device. Failure to follow this warning may cause serious injury or death to personnel.

1. Remove inner and outer bearing cups (14 and 16) from hub (15).
2. Remove ten studs (9) and separate hub (15) and brakedrum (10).

**c. CLEANING AND INSPECTION**

Dry cleaning solvent, P-D-680, is toxic and flammable. Always wear protective goggles and gloves, and use only in a well-ventilated area. Avoid contact with skin, eyes, and clothes, and DO NOT breathe vapors. DO NOT use near open flame or excessive heat. The solvent's flash point is 100°F-138°F (38°C-59°C). If you become dizzy while using cleaning solvent, immediately get fresh air and medical help. If solvent contacts eyes, immediately wash your eyes and seek medical attention.

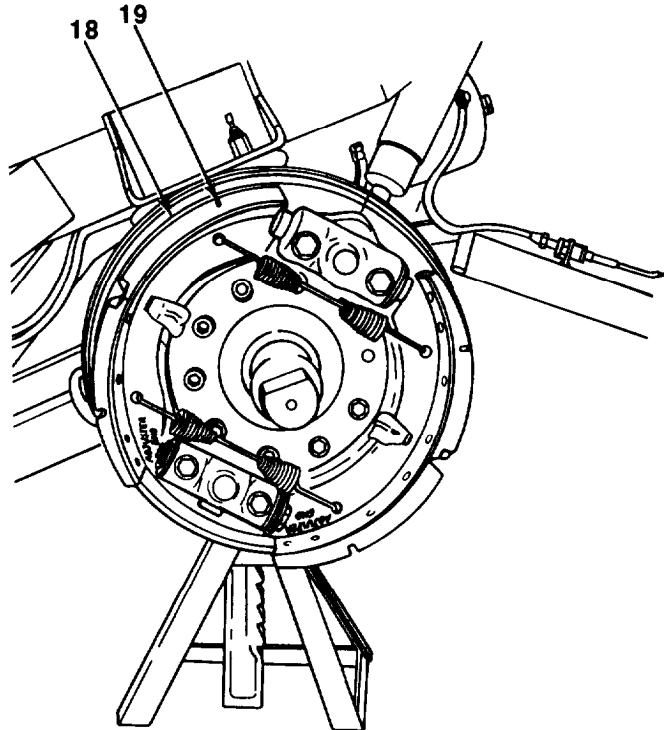
1. Clean and inspect bearing cones and bearing cups in accordance with TM 9-214. If any bearing cone or bearing cup is damaged, all bearing cones and bearing cups must be replaced.
2. Clean all other components and spindle with dry cleaning solvent and dry with a clean rag.

---

**4-75. HUB, BRAKEDRUM, AND WHEEL BEARINGS MAINTENANCE (Con't).**

---

3. Inspect brakeshoes (18) for cracks, looseness of linings or rivets, and wear. If linings are worn flat on wear notch (19) in middle of lining, a thickness equal to or less than 5/8 in. (7.94 mm), replace brakeshoes (see paragraph 4-57).
4. Inspect brakedrum for cracks, scoring, pitting, or grooves. Check edge of brakedrum for cracks or broken areas. Replace damaged brakedrum.
5. Inspect hub for cracks, breaks, or damage. Replace damaged hub.
6. Inspect spindle for burrs. Remove burrs with crocus cloth, clean with dry cleaning solvent, and dry with a clean rag.



**d. ASSEMBLY**

1. Install inner and outer bearing cups (14 and 16) squarely onto hub (15) until flush against shoulder.

**WARNING**

- Use extreme caution when handling heavy parts. Lifting device is required when parts weigh over 50 lb (23 kg) for a single person lift, over 100 lb (45 kg) for a two person lift, and over 150 lb (68 kg) for a three or more person lift. Keep clear of heavy parts supported only by lifting device. Failure to follow this warning may cause serious injury or death to personnel.
- Studs are marked LEFT-HAND and RIGHT-HAND. Left-hand studs must be installed on brakedrums on left side of dolly. Right-hand studs must be installed on brakedrums on right side of dolly. Failure to follow this warning may cause wheel nuts to loosen when dolly set is towed, resulting in injury to personnel.

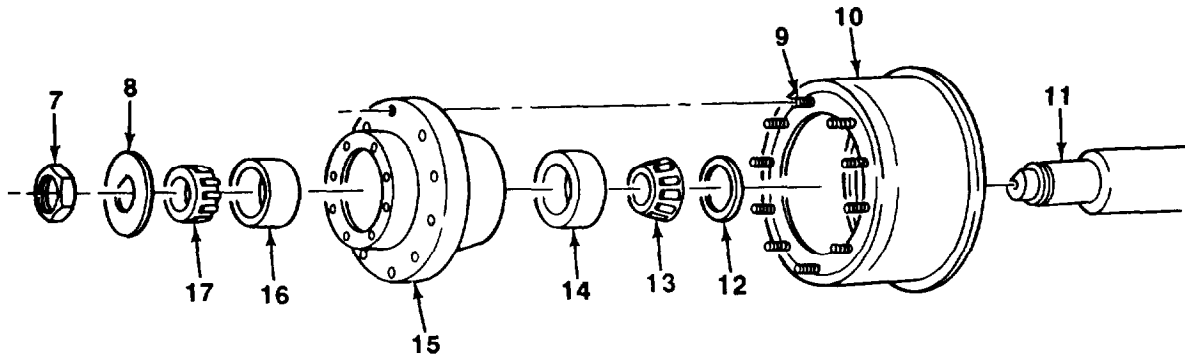
2. Assemble hub (15) and brakedrum (10) with ten studs (9).



---

**4-75. HUB, BRAKEDRUM, AND WHEEL BEARINGS MAINTENANCE (Con't).**


---


**e. INSTALLATION**

1. Pack inner bearing cone (13) with grease and install in hub (15). Install new seal (12).

**WARNING**

Use extreme caution when handling heavy parts. Lifting device is required when parts weigh over 50 lb (23 kg) for a single person lift, over 100 lb (45 kg) for a two person lift, and over 150 lb (68 kg) for a three or more person lift. Keep clear of heavy parts supported only by lifting device. Failure to follow this warning may cause serious injury or death to personnel.

**CAUTION**

Use caution not to damage seal.

2. Install hub (15) and brakedrum (10) on spindle (11).
3. Pack outer bearing cone (17) with grease and install on spindle (11).
4. Install washer (8) and inner nut (7) on spindle (11).

---

## 4-75. HUB, BRAKEDRUM, AND WHEEL BEARINGS MAINTENANCE (Con't).

---

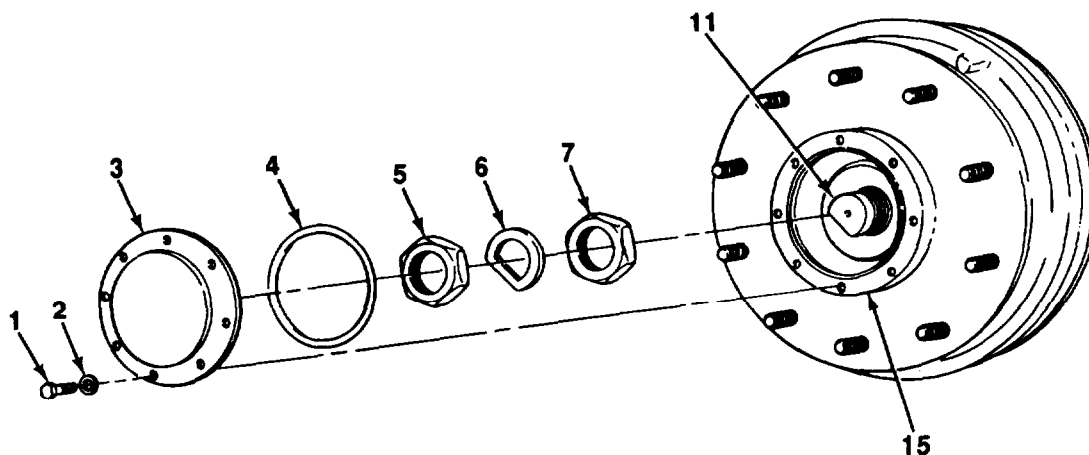
### f. WHEEL BEARING ADJUSTMENT

1. Tighten inner nut (7) while rotating wheel in both directions until wheel drags slightly. Back off inner nut until wheel spins freely and there is no looseness felt when wheel is rocked.

#### NOTE

If reusing lockwasher, ensure that it is flattened before installing.

2. Install lockwasher (6) and outer nut (5) on spindle (11). Torque outer nut to 100 lb.-ft. (136 N•m).
3. Bend tab on lockwasher (6) over inner nut (7).
4. Install new O-ring (4) in groove in hub (15).
5. Install cover plate (3) on hub (15) with eight new lockwashers (2) and capscrews (1).



#### Follow-on Tasks:

- Uncage brakes (rear dolly) (see paragraph 4-56).
- Install tire and wheel (see paragraph 4-76).
- Perform minor brake adjustment (see paragraph 4-59).

---

## 4-76. WHEEL AND TIRE MAINTENANCE.

---

*This Task Covers:*

- |            |                 |
|------------|-----------------|
| a. Removal | c. Installation |
| b. Repair  |                 |

---

*Initial Setup:*

**Equipment Conditions:**

- Parking brake lever set to ON position (see paragraph 2-2).

**Personnel Required:** Two

**References:**

- TM 9-2610-200-14

**Tools/Test Equipment:**

- General mechanic's tool kit (Item 30, Appendix G)
  - Hydraulic jack, 12 ton (Item 17, Appendix G)
  - Trestle (Item 32, Appendix G)
  - Socket wrench set, 3/4 in. drive (Item 39, Appendix G)
  - Torque wrench, 0-600 lb.-ft. (Item 43, Appendix G)
- 

**WARNING**

Use extreme caution when handling heavy parts. Lifting device is required when parts weigh over 50 lb (23 kg) for a single person lift, over 100 lb (45 kg) for a two person lift, and over 150 lb (68 kg) for a three or more person lift. Keep clear of heavy parts supported only by lifting device. Failure to follow this warning may cause serious injury or death to personnel.

**NOTE**

- Tires of the same manufacturer should be used on the same axle. If a replacement tire is of a different manufacturer than the other tire on the same axle, it is recommended that the other tire also be changed.
- Earlier model dolly set wheel and tires have tubes. Later model dolly set wheel and tires are tubeless. DO NOT mix tubed and tubeless tires on the same vehicle.

**a. REMOVAL**

**NOTE**

**Towing vehicle tire changing tools may be used.**

1. Chock wheel and tire on unaffected side.

---

## 4-76. WHEEL AND TIRE MAINTENANCE (Con't).

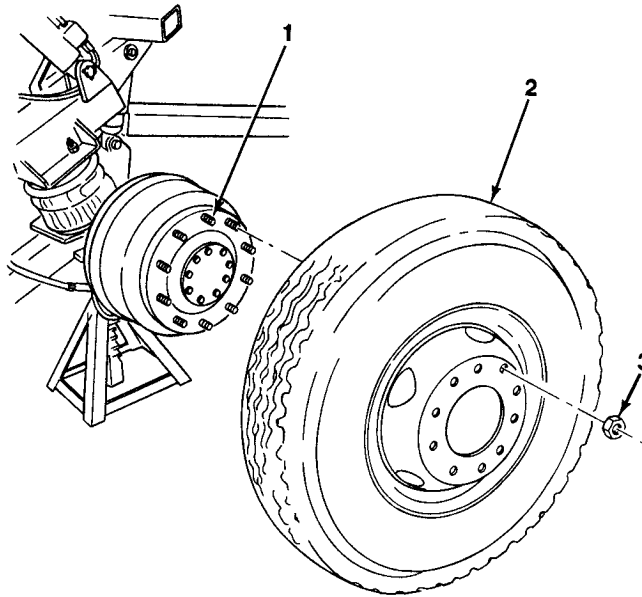
---

2. Loosen ten wheel nuts (3).

### NOTE

**Dolly set hydraulic control valve may be operated to raise wheel and tire off ground (see paragraph 2-21).**

3. Raise dolly set until wheel and tire (2) are off ground. Support with a trestle.
4. Remove ten wheel nuts (3) and wheel and tire (2) from studs (1).



**b. REPAIR**

**WARNING**

- **NEVER** reinflate a tire that has been run flat or seriously underinflated without first removing and repairing the tire and/or rim. Failure to follow this warning may result in serious injury or death to personnel.
- **Before removing tire for service and disassembly of rim components, ensure that tire is COMPLETELY deflated by removing valve stem. Failure to follow this warning may result in serious injury or death to personnel.**

Refer to TM 9-2610-200-14 for instructions on dismounting tire from wheel and repairing tube.

---

**4-76. WHEEL AND TIRE MAINTENANCE (Con't).**

---

**c. INSTALLATION**

1. Install wheel and tire (2) on studs (1).

**WARNING**

**Wheel nuts are left-hand and right-hand threaded. Left-hand wheel nuts must be installed on left-hand studs (left side of dolly). Right-hand wheel nuts must be installed on right-hand studs (right side of dolly). Failure to follow this warning may cause wheel nuts to loosen when dolly set is towed, resulting in Injury to personnel.**

2. Install ten wheel nuts (3) on studs (1) and tighten until snug.

**NOTE**

**Dolly set hydraulic control valve may be operated to lower wheel and tire to ground (see paragraph 2-21).**

3. Lower dolly set until wheel and tire (2) are on ground.
4. Evenly tighten ten wheel nuts (3) using a crisscross pattern. Torque wheel nuts in same crisscross pattern to 450-500 lb.-ft. (610-678 N•m).



**Section X. STEERING MAINTENANCE**

Paragraph Number	Paragraph Title	Page Number
4-77.	Tie-rod Assembly Maintenance .....	4-201
4-78.	Steering Link Replacement.....	4-206
4-79.	Steering Stop Replacement.....	4-209

**4-77. TIE-ROD ASSEMBLY MAINTENANCE.**

This Task Covers:

- |                            |              |
|----------------------------|--------------|
| a. Removal                 | d. Assembly  |
| b. Disassembly             | Installation |
| c. Cleaning and Inspection | f. Alinement |

Initial Setup:

Equipment Conditions:

- Dolly set raised and parked on a level surface.
- Parking brake lever set to ON position (see paragraph 2-2).
- Steering locking pin installed in steering link.

Tools/Test Equipment:

- General mechanic's tool kit (Item 30, Appendix G)
- Socket wrench adapter (Item 1, Appendix G)
- Crowfoot attachment (Item 5, Appendix G)
- Measuring tape (Item 28, Appendix G)
- Machinist's vise (Item 36, Appendix G)
- Adjustable wrench (Item 37, Appendix G)
- Torque wrench, 0-175 lb.-ft. (Item 42, Appendix G)

Materials/Parts:

- Sealing compound (Item 11, Appendix F)
- Rags (Item 25, Appendix F)
- Dry cleaning solvent (Item 27, Appendix F)
- Two grease fittings

General Safety Instructions:

- Dry cleaning solvent is flammable and must not be used near an open flame. Use only in a well-ventilated area.

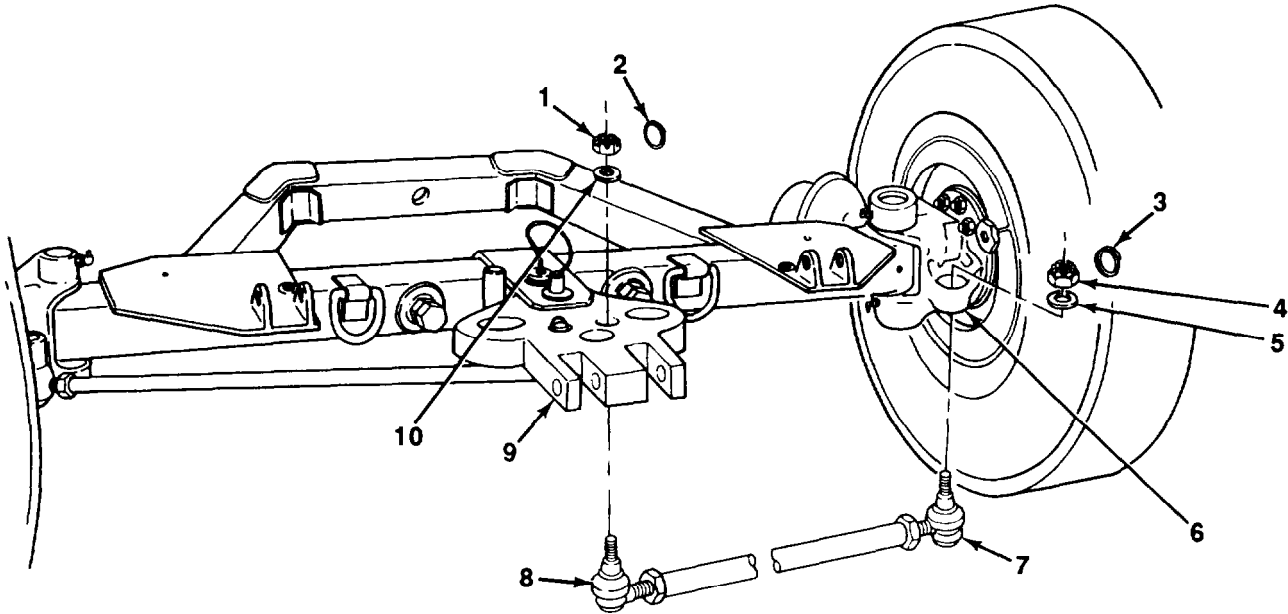
---

4-77. TIE-ROD ASSEMBLY MAINTENANCE (Con't).

---

**a. REMOVAL**

1. Remove circle cotter (3) hex castle nut (4) and flatwasher (5) from tie-rod end (7) at steering knuckle assembly (6).
2. Remove circle cotter (2), hex castle nut (1) and flatwasher (10) from tie-rod end (8) at steering link (9).



3. Remove tie-rod end (7) from steering knuckle assembly (6).
4. Remove tie-rod end (8) from steering link (9).

**b. DISASSEMBLY**

b. DISASSEMBLY

1. Secure tie-rod (13) in a vise.
2. Remove two grease fittings (11) from tie-rod ends (7 and 8). Discard grease fittings.



---

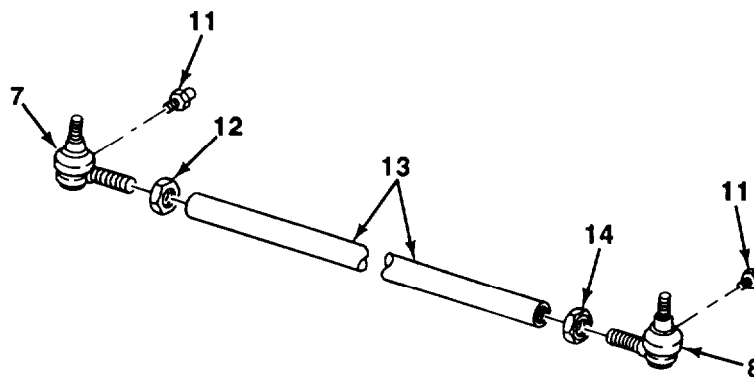
**4-77. TIE-ROD ASSEMBLY MAINTENANCE (Con't).**


---

## NOTE

Note number of threads showing on each tie-rod end to aid during assembly.

- Remove tie-rod ends (7 and 8) and jamnuts (12 and 14) from tie-rod (13).


**c. CLEANING AND INSPECTION**


Dry cleaning solvent, P-D-680, is toxic and flammable. Always wear protective goggles and gloves, and use only in a well-ventilated area. Avoid contact with skin, eyes, and clothes, and DO NOT breathe vapors. DO NOT use near open flame or excessive heat. The solvent's flash point is 100°F-138°F (38°C-59°C). If you become dizzy while using cleaning solvent, immediately get fresh air and medical help. If solvent contacts eyes, immediately wash your eyes and seek medical attention.

- Clean all metal components with dry cleaning solvent and dry with a clean rag.
- Inspect tie-rod for bends, cracks, and damaged threads. Replace damaged tie-rod.
- Inspect tie-rod ends for cracks, excessive looseness or play, wear, and damaged threads. Replace damaged tie-rod ends.

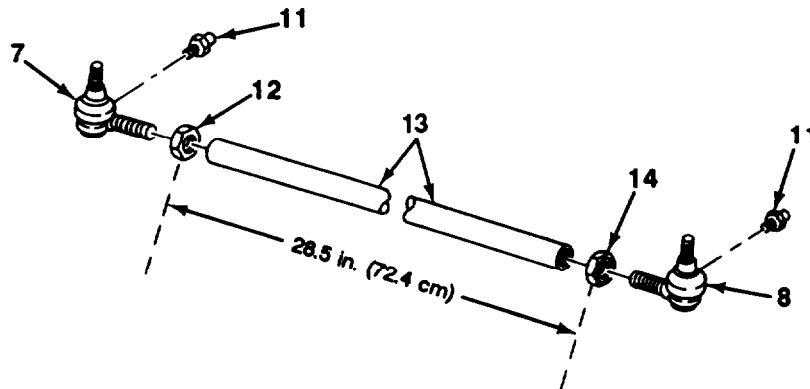
---

4-77. TIE-ROD ASSEMBLY MAINTENANCE (Con't).

---

**d. ASSEMBLY**

1. Secure tie-rod (13) in a vise.
2. Install jamnuts (12 and 14) and tie-rod ends (7 and 8) on tie-rod (13).



3. Adjust position of jamnuts (12 and 14) on tie-rod ends (7 and 8) as required to ensure that same number of threads are showing on tie-rod ends as noted during disassembly. When correctly assembled, tie-rod length from inner surface of jamnut (12) to inner surface of jamnut (14) is 28.5 in. (72.4 cm).
4. Install two new grease fittings (11) on tie-rod ends (7 and 8).

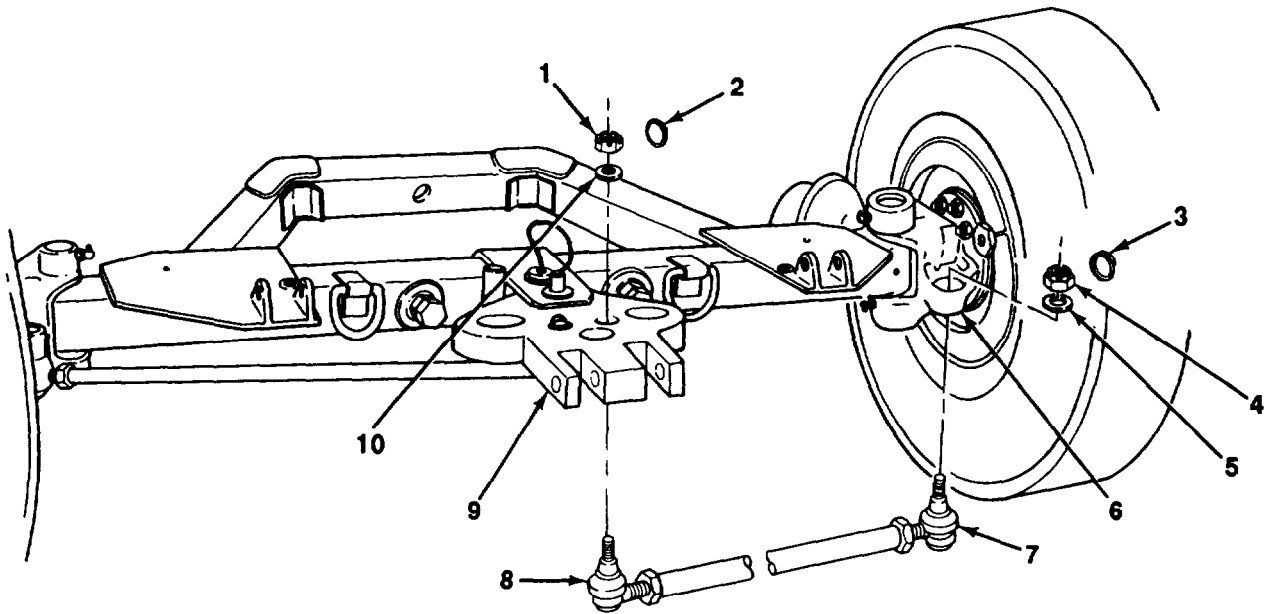
**e. INSTALLATION**

1. Install tie-rod ends (7 and 8) between steering knuckle assembly (6) and steering link (8) with grease fittings (11) outboard from axle.
2. Install flatwasher (10) and hex castle nut (1) on tie-rod end (8). Torque hex castle nut to 80-110 lb.-ft. (108-149 N•m).
3. Install flatwasher (5) and hex castle nut (4) on tie-rod end (7). Torque hex castle nut to 80-110 lb.-ft. (108-149 N•m).
4. Install circle cotters (2 and 3).

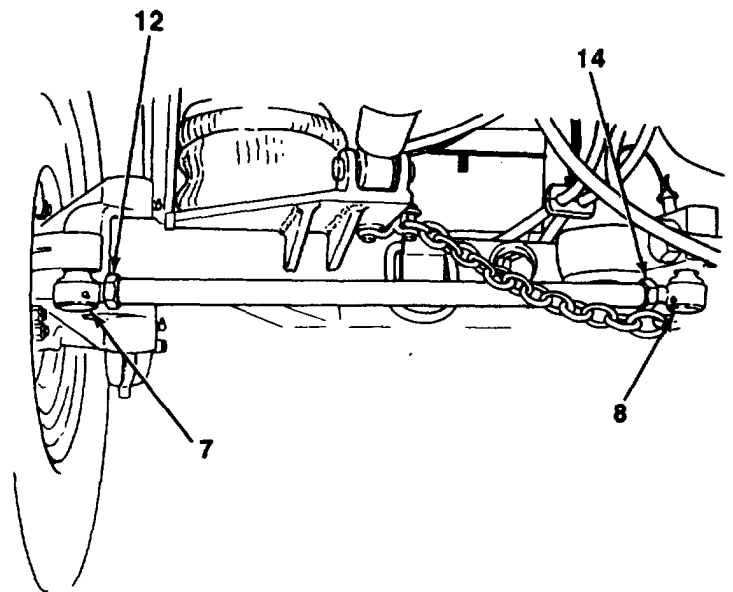
---

**4-77. TIE-ROD ASSEMBLY MAINTENANCE (Con't).**


---


**f. ALINEMENT**

1. Perform front axle alinement check (see paragraph 4-55).
2. If alinement is OK, loosen jamnuts (12 and 14). Apply sealing compound to threads of jamnuts and tie-rod ends (7 and 8). Tighten jamnuts and apply torque of 140 lb.-ft. (190 N•m).
3. If alinement is not OK, loosen jamnuts (12 and 14). Adjust jamnut position on tie-rod ends (7 and 8) as required. Repeat steps 1 and 2.


**Follow-on Tasks:**

- Remove steering locking pin from steering link.
- Lubricate tie-rod ends (see Lubrication Instructions, Chapter 3, Section I).

---

## 4-78. STEERING LINK REPLACEMENT.

---

This Task Covers:

- a. Removal
  - b. Cleaning and Inspection
  - c. Installation
- 

Initial Setup:

Equipment Conditions:

- Front drawbar removed (see paragraph 4-53).
- Tie-rod assemblies removed (see paragraph 4-77).

Tools/Test Equipment:

- General mechanic's tool kit (Item 30, Appendix G)

Materials/Parts:

- Rags (Item 25, Appendix F)
- Dry cleaning solvent (Item 27, Appendix F)
- One grease fitting
- One roll pin
- Two sleeves

General Safety Instructions:

- Dry cleaning solvent is flammable and must not be used near an open flame. Use only in a well-ventilated area.

Personnel Required: Two

---

**WARNING**

Use extreme caution when handling heavy parts. Lifting device is required when parts weigh over 50 lb (23 kg) for a single person lift, over 100 lb (45 kg) for a two person lift, and over 150 lb (68 kg) for a three or more person lift. Keep clear of heavy parts supported only by lifting device. Failure to follow this warning may cause serious injury or death to personnel.

**a. REMOVAL**

1. Remove steering locking pin (3) from front axle (1) and steering link (4).
2. Remove roll pin (6) center pin (2) and steering link (4) from front axle (1). Discard roll pin.
3. Remove grease fitting (5) from steering link (4). Discard grease fitting.

NOTE

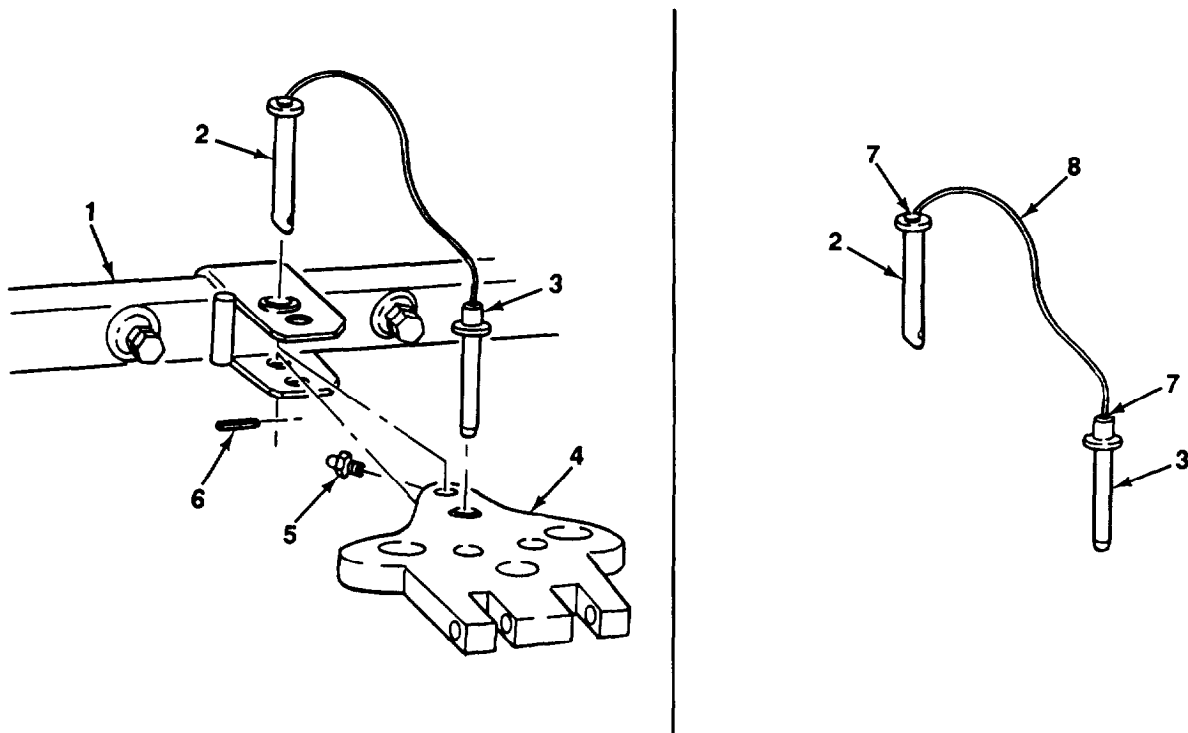
Perform step 4 to remove detent pin lanyard assembly from center pin and steering locking pin as required.

4. Cut lanyard cable (8) from ends of center pin (2) and steering locking pin (3). Discard sleeves (7).

---

**4-78. STEERING LINK REPLACEMENT (Con't).**


---


**b. CLEANING AND INSPECTION**


Dry cleaning solvent, P-D-680, is toxic and flammable. Always wear protective goggles and gloves, and use only in a well-ventilated area. Avoid contact with skin, eyes, and clothes, and DO NOT breathe vapors. DO NOT use near open flame or excessive heat. The solvent's flash point is 100°F-138°F (38°C-59°C). If you become dizzy while using cleaning solvent, immediately get fresh air and medical help. If solvent contacts eyes, immediately wash your eyes and seek medical attention.

1. Clean steering link with dry cleaning solvent and dry with a clean rag.
2. Inspect steering link for cracks, breaks, or damaged bushing surfaces. Replace damaged steering link.

**c. INSTALLATION**
**NOTE**

Perform step 1 to Install detent pin lanyard assembly to center pin and steering locking pin.

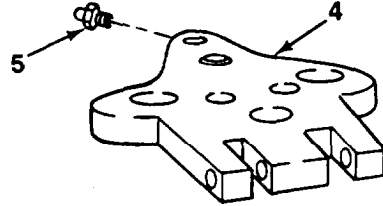
1. Thread lanyard cable (8) through ends of center pin (2) and steering locking pin (3). Secure each end with new sleeve (7). Crimp sleeves.

---

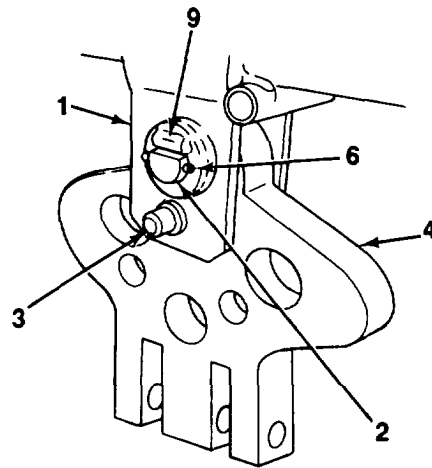
#### 4-78. STEERING LINK REPLACEMENT (Con't).

---

2. Install new grease fitting (5) on steering link (4).



3. Install steering link (4) on front axle (1) with notch in end of center pin (2) aligned with square portion of axle weldment (9). Install new roll pin (6) through center pin.
4. Secure steering link (4) in locked position with steering locking pin (3).



#### Follow-on Tasks:

- Lubricate steering link (see Lubrication Instructions, Chapter 3, Section I).
- Install tie-rod assemblies (see paragraph 4-77).
- Install front drawbar (see paragraph 4-63).

---

## 4-79. STEERING STOP REPLACEMENT.

---

*This Task Covers:*

- a. Removal b. Installation
- 

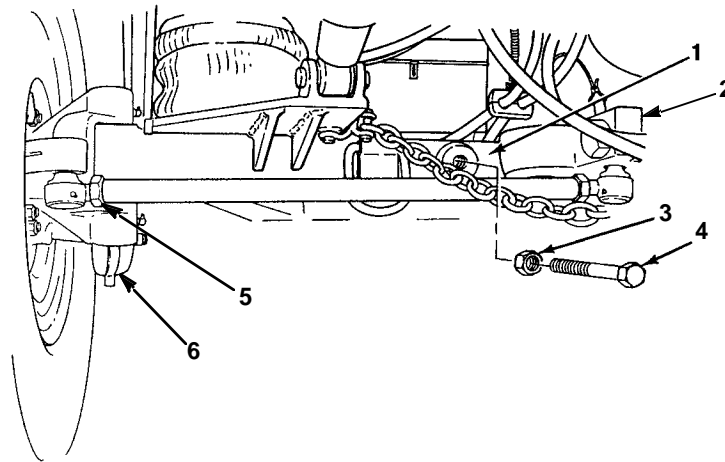
*Initial Setup:*

### Tools/Test Equipment:

- General mechanic's tool kit (Item 30, Appendix G)
  - Adjustable wrench (Item 37, Appendix G)
  - Socket wrench set, 3/4 in. drive (Item 39, Appendix G)
- 

#### a. REMOVAL

1. Loosen stop nut (3).
2. Remove stop bolt (4) from front axle (1).
3. Remove stop nut (3) from stop bolt (4).



#### b. INSTALLATION

1. Install stop nut (3) on stop bolt (4).
2. Install stop bolt (4) on front axle (1) so that distance from front face of boss to top of stop bolt head is approximately 1.50 in. (3.81 cm).
3. Turn steering to position center steering link (2) against stop bolt (4) head. Adjust stop bolt to provide a 0.12 in. (0.3 cm) clearance between airbrake chamber (6) and aft side of axle air bag mounting plate.

#### NOTE

**Check that tie rod end jamnut (5) does not contact steering knuckle.**

4. Tighten stop nut (3).





**Section XI. FRAME AND TOWING ATTACHMENTS MAINTENANCE**

Paragraph Number	Paragraph Title	Page Number
4-80.	Front Dolly Pivoting Tray Replacement .....	4-212
4-81.	Rear Dolly Pivoting Tray Replacement .....	4-215
4-82.	Pivot Axle Bracket Replacement .....	4-218
4-83.	Top and Bottom Beams and Positioning Cylinders Replacement .....	4-222
4-84.	Top Hook Replacement .....	4-229
4-85.	Transportation Lockout Replacement .....	4-230
4-86.	Telescopic Brace Replacement .....	4-232
4-87.	Front Drawbar Dummy Coupling Replacement .....	4-234
4-88.	Rear Drawbar Replacement .....	4-235
4-89.	Rear Drawbar Pin Assembly Replacement .....	4-236
4-90.	Pintle Assembly Replacement .....	4-238
4-91.	Caster Wheel Assembly Maintenance .....	4-239
4-92.	Front Dolly Junction Box Bracket Replacement .....	4-242
4-93.	Front Dolly Hydraulic Control Valve Bracket Replacement .....	4-243
4-94.	Front Dolly Brace Replacement .....	4-244
4-95.	Rear Dolly Junction Box Bracket Replacement .....	4-245
4-96.	Rear Dolly Hydraulic Control Valve Bracket Replacement .....	4-246
4-97.	Toolbox Mounting Brackets Replacement .....	4-247
4-98.	Pivoting Tray Lockout Brace and Upper and Lower Brackets Replacement .....	4-248
4-99.	Lanyard Assemblies Replacement .....	4-250
4-100.	Hanger Bracket Replacement .....	4-253

---

## 4-80. FRONT DOLLY PIVOTING TRAY REPLACEMENT.

---

This Task Covers:

- a. Removal
  - b. Cleaning and Inspection
  - C. Installation
- 

Initial Setup:

Equipment Conditions:

- Front dolly air lines removed (see paragraph 4-72).
- Pivoting tray gladhands removed (see paragraph 4-71).
- Airbrake valve removed (see paragraph 4-65).
- Front dolly booster relay valve removed (see paragraph 4-63).
- Front dolly pressure protection valve removed (see paragraph 4-64).
- Front dolly relay emergency valve and air reservoir removed (see paragraph 4-62).
- Battery case removed (see paragraph 4-44).
- Hydraulic lines removed (see paragraph 4-109).
- Hydraulic reservoir and redundant power fittings removed (see paragraph 4-111).
- Engine removed (see paragraph 4-115).

Materials/Parts:

- Sealing compound (item 11, Appendix F)
- Dry cleaning solvent (Item 27, Appendix F)
- Eight locknuts

Tools/Test Equipment:

- General mechanic's tool kit (Item 30, Appendix G)
- Torque wrench, 0-175 lb.-ft. (Item 42, Appendix G)

Personnel Required: Two

General Safety Instructions:

- Dry cleaning solvent is flammable and must not be used near an open flame. Use only in a well-ventilated area.
- 

### **a. REMOVAL**

1. Remove two locknuts (9) and flatwashers (8) from bearing rods (6). Discard locknuts.
2. Remove pivoting tray (1) from two suspension link mounting brackets (7).
3. Remove two locknuts (3) flatwashers (4), and bearing rods (6) from brackets (2). Discard locknuts.
4. Remove two jamnuts (5) from bearing rods (6).
5. Remove four locknuts (10), flatwashers (11), shoulder screws (13), Flatwashers (12) and two brackets (2) from pivoting tray (1). Discard locknuts.

---

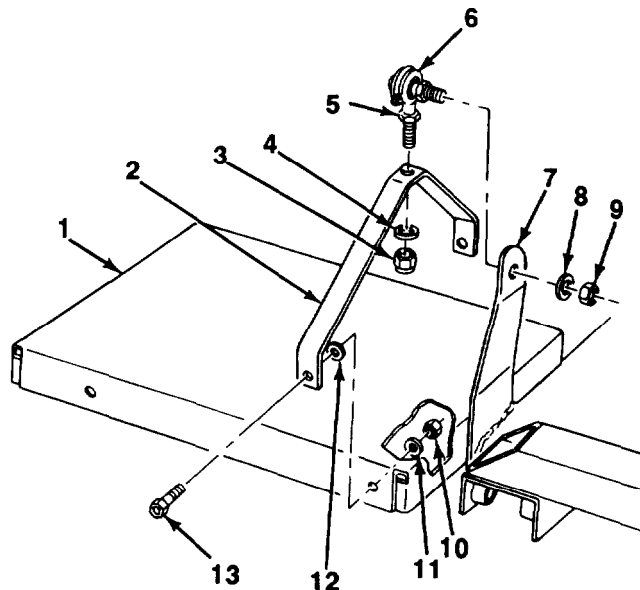
**4-80. FRONT DOLLY PIVOTING TRAY REPLACEMENT (Con't).**


---

**NOTE**

Perform steps 6 and 7 if components are damaged or if replacing pivoting tray.

6. Remove data plate (see paragraph 4-105).
7. Remove pivoting tray lockout brace and upper bracket (see paragraph 4-98).

**b. CLEANING AND INSPECTION**

Dry cleaning solvent, P-D-680, is toxic and flammable. Always wear protective goggles and gloves, and use only in a well-ventilated area. Avoid contact with skin, eyes, and clothes, and DO NOT breathe vapors. DO NOT use near open flame or excessive heat. The solvent's flash point is 100°F-138°F (38°C-59°C). If you become dizzy while using cleaning solvent, immediately get fresh air and medical help. If solvent contacts eyes, immediately wash your eyes and seek medical attention.

1. Clean all components with dry cleaning solvent and allow to dry.
2. Inspect all components for damage. Replace damaged components.

**c. INSTALLATION**

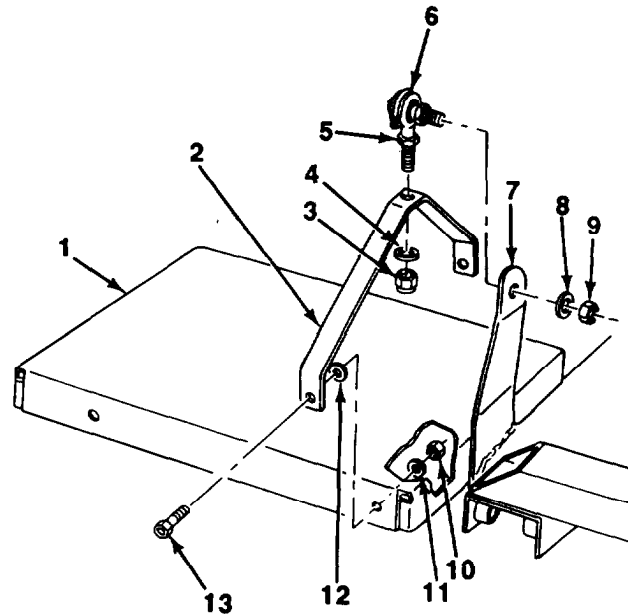
1. If removed, install pivoting tray upper bracket and lockout brace (see paragraph 4-98).
2. If removed, install data plate (see paragraph 4-105).

---

**4-80. FRONT DOLLY PIVOTING TRAY REPLACEMENT (Con't).**

---

3. Install two brackets (2) on pivoting tray (1) with four flatwashers (12), shoulder screws (13), flatwashers (11), and new locknuts (10).
4. Apply sealing compound to jamnuts (5). Fully install jamnuts on bearing rods (6) until bottomed out. Install bearing rods on brackets (2) with flatwashers (4) and new locknuts (3). Torque locknuts to 85 lb.-ft. (115 N•m).
5. Install pivoting tray (1) on two suspension link mounting brackets (7) with two bearing rods (6), flatwashers (8), and new locknuts (9). Torque locknuts to 25-30 lb.-ft. (34-41 N•m).



Follow-on Tasks:

- Install engine (see paragraph 4-115).
- install hydraulic reservoir and redundant power fittings (see paragraph 4-111).
- Install hydraulic lines (see paragraph 4-109).
- Install battery case assembly (see paragraph 4-44).
- Install front dolly relay emergency valve and air reservoir (see paragraph 4-62).
- Install front doily pressure protection valve (see paragraph 4-64).
- Install front dolly booster relay valve (see paragraph 4-63).
- Install airbrake valve (see paragraph 4-65).
- Install pivoting tray gladhands (see paragraph 4-71).
- Install front dolly air lines (see paragraph 4-72).
- Lubricate pivoting tray bearings (see Lubrication Instructions, Chapter 3, Sectlon I).

---

## 4-81. REAR DOLLY PIVOTING TRAY REPLACEMENT.

---

This Task Covers:

- |                            |                 |
|----------------------------|-----------------|
| a. Removal                 | c. Installation |
| b. Cleaning and Inspection |                 |
- 

Initial Setup:

Equipment Conditions:

- Identification light removed (see paragraph 4-42).
- Rear dolly air lines removed (see paragraph 4-73).
- Pivoting tray gladhands removed (see paragraph 4-71).
- Airbrake valve removed (see paragraph 4-65).
- Rear dolly parking brake valve removed (see paragraph 4-69).
- Rear dolly relay valve removed (see paragraph 4-70).
- Rear dolly booster relay valve removed (see paragraph 4-67).
- Rear dolly shutoff valves and mounting bracket removed (see paragraph 4-68).
- Rear dolly full function valve and air reservoir removed (see paragraph 4-66).
- Battery case removed (see paragraph 4-44).
- Hydraulic lines removed (see paragraph 4-109).
- Hydraulic reservoir and redundant power fittings removed (see paragraph 4-111).
- Engine removed (see paragraph 4-115).

Materials/Parts:

- Sealing compound (Item 11, Appendix F)
- Dry cleaning solvent (Item 27, Appendix F)
- Eight locknuts

Tools/Test Equipment:

- General mechanic's tool kit (Item 30, Appendix G)
- Torque wrench, 0-175 lb.-ft. (Item 42, Appendix G)

Personnel Required: Two

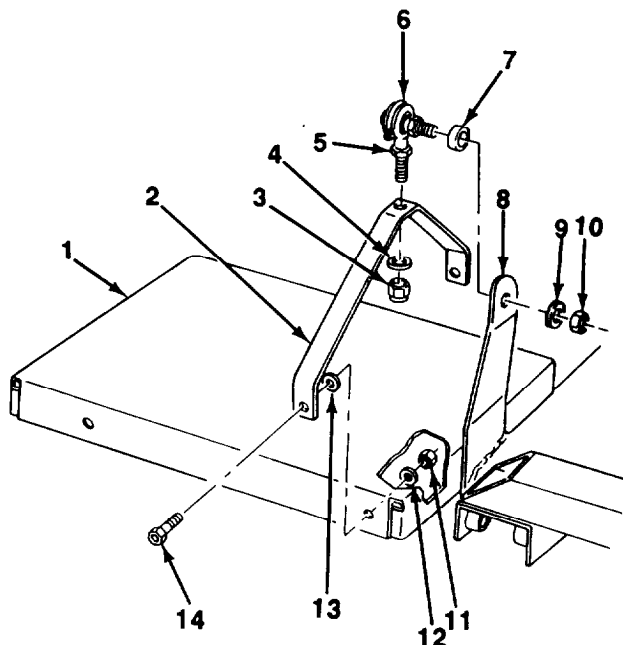
General Safety Instructions:

- Dry cleaning solvent is flammable and must not be used near an open flame. Use only in a well-ventilated area.
-

## 4-81. REAR DOLLY PIVOTING TRAY REPLACEMENT (Con't).

### a. REMOVAL

1. Remove two locknuts (10) and flatwashers (9) from bearing rods (6). Discard locknuts.
2. Remove pivoting tray (1) and two spacers (7) from suspension link mounting brackets (8).
3. Remove two locknuts (3), flatwashers (4), and bearing rods (6) from brackets (2). Discard locknuts.
4. Remove two jamnuts (5) from bearing rods (6).
5. Remove four locknuts (11), flatwashers (12), shoulder screws (14), flatwashers (13), and two brackets (2) from pivoting tray (1). Discard locknuts.



### NOTE

Perform steps 6 and 7 if components are damaged or if replacing pivoting tray.

6. Remove data plates (see paragraph 4-105).
7. Remove pivoting tray lockout brace and upper bracket (see paragraph 4-98).

### b. CLEANING AND INSPECTION



Dry cleaning solvent, P-D-680, is toxic and flammable. Always wear protective goggles and gloves, and use only in a well-ventilated area. Avoid contact with skin, eyes, and clothes, and DO NOT breathe vapors. DO NOT use near open flame or excessive heat. The solvent's flash point is 100°F-138°F (38°C-59°C). If you become dizzy while using cleaning solvent, Immediately get fresh air and medical help. If solvent contacts eyes, Immediately wash your eyes and seek medical attention.

1. Clean all components with dry cleaning solvent and allow to dry.
2. Inspect all components for damage. Replace damaged components.

---

**4-81. REAR DOLLY PIVOTING TRAY REPLACEMENT (Con't).**

---

**c. INSTALLATION**

1. If removed, install pivoting tray upper bracket and lockout brace (see paragraph 4-98).
2. If removed, install data plates (see paragraph 4-105).
3. Install two brackets (2) on pivoting tray (1) with four flatwashers (13), shoulder screws (14), flatwashers (12), and new locknuts (11).
4. Apply sealing compound to jamnuts (5). Fully install jamnuts on bearing rods (6) until bottomed out. install bearing rods on brackets (2) with flatwashers (4) and new locknuts (3). Torque locknuts to 85 lb.-ft. (115 N•m).
5. Install pivoting tray (1) on two suspension link mounting brackets (8) with two spacers (7), bearing rods (6), flatwashers (9), and new locknuts (10). Torque locknuts to 25-30 lb.-ft. (3441 N•m).

**Follow-on Tasks:**

- Install engine (see paragraph 4-115).
- Install hydraulic reservoir and redundant power fittings (see paragraph 4-111).
- Install hydraulic lines (see paragraph 4-109).
- Install battery case assembly (see paragraph 444).
- Install rear dolly full function valve and air reservoir (see paragraph 4-66).
- Install rear dolly mounting bracket and shutoff valves (see paragraph 4-68).
- Install rear dolly booster relay valve (see paragraph 4-67).
- Install rear dolly relay valve (see paragraph 4-70).
- Install rear dolly parking brake valve (see paragraph 4-69).
- Install airbrake valve (see paragraph 4-65).
- Install pivoting tray gladhands (see paragraph 4-71).
- Install rear dolly air lines (see paragraph 4-73).
- Install identification light (see paragraph 442).
- Lubricate pivoting tray bearings (see Lubrication Instructions, Chapter 3, Section I).

---

## 4-82. PIVOT AXLE BRACKET REPLACEMENT.

---

*This Task Covers:*

a. Removal

b. Installation

---

*Initial Setup:*

**Equipment Conditions:**

- Dolly set lowered, front and rear dollies detached (see paragraph 2-8).

**Tools/Test Equipment:**

- General mechanic's tool kit (Item 30, Appendix G)
- Adjustable wrench (Item 37, Appendix G)

**Tools/Test Equipment (Con't):**

- Suitable lifting device

**Materials/Parts:**

- Grease (Item 19, Appendix F)
- Two cotter pins

**Personnel Required:** Three

**WARNING**

**Use extreme caution when handling heavy parts. Lifting device is required when parts weigh over 50 lb (23 kg) for a single person lift, over 100 lb (45 kg) for a two person lift, and over 150 lb (68 kg) for a three or more person lift. Keep clear of heavy parts supported only by lifting device. Failure to follow this warning may cause serious injury or death to personnel.**

**a. REMOVAL**

**NOTE**

**Perform steps 5 and 6 only if removing pivot axle bracket lockout brackets.**

1. Use a suitable lifting device to support top beam (1).

**NOTE**

**On right side, hose assemblies are secured to both side and underside of suspension link.**

2. Remove self-tapping screw (5) flatwasher (4) hose clamp (3) and two hydraulic hose assemblies (6) from each suspension link (2).
3. Place a wooden block under midpoint of axle assembly (11) at attachment point of pivot axle bracket (18).

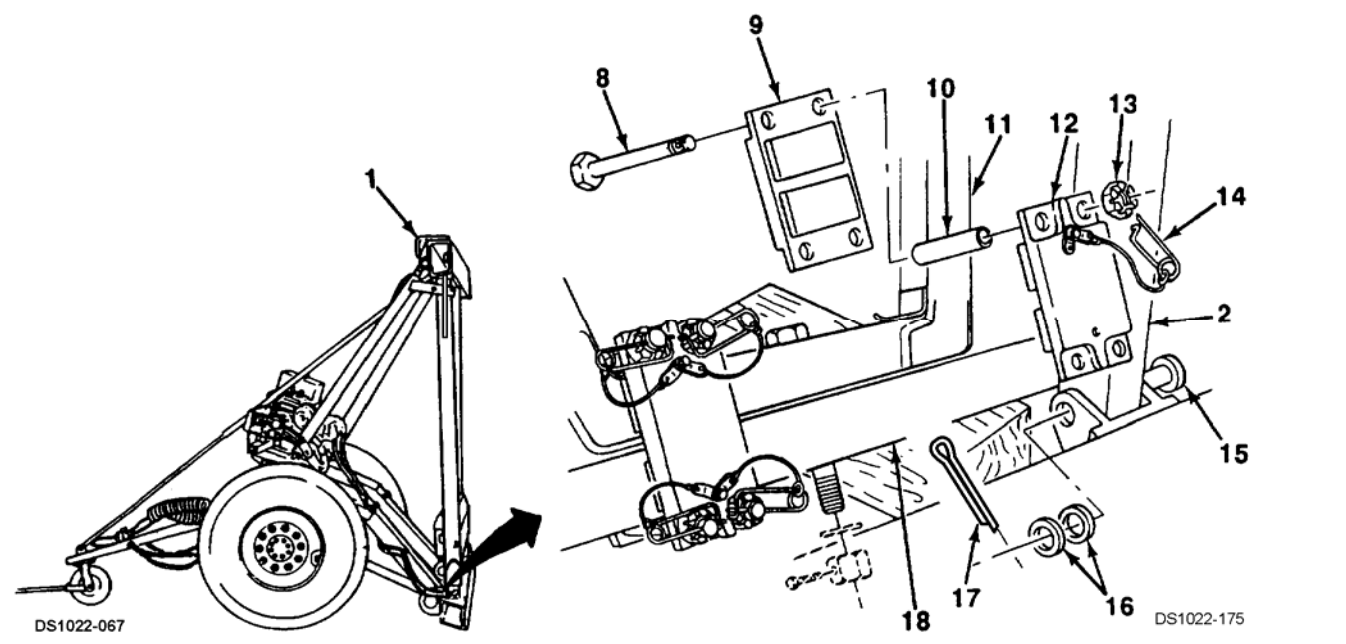
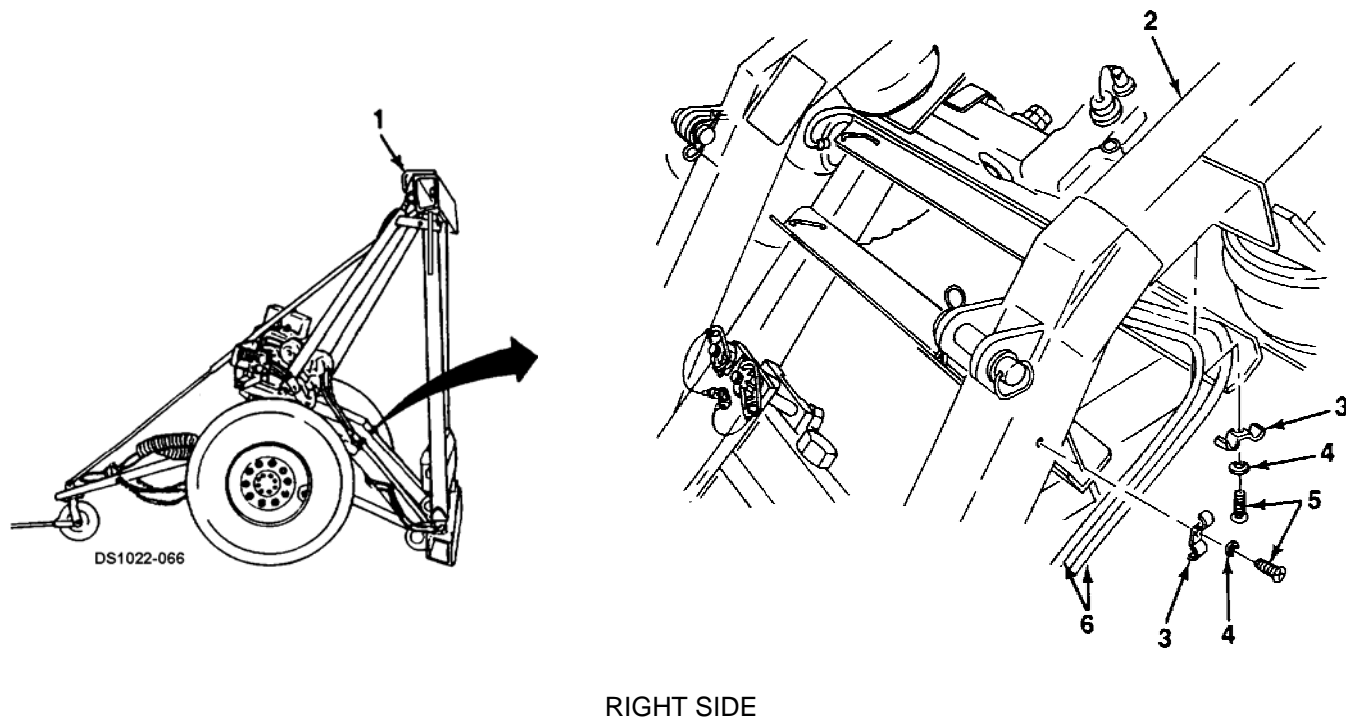
**NOTE**

**Note quantity of flatwashers removed to aid in installation.**

4. Remove two cotter pins (17) and flatwashers (16) from clevis pins (15). Drive out- DO NOT remove - clevis pins approximately 3 in. (7.6 cm) only until clear of pivot axle bracket (18). Discard cotter pins.
5. Remove eight safety pins (14) from bolts (8).
6. Remove four nuts (13), bolts (8) bottom lockout bracket (9) four sleeves (10), and top lockout bracket (12) from each end of pivot axle bracket (18) and axle assembly (11).

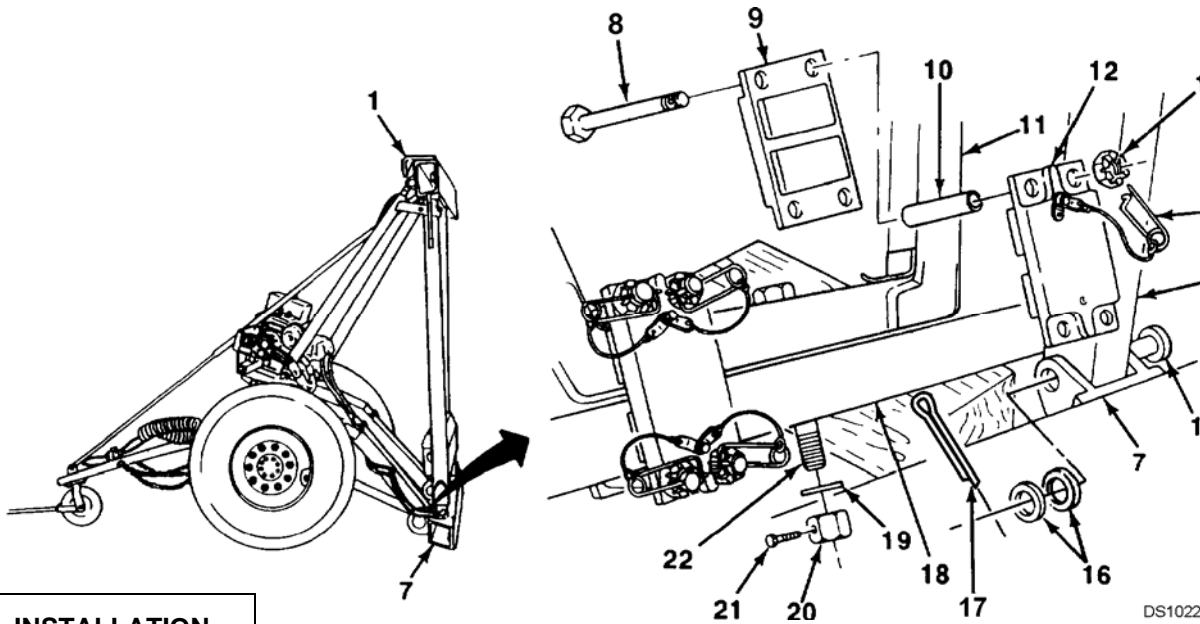


4-82. PIVOT AXLE BRACKET REPLACEMENT (Con't).



## 4-82. PIVOT AXLE BRACKET REPLACEMENT (Con't).

7. Remove setscrew (21) nut (20) washer (19) and pivot bolt (22) from axle assembly (11) and pivot axle bracket (18).
8. Raise top beam (1) 1-2 in. (2.5-5.0 cm) and remove pivot axle bracket (18) from bottom beam (7) and suspension links (2).
9. Lower top beam (1) and rest bottom beam (7) on ground.



### b. INSTALLATION

#### NOTE

**Perform steps 9 and 10 if only installing pivot axle bracket lockout brackets.**

1. Coat mating surface of pivot axle bracket (18) and axle assembly (11) with grease.
2. Inspect pivot bolt (22) to ensure that threads are not damaged. If damaged, dress threads.
3. Install pivot axle bracket (18) on axle assembly (11) with washer (19) and nut (20) loosely installed on pivot bolt (22).
4. Raise top beam (1) as required to align holes in pivot axle bracket (18), suspension links (2) and bottom beam (7).
5. Grease two clevis pins (15) and drive into suspension links (2).

#### NOTE

**An equal quantity of flatwashers must be installed on each side to reduce to a minimum the gap between suspension link and bottom beam pivot area.**

6. Install flatwashers (16) and new cotter pins (17) on clevis pins (15).

**4-82. PIVOT AXLE BRACKET REPLACEMENT (Con't).**

7. Lower top beam (1) and rest bottom beam (7) on ground. Remove lifting device from top beam.
8. Tighten nut (20) with wrench to seat pivot bolt (22). Loosen nut, then hand-tighten. Wrench tighten nut 1 to 1 1/4 flats. Install setscrew (21) in nut.

**NOTE**

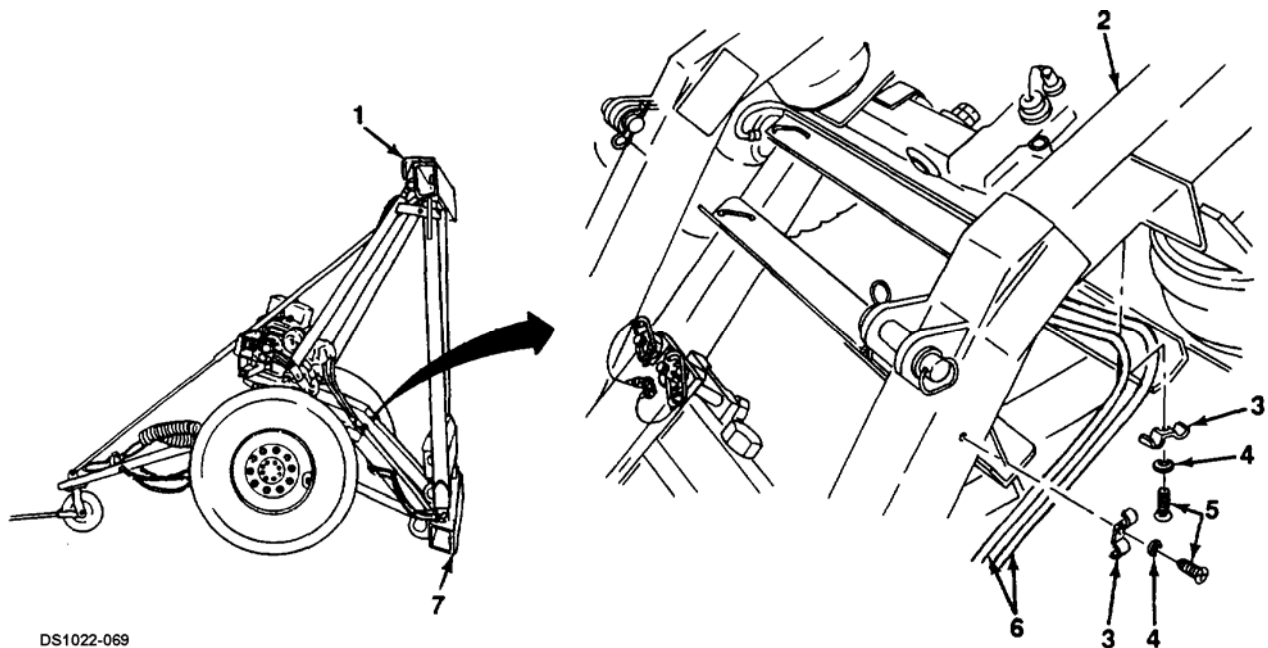
**Welded pads on axle and pivot axle bracket identify correct installation location of lockout bracket assemblies.**

9. Coat four bolts (8) with grease. Install top lockout bracket (12), four sleeves (10), bottom lockout bracket (9) four bolts, and nuts (13) on each end of pivot axle bracket (18) and axle assembly (11). Hand-tighten nuts, then tighten with wrench 1 1/4 to 2 flats.
10. Install eight safety pins (14) on bolts (8).

**NOTE**

**On right side, hose assemblies are secured to both side and underside of suspension link.**

11. Install two hydraulic hose assemblies (6) on each suspension link (2) with hose clamp (3) flat washer (4) and self-tapping screw (5).



DS1022-069

**RIGHT SIDE**

---

## 4-83. TOP AND BOTTOM BEAMS AND POSITIONING CYLINDERS REPLACEMENT.

---

This Task Covers:

- a. Removal
- b. Cleaning and Inspection
- c. Installation

---

*Initial Setup:*

### Equipment Conditions:

- Dolly set lowered, front and rear dollies detached (see paragraph 2-8).
- Ends of bottom beam supported on wooden blocks.
- Wheels chocked.
- Engine starter switch set to OFF position (see paragraph 2-20).
- Toolbox removed (front dolly) (see paragraph 4-103).

### Materials/Parts:

- Hydraulic fluid (Item 15, Appendix F)
- Grease (Item 19, Appendix F)
- Rags (Item 25, Appendix F)
- Dry cleaning solvent (Item 27, Appendix F)
- Marker tags (Item 28, Appendix F)
- Masking tape, 2 in. (Item 32, Appendix F)
- Four preformed packings
- Eight cotter pins
- Two self-locking nuts

### Tools/Test Equipment:

- General mechanic's tool kit (item 30, Appendix G)
- Suitable lifting device

**Personnel Required:** Three

### General Safety Instructions:

- Dry cleaning solvent is flammable and must not be used near an open flame. Use only in a well ventilated area.

---

**WARNING**

Use extreme caution when handling heavy parts. Lifting device is required when parts weigh over 50 lb (23 kg) for a single person lift, over 100 lb (45 kg) for a two person lift, and over 150 lb (68 kg) for a three or more person lift. Keep clear of heavy parts supported only by lifting device. Failure to follow this warning may cause serious injury or death to personnel.

### NOTE

- Replacement procedures are the same for front and rear dollies. Rear dolly replacement is illustrated.
- Positioning cylinders for M1022A1 and M1022A1 with side lift kit are replaced the same way.
- Hydraulic lines should be tagged before removal. Refer to paragraph 4-18 for tagging instructions.
- Positioning cylinder ports should be plugged with masking tape or other suitable means as lines are disconnected or fittings are removed. Refer to paragraph 4-22 for instructions.
- A suitable container should be used to catch any draining hydraulic fluid. Ensure that all spills are properly cleaned.

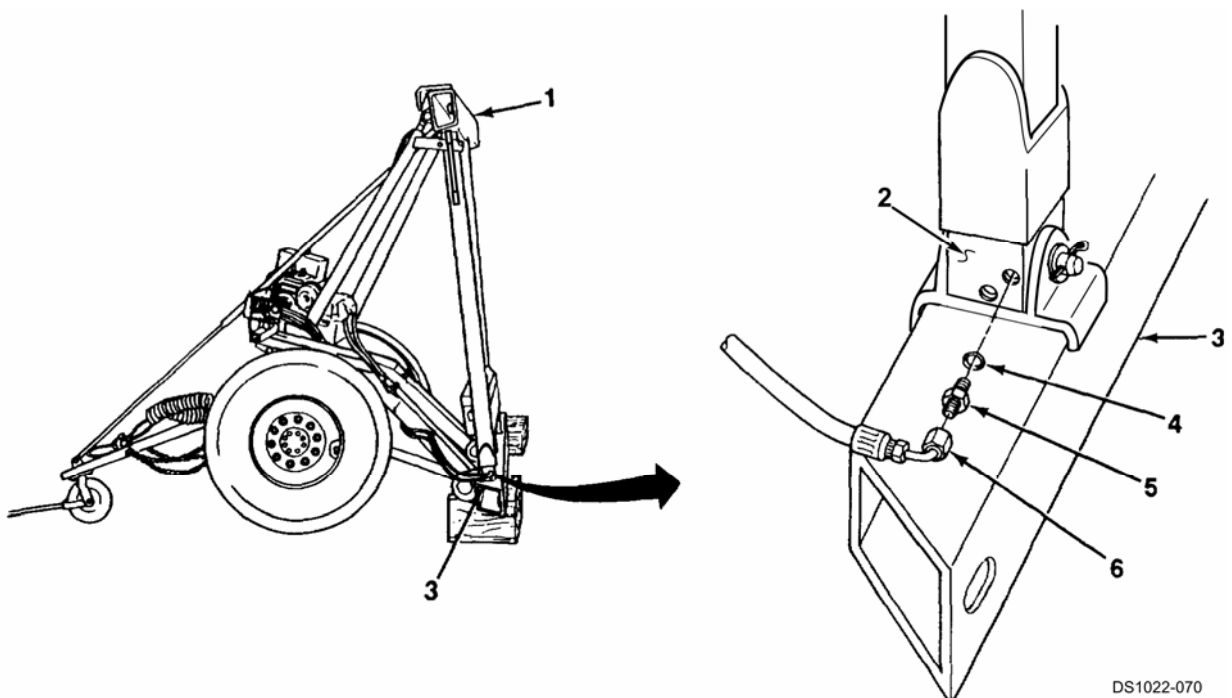
---

**4-83. TOP AND BOTTOM BEAMS AND POSITIONING CYLINDERS REPLACEMENT (Con't).**


---

**a. REMOVAL**
**WARNING**

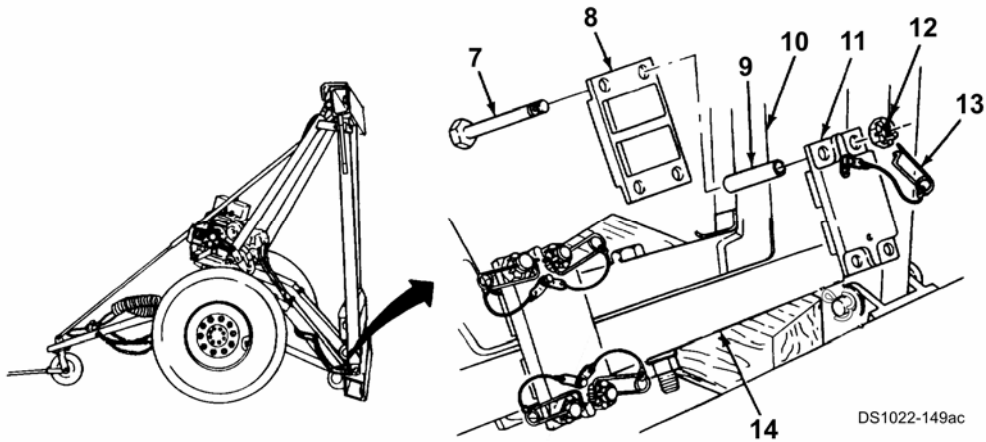
- **DO NOT** disconnect hydraulic lines and fittings while engine is running or before hydraulic system pressure has been released. When engine is running, hydraulic system is under pressure. Dolly set must be fully lowered to the ground and engine must be shut down before lines and fittings are disconnected. A line or fitting disconnected under pressure will explode with great force and cause serious injury or death to personnel.
  - Escaping hydraulic fluid under pressure can penetrate the skin, causing serious injury to personnel. Relieve pressure before disconnecting hydraulic lines and fittings. Tighten all connections before applying pressure. Keep hands and body away from pinholes and nozzles which eject hydraulic fluid under high pressure. Use a piece of cardboard or paper to search for leaks. If any hydraulic fluid is injected into the skin, it **MUST** be surgically removed within a few hours by a doctor familiar with this type of injury or gangrene may result.
1. Disconnect two hose assemblies (6) from straight connectors (5) at positioning cylinders (2) on bottom beam (3).
  2. Remove two straight connectors (5) and preformed packings (4) from positioning cylinders (2). Discard preformed packings.
  3. Attach a suitable lifting device to top beam (1) and adjust so that weight of top beam is on lifting device.



DS1022-070

**4-83. TOP AND BOTTOM BEAMS AND POSITIONING CYLINDERS REPLACEMENT (Con't).**

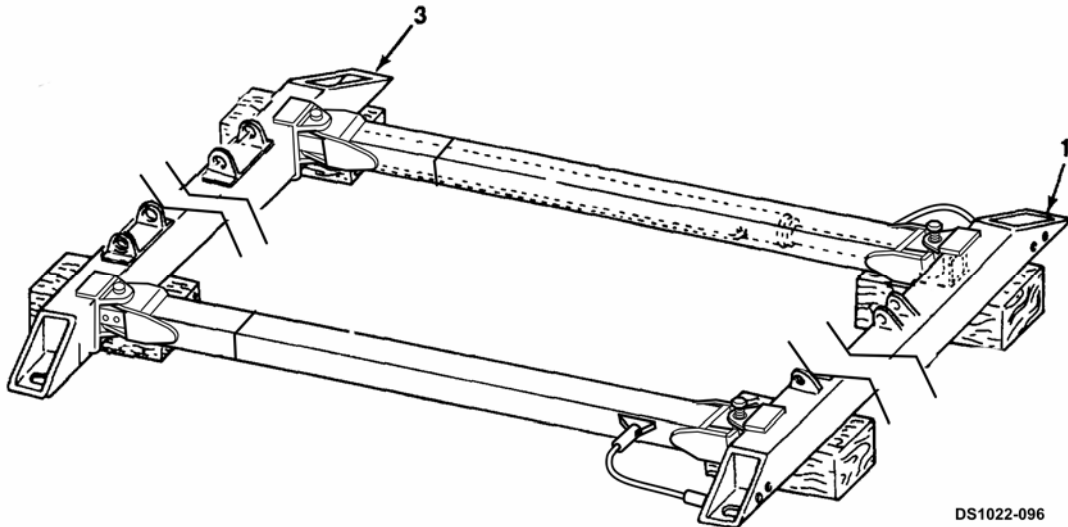
4. Remove telescopic brace (see paragraph 4-86).
5. Remove hydraulic lift cylinders from top beam (1) (see paragraph 4-110).
6. Optional: Lockout brackets (8 and 11) may interfere with bottom support beam when lowered. If needed, lockout brackets may be removed. To do so, remove eight safety pins (13) from bolts (7). Remove four nuts (12), bolts (7), bottom lockout bracket (8), four sleeves (9), and top lockout bracket (11) from each end of pivot axle bracket (14) and axle assembly (10).



**WARNING**

Use extreme caution when lowering top and bottom beams and placing on the ground. Ensure that lifting device is secure and all personnel stand clear. Failure to follow this warning may cause serious injury to personnel or damage to beams and positioning cylinders.

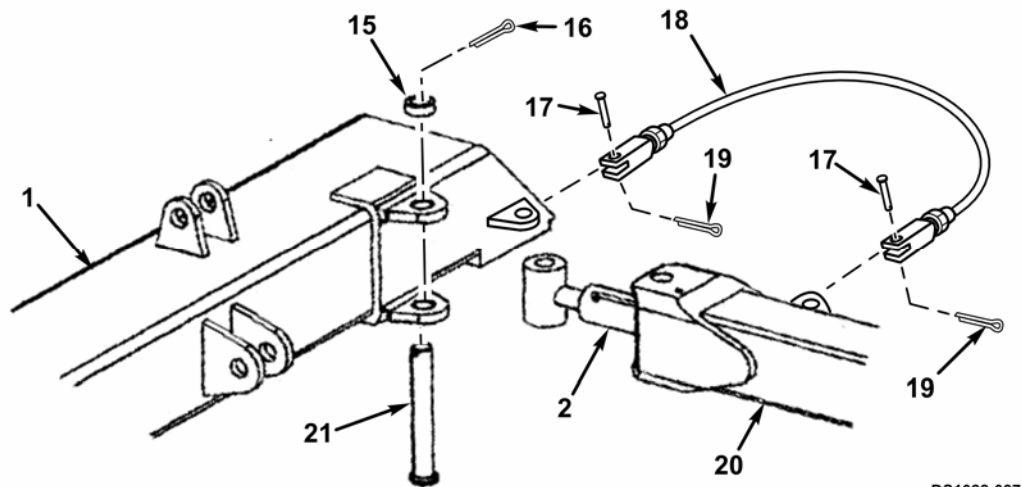
7. Lower top and bottom beams (1 and 3) to the ground and support on wooden blocks or other cribbing.



DS1022-096

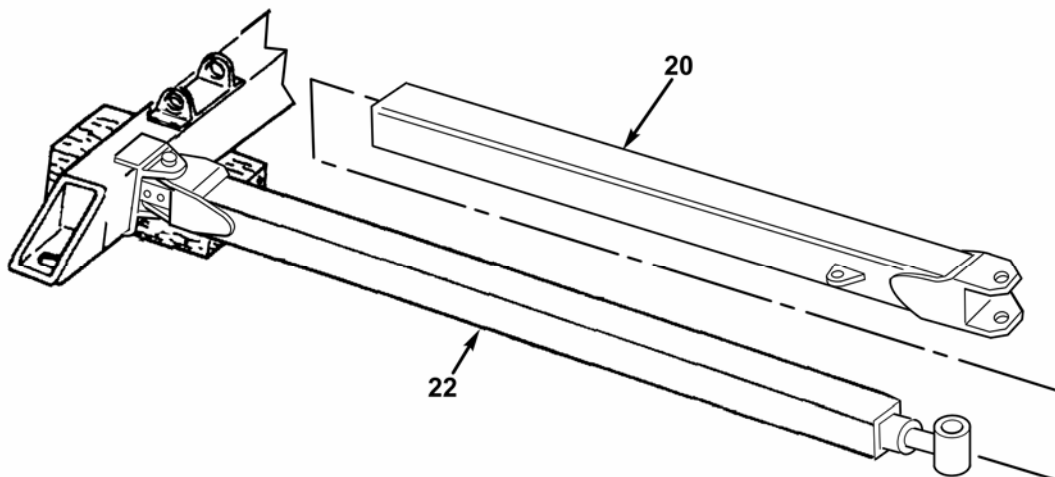
**4-83. TOP AND BOTTOM BEAMS AND POSITIONING CYLINDERS REPLACEMENT (Con't).**

8. Remove two cotter pins (19), clevis pins (17), and stability cable (18) from top beam (1) and upper vertical tube (20). Discard cotter pins
9. Remove cotter pin (16), spacer (15), and clevis pin (21) from top beam (1), upper vertical tube (20) and positioning cylinder (2). Discard cotter pin.
10. Repeat steps 8 and 9 to complete second upper vertical tube removal.
11. With top beam (1) and two upper vertical tubes (20) suitably supported, remove top beam (1) from two upper vertical tubes (20) and positioning cylinders (2).



DS1022-087

12. Remove two upper vertical tubes (20) from lower vertical tubes (22).



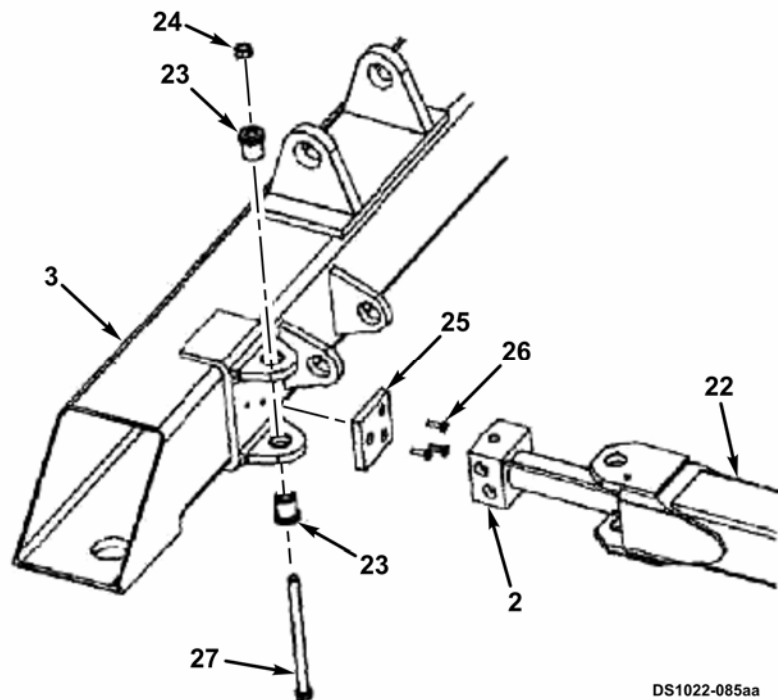
DS1022-088

---

**4-83. TOP AND BOTTOM BEAMS AND POSITIONING CYLINDERS REPLACEMENT (Con't).**

---

13. Remove self-locking nut (24), bolt (27), lower vertical tube (22) and positioning cylinder (2) from bottom beam (3). Discard self-locking nut.
14. Remove lower vertical tube (22) from positioning cylinder(2).
15. Remove two bushings (23) from bottom beam (3).
16. Remove three flathead bolts (26) and cylinder shim (25) from bottom beam (3).
17. Repeat steps 13 through 16 to complete second lower vertical tube removal.





---

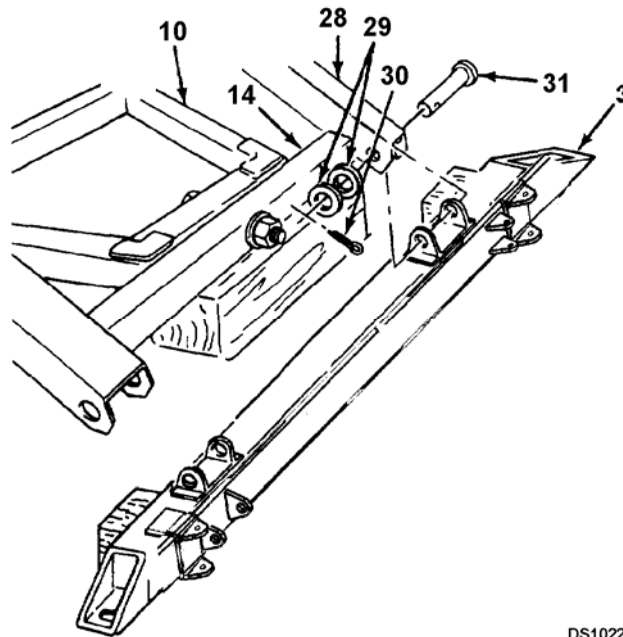
**4-83. TOP AND BOTTOM BEAMS AND POSITIONING CYLINDERS REPLACEMENT (Con't).**


---

**NOTE**

**Note quantity of flat washers removed to aid in installation.**

18. Place a wooden block or other suitable support under axle assembly (10) and pivot axle bracket (14). Remove two cotter pins (30), flat washers (29), and clevis pins (31) from suspension links (28) pivot axle bracket (14), and bottom beam (3). Discard cotter pins.
19. Separate bottom beam (3) from suspension links (28) and pivot axle bracket (14).



DS1022-089aa

**NOTE**

**Perform steps 20 through 24 if replacing top or bottom beam or if components are damaged.**

20. Remove top hooks (see paragraph 4-84).
21. Remove hanger brackets (front dolly) (see paragraph 4-100).
22. Remove detent pin lanyard assemblies (see paragraph 4-99).
23. Remove data plates (front dolly) (see paragraph 4-105).
24. Remove toolbox mounting brackets (front dolly) (see paragraph 4-97).



---

**4-83. TOP AND BOTTOM BEAMS AND POSITIONING CYLINDERS REPLACEMENT (Con't).**

---

[Text Deleted]

**b. CLEANING AND INSPECTION**

Drycleaning solvent, D-680, is toxic and flammable. Always wear protective goggles and gloves, and use only in a well-ventilated area. Avoid contact with skin, eyes, and clothes, and **DO NOT** breathe vapors. **DO NOT** use near open flame or excessive heat. The solvent's flash point is 100°F - 138°F (38° C-59° C). If you become dizzy while using cleaning solvent, immediately get fresh air and medical help. If solvent contacts eyes, immediately wash your eyes and seek medical attention.

1. Clean top and bottom beam mounting hardware and straight connectors with dry cleaning solvent and dry with clean rags.
2. Clean top and bottom beams as required to remove any grease, dirt, or mud.
3. Inspect all components for cracks, breaks, bends, corrosion or damaged threads. Replace damaged components.
4. Ensure that positioning cylinders limit lines are stenciled on bottom beam vertical tubes, 49 in. (124 cm) from bottom beam (see paragraph 1-14).

---

**4-83. TOP AND BOTTOM BEAMS AND POSITIONING CYLINDERS REPLACEMENT (Con't).**

---

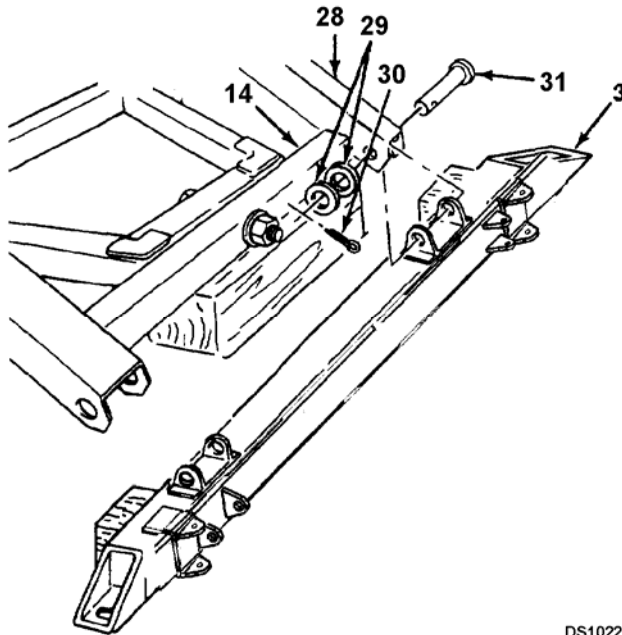
**c. INSTALLATION**

1. If removed, install toolbox mounting brackets (front dolly) (see paragraph 4-97).
2. If removed, install data plates (front dolly) (see paragraph 4-105).
3. If removed, install detent pin lanyard assemblies (see paragraph 4-99).
4. If removed, install hanger brackets (front dolly) (see paragraph 4-100).
5. If removed, install top hooks (see paragraph 4-84).
6. Position bottom beam (3) at pivot axle bracket (14) and two suspension links (28).

**NOTE**

**An equal quantity of flat washers must be installed on each side to reduce to a minimum the gap between suspension link and bottom beam pivot area.**

7. Grease two clevis pins (31). Install two clevis pins (31), flat washers (29), and new cotter pins (30) on bottom beam (3), pivot axle bracket (14), and two suspension links (28).



DS1022-089ab

---

**4-83. TOP AND BOTTOM BEAMS AND POSITIONING CYLINDERS REPLACEMENT (Con't).**


---

8. Install cylinder shim (25) on bottom beam(3) with three flat head bolts (26). Torque bolts to 10 lb-ft (14 N•m).
9. With bottom beam (3) and lower vertical tube (22) fully supported, position mounting tabs on lower vertical tube (22) between tube mount tabs on bottom beam (3).

**NOTE**

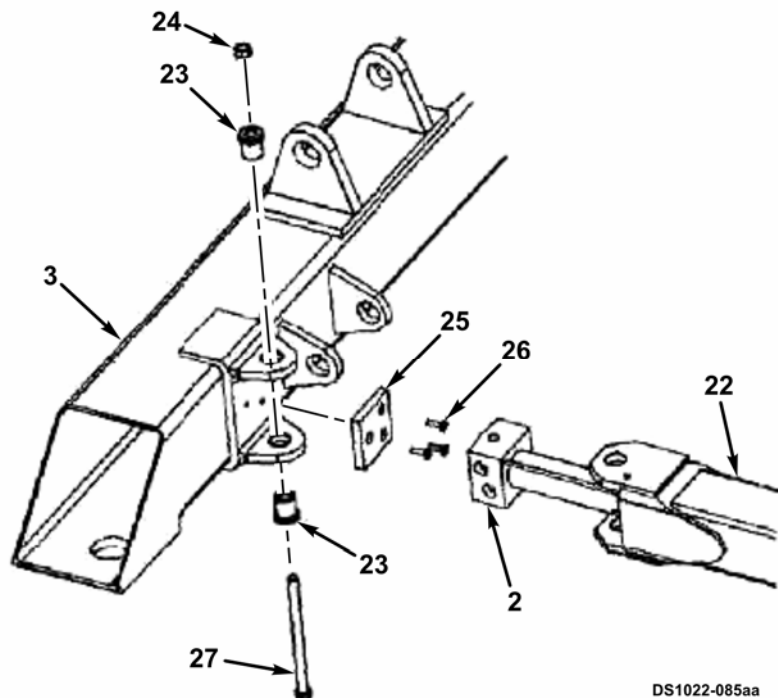
- Ensure that opening for hydraulic fittings in positioning cylinders are facing outboard.
- To ensure proper assembly, install items (23), (24), and (25) as illustrated.

10. Insert positioning cylinder (2) into lower vertical tube (22) with hydraulic connections facing outboard.

**NOTE**

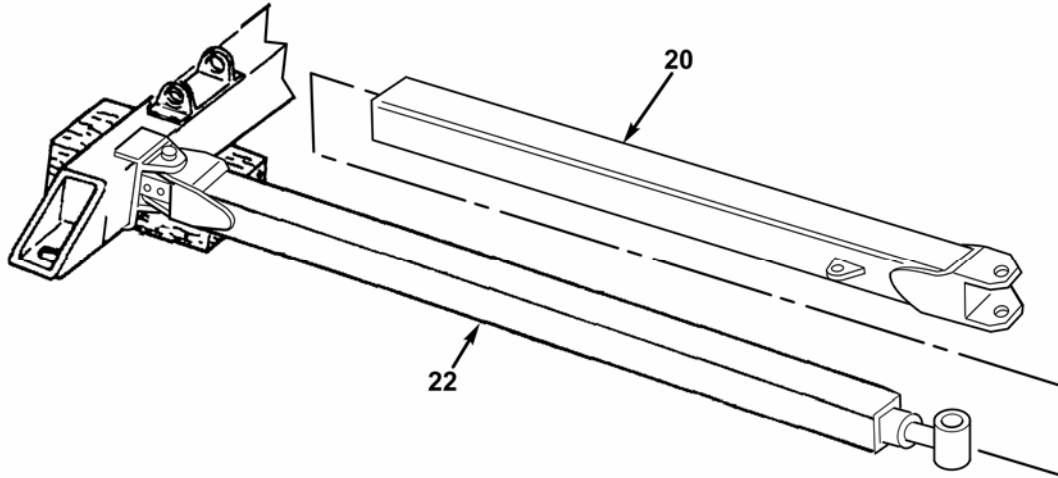
**Ensure that bushings are installed with shoulder on outside of tube mount tabs on bottom beam and are fully seated in tabs.**

11. Install positioning cylinder (2) and lower vertical tube (22) on bottom beam (3) with bolt (27), two bushings (23), and new self-locking nut (24). Torque self-locking nut between 25-30 lb-ft (34-41 N•m).
12. Repeat steps 8 through 11 to complete second lower vertical tube installation.



4-83. TOP AND BOTTOM BEAMS AND POSITIONING CYLINDERS REPLACEMENT (Con't).

13. Install upper vertical tube (20) over assembled lower vertical tube (22) with stability cable mount positioned outboard.

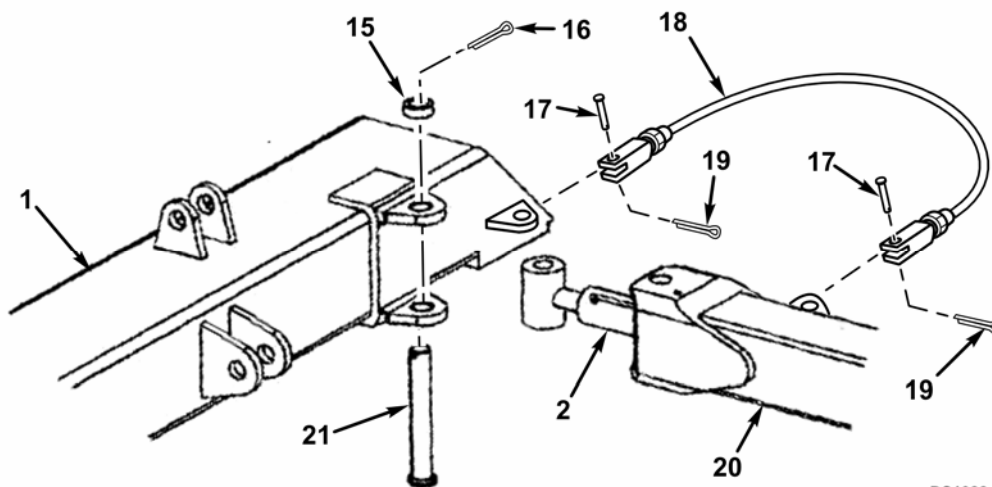


DS1022-088

**NOTE**

- Ensure that hole at rod end of positioning cylinder is aligned with holes in mounting tabs on top beam.
- To ensure proper assembly install items (15), (16), and (21), as illustrated.

14. With top beam (1) and upper vertical tube (20) fully supported, install positioning cylinder (2) and upper vertical tube (20) on top beam (1) with clevis pin (21), spacer (15), and new cotter pin (16).
15. Install stability cable (18) on top beam (1) and upper vertical tube (20) with two clevis pins (17) and new cotter pins (19).
16. Repeat Steps 13 through 15 to complete second upper vertical tube installation.



DS1022-087

---

**4-83. TOP AND BOTTOM BEAMS AND POSITIONING CYLINDERS REPLACEMENT (Con't).**

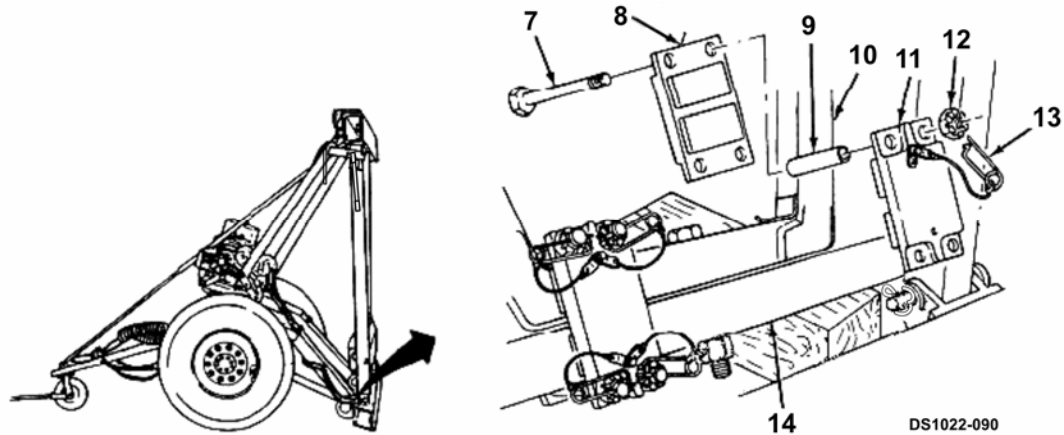

---

[Text Deleted]

<b>WARNING</b>
----------------

**Use extreme caution when raising top and bottom beams. Ensure that lifting device is secure and all personnel stand clear. Failure to follow warning may cause serious injury to personnel or damage to beams and positioning cylinders.**

17. Raise the assembled top and bottom beams with positioning cylinders (2) installed to a vertical position.
18. If lockout brackets were removed, reinstall at this time. To do so, coat four bolts (7) with grease. Install top lockout bracket (11), four sleeves (9), bottom lockout bracket (8), four bolts (7) and nuts (12) on each end of pivot axle assembly (14) and axle assembly (10). Hand tighten nuts, then tighten with wrench 1 ¼ to 2 flats. Install eight safety pins (13) on bolts (7).



19. Install hydraulic lift cylinders (see paragraph 4-110).
20. Remove lifting device from top beam (1).
21. Install telescopic brace (see paragraph 4-86).

---

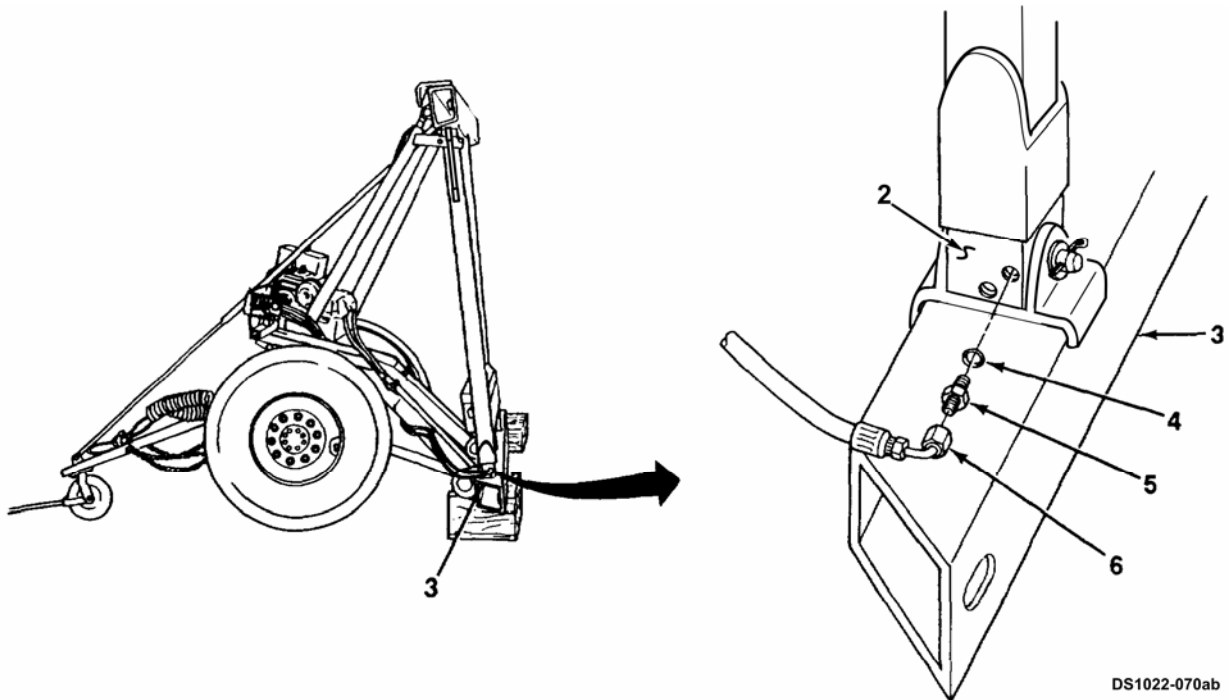
**4-83. TOP AND BOTTOM BEAMS AND POSITIONING CYLINDERS REPLACEMENT (Con't).**

---

**NOTE**

**Preformed packings should be lightly coated with hydraulic fluid before installation.**

22. Install two new preformed packings (4) and straight connectors (5) on positioning cylinders (2) on bottom beam (3).
23. Connect two hose assemblies (6) to straight connectors (5) at positioning cylinders (2).



DS1022-070ab

**Follow-on Tasks:**

- Install toolbox (front dolly) (see paragraph 4-103).
- Bleed hydraulic system (see paragraph 4-112).
- Check for leaks.
- Remove wooden blocks from ends of bottom beam.



---

#### 4-84. TOP HOOK REPLACEMENT.

---

*This Task Covers:*

a. Removal

b. Installation

*Initial Setup:*

**Materials/Parts:**

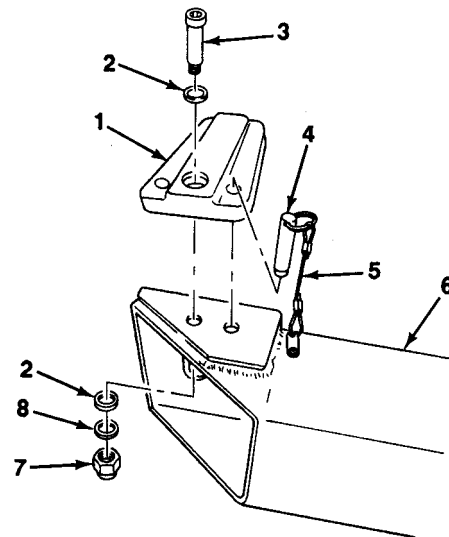
- One locknut

**Tools/Test Equipment:**

- General mechanic's tool kit (Item 30, Appendix G)
- 

#### a. REMOVAL

1. Remove detent pin (4) from top hook (1) and top beam (6).
2. Remove locknut (7), flatwasher (8), flatwasher (2), shoulder screw (3), flatwasher (2), and top hook (1) from top beam (6). Discard locknut.
3. If detent pin (4) is damaged, remove with lanyard assembly (5) (see paragraph 4-99).



#### b. INSTALLATION

1. If removed, install detent pin (4) and lanyard assembly (5) (see paragraph 4-99).
2. Install top hook (1) on top beam (6) with flatwasher (2), shoulder screw (3), flatwasher (2), flatwasher (8), and new locknut (7). Wrench tighten locknut until snug, while still allowing manual rotation of top hook.
3. Install detent pin (4) on top hook (1) and top beam (6).

---

## 4-85. TRANSPORTATION LOCKOUT REPLACEMENT.

---

*This Task Covers:*

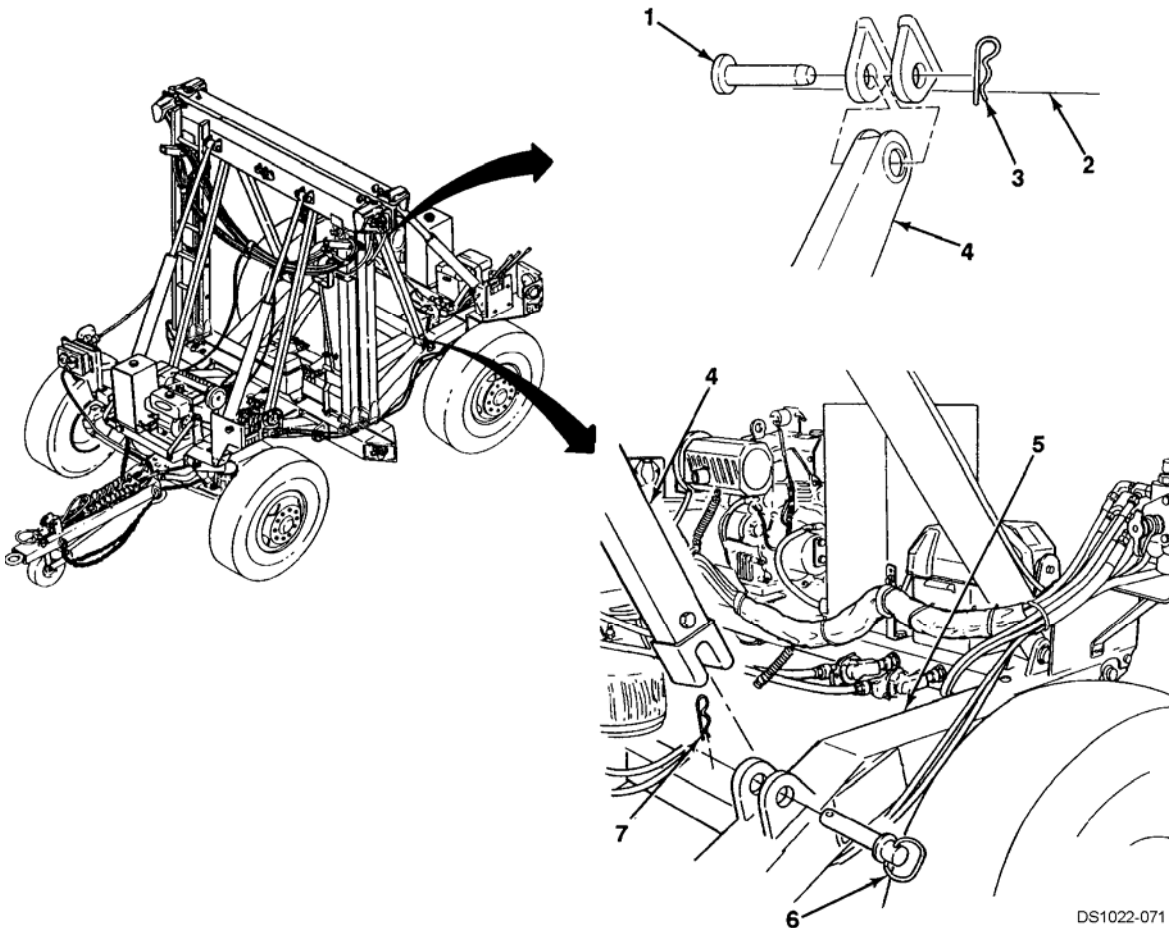
a. Removal

b. Installation

---

### a. REMOVAL

1. If engaged, operate hydraulic control valve to extend lift cylinder (see paragraph 2-21). Disengage transportation lockout (4) from hitch pin (6) at suspension link (5).
2. Remove lockpin (3), clevis pin (1), and transportation lockout (4) from top beam (2).
3. If damaged, remove lockpin (7) and hitch pin (6) from suspension link (5).



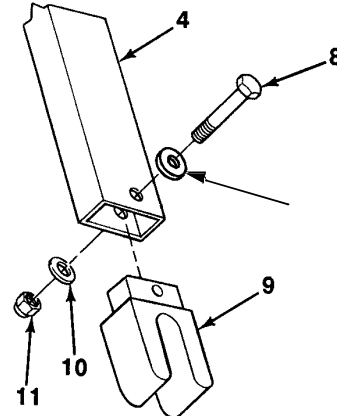
DS1022-071

---

## 4-85. TRANSPORTATION LOCKOUT REPLACEMENT (Cont).

---

4. If damaged, remove self-locking nut (11), flat washer (10), capscrew (8), flatwasher (8.1), and end fitting (9) from transportation lockout (4). Discard self-locking nut.



### **b. INSTALLATION**

1. If removed, install end fitting (9) to transportation lockout (4) with flatwasher (8.1), capscrew (8), flat washer (10), and new self-locking nut (11).
2. If removed, install hitch pin (6) and lockpin (7) to suspension link (5).
3. Install transportation lockout (4) on top beam (2) with clevis pin (1) and lockpin (3).
4. Operate hydraulic control valve as required to engage transportation lockout (4) on hitch pin (6) at suspension link (5) (see paragraph 2-21).

---

## 4-85. TRANSPORTATION LOCKOUT REPLACEMENT (Cont).

---

*This Task Covers:*

- a. Removal b. Installation
- 

### NOTE

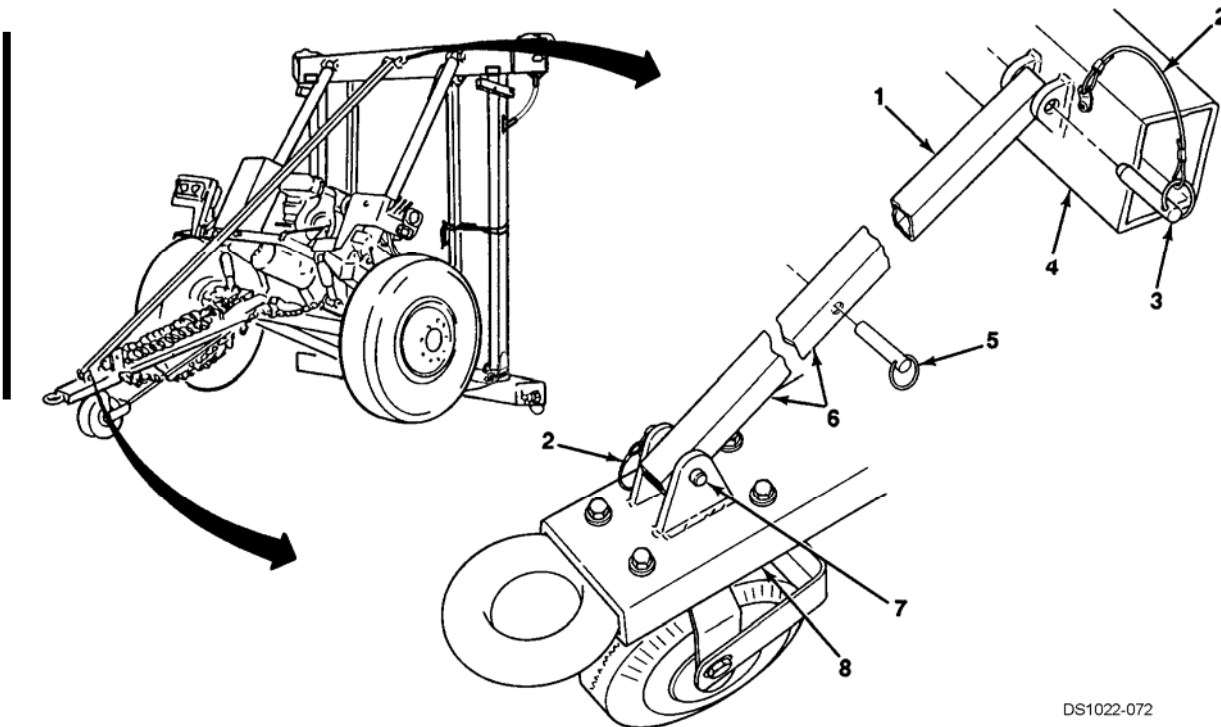
Front and rear dolly telescopic braces are replaced the same way except as noted. Front dolly telescopic brace is illustrated.

<b>a. REMOVAL</b>
-------------------

### NOTE

On rear dolly, telescopic brace is removed from telescopic brace bracket bolted to rear drawbar.

1. Remove detent pin (7) and brace (6) from front drawbar (8).
2. Remove detent pin (3) and brace (1) from top beam (4).
3. Remove detent pin (5) from brace (6).



DS1022-072

---

**4-86. TELESCOPIC BRACE REPLACEMENT (Con't).**

---

4. Remove brace (6) from brace (1).
5. If detent pins (3 and 7) are damaged, remove with lanyard assemblies (2) (see paragraph 4-99).

**b. INSTALLATION**

1. If removed, install detent pins (3 and 7) and lanyard assemblies (2) (see paragraph 4-99).
2. Install brace (6) inside brace (1).
3. Install detent pin (5) in fourth hole from end of brace (6).
4. Install brace (1) on top beam (4) with detent pin (3).

## NOTE

On rear dolly, telescopic brace is installed on telescopic brace bracket bolted to rear drawbar.

5. Install brace (6) on front drawbar (8) with detent pin (7).

---

## 4-87. FRONT DRAWBAR DUMMY COUPLING REPLACEMENT.

---

This Task Covers:

- a. Removal b. Installation
- 

Initial Setup:

Equipment Conditions:

- Intervehicular gladhand removed from dummy coupling (see paragraph 2-11).

Materials/Parts:

- Two locknuts

Tools/Teat Equipment:

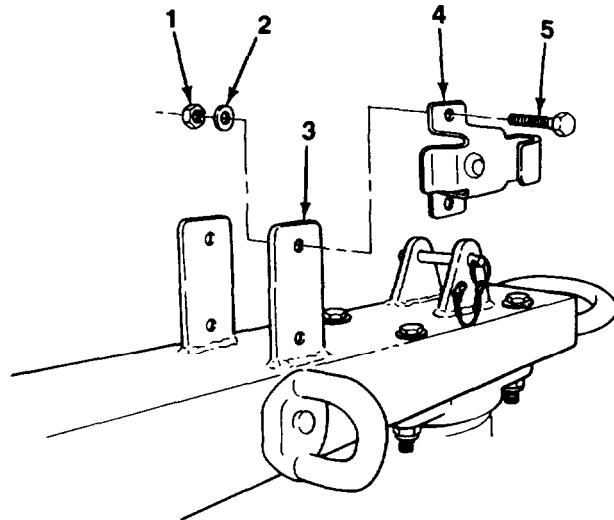
- General mechanic's tool kit (item 30, Appendix G)
- 

### a. REMOVAL

Remove two locknuts (1), flatwashers (2), bolts (5), and dummy coupling (4) from front drawbar (3). Discard locknuts.

### b. INSTALLATION

Install dummy coupling (4) on front drawbar (3) with two bolts (5), flatwashers (2) and new locknuts (1).



Follow-on Tasks:

- Install intervehicular gladhand in dummy coupling (see paragraph 2-7).

---

## 4-88. REAR DRAWBAR REPLACEMENT.

---

This Task Covers:

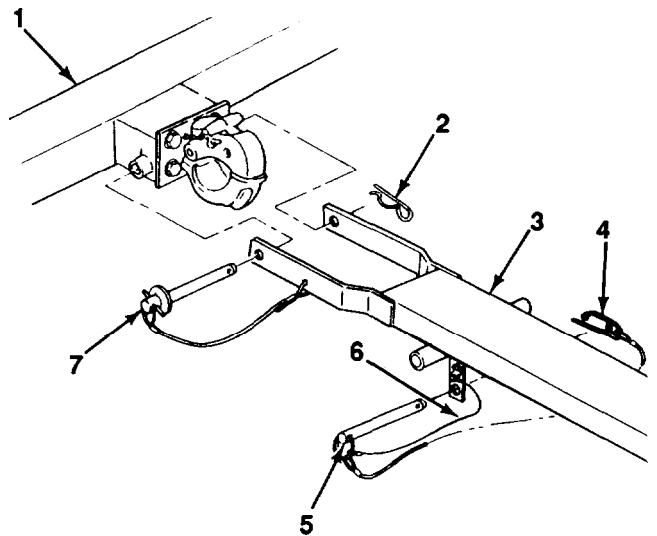
a. Removal

1. Remove safety pin (2), pin (7), and rear drawbar (3) from rear axle assembly (1).
2. Install safety pin (2) on pin (7).
3. If safety pin (4) and hitch pin (5) for handle stowage are damaged, remove with lanyard assembly (6) (see paragraph 4-99).

NOTE

Perform steps 4 through 6 if replacing rear drawbar.

4. Remove pin (7) assembly (see paragraph 4-89).
5. Remove data plate (see paragraph 4-105).
6. Remove caster wheel assembly and telescopic brace bracket (see paragraph 4-91).



b. Installation

**b. INSTALLATION**

1. If removed, install caster wheel assembly and telescopic brace bracket (see paragraph 4-91).
2. If removed, install data plate (see paragraph 4-105).
3. If removed, install pin (7) assembly on rear drawbar (3) (see paragraph 4-89).
4. If removed, install hitch pin (5) and safety pin (4) with lanyard assembly (6) on rear drawbar (3) (see paragraph 4-99).
5. Remove safety pin (2) from pin (7).
6. Install rear drawbar (3) on rear axle assembly (1) with pin (7) and safety pin (2).

---

## 4-89. REAR DRAWBAR PIN ASSEMBLY REPLACEMENT.

---

This Task Covers:

- |                |                 |
|----------------|-----------------|
| a. Removal     | c. Assembly     |
| b. Disassembly | d. Installation |
- 

Initial/ Setup:

Equipment Conditions:

- Rear drawbar removed (see paragraph 4-88).

Materials/Parts:

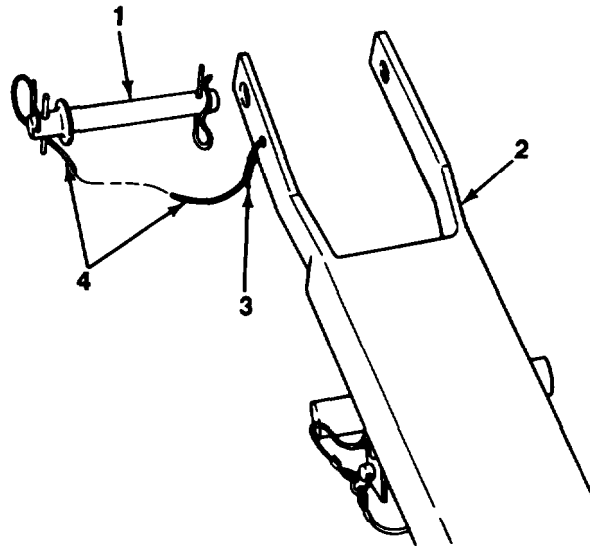
- Two sleeves

Tools/Test Equipment:

- General mechanic's tool kit (Item 30, Appendix G)
- 

### **a. REMOVAL**

1. Cut lanyard cable (4) and remove pin assembly (1) from rear drawbar (2).
2. Discard sleeve (3).



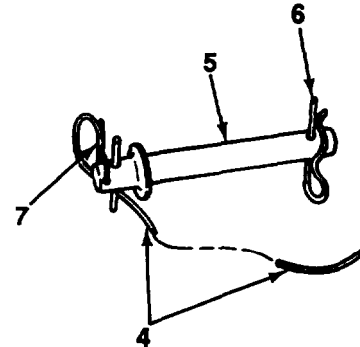


---

**4-89. REAR DRAWBAR PIN ASSEMBLY REPLACEMENT (Con't).**


---

1. Remove safety pin (6) from pin (5).
2. Cut lanyard cable (4) from pin (5). Discard lanyard cable and sleeve (7).


**c. ASSEMBLY**

1. Install lanyard cable (4) through hole in pin (5). Pull loop snug and install new sleeve (7). Crimp sleeve.
2. Install safety pin (6) through pin (5).

**d. INSTALLATION**

Feed lanyard cable (4) through hole in rear drawbar (2). Pull loop snug and install new sleeve (3). Crimp sleeve

Follow-on Tasks:

- Install rear drawbar (see paragraph 4-88).

---

## 4-90. PINTLE ASSEMBLY REPLACEMENT.

---

This Task Covers:

a. Removal

b. Installation

---

Initial Setup:

Materials/Parts:

· Four lockwashers

Tools/Test Equipment:

· General mechanic's tool kit (item 30, Appendix G)

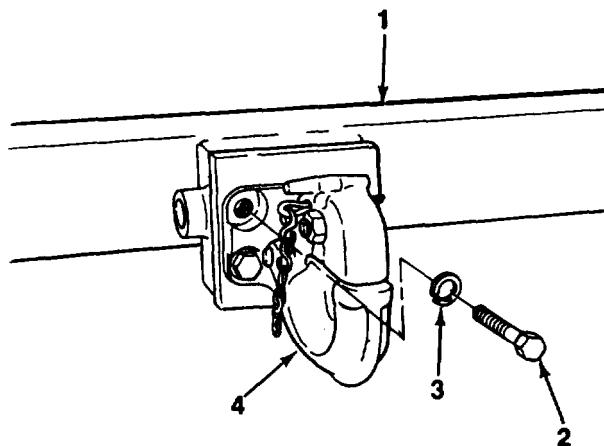
---

### **a. REMOVAL**

Remove four capscrews (2), lockwashers (3), and pintle assembly (4) from rear axle assembly (1). Discard lockwashers.

### **b. INSTALLATION**

Install pintle assembly (4) on rear axle assembly (1) with four new lockwashers (3) and capscrews (2).



---

**4-91. CASTER WHEEL ASSEMBLY MAINTENANCE.**

---

*This Task Covers:*

- |                |                 |
|----------------|-----------------|
| a. Removal     | c. Assembly     |
| b. Disassembly | d. Installation |

*Initial Setup:*

**Materials/Parts:**

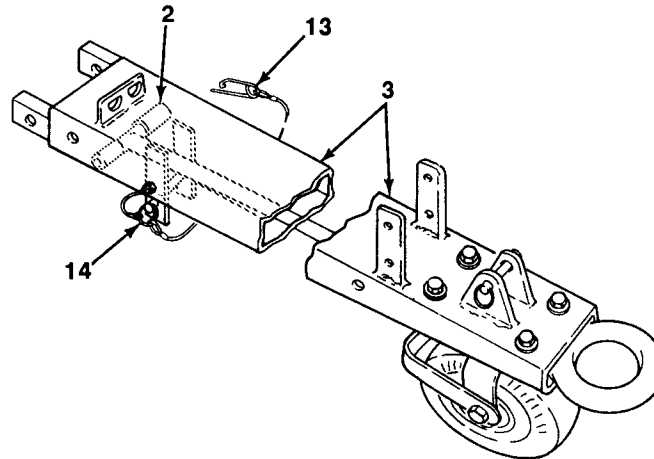
- Five locknuts

**Tools/Test Equipment:**

- General mechanic's tool kit (Item 30, Appendix G)
- Torque wrench, 0-200 lb.-in. (Item 41, Appendix G)

**a. REMOVAL**

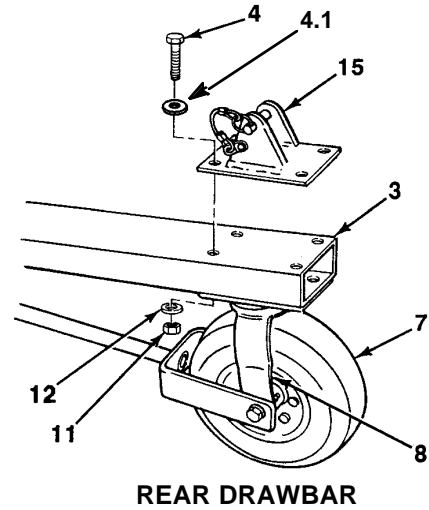
1. Remove safety pin (13) and hitch pitch pin (14) and release handle (2) from stowage under drawbar (3).



**FRONT DRAWBAR**

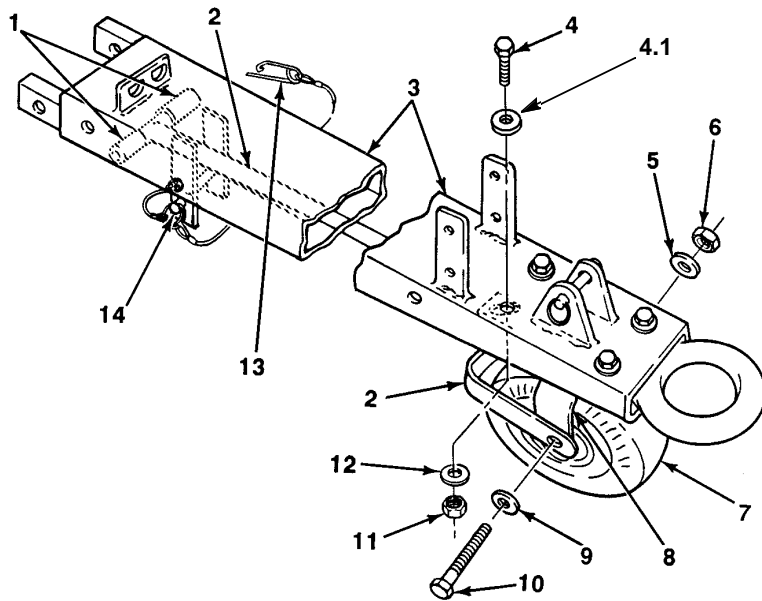
**4-91. CASTER WHEEL ASSEMBLY MAINTENANCE (Con't).**

2. Remove four locknuts (11), flatwashers (12), capscrews (4), flatwashers (4.1), telescopic brace bracket (15) (rear drawbar), and caster wheel (8) with tire (7) from drawbar (3). Discard locknuts.



**b. DISASSEMBLY**

1. Remove lockout (6), flatwasher (5), bolt (10), and flatwasher (9) from handle (2). Discard lockout.
2. Separate handle (2) from tire (7) and caster wheel (8).
3. Remove two vinyl grips (1) from handle (2).



---

**4-91. CASTER WHEEL ASSEMBLY MAINTENANCE (Con't).**

---

**c. ASSEMBLY**

1. Install two vinyl grips (1) on handle (2).
2. Install handle (2) on tire (7) and caster wheel (8) with flatwasher (9), bolt (10), flatwasher (5), and new lock-nut (6).

**d. INSTALLATION****CAUTION**

**Overtightening of caster wheel mounting hardware to rear drawbar will damage rear drawbar.**

1. Install caster wheel (8) with tire (7) and telescopic brace bracket (15) (rear drawbar) on drawbar (3) with four flatwashers (4.1), capscrews (4), flatwashers (12), and new locknuts (11). Torque locknuts on rear drawbar to 108-120 lb.-in. (12-14 N•m).
2. Stow handle (2) under drawbar (3) and secure with hitch pin (14) and safety pin (13).

**Follow-on Tasks:**

- Lubricate caster wheel assembly (see Lubrication Instructions, Chapter 3, Section I).

---

## 4-92. FRONT DOLLY JUNCTION BOX BRACKET REPLACEMENT.

---

*This Task Covers:*

a. Removal

b. Installation

---

*Initial Setup:*

**Equipment Conditions:**

- Signal conditioning box and forward junction box removed (see paragraph 4-33).
- Marker clearance light removed (see paragraph 4-38)
- Reflector removed (see paragraph 4-104).

**Materials/Parts:**

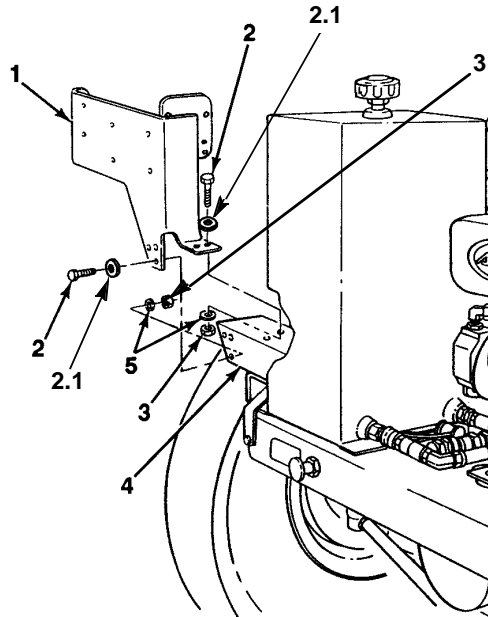
- Five locknuts

**Tools/Test Equipment:**

- General mechanic's tool kit (Item 30, Appendix G)
- 

**a. REMOVAL**

Remove five locknuts (3), flatwashers (5), capscrews (2), flatwashers (2.1), and bracket (1) from brace (4). Discard locknuts.



**b. INSTALLATION**

Install bracket (1) on brace (4) with five flatwashers (2.1), capscrews (2), flatwashers (5), and new locknuts (3).

**Follow-on Tasks:**

- Install reflector (see paragraph 4-104).
- Install marker clearance light (see paragraph 4-38).
- Install signal conditioning box and forward junction box (see paragraph 4-33).

## 4-93. FRONT DOLLY HYDRAULIC CONTROL VALVE BRACKET REPLACEMENT.

*This Task Covers:*

a. Removal

b. Installation

*Initial Setup:*

### Equipment Conditions:

- Hydraulic control valve removed (see paragraph 4-108).
- Marker clearance light removed (see paragraph 4-38).
- Reflector removed (see paragraph 4-104).

### Materials/Parts:

- Five locknuts

### Tools/Test Equipment:

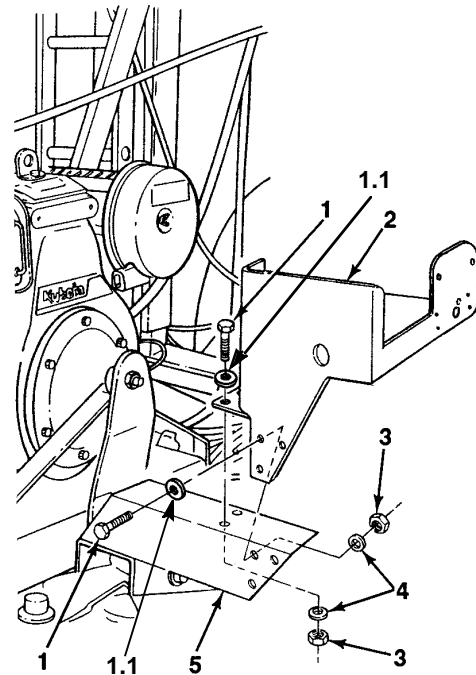
- General mechanic's tool kit (Item 30, Appendix G)

### a. REMOVAL

1. Remove five locknuts (3), flatwashers (4), capscrews (1), flatwashers (1.1), and bracket (2) from brace (5). Discard lockouts.
2. If damaged or if replacing bracket (2), remove data plates (see paragraph 4-105).

### b. INSTALLATION

1. If removed, install data plates (see paragraph 4-105).
2. Install bracket (2) on brace (5) with five flatwashers (1.1), capscrews (1), flatwashers (4), and new lockouts (3).



### Follow-on Tasks:

- Install reflector (see paragraph 4-104).
- Install marker clearance light (see paragraph 4-38).
- Install hydraulic control valve (see paragraph 4-108).

---

## 4-94. FRONT DOLLY BRACE REPLACEMENT.

---

*This Task Covers:*

- a. Removal b. Installation
- 

*Initial Setup:*

**Equipment Conditions:**

- Front dolly junction box bracket removed (right side) (see paragraph 4-92).
- Front dolly hydraulic control valve bracket removed (left side) (see paragraph 4-93).
- Shock absorber removed from suspension link (see paragraph 4-102).

**Materials/Parts:**

- Four locknuts

**Tools/Test Equipment:**

- General mechanic's tool kit (Item 30, Appendix G)
- 

**NOTE**

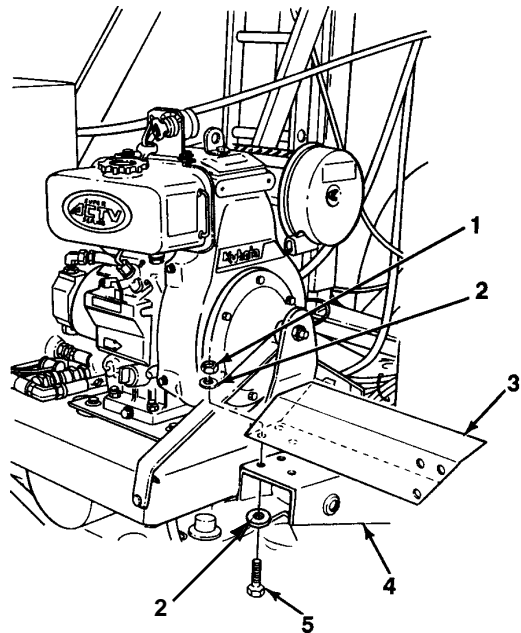
Left side and right side braces are replaced the same way. Right side brace is illustrated.

**a. REMOVAL**

Remove four locknuts (1), eight flatwashers (2), four capscrews (5), and brace (3) from suspension link (4). Discard locknuts.

**b. INSTALLATION**

Install brace (3) on suspension link (4) with four capscrews (5), eight flatwashers (2), and four new locknuts (1).



**Follow-on Tasks:**

- Install shock absorber on suspension link (see paragraph 4-102).
- Install front dolly hydraulic control valve bracket (left side) (see paragraph 4-93).
- Install front dolly junction box bracket (right side) (see paragraph 4-92).



## 4-95. REAR DOLLY JUNCTION BOX BRACKET REPLACEMENT.

*This Task Covers:*

- a. Removal b. Installation

*Initial Setup:*

### Equipment Conditions:

- Taillight assembly housing removed (see paragraph 4-41).
- Rear junction box removed (see paragraph 4-36).
- Shock absorber removed from suspension link (see paragraph 4-102).

### Materials/Parts:

- Three locknuts

### Tools/Test Equipment:

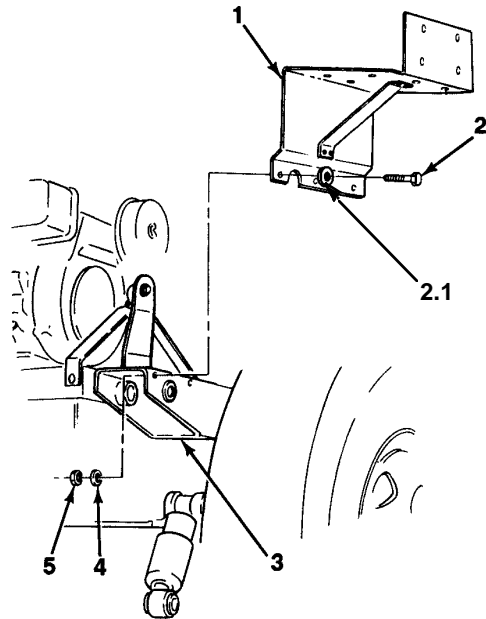
- General mechanic's tool kit (Item 30, Appendix G)

### a. REMOVAL

Remove three locknuts (5), flatwashers (4), capscrews (2), flatwashers (2.1), and bracket (1) from suspension link (3). Discard locknuts.

### b. INSTALLATION

Install bracket (1) on suspension link (3) with three flatwashers (2.1), capscrews (2), flatwashers (4), and new locknuts (5).



### Follow-on Tasks:

- Install shock absorber on suspension link (see paragraph 4-102).
- Install rear junction box (see paragraph 4-36).
- Install taillight assembly housing (see paragraph 4-41).

---

## 4-96. REAR DOLLY HYDRAULIC CONTROL VALVE BRACKET REPLACEMENT.

---

*This Task Covers:*

- a. Removal
- b. Installation

*Initial Setup:*

**Equipment Conditions:**

- Taillight assembly housing removed (see paragraph 4-41).
- Hydraulic control valve removed (see paragraph 4-108).
- Shock absorber removed from suspension link (see paragraph 4-102).

**Materials/Parts:**

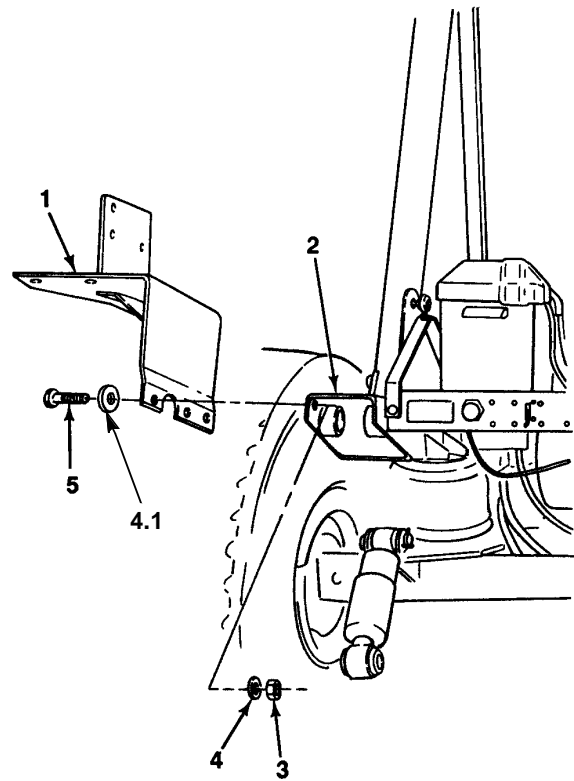
- Three locknuts

**Tools/Test Equipment:**

- General mechanic's tool kit (Item 30, Appendix G)

**a. REMOVAL**

1. Remove three locknuts (3), flatwashers (4), capscrows (5), flatwashers (4.1), and bracket (1) from suspension link (2). Discard locknuts.
2. If damaged or if replacing bracket (1), remove data plates (see paragraph 4-105).



**b. INSTALLATION**

1. If removed, install data plates (see paragraph 4-105).
2. Install bracket (1) on suspension link (2) with three flatwashers (4.1) capscrows (5), flatwashers (4), and new locknuts (3).

**Follow-on Tasks:**

- Install shock absorber on suspension link (see paragraph 4-102).
- Install hydraulic control valve (see paragraph 4-108).
- Install taillight assembly housing (see paragraph 4-41).

---

## 4-97. TOOLBOX MOUNTING BRACKETS REPLACEMENT.

---

*This Task Covers:*

- a. Removal b. Installation
- 

*Initial Setup:*

**Equipment Conditions:**

- Toolbox removed (see paragraph 4-103).

**Materials/Parts:**

- Four rivets

**Tools/Test Equipment:**

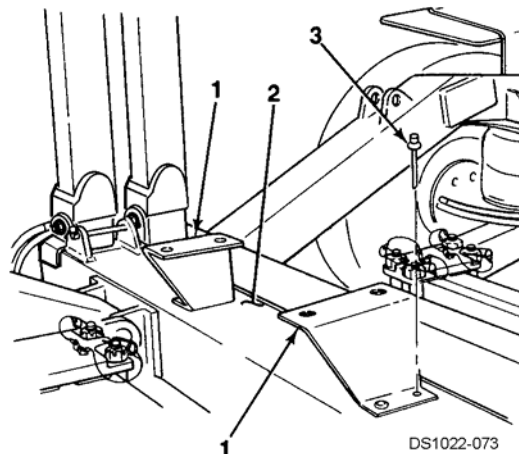
- General mechanic's tool kit (item 30, Appendix G)
  - Portable electric drill (Item 8, Appendix G)
  - Twist drill set (Item 9, Appendix G)
  - Blind hand riveter (Item 24, Appendix G)
- 

**a. REMOVAL**



**Wear eye protection when using electric drill to drill out rivets. Failure to follow this warning may cause serious eye injury to personnel.**

1. Drill out four rivets (3) from mounting brackets (1). Discard rivets.
2. Remove two mounting brackets (1) from bottom beam (2).



**b. INSTALLATION**

Install two mounting brackets (1) on bottom beam (2) with four new rivets (3).

**Follow-on Tasks:**

- Install toolbox (see paragraph 4-103).

**4-98. PIVOTING TRAY LOCKOUT BRACE AND UPPER AND LOWER BRACKETS REPLACEMENT.**

*This Task Covers:*

- a. Removal b. Installation

*Initial Setup:*

**Materials/Parts:**

- Five locknuts

**Tools/Test Equipment:**

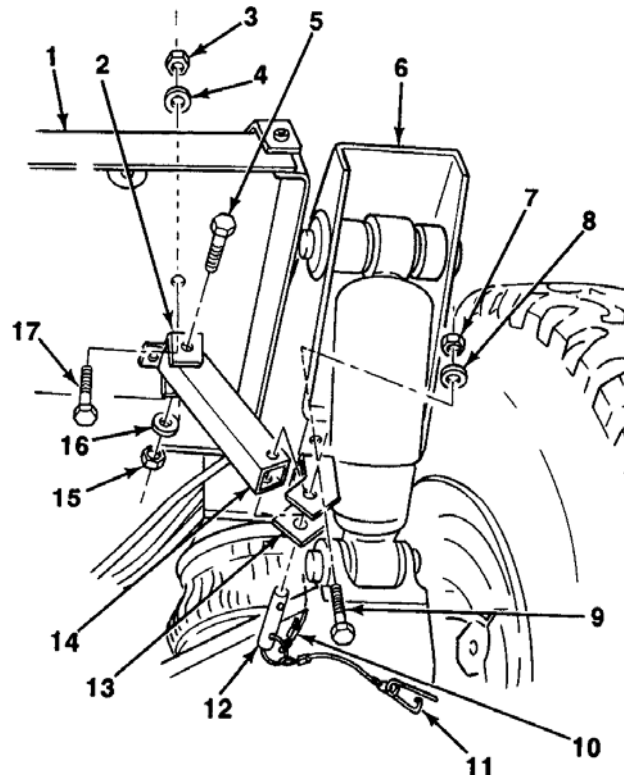
- General mechanic's tool kit (item 30, Appendix G)

**NOTE**

**Front and rear pivoting tray lockout braces and upper and lower brackets are replaced the same way except location of lockout brace varies on front and rear pivoting trays. Rear pivoting tray lockout brace and rear upper and lower brackets are illustrated.**

**a. REMOVAL**

1. Remove safety pin (11) and hitch pin (12) and unlock lockout brace (14) from lower bracket (13).
2. Remove locknut (15), flatwasher (16), capscrew (5), and lockout brace (14) from upper bracket (2). Discard locknut.
3. Remove two locknuts (3), flatwashers (4), bolts (17), and upper bracket (2) from pivoting tray (1). Discard locknuts.
4. Remove two locknuts (7), flatwashers (8), capscrews (9), and lower bracket (13) from suspension link (6). Discard locknuts.
5. If hitch pin (12) and safety pin (11) are damaged replace with lanyard assembly (10) (see paragraph 4-99).



---

**4-98. PIVOTING TRAY LOCKOUT BRACE AND UPPER AND LOWER BRACKETS REPLACEMENT (Con't).**

---

<b>b. INSTALLATION</b>
------------------------

1. If removed, install hitch pin (12) and safety pin (11) with lanyard assembly (10) (see paragraph 4-99).
2. Install lower bracket (13) on suspension link (6) with two capscrews (9), flatwashers (8), and new locknuts (7).
3. Install upper bracket (2) on pivoting tray (1) with two bolts (17), flatwashers (4), and new locknuts (3).
4. Install lockout brace (14) on upper bracket (2) with capscrew (5), flatwasher (16), and new locknut (15).
5. Lock lockout brace (14) to lower bracket (13) with hitch pin (12) and safety pin (11).

---

## 4-99. LANYARD ASSEMBLIES REPLACEMENT.

---

*This Task Covers:*

- a. Removal b. Installation
- 

*Initial Setup:*

**Materials/Parts:**

- One locknut (rear drawbar)
- One lockspring washer
- Two sleeves

**Tools/Test Equipment:**

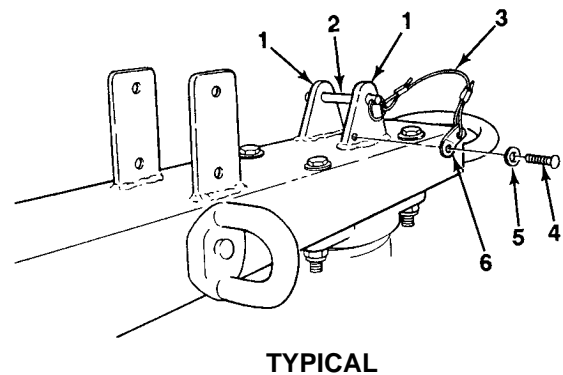
- General mechanic's tool kit (Item 30, Appendix G)
- 

**NOTE**

Lanyard assemblies that secure dolly set pins are replaced the same way except for lanyard assembly on rear drawbar which secures pin for caster wheel handle stowage. Mounting hardware for this lanyard assembly differs from the rest.

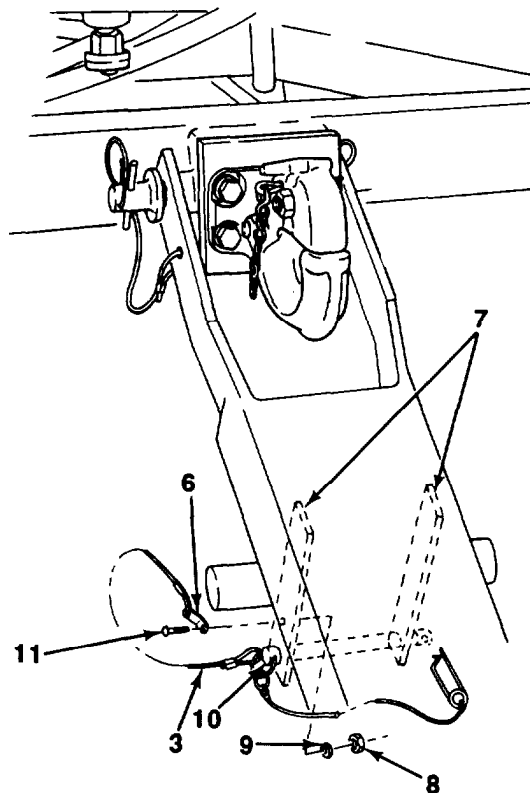
**a. REMOVAL**

1. Cut lanyard cable (3) from detent pin (2) or hitch pin (10).



**4-99. LANYARD ASSEMBLIES REPLACEMENT (Con't).**

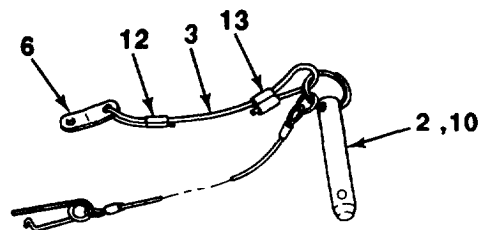
2. If removing lanyard assembly from rear drawbar that secures hitch pin (10), remove locknut (8), flatwasher (9) screw (11) and retainer (6) with lanyard cable (3) from bracket (7). Discard locknut and sleeves.
3. If removing all other lanyard assemblies, remove self-tapping screw (4) lockspring washer (5) and retainer (6) with lanyard cable (3) from mounting lug (1). Discard lockspring washer and sleeves.
4. If damaged, replace detent pin (2) or hitch pin (10).



**REAR DRAWBAR HANDLE STOWAGE**

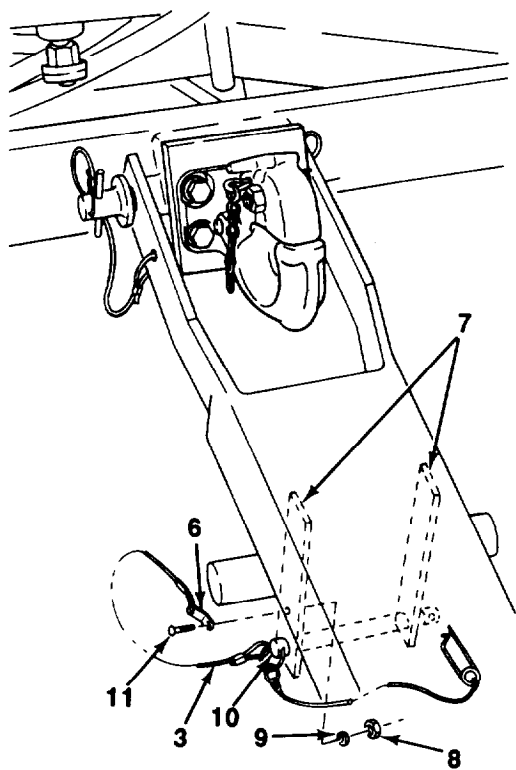
**b. INSTALLATION**

1. Secure lanyard cable (3) on detent pin (2) or hitch pin (10) with new sleeve (13). Crimp sleeve.
2. Secure lanyard cable (3) on retainer (6) with new sleeve (12). Crimp sleeve.

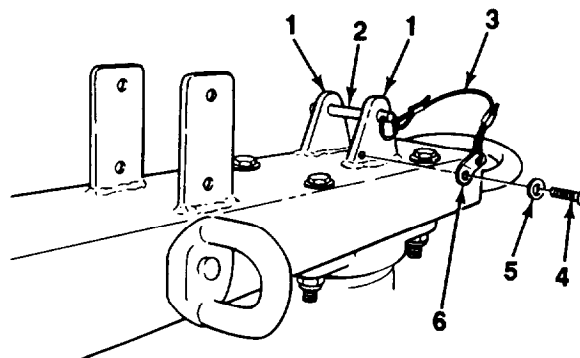


**4-99. LANYARD ASSEMBLIES REPLACEMENT (Con't).**

3. If installing lanyard assembly on rear drawbar that secures hitch pin (10), install retainer (6) with lanyard cable (3) on bracket (7) with screw (11), flatwasher (9) and new locknut (8).
4. If installing all other lanyard assemblies, install retainer (6) with lanyard cable (3) on mounting lug (1) with new lockspring washer (5) and self-tapping screw (4).
5. Install detent pin (2) or hitch pin (10) on mounting lugs (1) or brackets (7).



**REAR DRAWBAR HANDLE STOWAGE**



**TYPICAL**



---

**4-100. HANGER BRACKET REPLACEMENT.**

---

*This Task Covers:*

a. Removal

b. Installation

---

*Initial Setup:*

**Materials/Parts:**

- Two locknuts

**Tools/Test Equipment:**

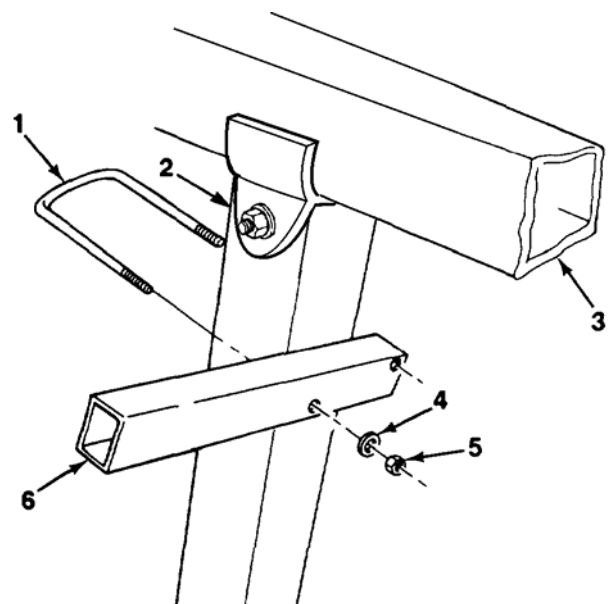
- General mechanic's tool kit (Item 30, Appendix G)
- 

**a. REMOVAL**

1. Remove stowed items from hanger bracket (6) as required.
2. Remove two locknuts (5), flatwashers (4), U-bolt (1), and hanger bracket (6) from top beam vertical tube (2). Discard locknuts.

**b. INSTALLATION**

1. Position hanger bracket (6) on top beam vertical tube (2), 6 in. (15.2 cm) below top beam (3). Install U-bolt (1), two flatwashers (4), and new locknuts (5).
2. Stow items on hanger bracket (6) as required.





**SECTION XII. SPRINGS AND SHOCK ABSORBERS MAINTENANCE**

Paragraph Number	Paragraph Title Number	Page
4-101.	Air Bag Replacement.....	4-255
4-102.	Front Drawbar Bushings Replacement.....	4-260

**4-101. AIR BAG REPLACEMENT.**

*This Task Covers:*

- |            |                 |
|------------|-----------------|
| a. Removal | b. Installation |
|------------|-----------------|

*Initial Setup:*

**Equipment Conditions:**

- Dolly set lowered, front and rear dollies detached (see paragraph 2-8).
- Steering locking pin installed in steering link.
- Shock absorbers removed from axle (see paragraph 4-102).

**Materials/Parts:**

- Sealing compound (Item 10, Appendix F)
- Two locknuts

**Tools/Test Equipment:**

- General mechanic's tool kit (item 30, Appendix G)
- Hydraulic jack, 12 ton (Item 17, Appendix G)
- Trestles (four) (Item 32, Appendix G)
- Torque wrench, 0-175 lb.-ft. (Item 42, Appendix G)
- Suitable support

**Personnel Required:** Two

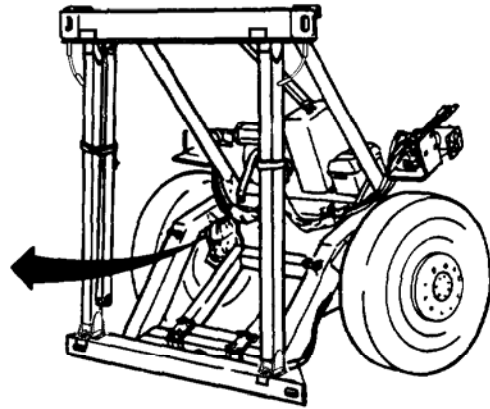
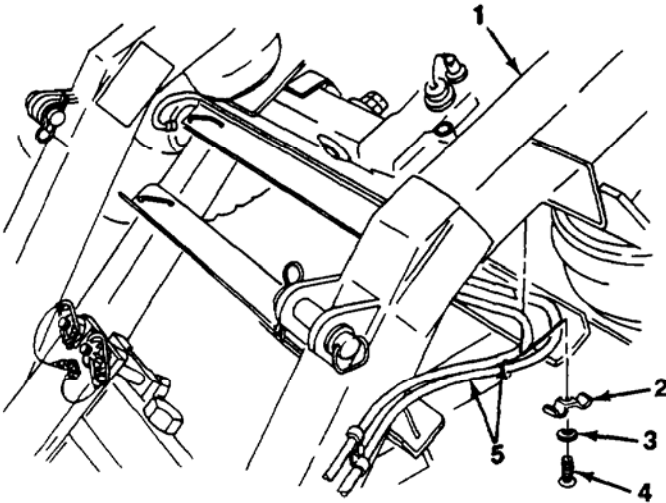
---

**4-101. AIR BAG REPLACEMENT (Cont).**

---

**a. REMOVAL**

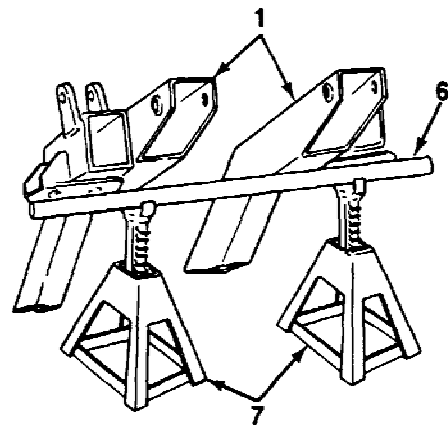
1. Remove self-tapping screw (4), flatwasher (3), hose clamp (2), and two hose assemblies (5) from underside of right side suspension link (1).



DS1022-075

**RIGHT SIDE**

2. Place a support (6) between two trestles (7) under suspension links (1) at point where suspension links bend.

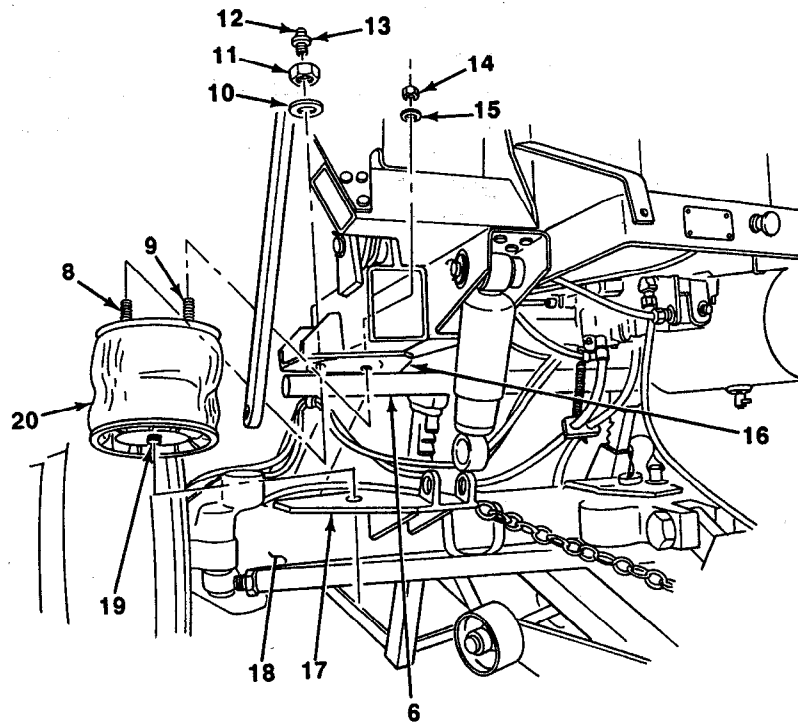


---

**4-101. AIR BAG REPLACEMENT (Con't).**

---

3. Raise axle assembly (18) and support with two trestles. Remove wheel and tire from each end of axle assembly (see paragraph 4-76).
4. Remove cap (12) and air bag valve (13) from stud (8).
5. Remove two locknuts (11 and 14) and flatwashers (10 and 15) from studs (8 and 9) at suspension link mounting plate (16). Discard locknuts.
6. Lower axle assembly (18) until studs (8 and 9) are clear of suspension link mounting plate (16).
7. Remove air bag (20) by turning air bag to remove stud (19) from axle mounting plate (17).



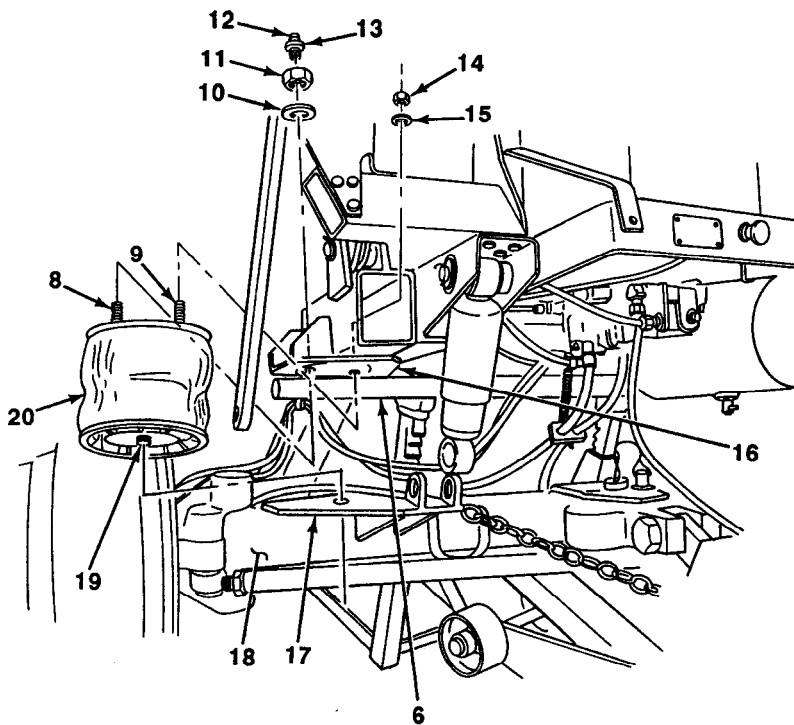
---

## 4-101. AIR BAG REPLACEMENT (Con't).

---

### b. INSTALLATION

1. Install stud (19) on axle mounting plate (17) and turn air bag (20).
2. Evenly raise axle assembly (18) until studs (8 and 9) are positioned through holes in suspension link mounting plate (16). Support axle with two trestles.
3. Remove support (6) from suspension links (1).
4. Install two flatwashers (10 and 15) and new locknuts (11 and 14) on studs (8 and 9). Torque locknuts to 25 lb.-ft. (34 N•m).

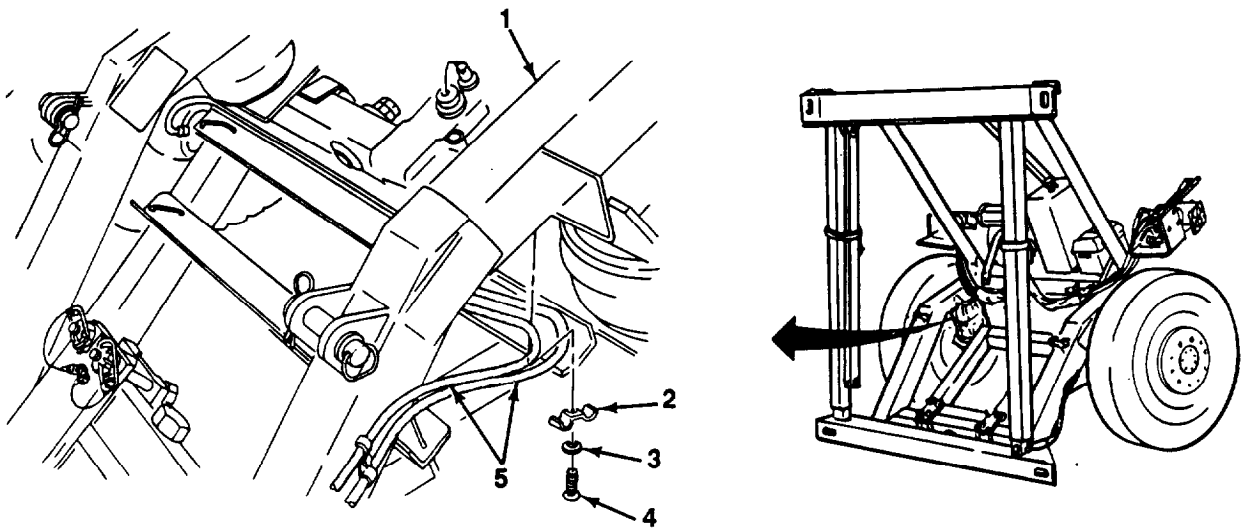


---

**4-101. AIR BAG REPLACEMENT (Con't).**

---

1. Install air bag valve (13) on stud (8) with sealing compound (see paragraph 4-16). Install cap (12) on air bag valve.
2. Install wheels and tires (see paragraph 4-76) on axle assembly (18).
3. Remove trestles from under axle assembly (18) and lower axle assembly.
4. install two hose assemblies (5) on underside of right side suspension link (1) with hose clamp (2), flatwasher (3), and self-tapping screw (4).

**RIGHT SIDE****Follow-on Tasks:**

- Install shock absorbers on axle (see paragraph 4-102).

---

## 4-102. SHOCK ABSORBER REPLACEMENT.

---

*This Task Covers:*

a. Removal

b. Installation

*Initial Setup:*

**Materials/Parts:**

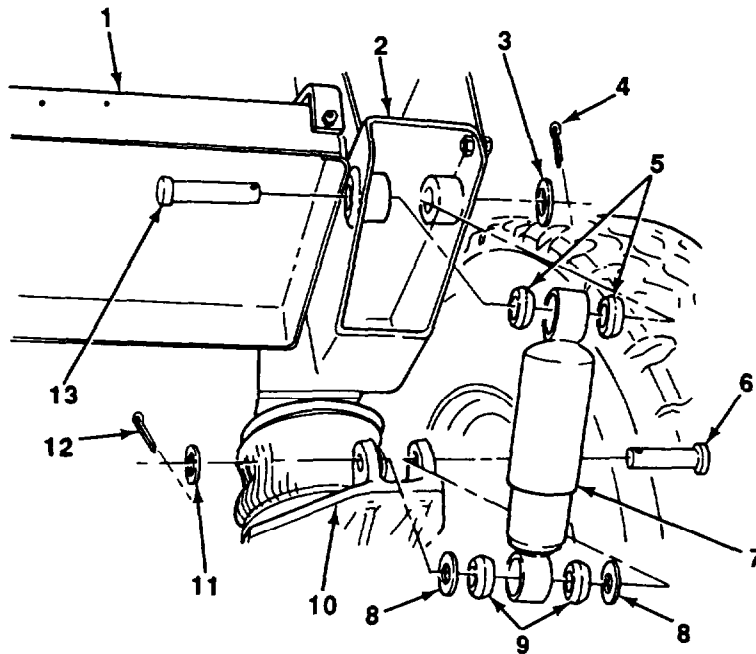
- Two cotter pins

**Tools/Test Equipment:**

- General mechanic's tool kit (Item 30, Appendix G)
- 

### **a. REMOVAL**

1. Remove cotter pin (12), flatwasher (11), clevis pin (6), shock absorber (7), two flatwashers (8), and bushings (9) from mounting lugs on axle assembly (10). Discard cotter pin.
2. Remove cotter pin (4) and flatwasher (3) from clevis pin (13). Discard cotter pin.
3. Unlock pivoting tray lockout brace (see paragraph 4-98) and tip pivoting tray (1) to gain access to clevis pin (13) as required.
4. Remove clevis pin (13), shock absorber (7), and two bushings (5) from suspension link (2).





---

**4-102. SHOCK ABSORBER REPLACEMENT (Con't).**

---

**b. INSTALLATION****NOTE**

**It may be necessary to paint ride height indicator ring on shock absorber. Use old shock absorber as a guide.**

1. Position shock absorber (7) four bushings (5 and 9), and two flatwashers (8) between mounting lugs on axle assembly (10) and suspension link (2).
2. Tip pivoting tray (1) as required to gain access.
3. Install shock absorber (7) on suspension link (2) with clevis pin (13) flatwasher (3) and new cotter pin (4). Lock pivoting tray lockout brace (see paragraph 4-98).
4. Install shock absorber (7) on mounting lugs on axle assembly (10) with clevis pin (6) flatwasher (11), and new cotter pin (12).



## Section XIII. BODY MAINTENANCE

### 4-103. TOOLBOX REPLACEMENT.

*This Task Covers:*

a. Removal

b. Installation

*Initial Setup:*

#### Materials/Parts:

- Four locknuts

#### Tools/Test Equipment:

- General mechanic's tool kit (Item 30, Appendix G)
- Torque wrench, 0-200 lb.-in. (Item 41, Appendix G)

#### NOTE

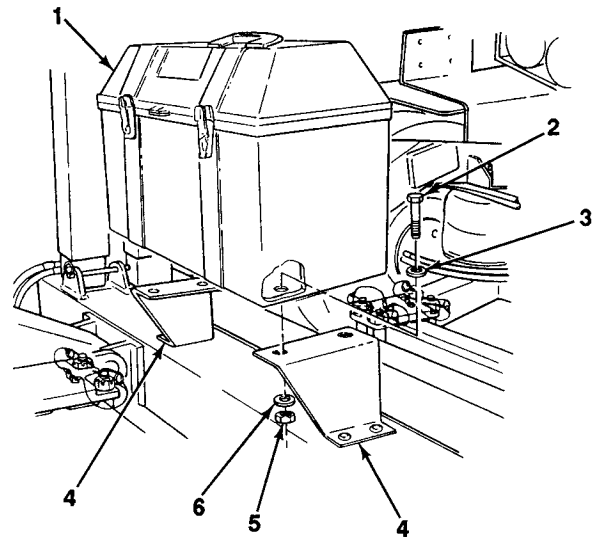
Note position of toolbox before removal. Toolbox **MUST** be installed in same position.

#### a. REMOVAL

1. Open toolbox (1) and remove contents.
2. Remove four locknuts (5), flatwashers (6), capscrews (2), packings with retainer (3), and toolbox (1) from mounting brackets (4). Discard locknuts.

#### b. INSTALLATION

1. Install toolbox (1) on mounting brackets (4) with four packings with retainer (3), capscrews (2), flatwashers (6), and new locknuts (5). Torque locknuts to 40 +/- 4 lb.-in. (4.52 +/- 0.45 N•m).
2. Place removed contents in toolbox (1) and close.





## Section XIV. ACCESSORY ITEMS MAINTENANCE

Paragraph Number	Paragraph Title	Page Number
4-104.	Reflector Replacement .....	4-265
4-105.	Data Plate Replacement .....	4-266
4-106.	Decal Replacement .....	4-267

### 4-104. REFLECTOR REPLACEMENT.

*This Task Covers:*

- |            |                 |
|------------|-----------------|
| a. Removal | b. Installation |
|------------|-----------------|

*Initial Setup:*

**Materials/Parts:**

- Two locknuts

**Tools/Test Equipment:**

- General mechanic's tool kit (Item 30, Appendix G)

*NOTE*

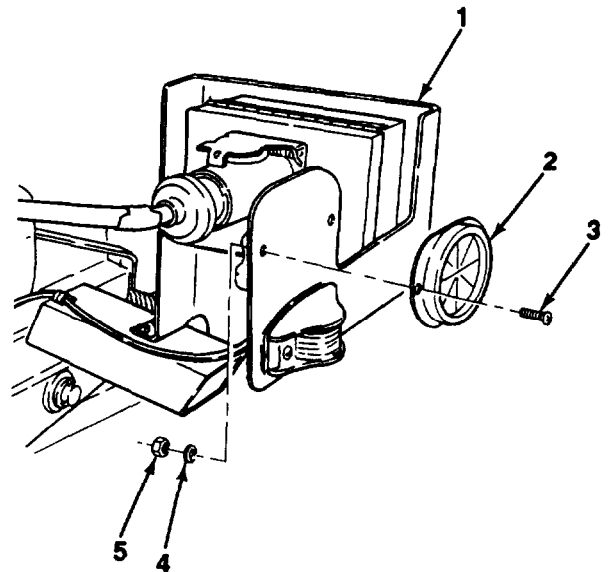
- All reflectors are replaced the same way. Front dolly right side reflector replacement is illustrated.
- Amber reflectors are located on front dolly; red reflectors are located on rear dolly.

**a. REMOVAL**

Remove two locknuts (5), flatwashers (4), screws (3), and reflector (2) from bracket (1). Discard locknuts.

**b. INSTALLATION**

install reflector (2) on bracket (1) with two screws (3), flatwashers (4), and new locknuts (5).



---

## 4-105. DATA PLATE REPLACEMENT.

---

*This Task Covers:*

- a. Removal b. Installation
- 

*Initial Setup:*

**Materials/Parts:**

- Drive screws

**Tools/Test Equipment:**

- General mechanic's tool kit (Item 30, Appendix G)
- 

### NOTE

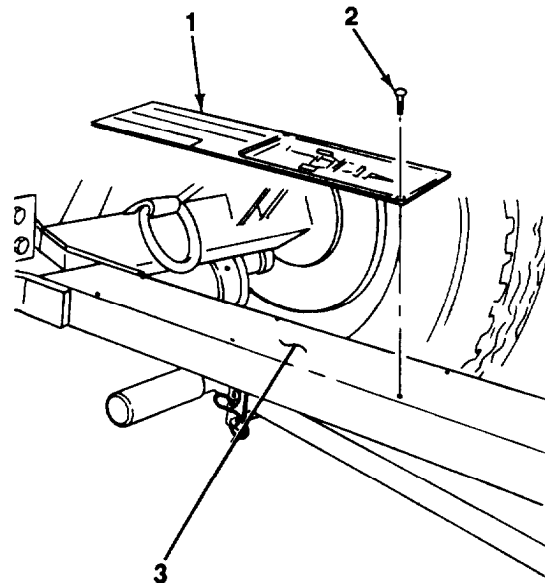
All data plates are replaced the same way. Lubrication chart data plate is Illustrated.

#### **a. REMOVAL**

Remove drive screws (2) from data plate (1) and mounting surface (3). Discard drive screws.

#### **b. INSTALLATION**

Install data plate (1) on mounting surface (3) with new drive screws (2).



---

**4-106. DECAL REPLACEMENT.**

---

*This Task Covers:*

- a. Removal
- b. Cleaning
- c. Installation

*Initial Setup:*

**Materials/Parts:**

- Rags (Item 25, Appendix F)
- Dry cleaning solvent (Item 27, Appendix F)

**Tools/Test Equipment:**

- General mechanic's tool kit (Item 30, Appendix G)

**General Safety Instructions:**

- Dry cleaning solvent is flammable and must not be used near an open flame. Use only in a well-ventilated area.

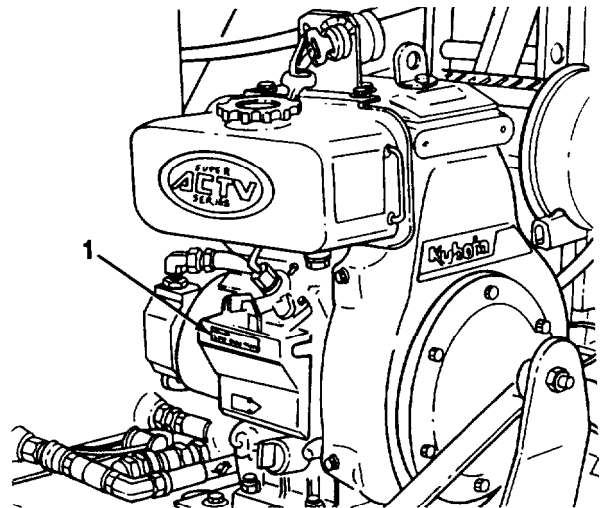
---

**NOTE**

All decals are replaced the same way. Engine speed control lever decal is illustrated.

**a. REMOVAL**

Use a pocket knife or putty knife to scrape off decal (1).



---

## 4-106. DECAL REPLACEMENT (Con't).

---

### **b. CLEANING**

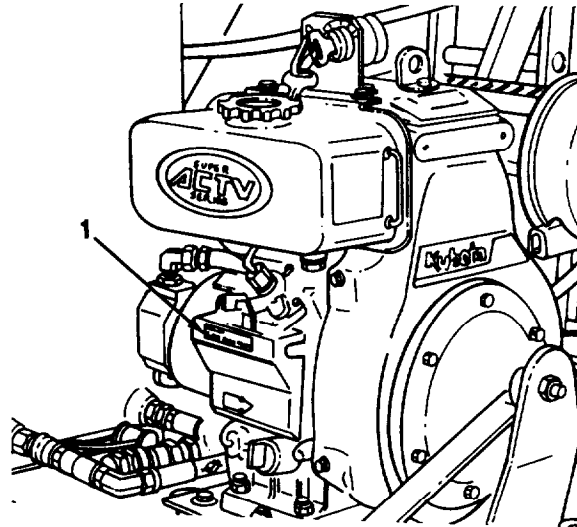
#### **WARNING**

Dry cleaning solvent, P-D-680, is toxic and flammable. Always wear protective goggles and gloves, and use only in a well-ventilated area. Avoid contact with skin, eyes, and clothes, and DO NOT breathe vapors. DO NOT use near open flame or excessive heat. The solvent's flash point is 100°F-1380F (38°C-590C). If you become dizzy while using cleaning solvent, immediately get fresh air and medical help. If solvent contacts eyes, immediately wash your eyes and seek medical attention.

Clean adhesive and dirt from mounting surface with dry cleaning solvent and dry with a clean rag.

### **c. INSTALLATION**

1. Remove backing from decal (1).
2. Place decal (1) on mounting surface. Press firmly to remove air bubbles and to secure.





## Section XV. HYDRAULIC SYSTEM MAINTENANCE

Paragraph Number	Paragraph Title	Page Number
4-107.	Hydraulic Pump Maintenance. . . . .	4-269
4-108.	Hydraulic Control Valve Replacement . . . . .	4-274
4-109.	Hydraulic Lines Replacement. . . . .	4-287
4-110.	Hydraulic Lift Cylinder Replacement . . . . .	4-301
4-111.	Hydraulic Reservoir and Redundant Power Fittings Replacement. . . . .	4-305
4-112.	Hydraulic System Bleeding. . . . .	4-312
4-113.	Hydraulic System Bleeding (M1022A1 With Side Lift Kit . . . . .	4-315
4-114.	Hydraulic System Schematics . . . . .	4-324

**NOTE**

**Hydraulic positioning cylinders are located inside top and bottom beam telescoping vertical tubes. Refer to paragraph 4-83 for positioning cylinders replacement.**

---

### 4-107. HYDRAULIC PUMP MAINTENANCE.

---

*This Task Covers:*

- |  |  |
|--|--|
| <ul style="list-style-type: none"> <li>a. Removal</li> <li>b. Disassembly</li> <li>c. Cleaning and Inspection</li> </ul> | <ul style="list-style-type: none"> <li>d. Assembly</li> <li>e. Installation</li> </ul> |
|--|--|

*Initial Setup:*

**Equipment Conditions:**

- Dolly set lowered (see paragraph 2-8)
- Engine starter switch set to OFF position (see paragraph 2-20)

**Tools/Test Equipment:**

- General mechanic's tool kit (Item 30, Appendix G)
- Wrench, torque, 0-200 lb.-in. (Item 41, Appendix G)

**Materials/Parts:**

- Hydraulic fluid (Item 15, Appendix F)
- Grease (Item 19 Appendix F)
- Rags (Item 25, Appendix F)
- Marker tags (Item 28, Appendix F)
- Masking tape, 2 in. (Item 32, Appendix F)
- One seal
- Two preformed packings
- Eight lockwashers

**WARRANTY NOTICE**

*A one-time extended warranty is in effect on hydraulic pumps if found to be leaking within 18 months after shipped from factory. This warranty applies to all units whose 8 digit serial number begins with numbers 107 to 484. If pumps are found to be leaking and have not been previously replaced under warranty, contact Engineered Systems (2550 Market Street, Aston, PA 19014-3426, U.S.A., telephone number (610) 494-8000, extension 261, or fax (610) 494-8989) to verify system serial number and to obtain shipping instructions for faulty pump and its replacement.*

---

## 4-107. HYDRAULIC PUMP MAINTENANCE (Con't).

---

a. <b>REMOVAL</b>
-------------------

<b>WARNING</b>
----------------

- **DO NOT** disconnect hydraulic lines and fittings while engine is running or before hydraulic system pressure has been released. When engine is running, hydraulic system is under pressure. Dolly set must be fully lowered to the ground and engine must be shut down before lines and fittings are disconnected. A line or fitting disconnected under pressure will explode with great force and cause serious injury or death to personnel.
- Escaping hydraulic fluid under pressure can penetrate the skin, causing serious injury to personnel. Relieve pressure before disconnecting hydraulic lines and fittings. Tighten all connections before applying pressure. Keep hands and body away from pinholes and nozzles which eject hydraulic fluid under high pressure. Use a piece of cardboard or paper to search for leaks. If any hydraulic fluid is injected into the skin, it **MUST** be surgically removed within a few hours by a doctor familiar with this type of injury or gangrene may result.

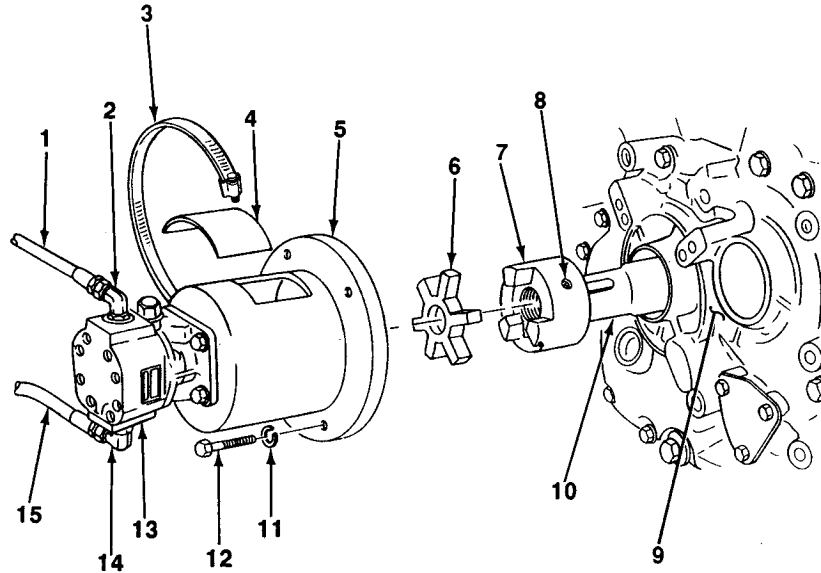
**NOTE**

- Hydraulic lines should be tagged before removal. Refer to paragraph 4-18 for tagging instructions.
  - Hydraulic pump ports should be plugged with masking tape or other suitable means as lines are disconnected or fittings are removed. Refer to paragraph 4-22 for instructions.
  - A suitable container should be used to catch any draining hydraulic fluid. Ensure that all spills are properly cleaned.
1. Disconnect hose assembly (1) from elbow (2) at inlet (top) of hydraulic pump (13). Drain hydraulic fluid into a suitable container.
  2. Disconnect hose assembly (15) from elbow (14) at outlet (bottom) of hydraulic pump (13). Drain hydraulic fluid into a suitable container.
  3. Remove clamp (3) and access cover (4) from adapter (5).
  4. Remove four capscrews (12), lockwashers (11), and adapter (5) with hydraulic pump (13) from engine (9). Discard lockwashers.
  5. Remove spider (6) from engine coupling half (7).
  6. If engine coupling half (7) is damaged, loosen setscrew (8) and remove engine coupling half from crankshaft (10).
  7. Loosen setscrew (19) from hydraulic pump coupling half (18).

---

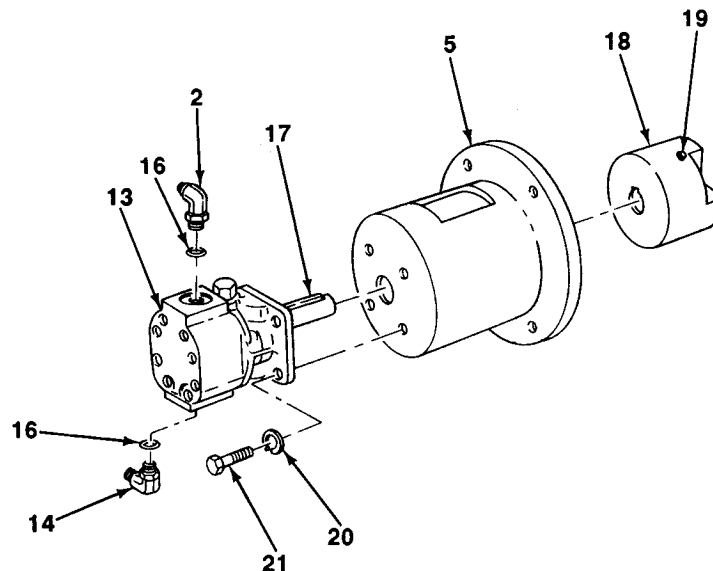
**4-107. HYDRAULIC PUMP REPLACEMENT (Con't).**


---

**NOTE**

**Note and mark position of hydraulic pump on adapter to aid during installation.**

8. Remove four bolts (21), lockwashers (20), hydraulic pump (13), and hydraulic pump coupling half (18) from adapter (5). Discard lockwashers.
9. Remove two elbows (2 and 14) and preformed packings (16) from hydraulic pump (13). Discard preformed packings.



## 4-107. HYDRAULIC PUMP MAINTENANCE (Con't).

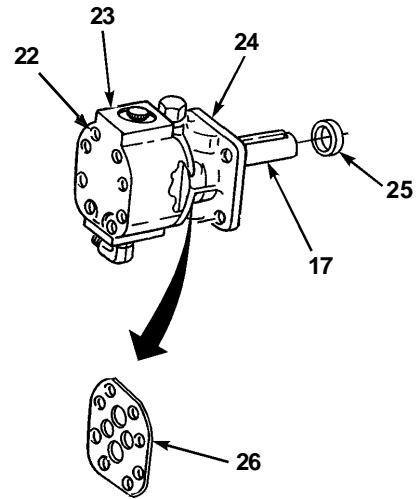
### b. DISASSEMBLY

1. Remove eight screws (22).
2. Separate pump halves (23 and 24).
3. Inspect seal/shim (26) for damage. Retain if not damaged.
4. Separate pump shaft (17) from pump half (24).

#### CAUTION

**Use caution not to damage housing of pump half.**

5. Remove seal (25) from pump half (24). Discard seal



### c. CLEANING AND INSPECTION

1. Clean all removed components with a clean rag.
2. Inspect all components for cracks, breaks, bends, corrosion, or damaged threads. Replace damaged components.

### d. ASSEMBLY

1. Lightly tap new seal (25) into pump half (24).

#### CAUTION

**Use caution when inserting pump shaft into pump half. Damage to seal could result.**

2. Insert pump shaft (17) into pump half (24) and through seal (25).

#### NOTE

**If a replacement seal/shim is required, obtain from seal kit P/N 2300622. Replace seal/shim color for color, to ensure pump gear internal clearances are maintained.**

3. Assemble pump half (23), seal/shim (26), and pump half (24). Secure with eight screws (22).
4. Torque screws (22) to 114-150 lb.-in. (13-17 N•m).

### e. INSTALLATION

#### NOTE

**Preformed packings should be lightly coated with hydraulic fluid before installation.**

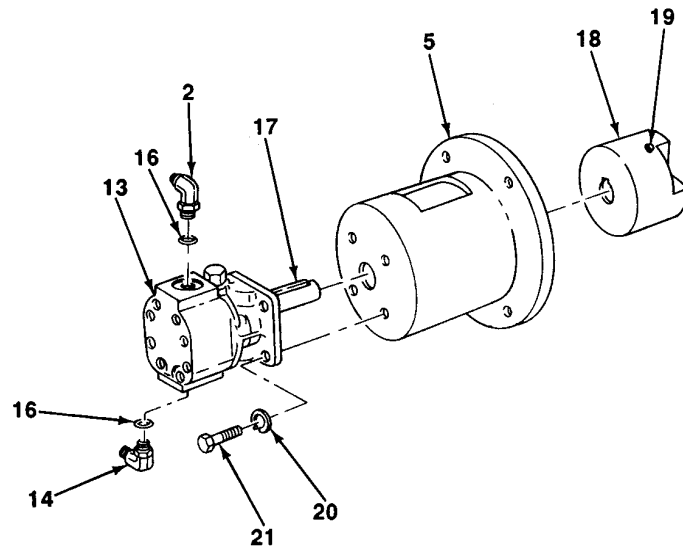
1. Install two new preformed packings (16) and elbows (2 and 14) on hydraulic pump (13).

#### NOTE

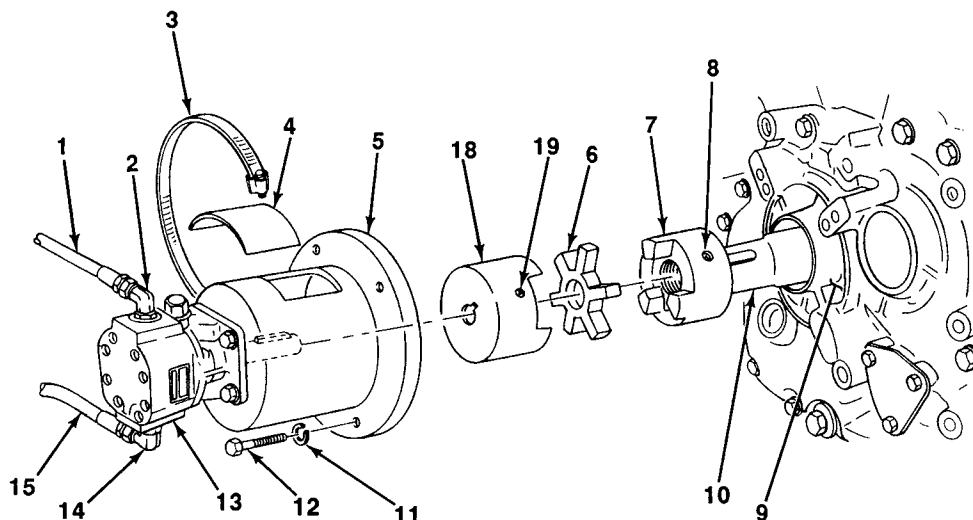
**Hydraulic pump should be installed with inlet (suction) port at top and aligned with top of adapter. Access cover opening of adapter will also be facing up.**

2. Install hydraulic pump (13) on adapter (5) with four new lockwashers (20) and bolts (21).
3. Coat pump shaft (17) with grease. Install hydraulic pump coupling half (18) on pump shaft with keyways engaged. Tighten setscrew (19).

## 4-107. HYDRAULIC PUMP MAINTENANCE (Con't).



4. Coat crankshaft (10) with grease. If removed, install engine coupling half (7) until flush with end of crankshaft. Ensure that keyways are engaged. Tighten setscrew (8).
5. Install spider (6) on engine coupling half (7).
6. Position adapter (5) with hydraulic pump (13) at engine (9) and engage hydraulic pump coupling half (18) with spider (6). Rotate adapter until hole for access cover (4) is at top. Install four new lockwashers (11) and capscrews (12).
7. Install access cover (4) on adapter (5) and secure with clamp (3).
8. Connect hose assembly (15) to elbow (14) at outlet (bottom) of hydraulic pump (13).
9. Connect hose assembly (1) to elbow (2) at inlet (top) of hydraulic pump (13).



### **FOLLOW-ON TASKS:**

- Fill hydraulic reservoir with hydraulic fluid (see paragraph 3-7).
- Operate engine (see paragraph 2-20) and check operation of lift and positioning cylinders (see paragraph 2-21).
- Check for leaks.

---

## 4-108. HYDRAULIC CONTROL VALVE REPLACEMENT.

---

*This Task Covers:*

- a. Removal (Front Dolly)
- b. Removal (Rear Dolly)
- c. Cleaning and Inspection
- d. Installation (Rear Dolly)
- e. Installation (Front Dolly)

---

*Initial Setup:*

**Equipment Conditions:**

- Dolly set lowered (see paragraph 2-8).
- Engine starter switch set to OFF position (see paragraph 2-20)

**Tools/Test Equipment:**

- General mechanic's tool kit (item 30, Appendix G)
- Machinist's vise (Item 36, Appendix G)

**Materials/Parts:**

- Hydraulic fluid (Item 15, Appendix F)
- Rags (Item 25, Appendix F)
- Marker tags (Item 28, Appendix F)
- Masking tape, 2 in. (Item 32, Appendix F)
- Tie-down straps
- Three lockwashers
- Eleven preformed packings (rear dolly)
- Thirteen preformed packings (front dolly)

---

**WARNING**

- **DO NOT disconnect hydraulic lines and fittings while engine is running or before hydraulic system pressure has been released. When engine is running, hydraulic system is under pressure. Dolly set must be fully lowered to the ground and engine must be shut down before lines and fittings are disconnected. A line or fitting disconnected under pressure will explode with great force and cause serious injury or death to personnel.**
- **Escaping hydraulic fluid under pressure can penetrate the skin, causing serious injury to personnel. Relieve pressure before disconnecting hydraulic lines and fittings. Tighten all connections before applying pressure. Keep hands and body away from pinholes and nozzles which eject hydraulic fluid under high pressure. Use a piece of cardboard or paper to search for leaks. If any hydraulic fluid is injected into the skin, it MUST be surgically removed within a few hours by a doctor familiar with this type of injury or gangrene may result.**

**NOTE**

- **Hydraulic lines should be tagged before removal. Refer to paragraph 4-18 for tagging instructions.**
- **Hydraulic control valve ports should be plugged with masking tape or other suitable means as lines are disconnected or fittings are removed. Refer to paragraph 4-22 for instructions.**

---

**4-108. HYDRAULIC CONTROL VALVE REPLACEMENT (Con't).**

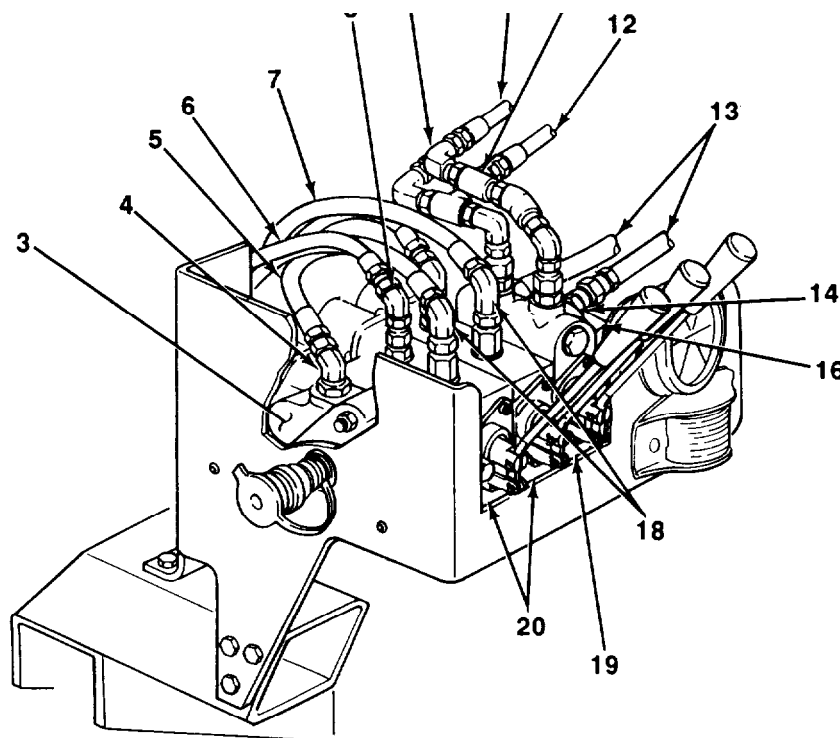

---

**NOTE**

- A suitable container should be used to catch any draining hydraulic fluid. Ensure that oil spills are properly cleaned.
- Tie-down straps must be removed from hydraulic hose assemblies and electrical cable assembly during removal. Ensure that new tie-down straps are used during Installation.

**a. REMOVAL (FRONT DOLLY)**

1. Disconnect hose assembly (5) from elbow (4) at inlet section (3).
2. Disconnect two hose assemblies (13) from unions (14) at outlet section (16).
3. Disconnect two hose assemblies (7) from long elbows (18) at two lift cylinder work sections (20).
4. Disconnect two hose assemblies (6) from swivel nut elbows (8) at two lift cylinder work sections (20).
5. Disconnect two hose assemblies (10) from swivel nut elbows (9) at positioning cylinders work section (19).
6. Disconnect two hose assemblies (12) from swivel nut tees (11) at positioning cylinders work section (19).

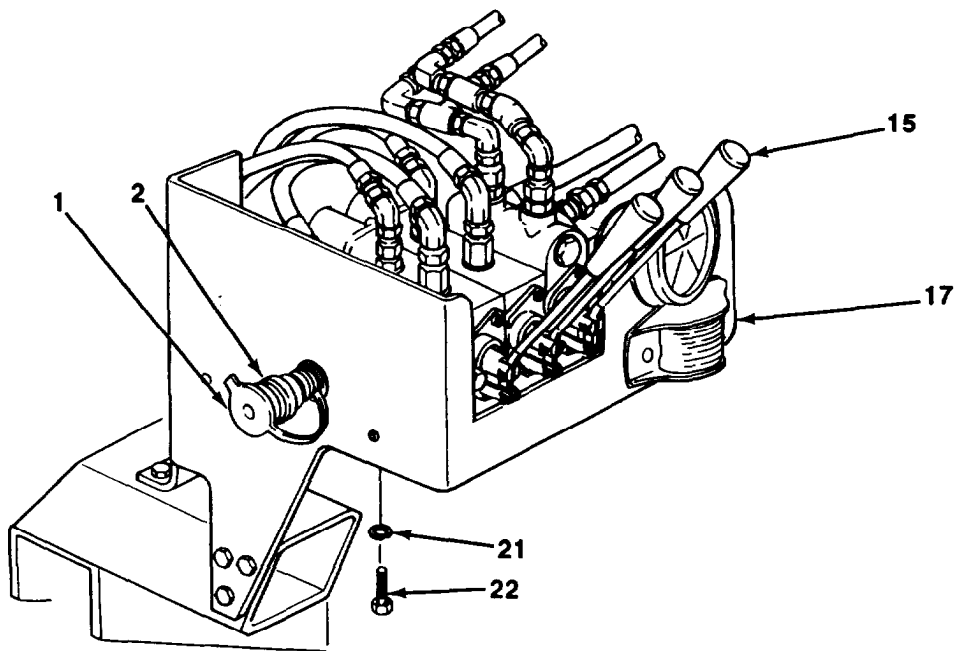
**FRONT DOLLY**

---

**4-108. HYDRAULIC CONTROL VALVE REPLACEMENT (Con't).**

---

7. Remove dust plug (1) from redundant power quick disconnect coupler (2).
8. Remove three cap screws (22), lockwashers (21), and hydraulic control valve (15) with fittings from bracket (17).



**FRONT DOLLY**

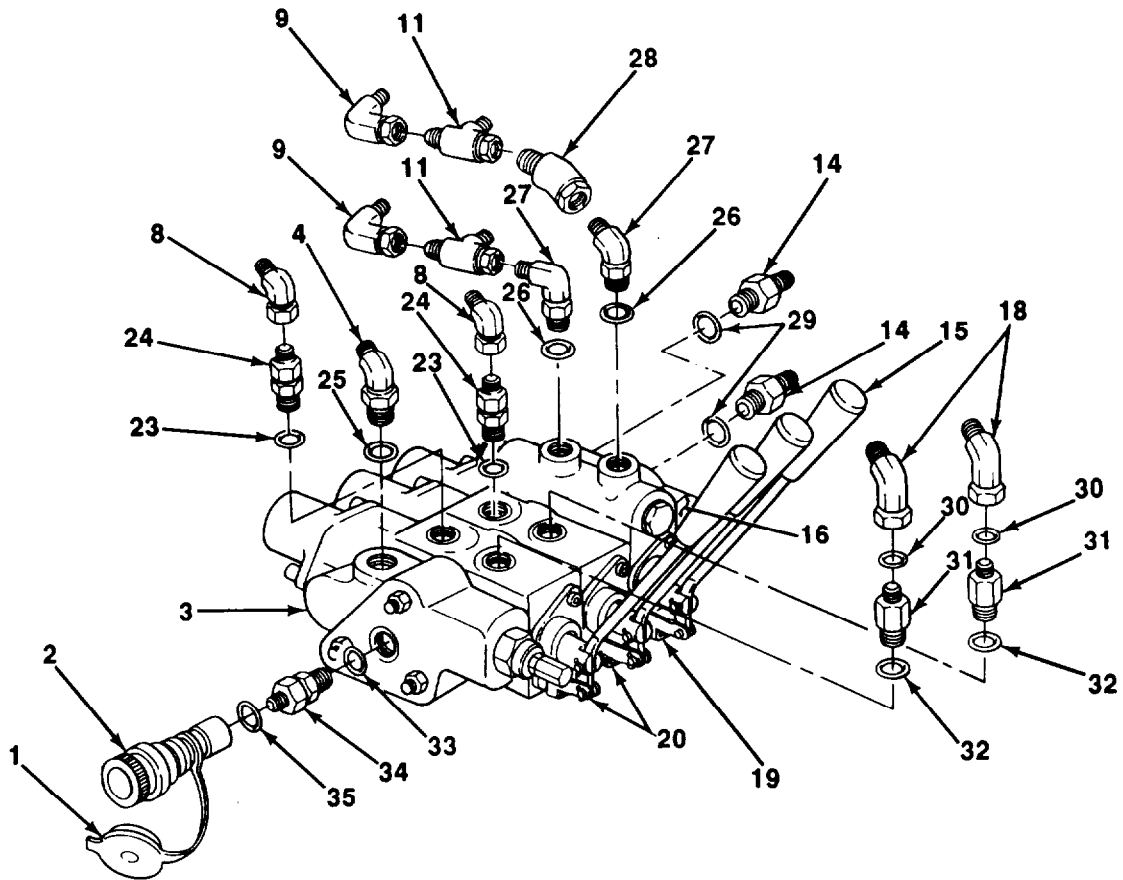


---

**4-108. HYDRAULIC CONTROL VALVE REPLACEMENT (Con't).**


---

9. Place hydraulic control valve (15) in a vise.
10. Remove elbow (4) preformed packing (25), redundant power quick disconnect coupler (2), dust plug (1) preformed packing (35) union (34), and preformed packing (33) from inlet section (3). Discard preformed packings.
11. Remove two unions (14) and preformed packings (29) from outlet section (16). Discard preformed packings.
12. Remove two long elbows (18) preformed packings (30) reducers (31) and preformed packings (32) from lift cylinder work sections (26). Discard preformed packings.
13. Remove two swivel nut elbows (8) straight adapters (24) and preformed packings (23) from lift cylinder work sections (20). Discard preformed packings.
14. Remove two swivel nut elbows (9) swivel nut tees (11), 45° swivel nut elbow (28) (top port only), two elbows (27), and preformed packings (26) from positioning cylinders work section (19). Discard preformed packings.
15. Remove hydraulic control valve (15) from vise.



**FRONT DOLLY**

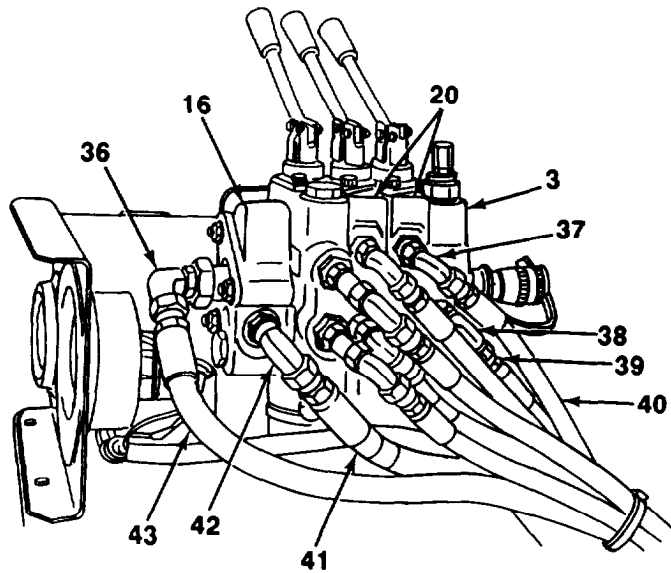
---

4-108. HYDRAULIC CONTROL VALVE REPLACEMENT (Con't).

---

**b. REMOVAL (REAR DOLLY)**

1. Disconnect hose assembly (39) from elbow (38) at inlet section (3).
2. Disconnect two hose assemblies (41 and 43) from swivel nut elbow (42) and elbow (36) at outlet section (16).
3. Disconnect four hose assemblies (40) from swivel nut elbows (37) at two lift cylinder work sections (20).



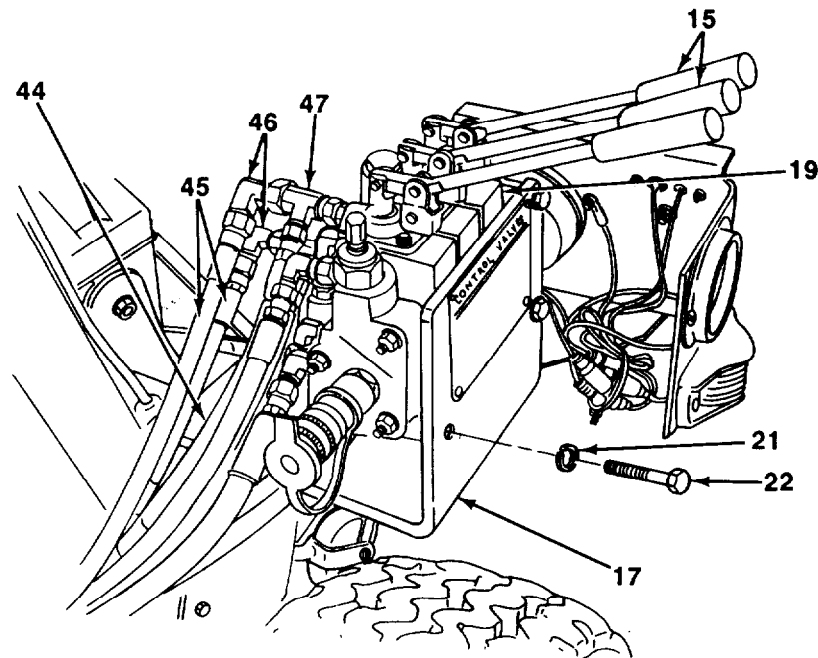
**REAR DOLLY**

---

**4-108. HYDRAULIC CONTROL VALVE REPLACEMENT (Con't).**

---

4. Disconnect two hose assemblies (45) from swivel nut elbows (46) at positioning cylinders work section (19).
5. Disconnect two hose assemblies (44) from swivel nut tees (47) at positioning cylinders work section (19).
6. Remove three capscrews (22), lockwashers (21), and hydraulic control valve (15) with fittings from bracket (17). Discard lockwashers.
7. Place hydraulic control valve (15) in a vise.

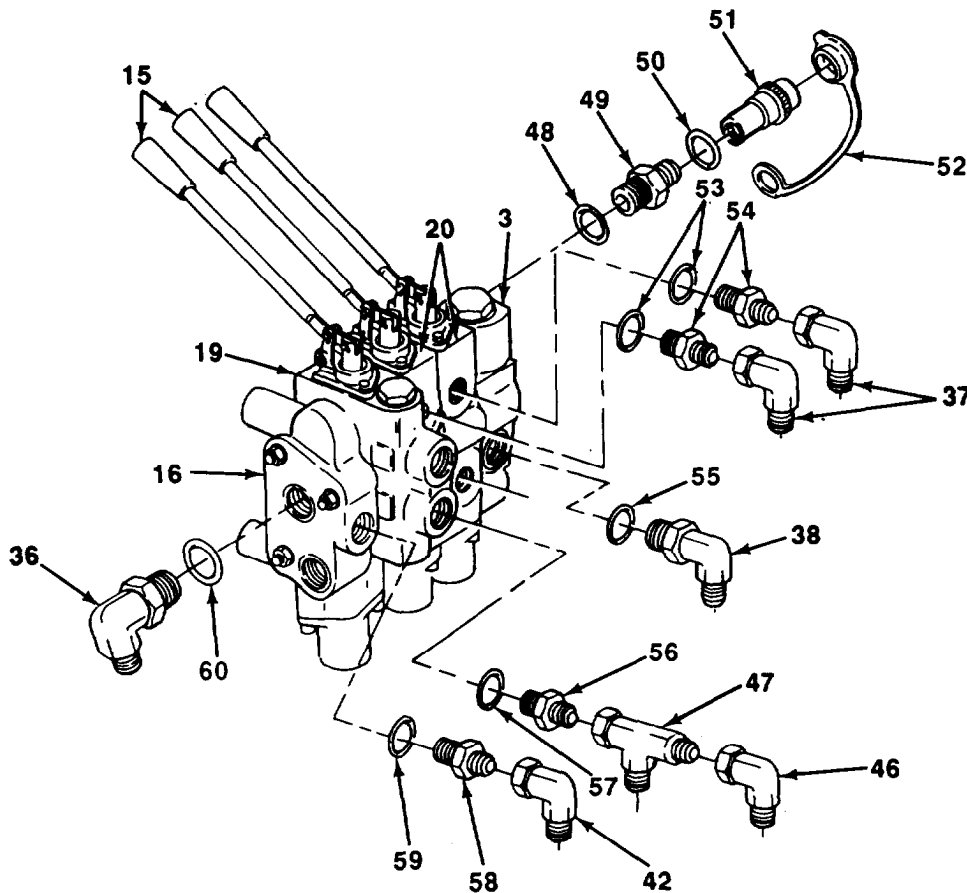
**REAR DOLLY**

---

**4-108. HYDRAULIC CONTROL VALVE REPLACEMENT (Con't).**

---

8. Remove dust plug (52), redundant power quick disconnect coupler (51) preformed packing (60) straight adapter (49) and preformed packing (48), elbow (38) and preformed packing (55) from inlet section (3). Discard preformed packings.
9. Remove swivel nut elbow (42), straight adapter (58), preformed packing (59), elbow (36) and preformed packing (60) from outlet section (16). Discard preformed packings.
10. Remove four swivel nut elbows (37) straight adapters (54), and preformed packings (63) from lift cylinder work sections (26). Discard preformed packings.
11. Remove two swivel nut elbows (46), swivel nut tees (47) straight adapters (56), and preformed packings (57) from positioning cylinders work section (19). Discard preformed packings.
12. Remove hydraulic control valve (15) from Vise.



**REAR DOLLY**

---

**4-108. HYDRAULIC CONTROL VALVE REPLACEMENT (Con't).**

---

**c. CLEANING AND INSPECTION**

1. Clean all removed components with a clean rag.
2. Inspect all components for cracks, breaks, bends, corrosion, or damaged threads. Replace damaged components.

**d. INSTALLATION (REAR DOLLY)****NOTE**

Preformed packings should be lightly coated with hydraulic fluid before installation.

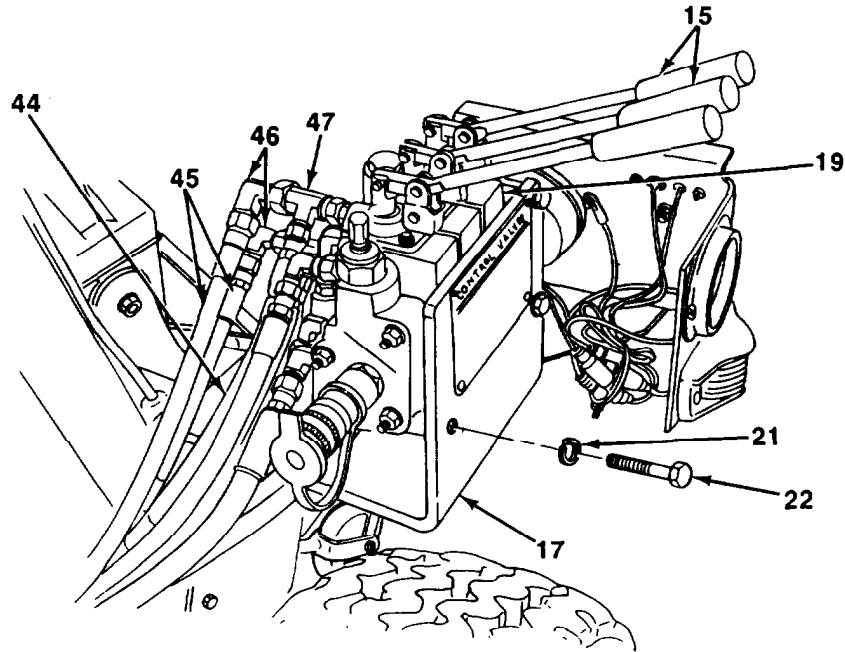
1. Place hydraulic control valve (15) in a vise.
2. Install two new preformed packings (57) and straight adapters (56) on positioning cylinders work section (19). Loosely install two swivel nut tees (47) and swivel nut elbows (46).
3. Install four new preformed packings (53) and straight adapters (54) on lift cylinder work sections (29). Loosely install four swivel nut elbows (37).
4. Install new preformed packing (48) straight adapter (49) new preformed packing (50) redundant power quick disconnect coupler (51) and dust plug (52) on inlet section (3). Install new preformed packing (55) and elbow (30)
5. install new preformed packing (60) elbow (36) new preformed packing (59) straight adapter (58) and swivel nut elbow (42) on outlet section (16). DO NOT fully tighten swivel nut elbow.
6. Remove hydraulic control valve (15) with fittings from vise.

---

**4-108. HYDRAULIC CONTROL VALVE REPLACEMENT (Con't).**

---

7. Install hydraulic control valve (15) with fittings to bracket (17) with three new lockwashers (21) and capscrews (22).
8. Connect two hose assemblies (44) to swivel nut tees (47) at positioning cylinders work section (19). Connect two hose assemblies (45) to swivel nut elbows (46). Fully tighten swivel nut tees and elbows.



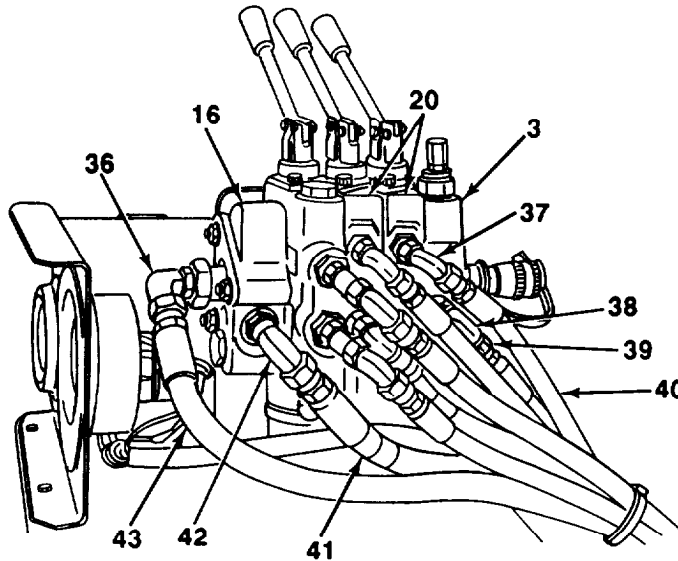
**REAR DOLLY**

---

**4-108. HYDRAULIC CONTROL VALVE REPLACEMENT (Con't).**

---

9. Connect four hose assemblies (40) to swivel nut elbows (37) at lift cylinder work sections (20). Fully tighten swivel nut elbows.
10. Connect two hose assemblies (41 and 43) to swivel nut elbow (42) and elbow (36) at outlet section (16). Fully tighten swivel nut elbow.
11. Connect hose assembly (39) to elbow (38) at inlet section (3).

**REAR DOLLY**

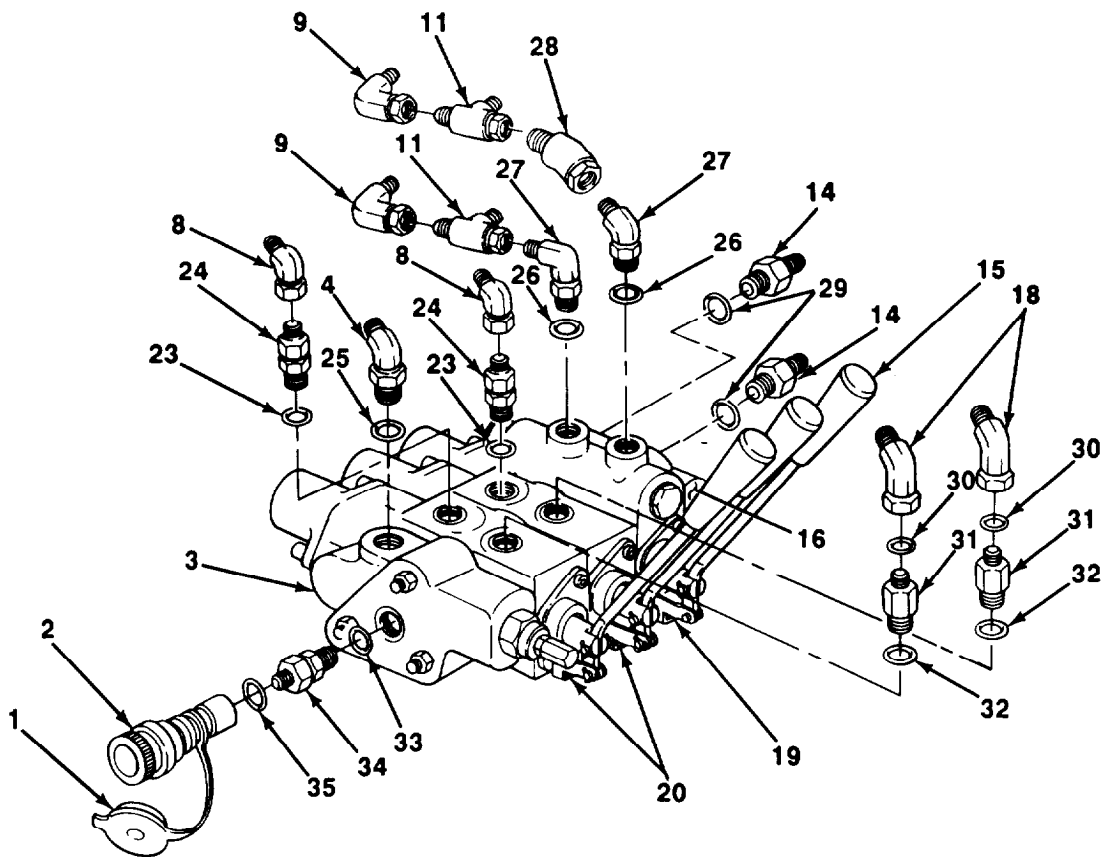
4-108. HYDRAULIC CONTROL VALVE REPLACEMENT (Con't).

**e. INSTALLATION (FRONT DOLLY)**

NOTE

Preformed packings should be lightly coated with hydraulic fluid before installation.

1. Place hydraulic control valve (15) in a vise.
2. Install two new preformed packings (26) and elbows (27) on positioning cylinders work section (19). Loosely install 45° swivel nut elbow (28) (top port only), two swivel nut tees (11), and swivel nut elbows (9).
3. Install two new preformed packings (23) and straight adapters (24) on lift cylinder work sections (20). Loosely install two swivel nut elbows (8).
4. Install two new preformed packings (32), reducers (31) new preformed packings (30), and long elbows (18) on lift cylinder work sections (20).
5. Install two new preformed packings (29) and unions (14) on outlet section (16).
6. Install new preformed packing (33) union (34), dust plug (1) new preformed packing (35), and redundant power quick disconnect coupler (2) on inlet section (3). Install new preformed packing (25) and elbow (4).



FRONT DOLLY

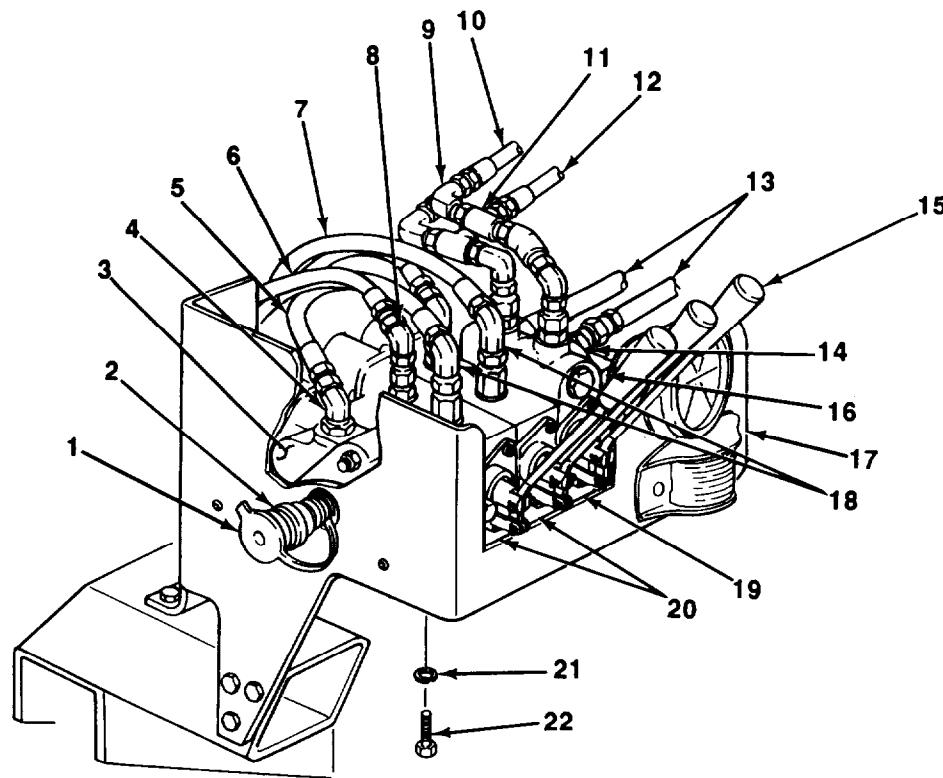


---

**4-108. HYDRAULIC CONTROL VALVE REPLACEMENT (Con't).**


---

7. Remove hydraulic control valve (15) with fittings from vise.
8. Install hydraulic control valve (15) with fittings on bracket (17) with three new lockwashers (21) and capscrews (22).
9. Install dust plug (1) on redundant power quick disconnect coupler (2).



**FRONT DOLLY**

10. Connect two hose assemblies (12) to swivel nut tees (11) at positioning cylinders work section (19). Connect two hose assemblies (10) to swivel nut elbows (9). Fully tighten swivel nut tees and elbows.
11. Connect two hose assemblies (6) to swivel nut elbows (8) at two lift cylinder work sections (20).
12. Connect two hose assemblies (7) to long elbows (18) at two lift cylinder work sections (20).
13. Connect two hose assemblies (13) to unions (14) at outlet section (16).
14. Connect hose assembly (5) to elbow (4) at Inlet section (3).

---

#### 4-108. HYDRAULIC CONTROL VALVE REPLACEMENT (Con't).

---

**Follow-on Tasks:**

- Fill hydraulic reservoir with hydraulic fluid (see paragraph 3-7).
- Operate lift and positioning cylinders control levers, and check operation of lift and positioning cylinders (see paragraph 2-21).
- Check for leaks.

---

## 4-109. HYDRAULIC LINES REPLACEMENT

---

This Task Covers:

- |  |   |
|--|---|
| <ul style="list-style-type: none"> <li>a. Hydraulic Reservoir Outlet-to-Hydraulic Pump Inlet Hose Assembly Replacement</li> <li>b. Hydraulic Pump Outlet-to-Hydraulic Control Valve Inlet Hose Assembly Replacement</li> <li>c. Hydraulic Control Valve Outlet-to-Hydraulic Reservoir Inlet Hose Assemblies Replacement</li> </ul> | <ul style="list-style-type: none"> <li>d. Hydraulic Control Valve-to-Hydraulic Lift Cylinder Hose Assemblies Replacement</li> <li>e. Hydraulic Control Valve-to-Hydraulic Positioning Cylinder Hose Assemblies Replacement</li> </ul> |
|--|---|
- 

initial Setup:

### Equipment Conditions:

- Dolly set lowered (see paragraph 2-8).
- Engine starter switch set to OFF position (see paragraph 2-20).

### Tools/Test Equipment:

- General mechanic's tool kit (Item 30, Appendix G)

### Materials/Parts:

- Hydraulic fluid (Item 15, Appendix F)
  - Rags (Item 25, Appendix F)
  - Marker tags (Item 28, Appendix F)
    - Masking tape, 2 in. (Item 32, Appendix F)
  - Locknuts
  - Tie-down straps
- 

**WARNING**

- DO NOT disconnect hydraulic lines and fittings while engine is running or before hydraulic system pressure has been released. When engine is running, hydraulic system is under pressure. Dolly set must be fully lowered to the ground and engine must be shut down before lines and fittings are disconnected. A line or fitting disconnected under pressure will explode with great force and cause serious injury or death to personnel.
- Escaping hydraulic fluid under pressure can penetrate the skin, causing serious injury to personnel. Relieve pressure before disconnecting hydraulic lines and fittings. Tighten all connections before applying pressure. Keep hands and body away from pinholes and nozzles which eject hydraulic fluid under high pressure. Use a piece of cardboard or paper to search for leaks. If any hydraulic fluid is injected into the skin, it MUST be surgically removed within a few hours by a doctor familiar with this type of injury or gangrene may result.

**CAUTION**

DO NOT allow dirt or dust to enter hydraulic reservoir. Damage to hydraulic system will result.

### NOTE

- Hydraulic lines should be tagged before removal. Refer to paragraph 4-18 for tagging instructions.
- Hydraulic reservoir, hydraulic pump, hydraulic control valve, and hydraulic cylinders ports should be plugged with masking tape or other suitable means as lines are disconnected or fittings are removed. Refer to paragraph 4-22 for instructions.

---

**4-109. HYDRAULIC LINES REPLACEMENT (Con't).**

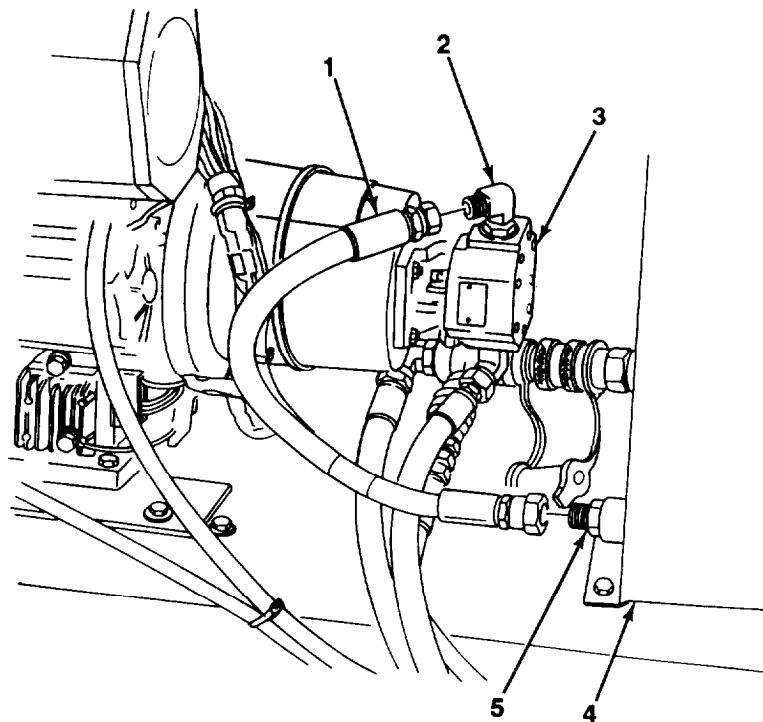
---

NOTE

- A suitable container should be used to catch any draining hydraulic fluid. Ensure that oil spills are properly cleaned.
- During removal, tie-down straps must be removed from hydraulic hose assemblies, electrical cable assemblies, and abrasion sleeve, as required. Hose assemblies inside abrasion sleeve (hose bundle) must also be removed from attachment to muffler cover and angle bracket at hydraulic reservoir (rear doily only), as required. Ensure that new tie-down straps are used during installation. Also ensure that hose assemblies are properly supported, as noted during removal.

**a. HYDRAULIC RESERVOIR OUTLET-TO-HYDRAULIC PUMP INLET HOSE ASSEMBLY REPLACEMENT**

1. Drain hydraulic reservoir (see paragraph 4-111).
2. Disconnect hose assembly (1) from elbow (2) at inlet (top) of hydraulic pump (3).
3. Disconnect hose assembly (1) from straight connector (5) at reservoir (4). Remove hose assembly.
4. Connect hose assembly (1) to straight connector (5).
5. Connect hose assembly (1) to elbow (2).



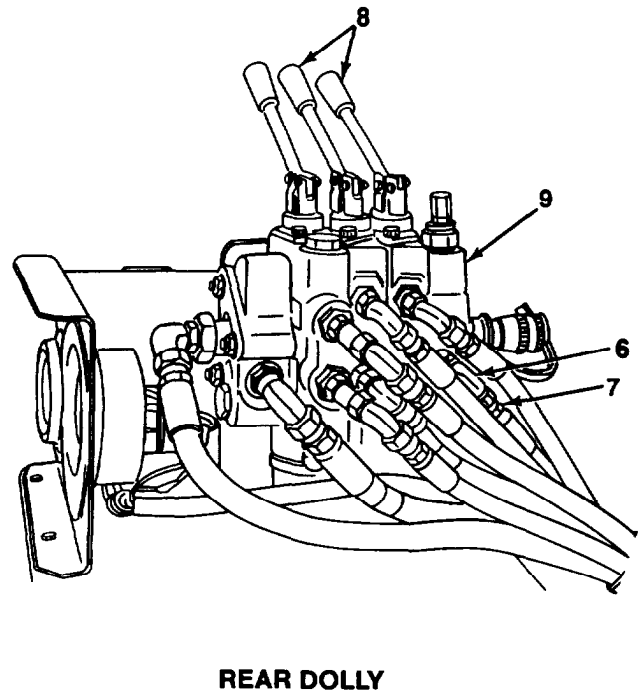
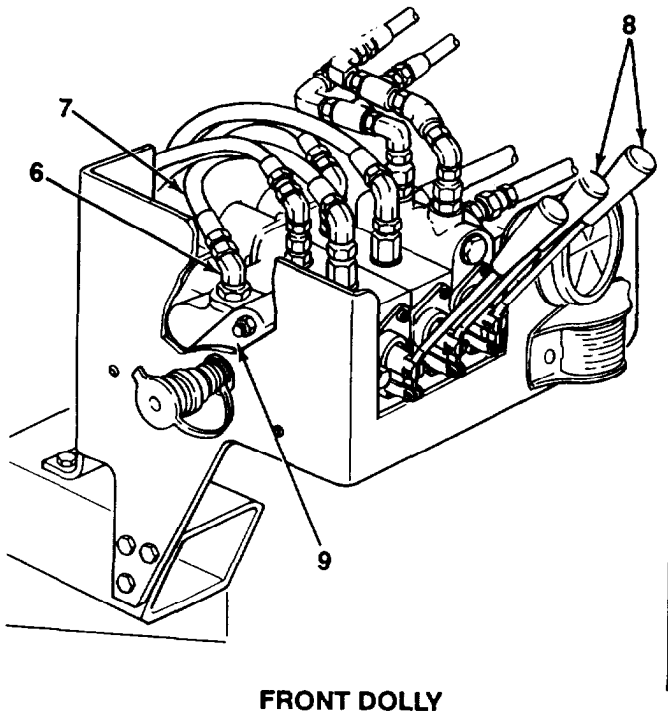
---

**4-109. HYDRAULIC LINES REPLACEMENT (Con't).**

---

**b. HYDRAULIC PUMP OUTLET-TO-HYDRAULIC CONTROL VALVE INLET HOSE ASSEMBLY REPLACEMENT**

1. Drain hydraulic reservoir (see paragraph 4-111).
2. Disconnect hose assembly (7) from elbow (6) at inlet section (9) of hydraulic control valve (8).

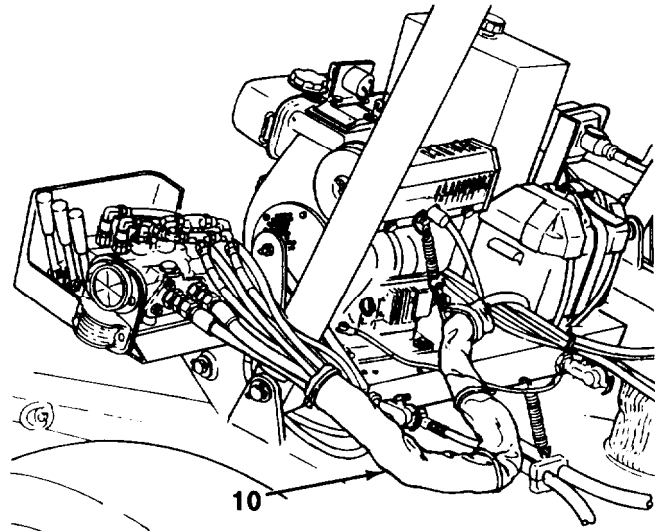


---

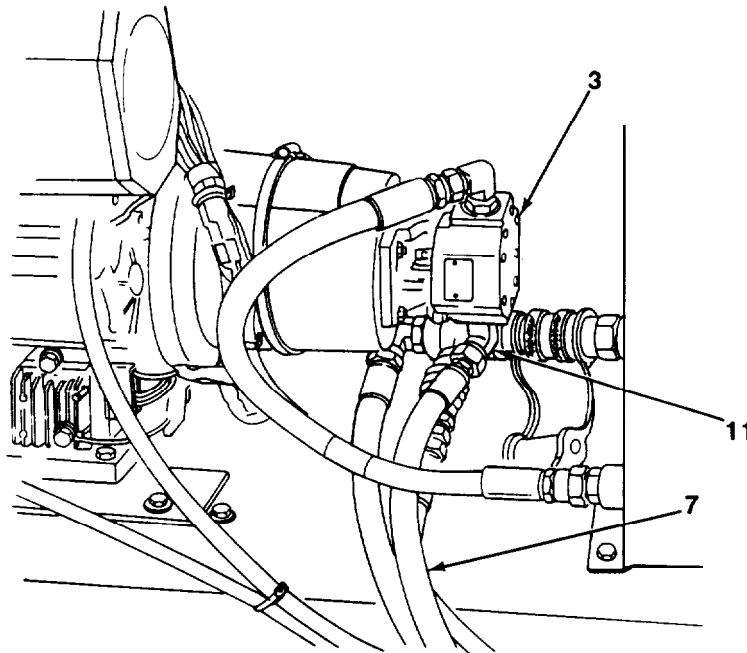
#### 4-109. HYDRAULIC LINES REPLACEMENT (Con't).

---

3. Release hose bundle from supported position. Remove tie-down straps from abrasion sleeve (10). Discard tie-down straps.



4. Disconnect hose assembly (7) from elbow (11) at outlet (bottom) of hydraulic pump (3).
5. Lace replacement hose assembly (7) to hose assembly being removed. Remove hose assembly from inside abrasion sleeve (10) while pulling through replacement hose assembly.
6. Connect hose assembly (7) to elbow (11).

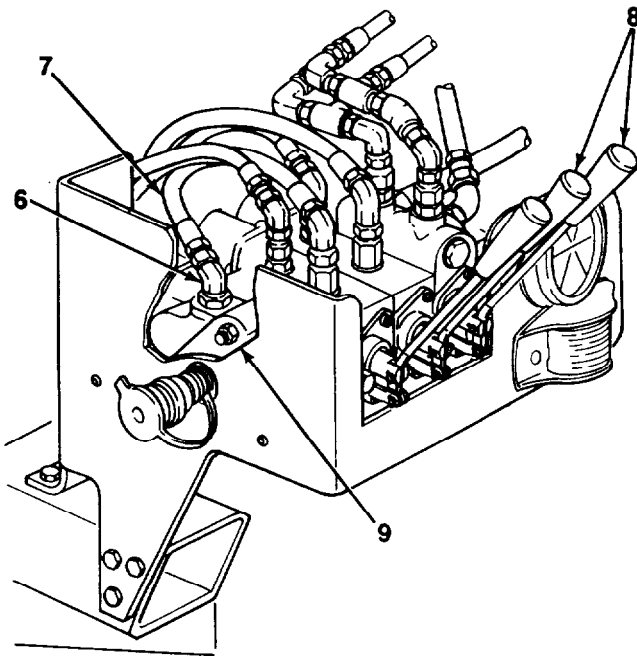
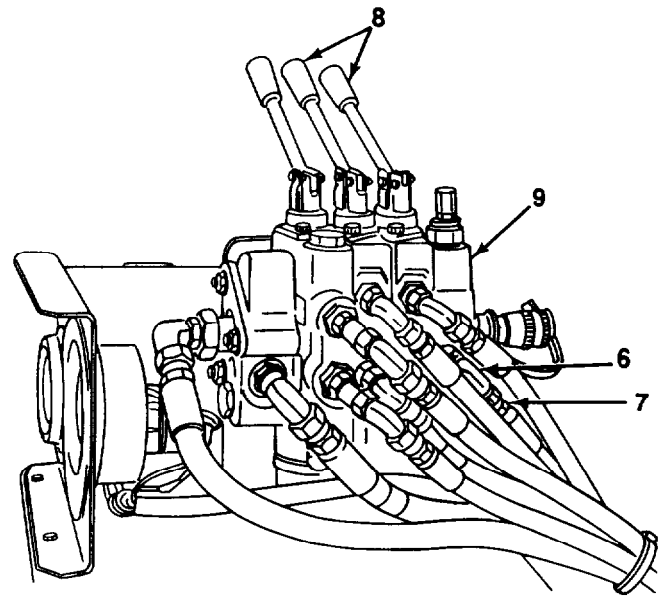


---

**4-109. HYDRAULIC LINES REPLACEMENT (Con't).**

---

7. Connect hose assembly (7) to elbow (6) at inlet section (9) of hydraulic control valve (8).

**FRONT DOLLY****REAR DOLLY**

8. Install new tie-down straps around abrasion sleeve (10). Raise hose bundle and secure in supported position, as noted during removal.

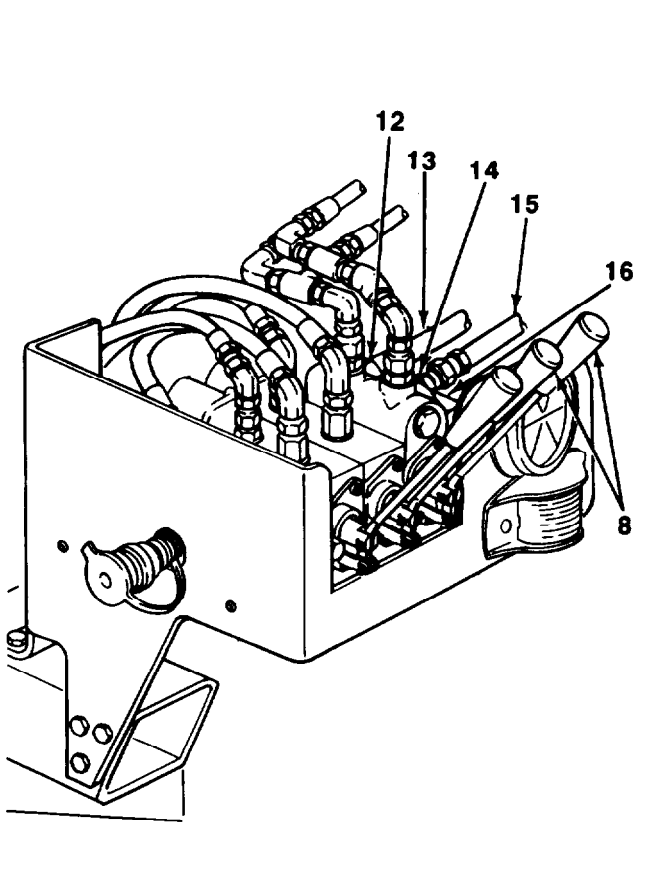
---

## 4-109. HYDRAULIC LINES REPLACEMENT (Con't).

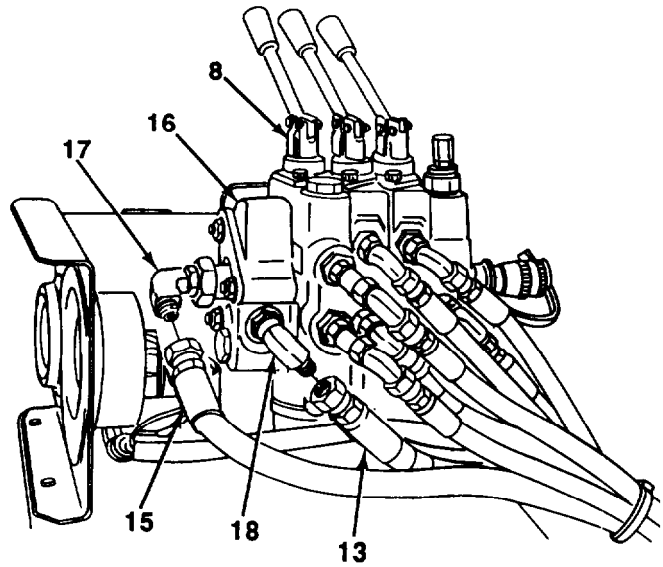
---

**c. HYDRAULIC CONTROL VALVE OUTLET-TO-HYDRAULIC RESERVOIR INLET HOSE ASSEMBLIES REPLACEMENT**

1. Drain hydraulic reservoir (see paragraph 4-111).
2. Disconnect hose assembly (15) from union (14) (front dolly) or elbow (17) (rear dolly) at outlet section (16) of hydraulic control valve (8).



**FRONT DOLLY**



**REAR DOLLY**

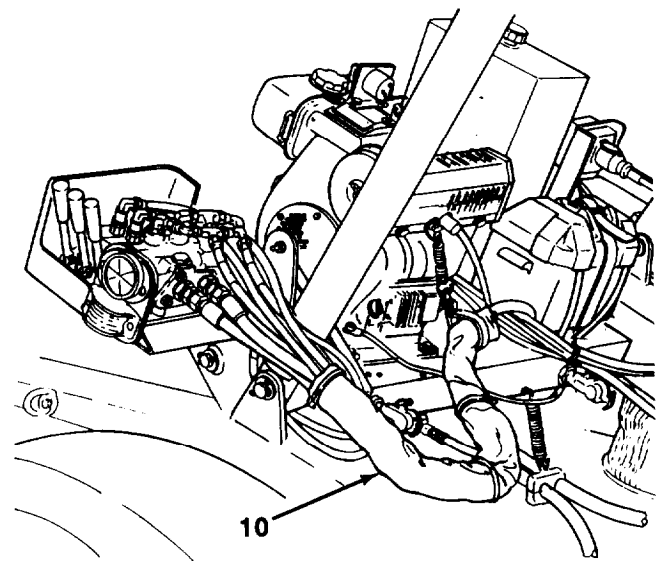
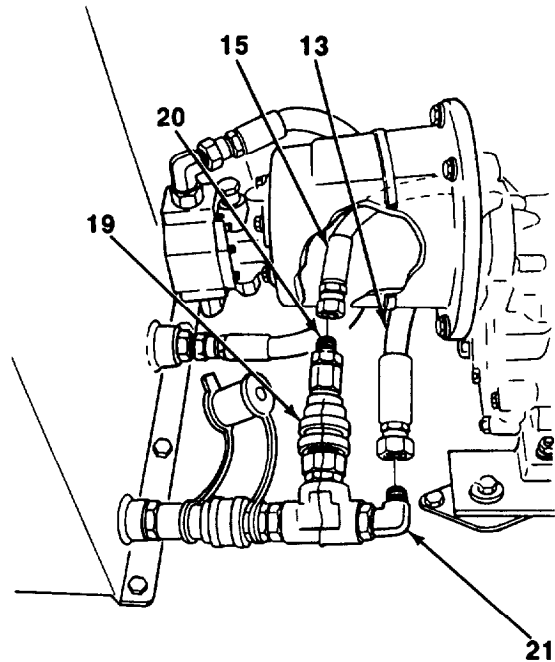


---

**4-109. HYDRAULIC LINES REPLACEMENT (Con't).**


---

3. Disconnect hose assembly (13) from union (12) (front dolly) or swivel nut elbow (18) (rear dolly) at outlet section (16) of hydraulic control valve (8).
4. Release hose bundle from supported position. Remove tie-down straps from abrasion sleeve (10). Discard tie-down straps.
5. Disconnect hose assembly (15) from straight connector (20) at quick disconnect fitting (19).
6. Disconnect hose assembly (13) from elbow (21).
7. Lace replacement hose assemblies (13 and 15) to hose assemblies being removed. Remove hose assemblies from inside abrasion sleeve (10) while pulling through replacement hose assemblies.
8. Connect hose assembly (13) to elbow (21).
9. Connect hose assembly (15) to straight connector (20).
10. Connect hose assembly (13) to union (12) (front dolly) or swivel nut elbow (18) (rear dolly).
11. Connect hose assembly (15) to union (14) (front dolly) or elbow (17) (rear dolly) at outlet section (16) of hydraulic control valve (8).
12. Install new tie-down straps around abrasion sleeve (10). Raise hose bundle and secure in supported position, as noted during removal.

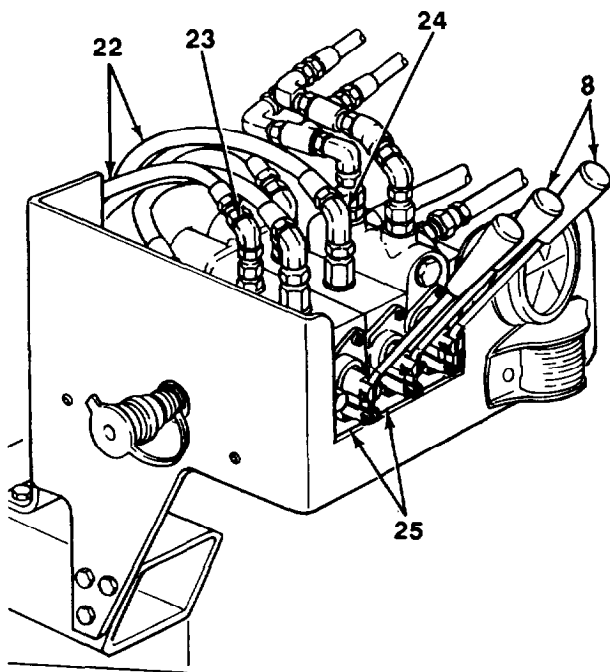


4-109. HYDRAULIC LINES REPLACEMENT (Con't).

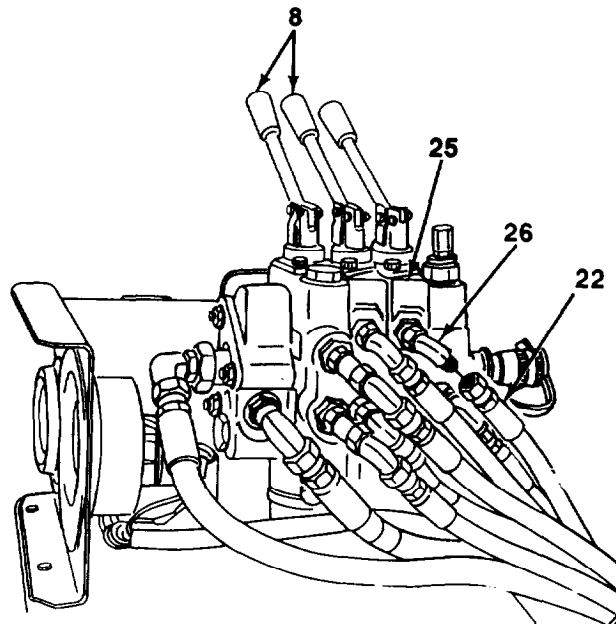
**d. HYDRAULIC CONTROL VALVE-TO-HYDRAULIC LIFT CYLINDER HOSE ASSEMBLIES REPLACEMENT**

NOTE

- Hose assemblies to extend or retract each hydraulic lift cylinder are replaced the same way except as noted. Note position of hose assemblies to aid during Installation.
  - At control valve, hose assemblies to extend hydraulic lift cylinders are connected to bottom ports of lift cylinder work sections; hose assemblies to retract hydraulic lift cylinders are connected to top ports.
  - EXTEND and RETRACT ports at hydraulic lift cylinders are Illustrated.
1. Disconnect hose assembly (22) from swivel nut elbow (23) (front dolly, bottom port) or long elbow (24) (front dolly, top port) or swivel nut elbow (26) (rear dolly) at lift cylinder work section (25) of hydraulic control valve (8).



FRONT DOLLY



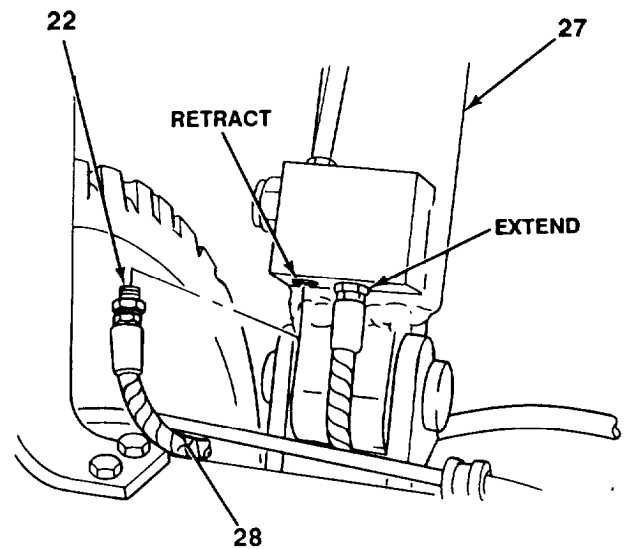
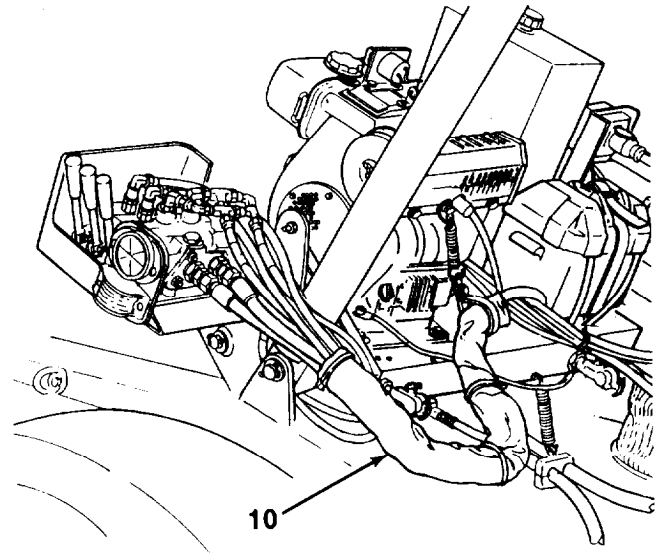
REAR DOLLY

---

**4-109. HYDRAULIC LINES REPLACEMENT (Con't).**

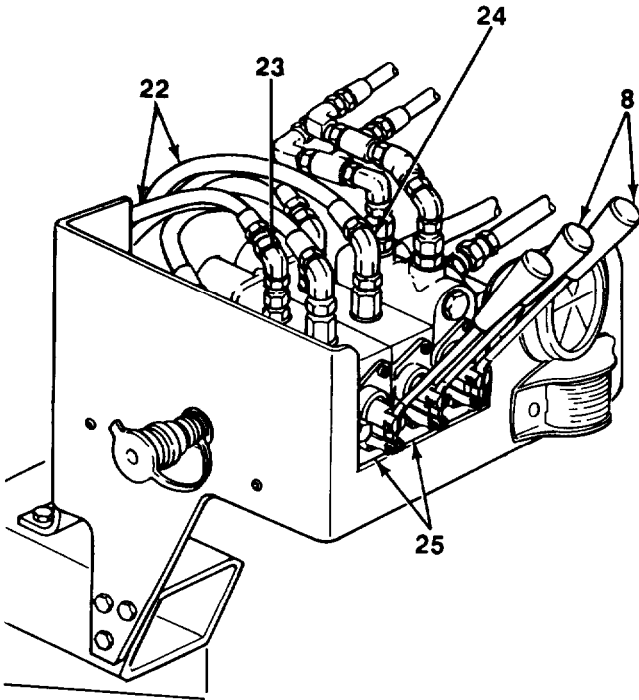

---

2. If removing hose assembly (22) to far (right side) hydraulic lift cylinder, release hose bundle from supported position. Remove tie-down straps from abrasion sleeve (10). Discard tie-down straps.
3. Disconnect hose assembly (22) from hydraulic lift cylinder (27).
4. If removing hose assembly (22) to far (right side) hydraulic lift cylinder (27), lace replacement hose assembly to hose assembly being removed. Remove hose assembly from inside abrasion sleeve (10) while pulling through replacement hose assembly.
5. Remove coil sleeve (28) from hose assembly (22)
6. Install coil sleeve (28) to hose assembly (22), starting 1 in. (2.5 cm) from hydraulic lift cylinder (27) fitting.
7. Connect hose assembly (22) to hydraulic lift cylinder (27).

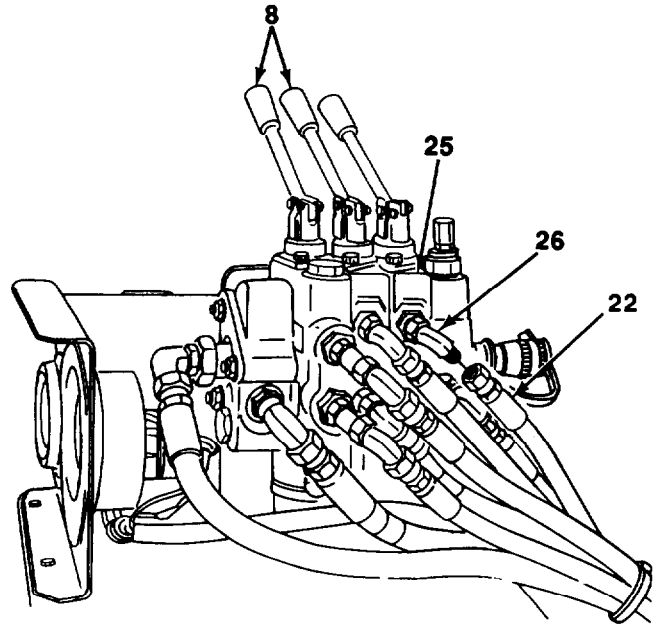


**4-109. HYDRAULIC LINES REPLACEMENT (Con't).**

8. Connect hose assembly (22) to swivel nut elbow (23) (front dolly, bottom port) or long elbow (24) (front dolly, top port) or swivel nut elbow (26) (rear dolly) at lift cylinder work section (25) of hydraulic control valve (8).

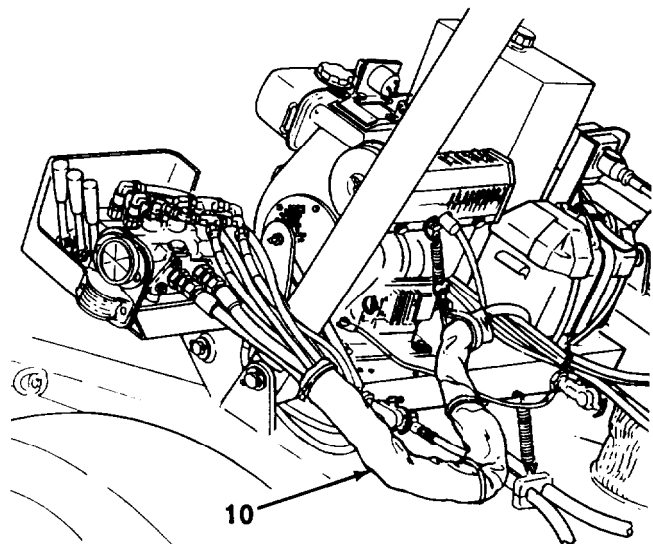


FRONT DOLLY



REAR DOLLY

9. If removed, install new tie-down straps around abrasion sleeve (10). Raise hose bundle and secure in supported position, as noted during removal.



---

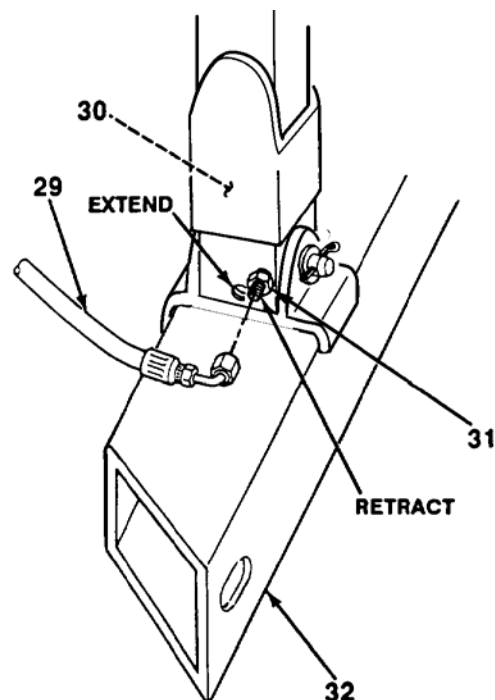
**4-109. HYDRAULIC LINES REPLACEMENT (Con't).**

---

<b>e. HYDRAULIC CONTROL VALVE-TO-HYDRAULIC POSITIONING CYLINDER HOSE ASSEMBLIES REPLACEMENT</b>
---

**NOTE**

- \* Hose assemblies to extend or retract each hydraulic positioning cylinder are replaced the same way except as noted. Note position of hose assemblies to aid during installation.
  - \* At hydraulic control valve, hose assemblies to extend hydraulic positioning cylinders are connected to bottom port of positioning cylinders work section; hose assemblies to retract hydraulic positioning cylinders are connected to top port.
  - \* **EXTEND** and **RETRACT** ports at hydraulic positioning cylinders are illustrated.
  - \* Hose assemblies to near (left side) hydraulic positioning cylinder connect to swivel nut tees at hydraulic control valve.
  - \* Hose assemblies to far (right side) hydraulic positioning cylinder connect to swivel nut elbows at hydraulic control valve.
1. Disconnect hose assembly (29) from straight connector (31) at positioning cylinder (30) inside bottom beam (32).



DS1022-076

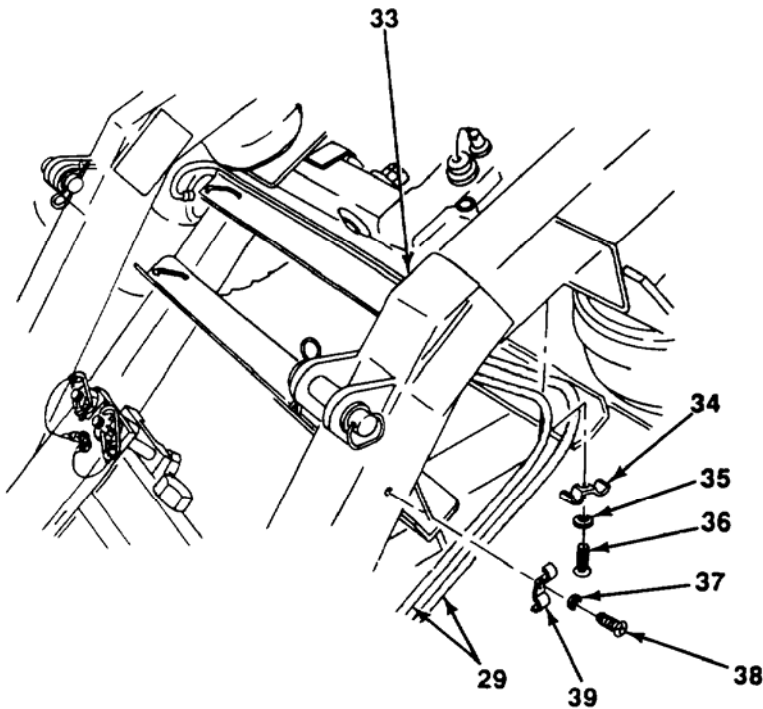
**4-109. HYDRAULIC LINES REPLACEMENT (Con't).**

2. Remove self-tapping screw (38), flatwasher (37), and hose clamp (39). Release two hose assemblies (29) from side of suspension link (33).

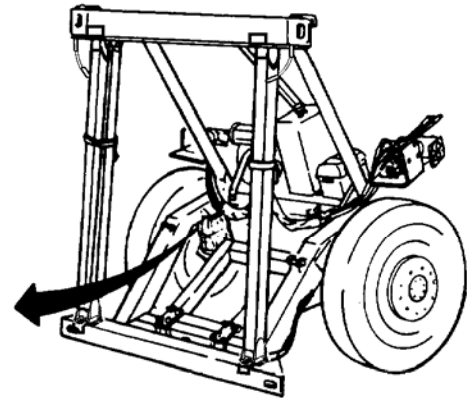
**NOTE**

**Perform steps 3 and 4 only if removing hose assembly to a far (right side) hydraulic positioning cylinder.**

3. Remove self-tapping screw (36), flat washer (35), and hose clamp (34). Release two hose assemblies (29) from underside of suspension link (33).



**RIGHT SIDE**



DS1022-077

4. Release hose bundle from supported position. Remove tie-down straps from abrasion sleeve (10). Discard tie-down straps.

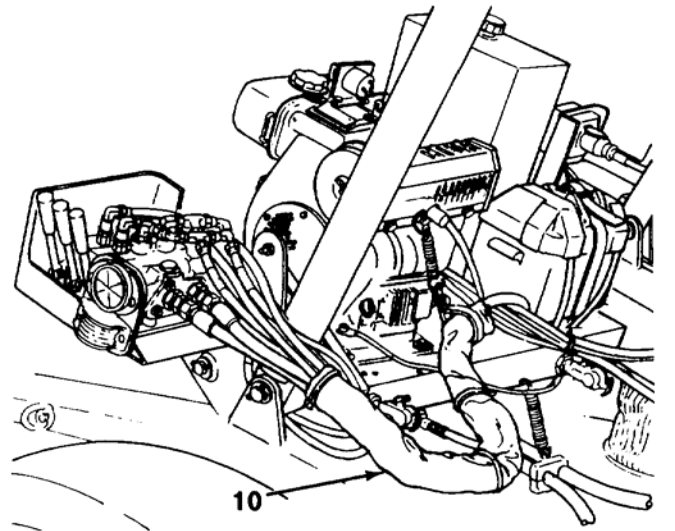
**NOTE**

**Front and rear dolly hose assemblies are connected to hydraulic control valve the same way. Front dolly is illustrated.**

5. Disconnect hose assembly (29) from swivel nut elbow (40) or swivel nut tee (41) at positioning cylinders work section (42) of hydraulic control valve (8).

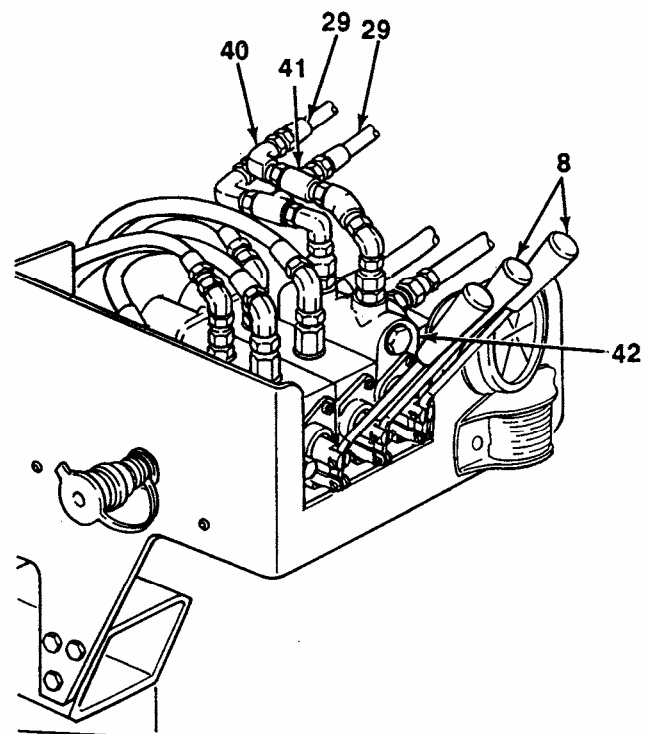
**4-109. HYDRAULIC LINES REPLACEMENT (Con't).**

6. If removing hose assembly (29) to far (right side) hydraulic positioning cylinder, lace replacement hose assembly to hose assembly being removed. Remove hose assembly from abrasion sleeve (10) while pulling through replacement hose assembly.



DS1022-183

7. Connect hose assembly (29) to swivel nut elbow (40) or swivel nut tee (41) at positioning cylinder work section (42) of hydraulic control valve (8).
8. If installing hose assembly (29) to far (right side) hydraulic positioning cylinder, secure two hose assemblies to underside of suspension link (33) with hose clamp (34) flatwasher (35) and self-tapping screw (36).
9. Secure two hose assemblies (29) to side of suspension link (33) with hose clamp (39) flatwasher (37), and self-tapping screw (38).



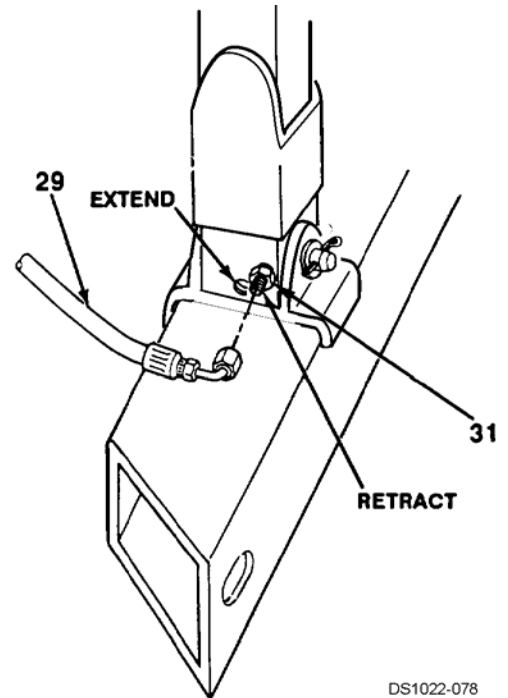
**FRONT DOLLY**

---

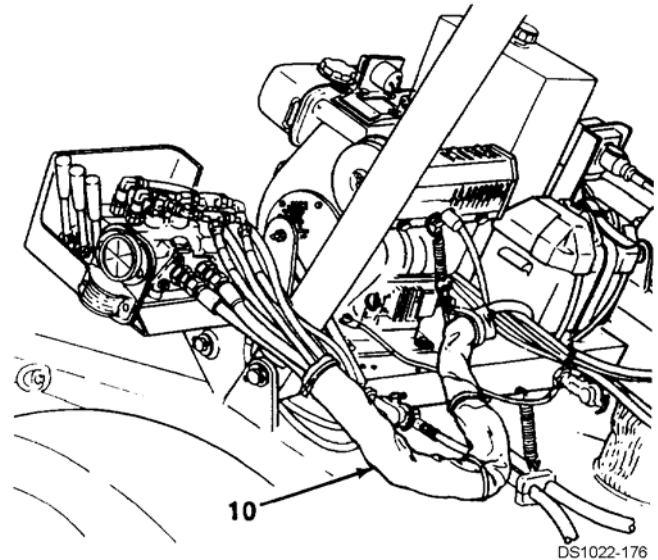
## 4-109. HYDRAULIC LINES REPLACEMENT (Con't).

---

10. Connect hose assembly (29) to straight connector (31).



11. If removed, install new tie-down straps around abrasion sleeve (10). Raise hose bundle and secure in supported position, as noted during removal.



### Follow-on Tasks:

- Check hydraulic fluid level and fill reservoir as required (see paragraph 3-7).
- Operate lift and positioning cylinders control levers, and check operation of lift and positioning cylinders (see paragraph 2-21).
- Check for leaks.



---

## 4-110. HYDRAULIC LIFT CYLINDER REPLACEMENT.

---

*This Task Covers:*

- |                            |                 |
|----------------------------|-----------------|
| a. Removal                 | c. Installation |
| b. Cleaning and Inspection |                 |

---

*Initial Setup:*

**Equipment Conditions:**

- Hydraulic control valve-to-hydraulic lift cylinder hose assemblies removed (see paragraph 4-109).

**Materials/Parts:**

- Rags (Item 25, Appendix F)
- Two cotter pins
- Two lubricating fittings

**Tools/Test Equipment:**

- General mechanic's tool kit (item 30, Appendix G)
- Suitable lifting device

**Personnel Required:** Three

---

**WARNING**

- Use extreme caution when handling heavy parts. Lifting device is required when parts weigh over 50 lb (23 kg) for a single person lift, over 100 lb (45 kg) for a two person lift, and over 150 lb (68 kg) for a three or more person lift. Keep clear of heavy parts supported only by lifting device. Failure to follow this warning may cause serious injury or death to personnel.
- DO NOT attempt to replace both lift cylinders at the same time unless dolly halves are attached to each other or top beam is supported by a suitable lifting device. If top beam is not supported, it will fall to the ground. Failure to follow this warning will cause serious injury or death to personnel.

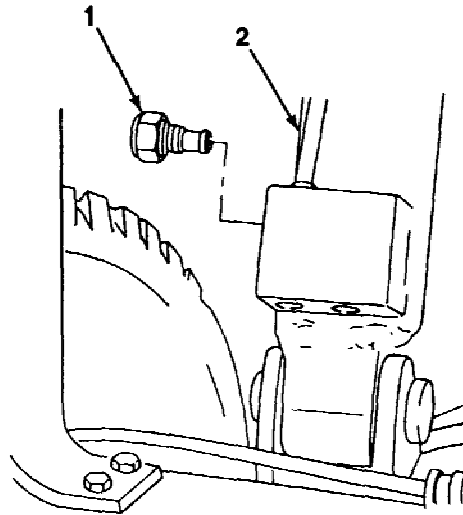
**NOTE**

Standard and side lift lift cylinders are replaced the same way. Standard lift cylinder is shown.

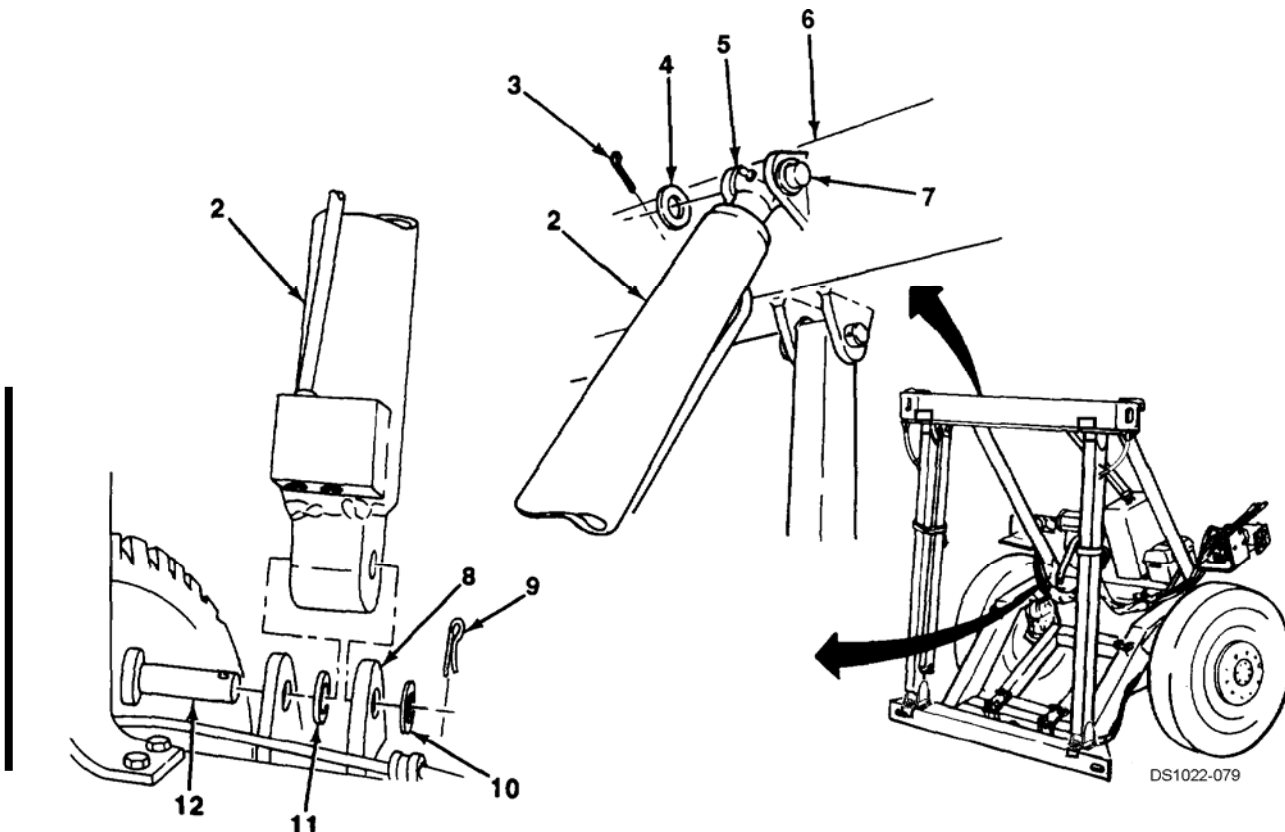
**4-110. HYDRAULIC LIFT CYLINDER REPLACEMENT (Con't).**

**a. REMOVAL**

1. Remove check valve (1) from hydraulic lift cylinder (2), if damaged.
2. Support lift cylinder (2) with a suitable lifting device.



3. Remove cotter pin (3), flatwasher (4), and clevis pin (7) from hydraulic lift cylinder (2) and top beam (6). Discard cotter pin.



---

**4-110. HYDRAULIC LIFT CYLINDER REPLACEMENT (Con't).**

---

**NOTE**

· Note position of spacer (11) to aid during installation.

· There is no spacer on right side of front dolly.

4. Remove cotter pin (9) flatwasher (10), clevis pin (12), spacer (11), and hydraulic lift cylinder (2) from suspension link (8). Discard cotter pin.
5. Remove hydraulic lift cylinder (2) and place on a clean work surface.
6. Remove lifting device from hydraulic lift cylinder (2).
7. Remove two lubrication fittings (5) from hydraulic lift cylinder (2). Discard lubrication fittings.

**b. CLEANING AND INSPECTION**

1. Clean all removed components with a clean rag.
2. Inspect all components for cracks, breaks, bends, corrosion, or damaged threads. Replace damaged components.

**c. INSTALLATION**

1. Install two new lubrication fittings (5) on hydraulic lift cylinder (2).
2. Support hydraulic lift cylinder (2) with a suitable lifting device.

**NOTE**

There Is no spacer on right side of front dolly.

3. Install hydraulic lift cylinder (2) on suspension link (8) with spacer (11), clevis pin (12), flatwasher (10), and new cotter pin (9).

**NOTE**

Ensure that grease fitting at rod end of hydraulic lift cylinder Is facing up.

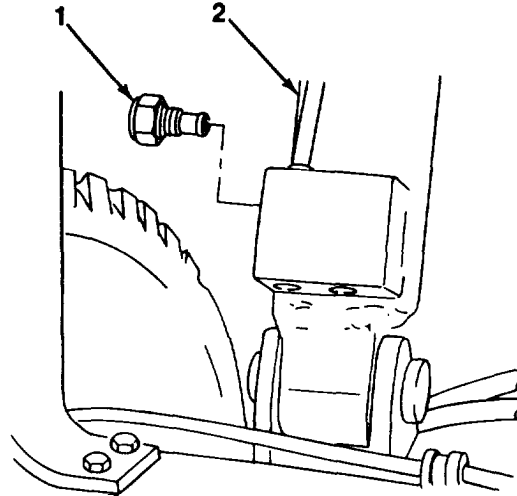
4. Install hydraulic lift cylinder (2) on top beam (6) with clevis pin (7) flatwasher (4) and new cotter pin (3).
5. Remove lifting device from hydraulic lift cylinder (2).

---

#### 4-110. HYDRAULIC LIFT CYLINDER REPLACEMENT (Con't).

---

6. Install check valve (1) on hydraulic lift cylinder (2),  
If removed.



#### Follow-on Tasks:

- 1 Install hydraulic control valve-to-hydraulic lift cylinder hose assemblies (see paragraph 4-109).
- 1 Lubricate lift cylinder (see Lubrication Instructions, Chapter 3, Section 1).
- 1 Bleed hydraulic system (see paragraph 4-112 or 4-113).
- 1 Check for leaks.

---

**4-111. HYDRAULIC RESERVOIR AND REDUNDANT POWER FITTINGS REPLACEMENT.**


---

*This Task Covers:*

- |             |                            |
|-------------|----------------------------|
| a. Draining | c. Cleaning and Inspection |
| b. Removal  | d. Installation            |
- 

*Initial Setup:*

**Equipment Conditions:**

- Dolly set lowered (see paragraph 2-8).
- Engine starter switch set to OFF position (see paragraph 2-20).
- Cold start kit removed, if equipped (see paragraph 4-138.1).

**Tools/Test Equipment:**

- General mechanic's tool kit (Item 30, Appendix G)

**Materials/Parts:**

- Hydraulic fluid (Item 15, Appendix F)
  - Rags (Item 25, Appendix F)
  - Marker tags (Item 28, Appendix F)
  - Masking tape, 2 in. (Item 32, Appendix F)
  - One lockwire
  - Six locknuts
  - Nine preformed packings
- 

**WARNING**

- **DO NOT** disconnect hydraulic lines and fittings while engine is running or before hydraulic system pressure has been released. When engine is running, hydraulic system is under pressure. Dolly set must be fully lowered to the ground and engine must be shut down before lines and fittings are disconnected. A line or fitting disconnected under pressure will explode with great force and cause serious injury or death to personnel.
- Escaping hydraulic fluid under pressure can penetrate the skin, causing serious injury to personnel. Relieve pressure before disconnecting hydraulic lines and fittings. Tighten all connections before applying pressure. Keep hands and body away from pinholes and nozzles which eject hydraulic fluid under high pressure. Use a piece of cardboard or paper to search for leaks. If any hydraulic fluid is injected into the skin, it **MUST** be surgically removed within a few hours by a doctor familiar with this type of injury or gangrene may result.

**CAUTION**

**DO NOT** allow dirt or dust to enter hydraulic reservoir. Damage to hydraulic system will result.

**NOTE**

- Hydraulic lines should be tagged before removal. Refer to paragraph 4-18 for tagging instructions.
- Hydraulic reservoir, hydraulic pump, hydraulic control valve, and hydraulic cylinders ports should be plugged with masking tape or other suitable means as lines are disconnected or fittings are removed. Refer to paragraph 4-22 for instructions.
- A suitable container should be used to catch any draining hydraulic fluid. Ensure that all spills are properly cleaned.

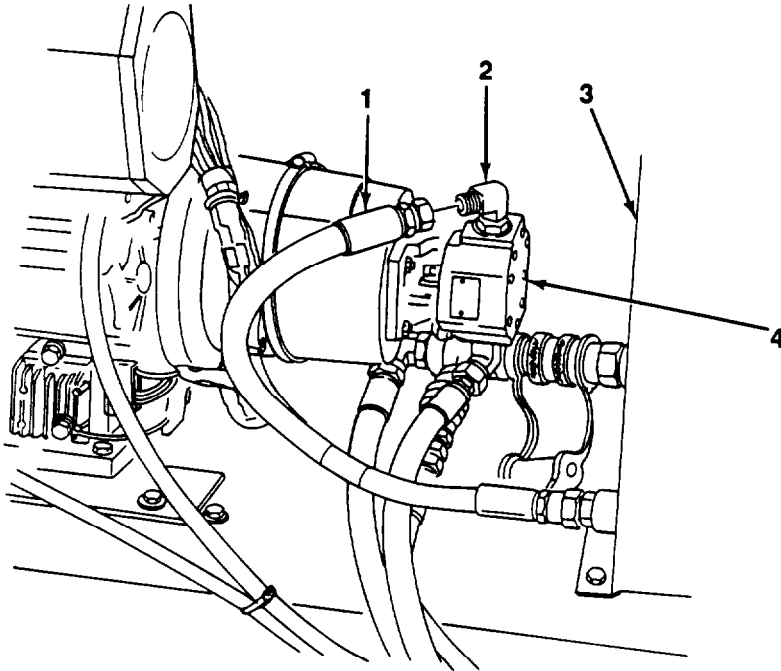
---

4-111. HYDRAULIC RESERVOIR AND REDUNDANT POWER FITTINGS REPLACEMENT  
(Con't).

---

**a. DRAINING**

1. Disconnect hose assembly (1) from elbow (2) at inlet (top) of hydraulic pump (4). Drain hydraulic fluid into a suitable container.
2. If filling hydraulic reservoir (3), connect hose assembly (1) to elbow (2).



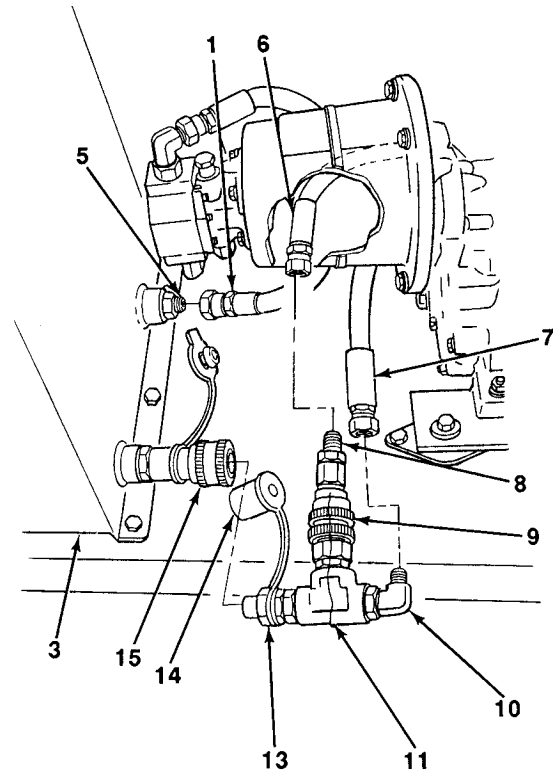
---

**4-111. HYDRAULIC RESERVOIR AND REDUNDANT POWER FITTINGS REPLACEMENT (Con't).**

---

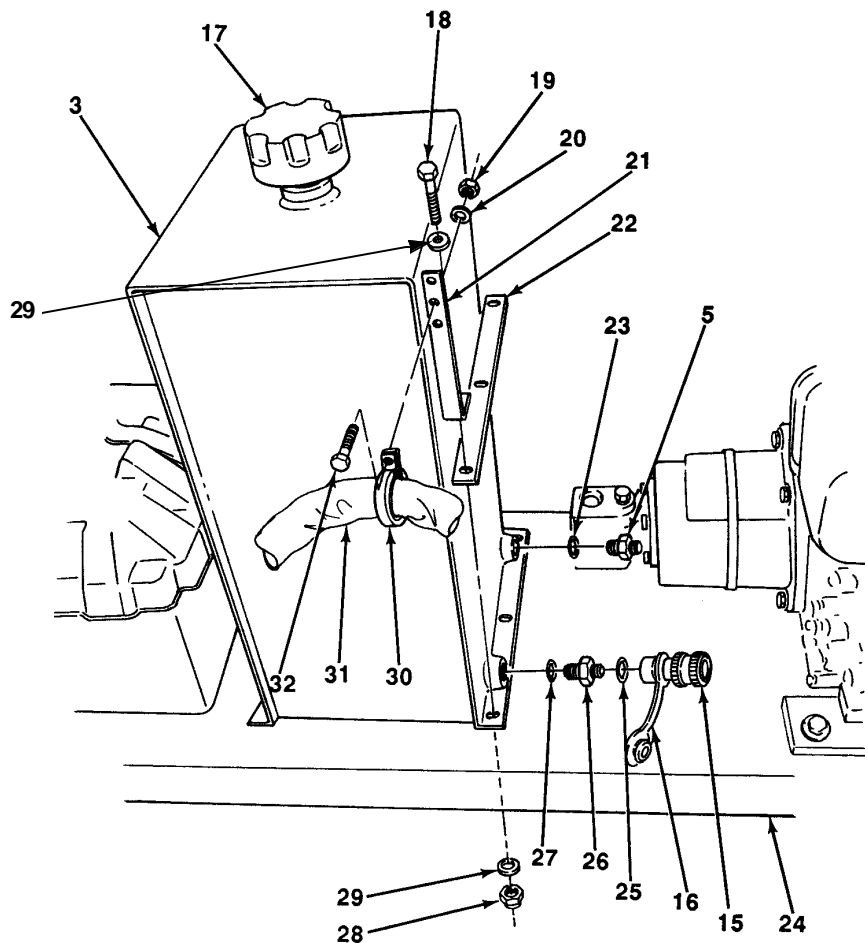
**b. REMOVAL**

1. Drain hydraulic reservoir (3) (see subparagraph a).
2. Disconnect two hose assemblies (6 and 7) from straight connector (8) and elbow (10).
3. Disconnect hose assembly (1) from straight connector (5).
4. Cut lockwire (11) from fittings. Discard lockwire.
5. Remove dustcap (16) from dust plug (14). Disconnect quick disconnect nipple (13) with fittings from quick disconnect coupler (15).



## 4-111. HYDRAULIC RESERVOIR AND REDUNDANT POWER FITTINGS REPLACEMENT (Con't).

6. On rear dolly only, remove locknut (19), flatwasher (20), screw (32), and clamp (30) with hose bundle (31) from angle bracket (21). Discard locknut.
7. Remove six locknuts (28), 12 flatwashers (29), capscrews (18), angle bracket (21) (rear dolly only), two mounting plates (22), and hydraulic reservoir (3) with fittings from pivoting tray (24). Discard locknuts.
8. Remove cap (17) from hydraulic reservoir (3).
9. Remove straight connector (5) and preformed packing (23) from hydraulic reservoir (3). Discard preformed packing.
10. Remove quick disconnect coupler (15), preformed packing (25), union (26), and preformed packing (27) from hydraulic reservoir (3). Remove dust cap (16) from quick disconnect coupler. Discard preformed packings.





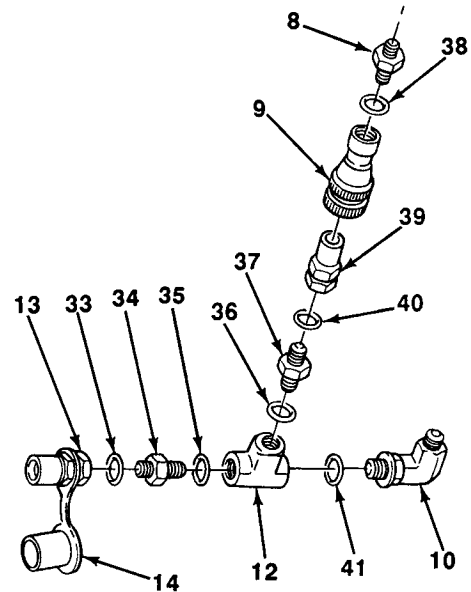
## 4-111. HYDRAULIC RESERVOIR AND REDUNDANT POWER FITTINGS REPLACEMENT (Con't).

11. Remove elbow (10) and preformed packing (41) from tee (12). Discard preformed packing.
12. Remove straight connector (8), preformed packing (38), quick disconnect coupler (9), quick disconnect nipple (39), preformed packing (40), union (37), and preformed packing (36) from tee (12). Discard preformed packings.
13. Remove quick disconnect nipple (13), preformed packing (33), union (34), and preformed packing (35) from tee (12). Remove dust plug (14) from quick disconnect nipple. Discard preformed packings.

### c. CLEANING AND INSPECTION

1. Clean all removed components with a clean rag.
2. Inspect all components for cracks, breaks, bends, corrosion, or damaged threads. Replace damaged components.

### d. INSTALLATION



### NOTE

**Preformed packings should be lightly coated with hydraulic fluid before installation.**

1. Install dust plug (14) on quick disconnect nipple (13). Install new preformed packing (35), union (34), new preformed packing (33), and quick disconnect nipple on tee (12).
2. Install new preformed packing (36), union (37), new preformed packing (40), quick disconnect nipple (39), quick disconnect coupler (9), new preformed packing (38), and straight connector (8) on tee (12).
3. Install new preformed packing (41) and elbow (10) on tee (12).
4. Install dust cap (16) on quick disconnect coupler (15). Install new preformed packing (27), union (26), new preformed packing (25), and quick disconnect coupler to hydraulic reservoir (3).
5. Install new preformed packing (23) and straight connector (5) on hydraulic reservoir (3).
6. Install cap (17) on hydraulic reservoir (3).

### NOTE

**Largest capscrew is used to mount angle bracket (rear dolly only).**

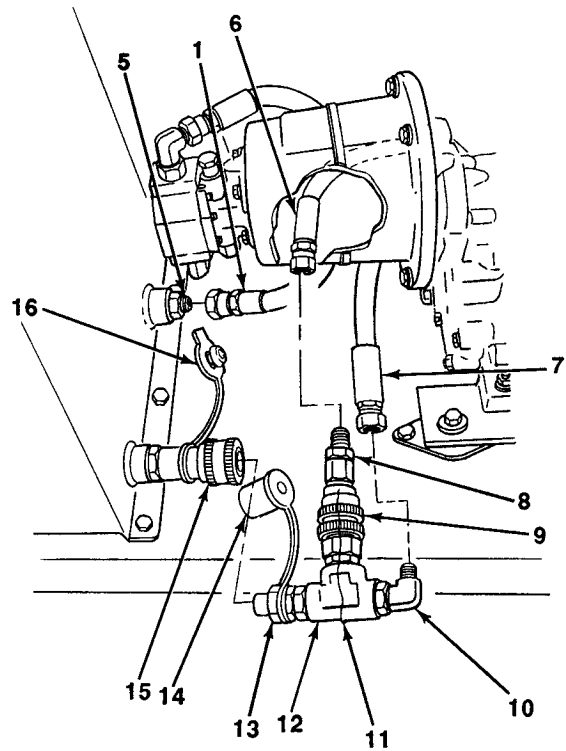
7. Install hydraulic reservoir (3) with fittings, two mounting plates (22), and angle bracket (21) (rear dolly only) on pivoting tray (24) with six capscrews (18), 12 flatwashers (29), and new locknuts (28).
8. On rear dolly only, secure clamp (30) with hose bundle (31) through middle hole of angle bracket (21) with screw (32), flatwasher (20), and new locknut (19).

---

## 4-111. HYDRAULIC RESERVOIR AND REDUNDANT POWER FITTINGS REPLACEMENT (Con't).

---

9. Connect quick disconnect nipple (13) with fittings to quick disconnect coupler (15). Install dust cap (16) on dust plug (14).
10. Wrap new lockwire (11) around quick disconnect coupler (15), tee (12), and quick disconnect coupler (9).
11. Connect hose assembly (1) to straight connector (5).
12. Connect two hose assemblies (6 and 7) to straight connector (8) and elbow (10).

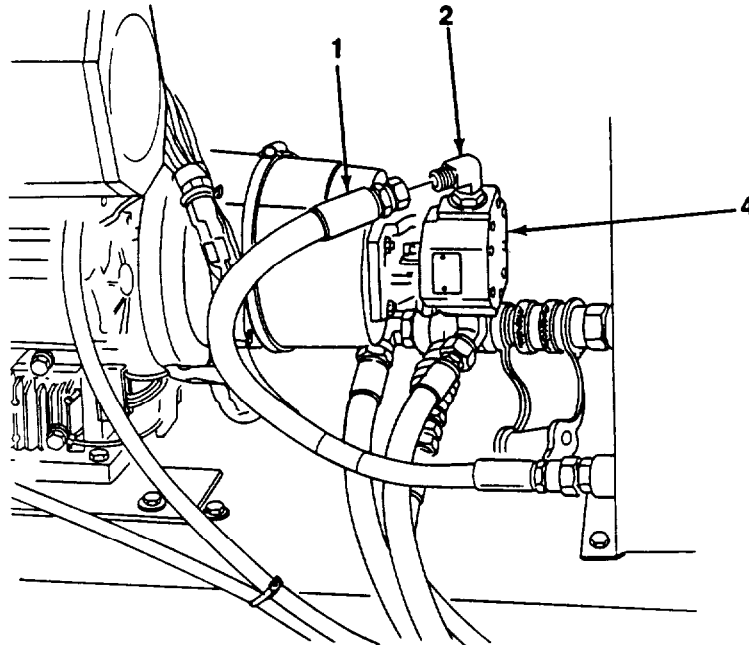


---

## 4-111. HYDRAULIC RESERVOIR AND REDUNDANT POWER FITTINGS REPLACEMENT (Con't).

---

1. Connect hose assembly (1) to elbow (2) at inlet (top) of hydraulic pump (4).



### Follow-on Tasks:

- Fill hydraulic reservoir with hydraulic fluid (see paragraph 3-7).
- Check for leaks.
- If removed, install cold start kit (see paragraph 4-138.1).

---

## 4-112. HYDRAULIC SYSTEM BLEEDING.

---

*This Task Covers:* Bleeding

---

*Initial Setup:*

### Equipment Conditions:

- Front and rear dollies lowered and detached (M1022A1 without side lift kit) (see paragraph 2-8).
- Front and rear dollies lowered and attached (M1022A1 with side lift kit) (see paragraph 2-8).

### Materials/Parts:

- Hydraulic fluid (Item 15, Appendix F)
- Rags (Item 25, Appendix F)

### Tools/Test Equipment:

- Suitable lifting device, 5000 lb capacity minimum
- 

**WARNING**

Top beams of front and rear dollies must be secured with a suitable lifting device throughout entire bleeding procedure if bleeding hydraulic system of a dolly set with side lift kit when ONLY side lift positioning cylinders were replaced. Top and bottom beams must also be kept vertical. Until bleeding is complete, air in the hydraulic system may cause erratic movement when extending and retracting hydraulic cylinders. Failure to support top beams and to keep top and bottom beams vertical may cause an accident resulting in serious injury or death to personnel.

**CAUTION**

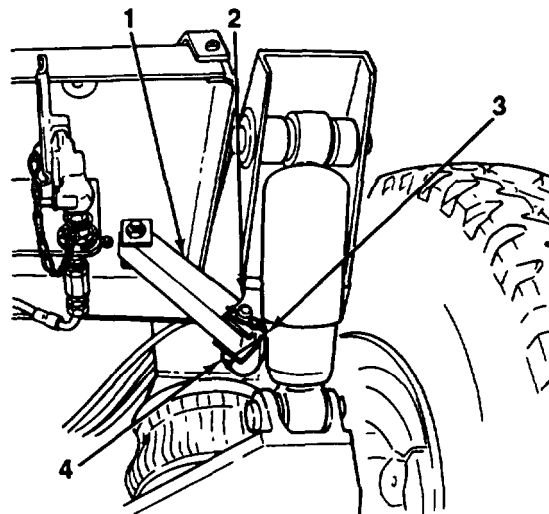
DO NOT allow dirt or dust to enter hydraulic reservoir. Damage to hydraulic system will result.

### NOTE

This procedure is used to bleed the hydraulic system of a dolly half without side lift kit OR a dolly set with side lift kit when ONLY side lift positioning cylinders were replaced.

**BLEEDING**

1. Remove safety pin (3) and hitch pin (4) and unlock pivoting tray lockout brace (1) from lower bracket (2)



---

**4-112. HYDRAULIC SYSTEM BLEEDING (Con't).**


---

**NOTE**

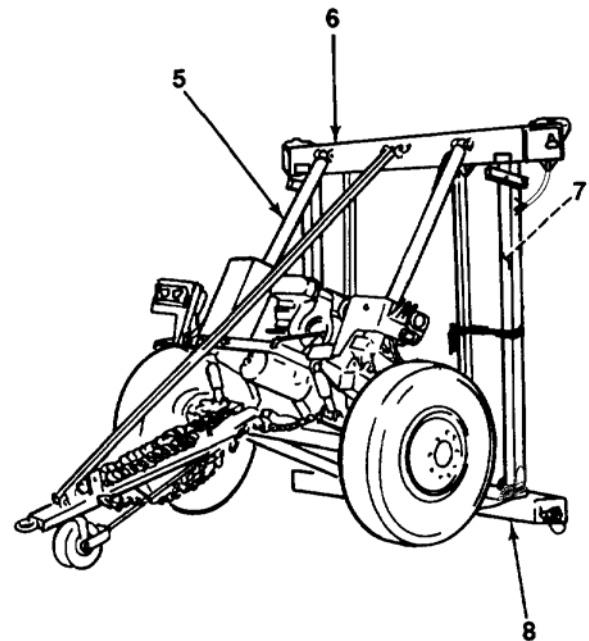
If bleeding hydraulic system of a dolly set with side lift kit, when **ONLY** side lift positioning cylinders were replaced, top beams must be supported by a suitable lifting device capable of raising 16 ft (4.9 m) above the floor. A sling with a minimum capacity of 5000 lb (2270 kg) must be used.

2. Support top beam (6) with a lifting device as required.
3. Start engine (see paragraph 2-20).
4. Fill hydraulic reservoir (see paragraph 3-7).

**NOTE**

**During extension, maintain slack in hoist sling as top beam is raised.**

5. Operate hydraulic control valve to extend lift cylinders (5) and positioning cylinders (7) in turn (see paragraph 2-21). Keep top and bottom beams (6 and 8) vertical as cylinders are extended.



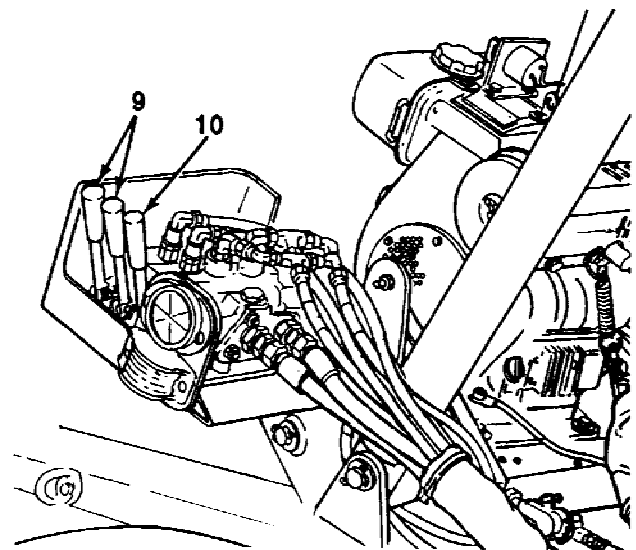
DS1022-080

6. When full extension is reached, hold lift cylinder levers (9) and positioning cylinders lever (10) in extend position for 30 seconds.

**NOTE**

**During retraction, maintain slack in hoist sling as top beam is lowered.**

7. Operate hydraulic control valve to retract lift cylinders (5) and positioning cylinders (7) in turn (see paragraph 2-21). Keep top and bottom beams (6 and 8) vertical as cylinders are retracted.
8. When full retraction is reached, hold lift cylinder levers (9) and positioning cylinders lever (10) in retract position for 30 seconds.

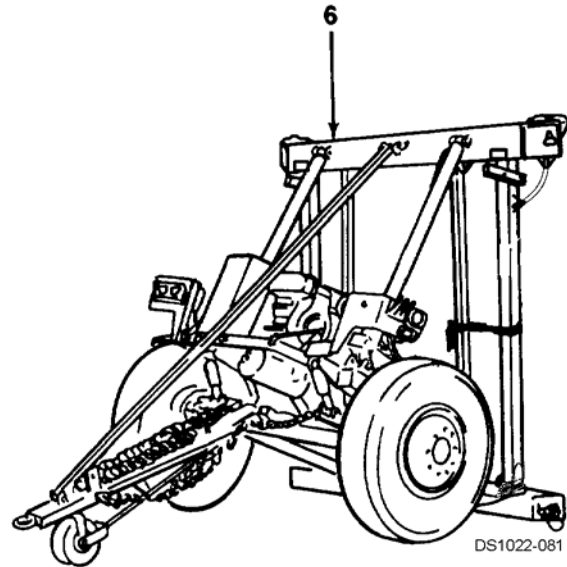


---

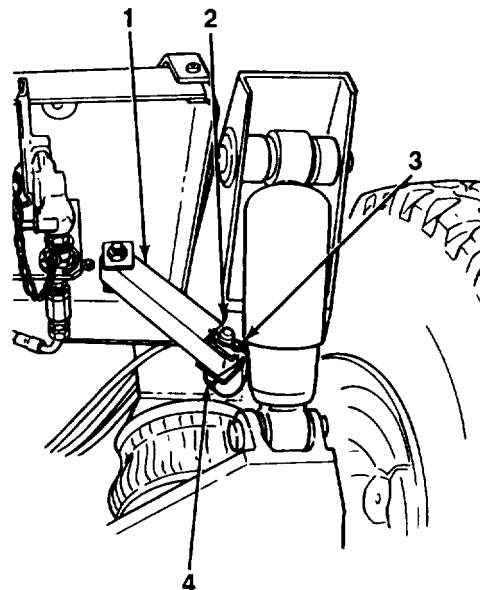
#### 4-112. HYDRAULIC SYSTEM BLEEDING (Con't).

---

9. Shut down engine (see paragraph 2-20).
10. Check hydraulic fluid level and fill as required (see paragraph 3-7).
11. Repeat steps 5 through 8 two more times or until operation of hydraulic system is smooth.
12. Remove support from top beam (6) as required.



13. Install hitch pin (4) and safety pin (3) and lock pivoting tray lockout brace (1) on lower bracket (2).



---

**4-113. HYDRAULIC SYSTEM BLEEDING (M1022A1 WITH SIDE LIFT KIT).**

---

*This Task Covers:* Bleeding

---

*Initial Setup:*

**Equipment Conditions:**

- Front and rear dollies lowered and attached (see paragraph 2-8).
- Steering locking pin installed in steering link.
- Air bags Inflated to riding height (see paragraph 2-22).
- Parking brake lever set to OFF position (see paragraph 2-2).

**Tools/Test Equipment:**

- General mechanic's tool kit (item 30, Appendix G)
- Pipe bushing (two) (Item 2, Appendix G)
- Pressure gage (two) (item 11, Appendix G)
- Steplader (item 26, Appendix G)
- Torque wrench, 0-200 lb.-ft. (Item 41, Appendix G)
- Suitable lifting device, 5000 lb. capacity minimum

**Materials/Parts:**

- Hydraulic fluid (Item 15, Appendix F)
- Rags (Item 25, Appendix F)
- Nonmetallic tubing [two lengths of 20 ft (6.1 m)] (Item 33, Appendix F)
- Four preformed packings

**Personnel Required:** Four

**WARNING**

Top beams of front and rear dollies must be secured with a suitable lifting device throughout entire bleeding procedure. Top and bottom beams must be kept vertical. Until bleeding is complete, air in the hydraulic system may cause erratic movement when extending and retracting hydraulic cylinders. Failure to support top beams and to keep top and bottom beams vertical may cause an accident resulting in serious injury or death to personnel.

**CAUTION**

**DO NOT** allow dirt or dust to enter hydraulic system. Damage to hydraulic system will result.

**NOTE**

- This procedure is used to bleed a dolly set hydraulic system after initial installation of a side lift kit. This procedure is also used after replacement of a single (or both) side lift kit lift cylinder(s).
- After replacement of a single (or both) side lift kit positioning cylinder(s), follow the bleeding procedures in paragraph 4-112.

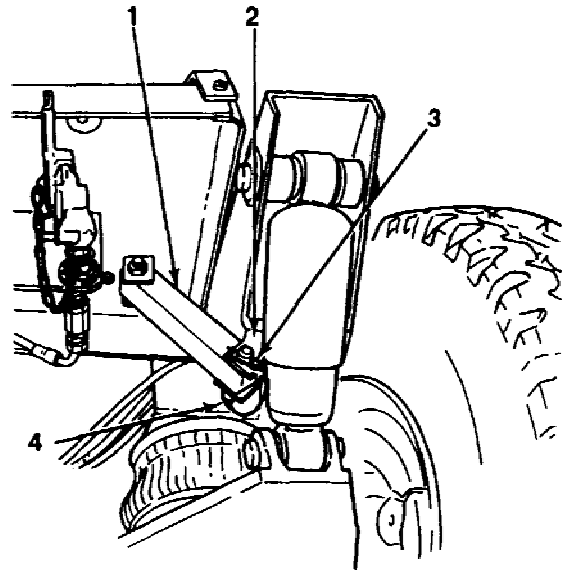
---

**4-113. HYDRAULIC SYSTEM BLEEDING (M1022A1 WITH SIDE LIFT KIT) (Cont).**

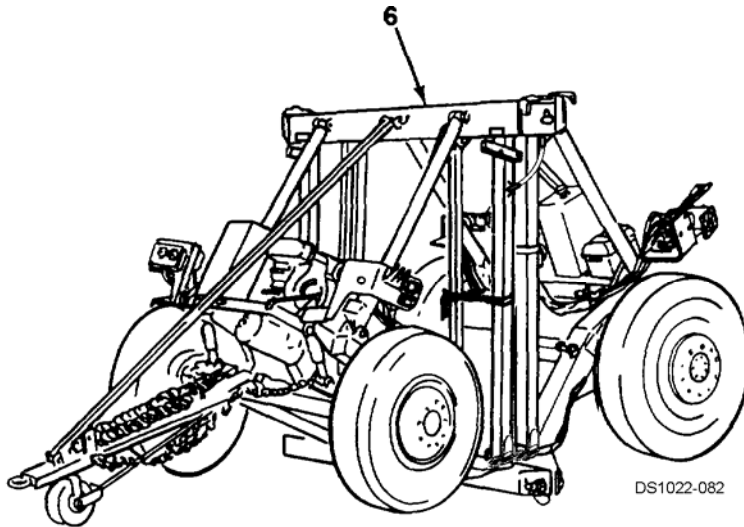
---

**BLEEDING**

1. At front and rear, remove hitch pin (4) and safety pin (3) and unlock pivoting tray lockout brace (1) from lower bracket (2).



2. Support top beams (6) with a lifting device capable of raising 16 ft (4.9 m) above the floor. Use a sling with a minimum capacity of 5000 lb (2270 kg).



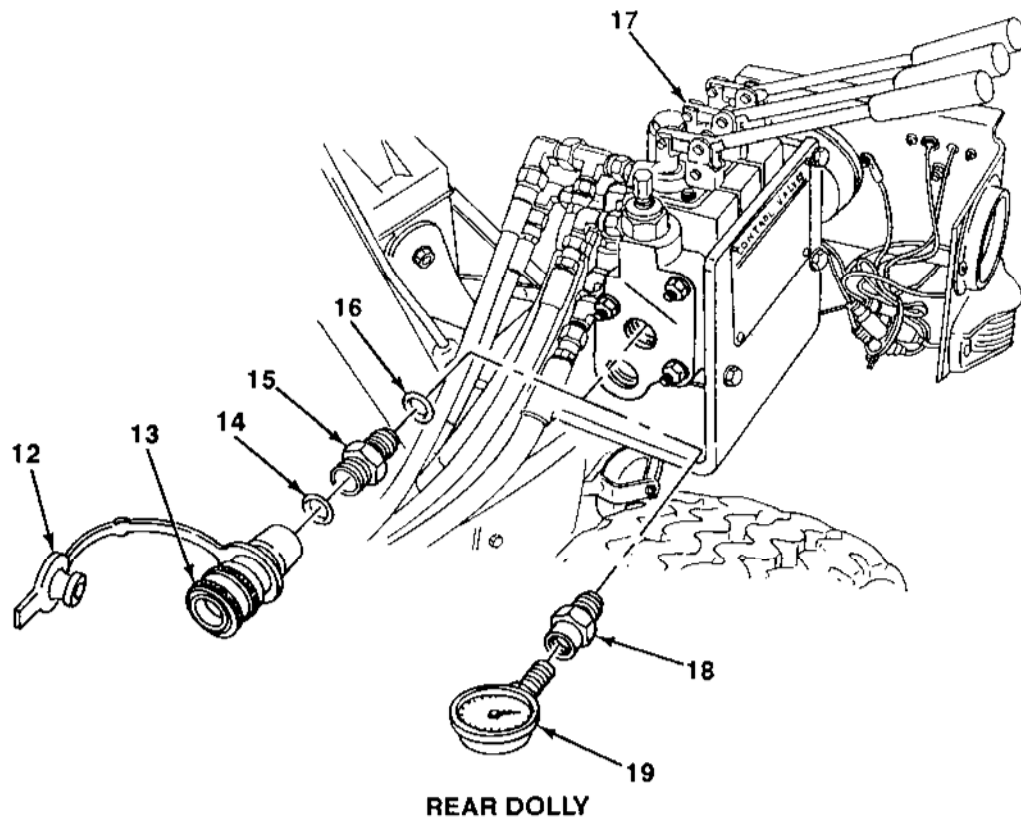


---

**4-113. HYDRAULIC SYSTEM BLEEDING (M1022A1 WITH SIDE LIFT KIT) (Cont).**

---

3. Remove dust cap (12) from redundant power quick disconnect coupler (13). Remove redundant power quick disconnect coupler, preformed packing (14), dust cap, union (front dolly) or straight adapter (15) (rear dolly), and preformed packing (16) from inlet section of each hydraulic control valve (17). Discard preformed packings.
4. Install pipe bushing (18) and pressure gage (19) to inlet section of each control valve (17).
5. At front and rear, start engine (see paragraph 2-20).
6. Fill hydraulic reservoirs to top line on dipstick (see paragraph 3-7).



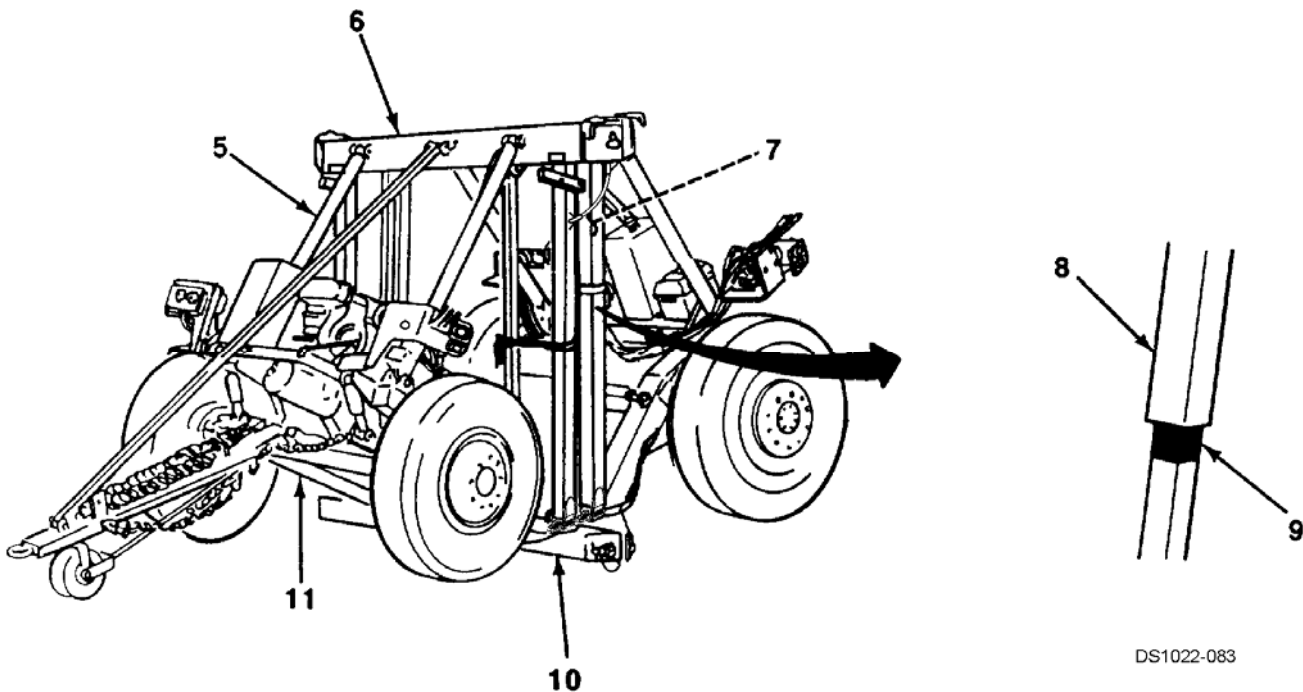
DS1022-180

**4-113. HYDRAULIC SYSTEM BLEEDING (M1022A1 WITH SIDE LIFT KIT) (Cont).**

**NOTE**

**During extension, maintain slack in hoist sling as top beams are raised.**

7. At front and rear, operate hydraulic control valve to extend hydraulic lift cylinders (5) until axle assembly (11) is approximately horizontal. Extend hydraulic positioning cylinders (7) until bottom beams (10) rest on the ground (see paragraph 2-21). Keep top beams (6) and bottom beams vertical as hydraulic cylinders are extended.
8. Repeat alternating extension of hydraulic lift cylinders (5) and hydraulic positioning cylinders (7), maintaining top and bottom beams (6 and 10) vertical. Stop when top beam vertical tubes (8) have extended approximately 49 in. (124 cm) and hydraulic positioning cylinder limit lines (9) are visible.



**NOTE**

**During retraction, maintain slack in hoist sling as top beams are lowered**

9. At front and rear, operate hydraulic control valves to retract hydraulic lift cylinders (5) until bottom beams (10) rest on the ground. Retract hydraulic positioning cylinders (7) until axle assembly (11) is approximately horizontal (see paragraph 2-21). Keep top beams (6) and bottom beams vertical as cylinders are retracted.
10. Repeat alternating retraction of hydraulic lift cylinders (5) and hydraulic positioning cylinders (7) maintaining top and bottom beams (6 and 10) vertical. Stop when hydraulic cylinders are fully retracted.
11. At front and rear, shut down engine (see paragraph 2-20).
12. Fill hydraulic reservoirs to top line on dipstick (see paragraph 3-7).
13. At front and rear, start engine (see paragraph 2-20).

---

**4-113. HYDRAULIC SYSTEM BLEEDING (MI022A1 WITH SIDE LIFT KIT) (Con't).**


---

**NOTE**

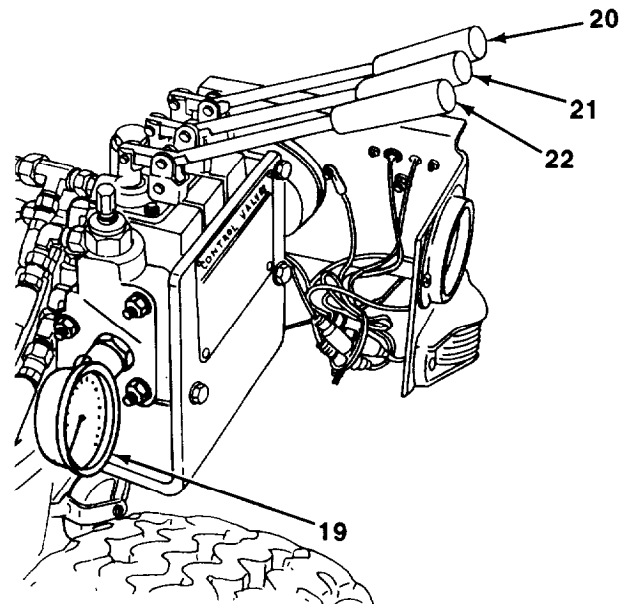
During extension, maintain slack In hoist sling as top beams are raised.

14. At front and rear, operate hydraulic control valve to SIMULTANEOUSLY extend hydraulic lift cylinders (5) and hydraulic positioning cylinders (7). Throughout extension, maintain top and bottom beams (6 and 10) vertical.
15. When full extension is reached, hold each hydraulic control valve lever (20,21, and 22) in the extend position until pressure gage (19) reads 2000 psi (13,790 kPa).

**NOTE**

If fluid level In hydraulic reservoir Is sufficient, a cylinder piston seal leak should be Investigated.

16. If 2000 psi (13,790 kPa) is not developed, check hydraulic fluid level in reservoirs (see paragraph 3-7).

**NOTE**

During retraction, maintain slack In hoist sling as top beams are lowered.

17. At front and rear, operate hydraulic control valve to SIMULTANEOUSLY retract hydraulic lift cylinders (5) and hydraulic positioning cylinders (7). Throughout retraction, maintain top and bottom beams (6 and 10) vertical.

**NOTE**

If 2000 psi (13,790 kPa) Is not developed, a cylinder piston seal leak should be investigated.

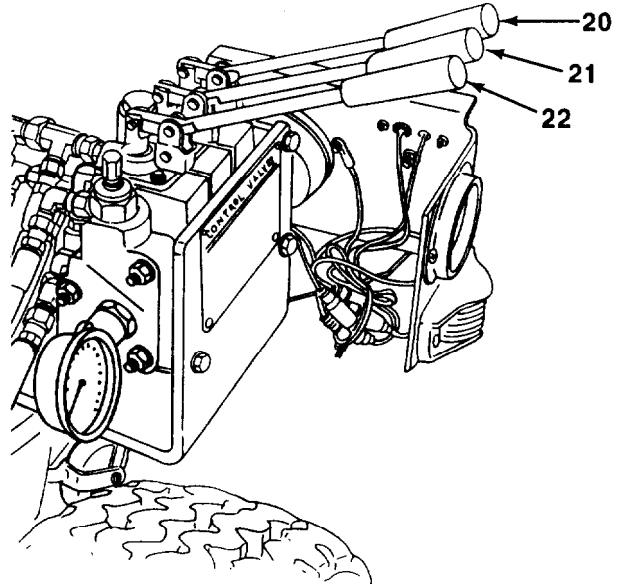
18. When full retraction is reached, hold each hydraulic control valve lever (20,21, and 22) in the retract position until pressure gage (19) reads 2000 psi (13,790 kPa).
19. At front and rear, shut down engine (see paragraph 2-20).
20. Fill hydraulic reservoirs to top line on dipstick (see paragraph 3-7).
21. At front and rear, start engine (see paragraph 2-20).
22. Repeat steps 7 and 8 to alternately fully extend hydraulic lift cylinders (5) and hydraulic positioning cylinders (7).

---

**4-113. HYDRAULIC SYSTEM BLEEDING (M1022A1 WITH SIDE LIFT KIT) (Con?).**

---

- 23. At front and rear, hold each near (left side) hydraulic lift cylinder lever (22) in extend position for 30 seconds.
- 24. At front and rear, hold each far (right side) hydraulic lift cylinder lever (21) in extend position for 30 seconds.
- 25. At front and rear, hold hydraulic positioning cylinders lever (20) in extend position for 30 seconds.

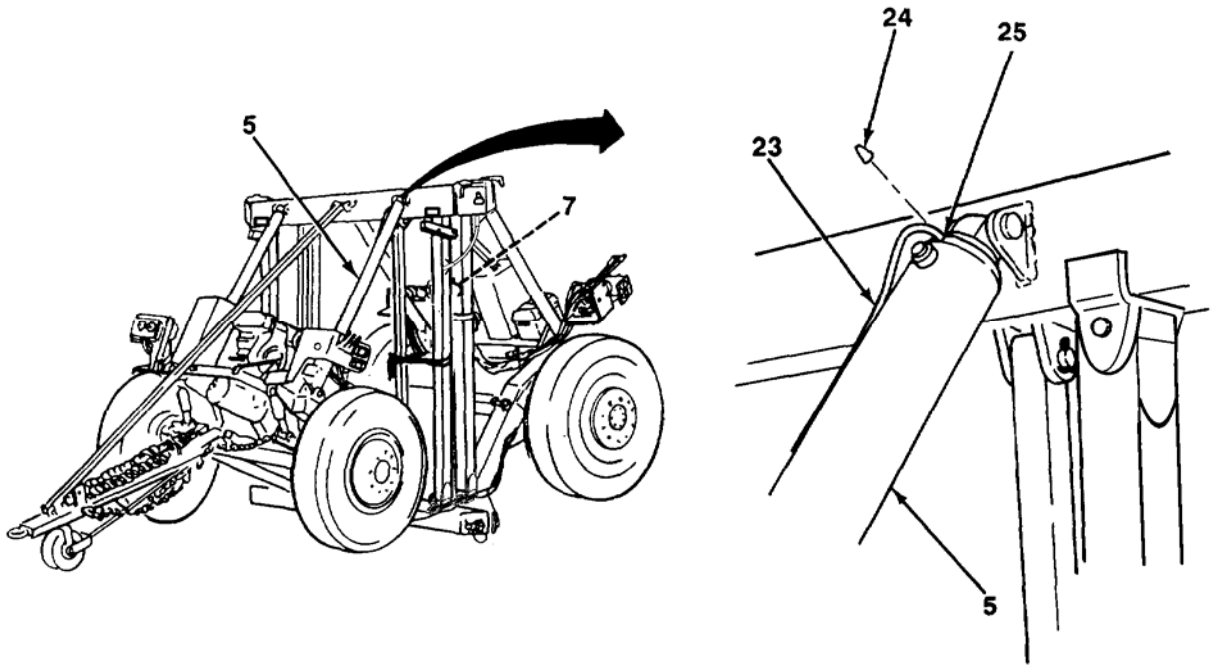


- 26. Repeat steps 9 and 10 to alternately fully retract hydraulic lift cylinders (5) and hydraulic positioning cylinders (7).
- 27. At front and rear, hold each near (left side) hydraulic lift cylinder lever (22) in retract position for 30 seconds.
- 28. At front and rear, hold each far (right side) hydraulic lift cylinder lever (21) in retract position for 30 seconds.
- 29. At front and rear, hold hydraulic positioning cylinders lever (20) in retract position for 30 seconds.
- 30. At front and rear, shut down engine (see paragraph 2-20).
- 31. Fill hydraulic reservoirs to top line on dipstick (see paragraph 3-7).
- 32. At front and rear, start engine (see paragraph 2-20).
- 33. Repeat steps 22 through 29 two more times.
- 34. At front and rear, remove cap (24) and connect a bleeder hose (23) to air bleeder (25) on hydraulic lift cylinder (5). Route other end of bleeder hose back into hydraulic reservoir.
- 35. Repeat steps 7 and 8 to alternately fully extend hydraulic lift cylinders (5) and hydraulic positioning cylinders (7).

---

**4-113. HYDRAULIC SYSTEM BLEEDING (M1022A1 WITH SIDE LIFT KIT) (Cont).**


---



<b>WARNING</b>
----------------

**Use extreme caution when using ladder. Have an assistant hold ladder to ensure that it is stable. Failure to follow this warning may cause serious injury to personnel.**

36. At front and rear, use flare nut wrench to open air bleeder (25) while holding each hydraulic control valve lever (20,21, and 22) in the extend position. Continue to hold hydraulic control valve levers in the extend position until a steady flow of hydraulic fluid flows from bleeder hose (23). Close air bleeder.
37. Repeat steps 9 and 10 to alternately fully retract hydraulic lift cylinders (5) and hydraulic positioning cylinders (7).

<b>WARNING</b>
----------------

**Use extreme caution when using ladder. Have an assistant hold ladder to ensure that it is stable. Failure to follow this warning may cause serious injury to personnel.**

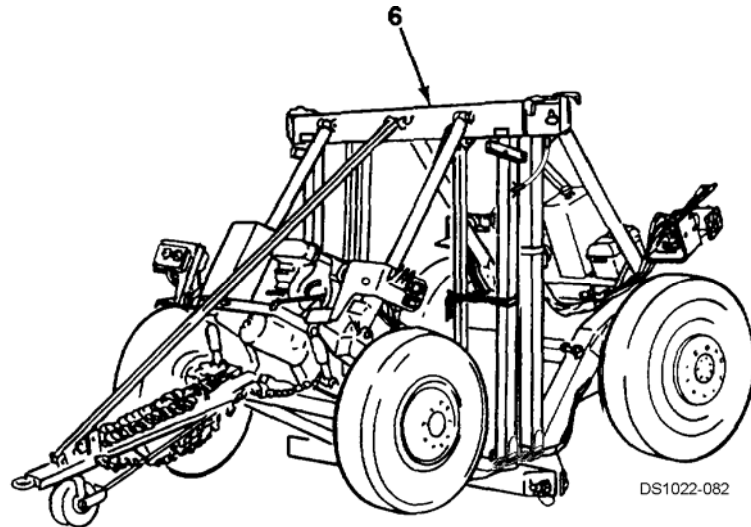
38. At front and rear, use flare nut wrench to open air bleeder (25) while holding each hydraulic control valve lever (20,21, and 22) in the retract position. Continue to hold hydraulic control valve levers in the retract position until a steady flow of hydraulic fluid flows from bleeder hose (23). Close air bleeder and torque to 180 lb.-in.(20 N-m).
39. Install cap (24) on air bleeder (25).
40. At front and rear, shut down engine (see paragraph 2-20).
41. Fill hydraulic reservoirs to top line on dipstick (see paragraph 3-7).

---

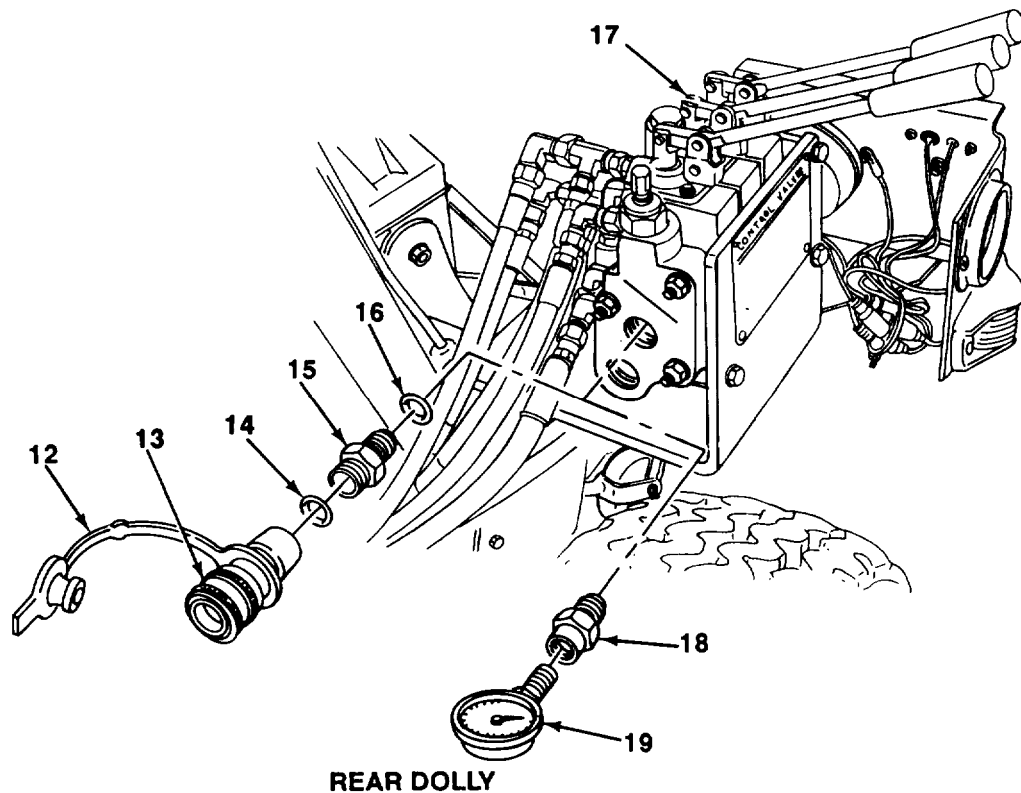
**4-113. HYDRAULIC SYSTEM BLEEDING (M1022A1 WITH SIDE LIFT KIT) (Cont).**

---

42. Remove support from top beams (6).



43. Remove pressure gage (19) and pipe bushing (18) from inlet section of each hydraulic control valve (17).
44. Install new preformed packing (16), union (front dolly) or straight adapter (15) (rear dolly), dust cap (12), new preformed packing (14), and redundant power quick disconnect coupler (13) on inlet section of each hydraulic control valve (17). Install dust cap to redundant power quick disconnect coupler.

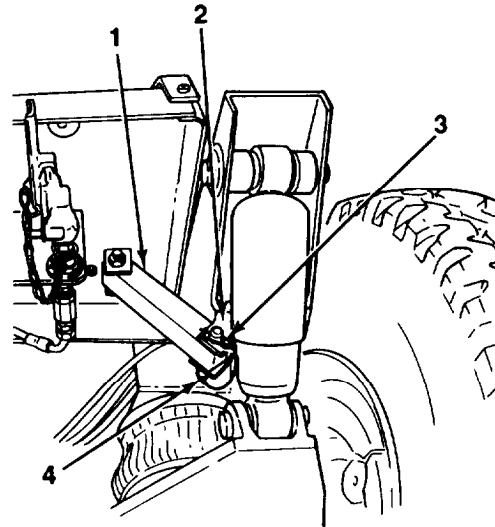


---

**4-113. HYDRAULIC SYSTEM BLEEDING (M1022A1 WITH SIDE LIFT KIT) (Con't).**

---

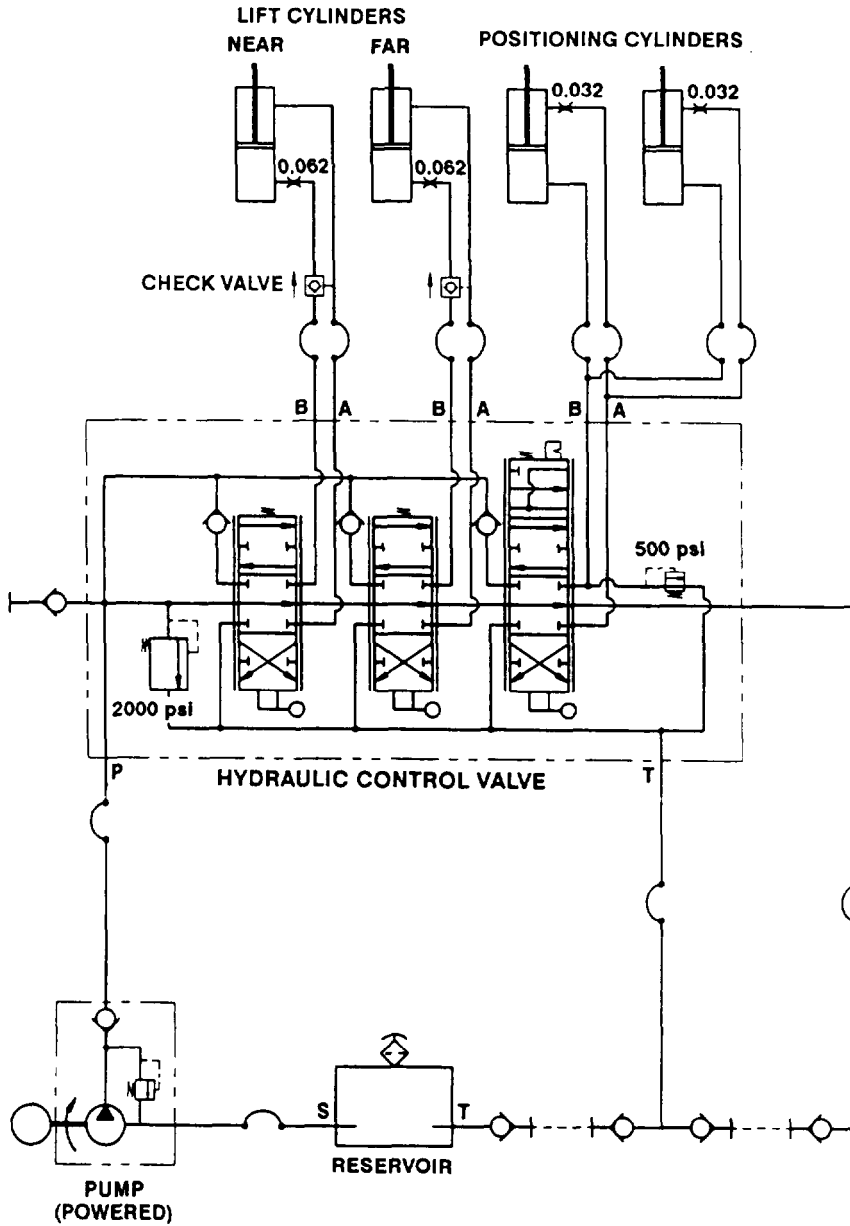
45. At front and rear, install hitch pin (4) and safety pin (3) and lock pivoting tray lockout brace (1) on lower bracket (2).

**Follow-on Tasks:**

- Deflate air bags (see paragraph 2-22).
- Stow all removed items on bottom beams as required (see paragraph 2-10).
- Remove steering locking pin from steering link.

4-114. HYDRAULIC SYSTEM SCHEMATICS.

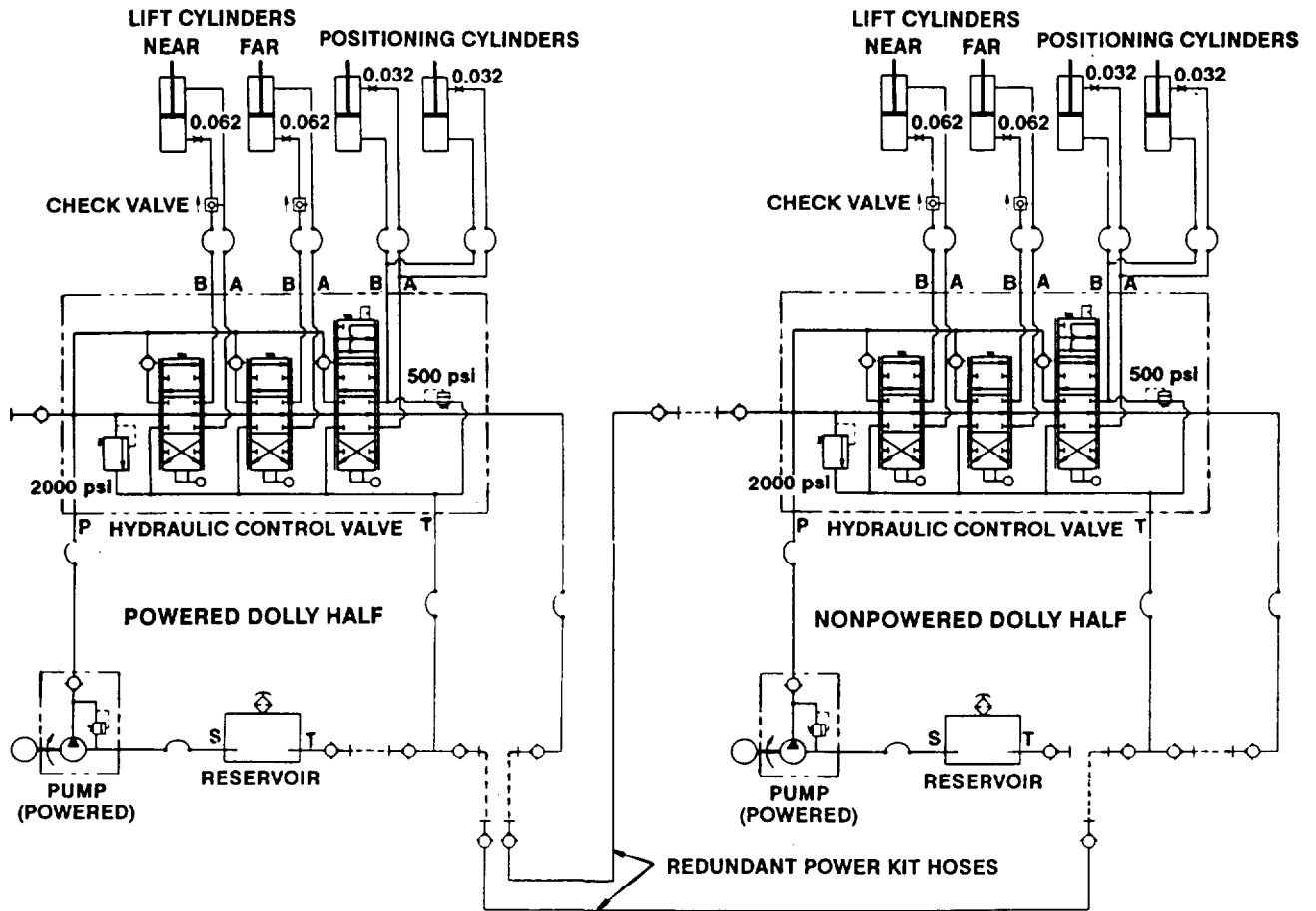
The following schematics identify the hydraulic system components and their interrelationships during normal or redundant power operations.



FRONT OR REAR DOLLY-NORMAL OPERATION



4-114. HYDRAULIC SYSTEM SCHEMATICS (Con't).



FRONT AND REAR DOLLIES-REDUNDANT POWER OPERATION



**Section XVI. ENGINE MAINTENANCE**

Paragraph Number	Paragraph Title	Page Number
4-115.	Engine Replacement .....	4-327
4-116.	Flywheel Assembly and Stator Assembly Replacement .....	4-332
4-117.	Oil Cooler and Rocker Arm Covers Replacement .....	4-337
4-118.	Crankcase Oil and Oil Filter Replacement .....	4-340
4-119.	Oil Cooler Lines Replacement .....	4-344
4-120.	Injection Pump Replacement .....	4-346
4-121.	Nozzle Holder Replacement .....	4-350
4-122.	Fuel Lines Replacement .....	4-352
4-123.	Air Cleaner Maintenance .....	4-357
4-124.	Fuel Filter and Strainer Replacement .....	4-362
4-125.	Fuel Tank Maintenance .....	4-366
4-126.	Side Cover Replacement .....	4-374
4-127.	Muffler Replacement .....	4-375
4-128.	Cylinder Cowling and Spiral Case Replacement. ....	4-378
4-129.	Regulator Replacement .....	4-380
4-130.	Starter Replacement .....	4-382
4-131.	Starter Switch Assembly Replacement .....	4-384
4-132.	Engine Wiring Harness Replacement .....	4-386
4-133.	Glow Plug Replacement .....	4-390
4-134.	Winterizing Engine [Below 0°F (-18°C)] .....	4-392
4-135.	Engine Wiring Diagram .....	4-394

---

**4-115. ENGINE REPLACEMENT.**

---

This Task Covers:

- |            |                 |
|------------|-----------------|
| a. Removal | b. Installation |
|------------|-----------------|
- 

Initial Setup:

Equipment Conditions:

- Dolly set lowered (see paragraph 2-8).
- Battery cables removed (see paragraph 4-45).
- Fuel tank drained (see paragraph 4-125).
- Hydraulic hose assemblies inside abrasion sleeve (hose bundle) detached from muffler cover (See paragraph 4-109).

Materials/Parts:

- Hydraulic fluid (Item 15, Appendix F)
- Rags (Item 25, Appendix F)
- Marker tags (Item 28, Appendix F)
- Eight locknuts

Personnel Required: Two

Tools/Test Equipment:

- General mechanic's tool kit (Item 30, Appendix G).
  - Wooden blocks.
-

---

4-115. ENGINE REPLACEMENT (Con't).

---

**a. REMOVAL**

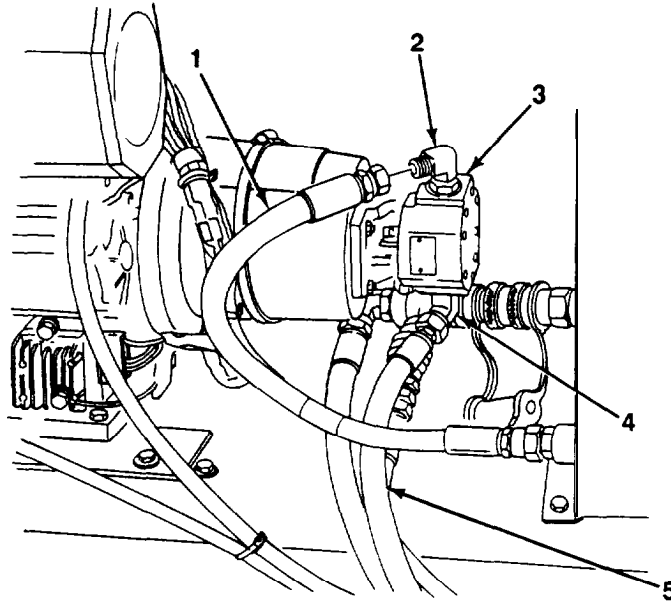
**WARNING**

- DO NOT disconnect hydraulic lines and fittings while engine is running or before hydraulic system pressure has been released. When engine is running, hydraulic system is under pressure. Dolly set must be fully lowered to the ground and engine must be shut down before lines and fittings are disconnected. A line or fitting disconnected under pressure will explode with great force and cause serious injury or death to personnel.
- Escaping hydraulic fluid under pressure can penetrate the skin, causing serious injury to personnel. Relieve pressure before disconnecting hydraulic lines and fittings. Tighten all connections before applying pressure. Keep hands and body away from pinholes and nozzles which eject hydraulic fluid high under pressure. Use a piece of cardboard or paper to search for leaks. If any hydraulic fluid is injected into the skin, it MUST be surgically removed within a few hours by a doctor familiar with this type of injury or gangrene may result.

**NOTE**

- Hydraulic lines should be tagged before removal. Refer to paragraph 4-18 for tagging instructions.
- A suitable container should be used to catch any draining hydraulic fluid. Ensure that all spills are properly cleaned.

1. Disconnect hose assembly (1) from elbow (2) at inlet (top) of hydraulic pump (3). Drain hydraulic fluid into a suitable container.



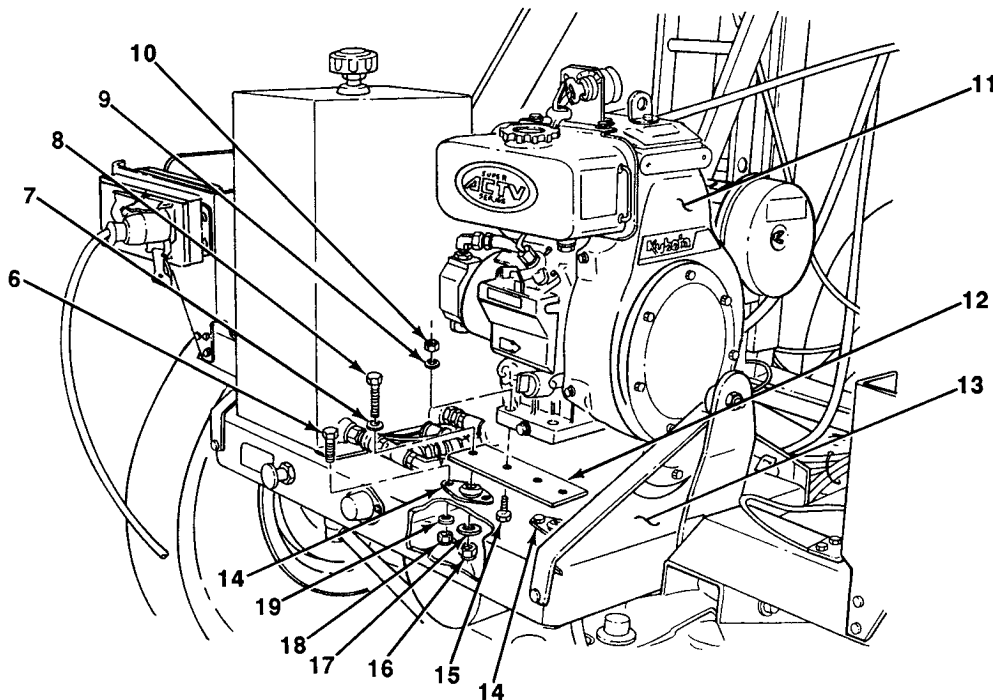
## 4-115. ENGINE REPLACEMENT (Con't).

2. Disconnect hose assembly (5) from elbow (4) at outlet (bottom) of hydraulic pump (3). Drain hydraulic fluid into a suitable container.

**WARNING**

**Use extreme caution when handling heavy parts. Lifting device is required when parts weigh over 50 lb (23 kg) for a single person lift, over 100 lb (45 kg) for a two person lift, and over 150 lb (68 kg) for a three or more person lift. Keep clear of heavy parts supported only by lifting device. Failure to follow this warning may cause serious injury or death to personnel.**

3. Remove four locknuts (16), snubbing washers (17), capscrews (8), and flatwashers (7) from four isolator mounts (14) and two mounting plates (12). Discard locknuts.
4. Remove engine (11) and two mounting plates (12) as an assembly from pivoting tray (13). Place on wooden blocks.



5. Remove four locknuts (10), flatwashers (9), capscrews (15), and engine (11) from two mounting plates (12). Discard locknuts.
6. If isolator mounts (14) are damaged, remove eight locknuts (18), flatwashers (19), capscrews (6), and four isolator mounts from pivoting tray (13). Discard locknuts.
7. Remove hydraulic pump from engine (see paragraph 4-107).

## 4-115. ENGINE REPLACEMENT (Con't).

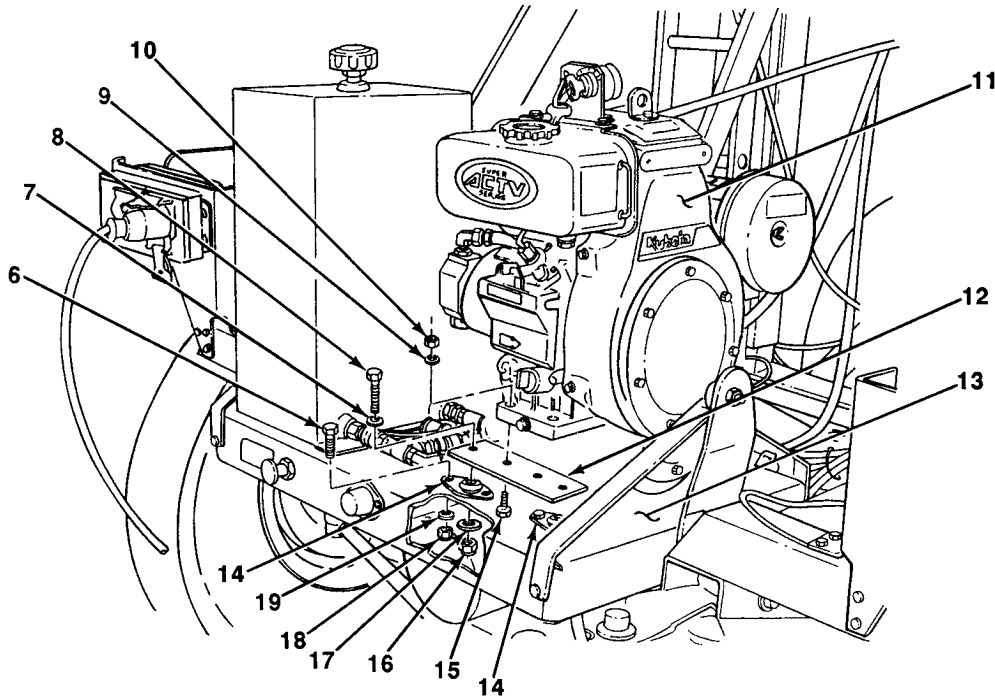
### a. INSTALLATION

1. Install hydraulic pump on engine (see paragraph 4-107).
2. If removed, install four isolator mounts (14) on pivoting tray (13) with eight capscrews (6), flatwashers (19), and new locknuts (18).

### WARNING

**Use extreme caution when handling heavy parts. Lifting device is required when parts weigh over 50 lb (23 kg) for a single person lift, over 100 lb (45 kg) for a two person lift, and over 150 lb (68 kg) for a three or more person lift. Keep clear of heavy parts supported only by lifting device. Failure to follow this warning may cause serious injury or death to personnel.**

3. Install engine (11) on two mounting plates (12) with four capscrews (15), flatwashers (9), and new locknuts (10).



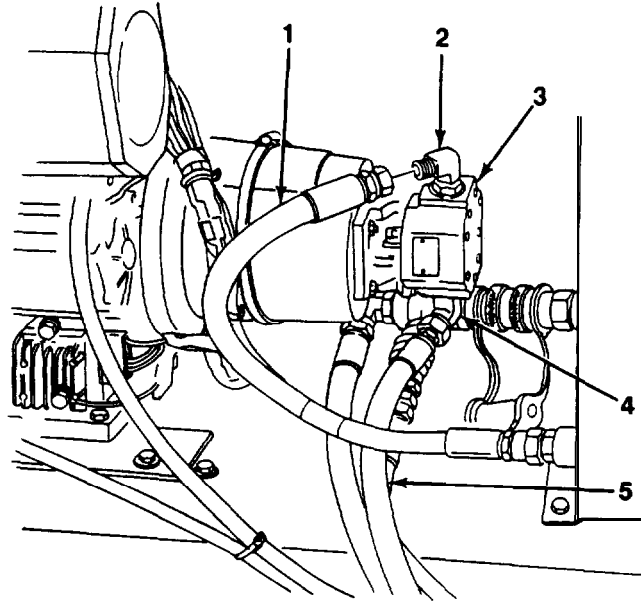
4. Position engine (11) with two mounting plates (12) at pivoting tray (13) with holes in mounting plates aligned with holes in isolator mounts (14).
5. Install four flatwashers (7), capscrews (8), snubbing washers (17), and new locknuts (16) on four isolator mounts (14) and two mounting plates (12).

---

**4-115. ENGINE REPLACEMENT (Con't).**

---

6. Connect hose assembly (5) to elbow (4) at outlet (bottom) of hydraulic pump (3).
7. Connect hose assembly (1) to elbow (2) at inlet (top) on hydraulic pump (3).

**Follow-on Tasks:**

- Attach hydraulic hose assemblies inside abrasion sleeve (hose bundle) to muffler cover (see paragraph 4-109).
- Fill fuel tank (see paragraph 3-9 or 4-125).
- Fill hydraulic reservoir with hydraulic fluid (see paragraph 3-7).
- Install battery cables (see paragraph 4-45).
- Start engine (see paragraph 2-20) and check operation of engine.

---

## 4-116. FLYWHEEL ASSEMBLY AND STATOR ASSEMBLY REPLACEMENT.

---

*This Task Covers:*

- a. Removal
- b. Cleaning and Inspection
- C. Installation

---

*Initial Setup:*

### Equipment Conditions:

- Engine removed (see paragraph 4-115).
- Spiral case removed (see paragraph 4-128).

### Tools/Test Equipment:

- General mechanic's tool kit (Item 30, Appendix G)
- Compressor unit (Item 4, Appendix G)
- Mechanical puller kit (Item 22, Appendix G)
- Torque wrench, 0-175 lb.-ft. (Item 42, Appendix G)

### Materials/Parts:

- Rags (Item 25, Appendix F)
- Dry cleaning solvent (Item 27, Appendix F)
- Marker tags (Item 28, Appendix F)
- Three socket head capscrews, M6 x 1.00

### Personnel Required: Two

### General Safety Instructions:

- Dry cleaning solvent is flammable and must not be used near an open flame. Use only in a well-ventilated area.
- Compressed air used for cleaning purposes should never exceed 30 psi (207 kPa).

---

### NOTE

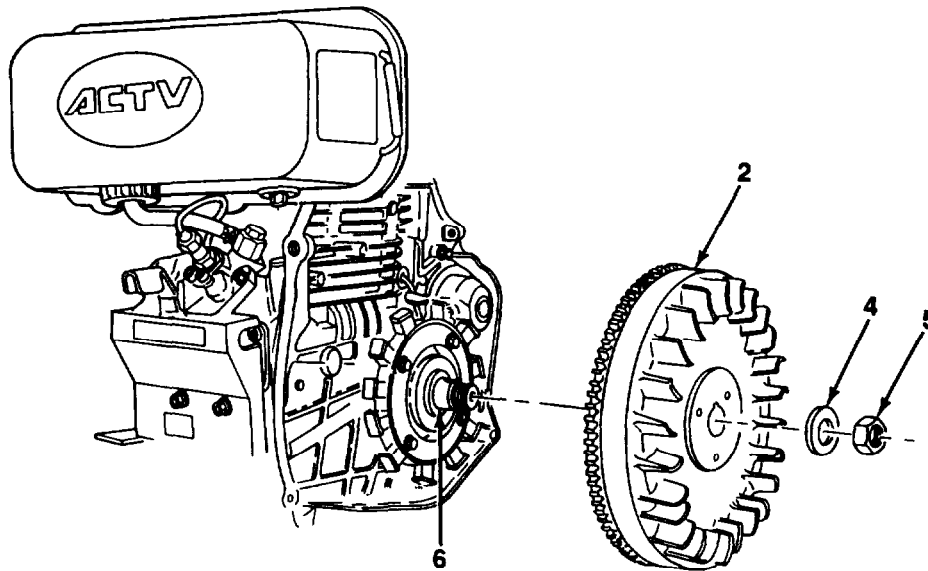
All wires should be tagged before removal. Refer to paragraph 4-18 for tagging Instructions.

### **a. REMOVAL**

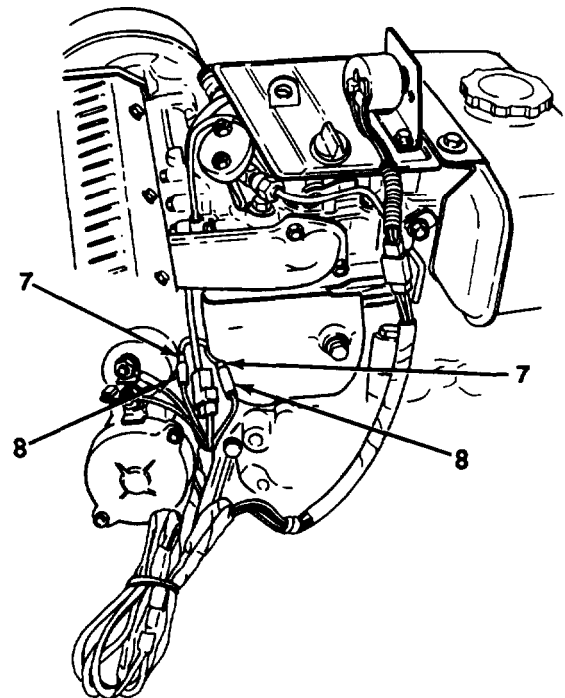
1. Hold flywheel (2) and remove nut (5) and washer (4) from crankshaft (6).
2. Install mechanical puller on flywheel (2) using three socket head capscrews.
3. Using mechanical puller, remove flywheel (2) from crankshaft (6).
4. Remove three socket head capscrews and mechanical puller from flywheel (2).



4-116. FLYWHEEL ASSEMBLY AND STATOR ASSEMBLY REPLACEMENT (Con't).



5. Disconnect two wiring harness connectors (8) from stator assembly connectors (7).



---

**4-116. FLYWHEEL ASSEMBLY AND STATOR ASSEMBLY REPLACEMENT (Con't).**

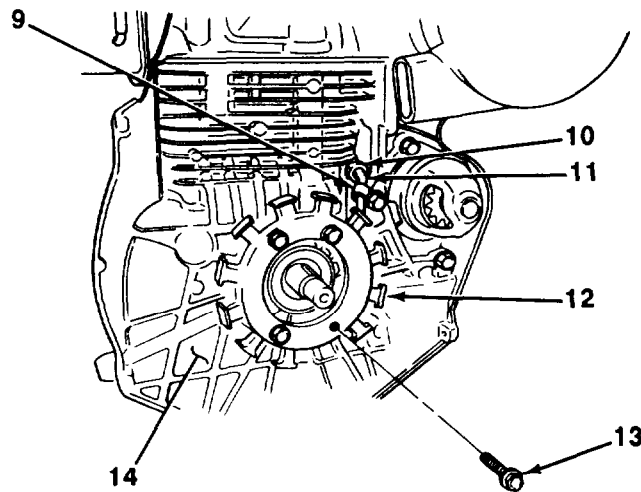
---

6. Release clamp (9) from stator assembly lead (11).
7. Remove grommet (10) from hole in crankcase (14). Pull stator assembly lead (11) through hole.

**NOTE**

Note location of stator assembly to aid during Installation.

8. Remove four flange bolts (13) and stator assembly (12) from crankcase (14).



**b. CLEANING AND INSPECTION**



- Dry cleaning solvent, P-D-680, is toxic and flammable. Always wear protective goggles and gloves, and use only in a well-ventilated area. Avoid contact with skin, eyes, and clothes, and DO NOT breathe vapors. DO NOT use near open flame or excessive heat. The solvent's flash point is 100°F-138°F (38°C-59°C). If you become dizzy while using cleaning solvent, immediately get fresh air and medical help. If solvent contacts eyes, immediately wash your eyes and seek medical attention.
- Compressed air used for cleaning or drying purposes, or for clearing restrictions, should never exceed 30 psi (207 kPa). Wear protective clothing (goggles/shield, gloves, etc.) and use caution to avoid injury to personnel.

1. Clean all removed components, except grommet, with dry cleaning solvent and dry with compressed air.

---

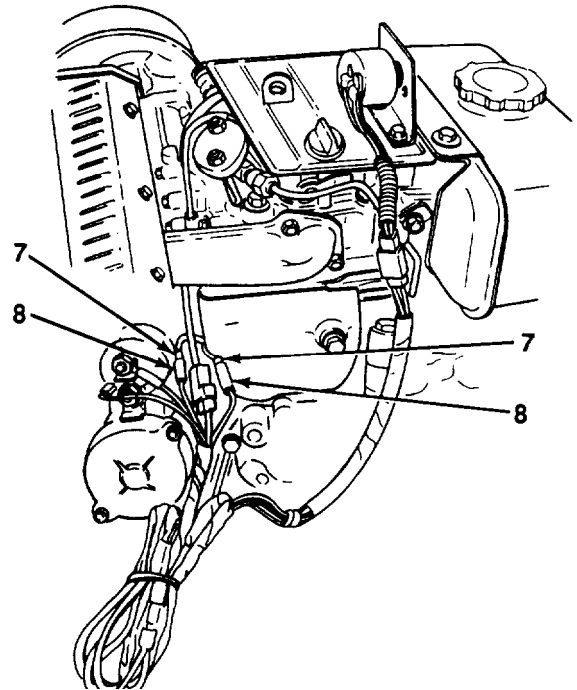
**4-116. FLYWHEEL ASSEMBLY AND STATOR ASSEMBLY REPLACEMENT (Con't).**

---

2. Ensure that end of crankshaft and tapered section of flywheel are free of grease. Clean all material from rotor magnet with a clean rag.
3. Inspect flywheel and ring gear for cracks, breaks, and broken fins or teeth. If teeth are broken or missing, replace flywheel assembly.
4. Inspect stator assembly for broken windings, burned condition, or broken leads. Replace damaged stator.
5. Inspect grommet for damage. Replace damaged grommet.

**c. INSTALLATION**

1. Install stator assembly (12) on crankcase (14) with four flange bolts (13).
2. Feed stator assembly lead (11) through hole in crankcase (14) and install grommet (10).
3. Secure stator assembly lead (11) to crankcase (14) with clamp (9).
4. Connect two stator assembly connectors (7) to wiring harness connectors (8).

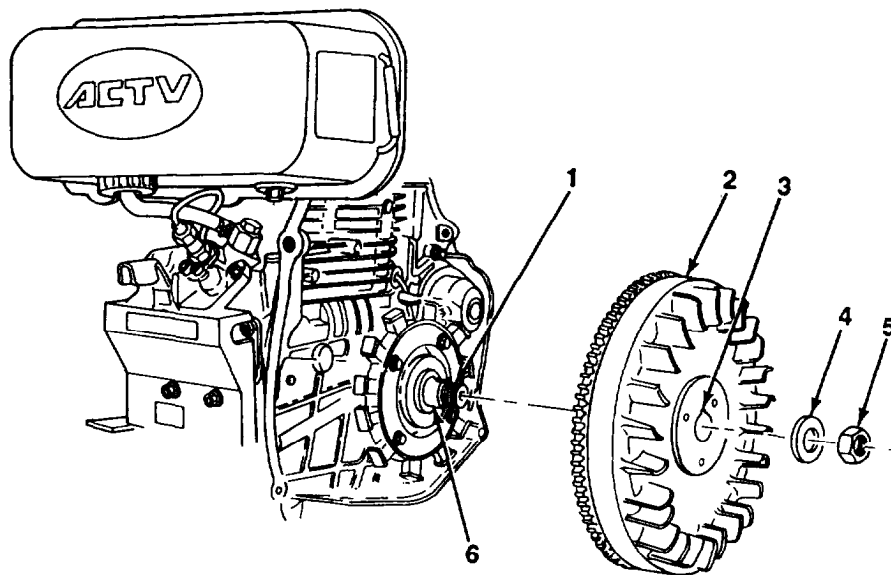


---

4-116. FLYWHEEL ASSEMBLY AND STATOR ASSEMBLY REPLACEMENT (Con't).

---

5. Position flywheel (2) at crankshaft (6) with flywheel keyway (3) aligned with crankshaft key (1).
6. Install washer (4) and nut (5) on crankshaft (6).
7. Hold flywheel (2) and tighten nut (5). Torque nut to 101-116 lb.-ft. (137-157 N·m).



Follow-on Tasks:

- Install spiral case (see paragraph 4-128).
- Install engine (see paragraph 4-115).

---

**4-117. OIL COOLER AND ROCKER ARM COVERS REPLACEMENT.**

---

This Task Covers:

- a. Removal
  - b. Cleaning and Inspection
  - C. Installation
- 

*Initial Setup:*

**Equipment Conditions:**

- Starter switch assembly removed (see paragraph 4-131).

**Tools/Test Equipment:**

- General mechanic's tool kit (Item 30, Appendix G)
- Compressor unit (Item 4, Appendix G)

**Materials/Parts:**

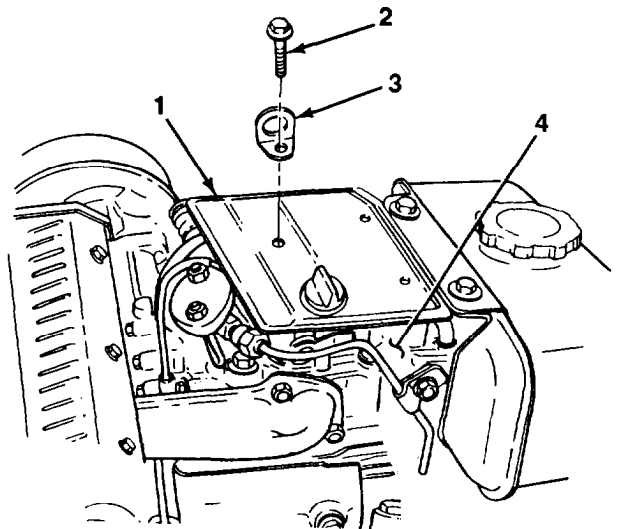
- Dry cleaning solvent (Item 27, Appendix F)
- One gasket

**General Safety Instructions:**

- Dry cleaning solvent is flammable and must not be used near an open flame. Use only in a well-ventilated area.
  - Compressed air used for cleaning purposes should never exceed 30 psl (207 kPa).
- 

**a. REMOVAL**

1. Remove bolt (2) lifting hook (3), and oil cooler cover (1) from rocker arm cover (4).

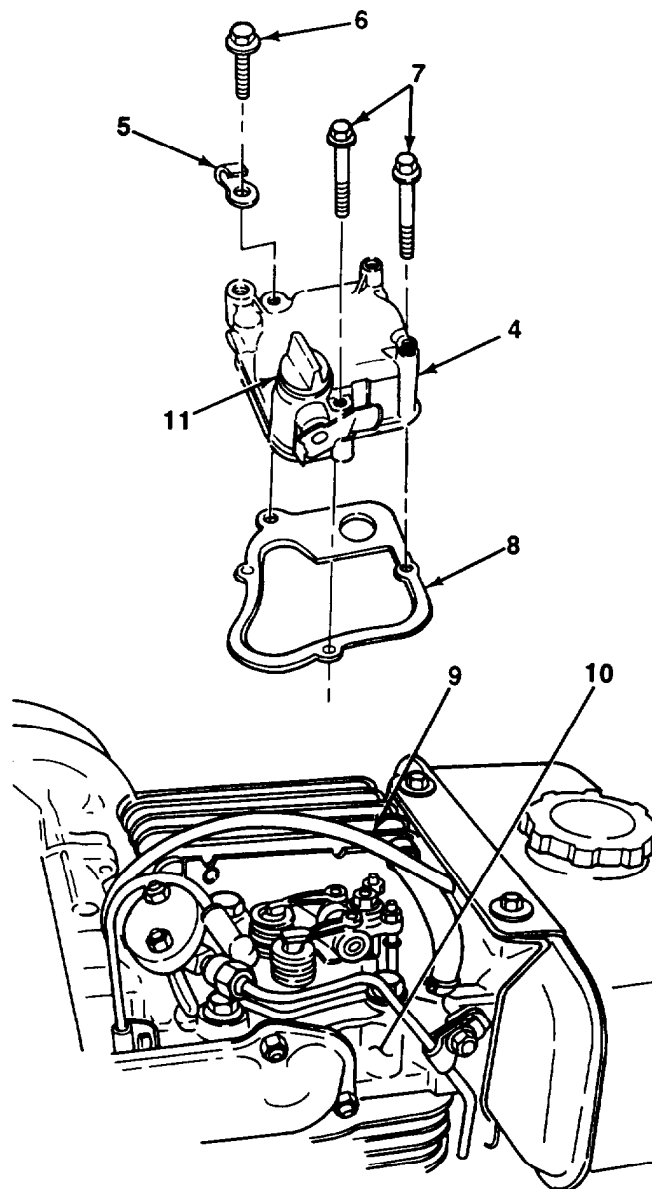


---

**4-117. OIL COOLER AND ROCKER ARM COVERS REPLACEMENT (Con't).**

---

2. Remove two bolts (7), bolt (6), clamp (5) with fuel overflow hose (9), rocker arm cover (4), and gasket (8) from cylinder head (10). Discard gasket.
3. If replacing rocker arm cover (4), remove oil filler plug (11) and O-ring.



---

**4-117. OIL COOLER AND ROCKER ARM COVERS REPLACEMENT (Con't).**

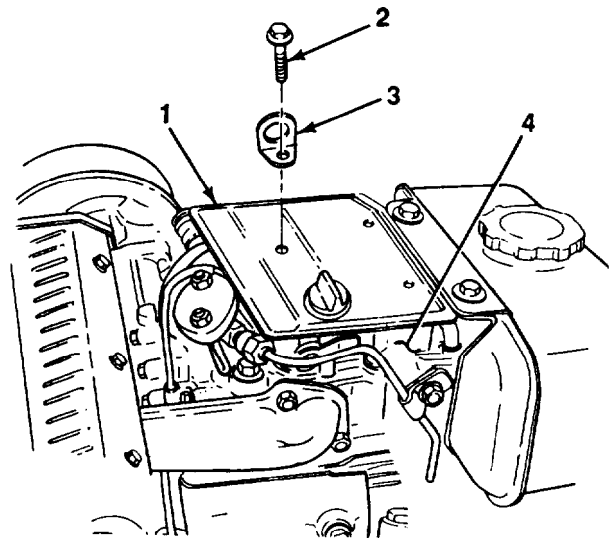

---

**b. CLEANING AND INSPECTION**


- Dry cleaning solvent, P-D-680, is toxic and flammable. Always wear protective goggles and gloves, and use only in a well-ventilated area. Avoid contact with skin, eyes, and clothes, and DO NOT breathe vapors. DO NOT use near open flame or excessive heat. The solvent's flash point is 100°F-138°F (38°C-59°C). If you become dizzy while using cleaning solvent, immediately get fresh air and medical help. If solvent contacts eyes, immediately wash your eyes and seek medical attention.
  - Compressed air used for cleaning or drying purposes, or for clearing restrictions, should never exceed 30 psi (207 kPa). Wear protective clothing (goggles/shield, gloves, etc.) and use caution to avoid injury to personnel.
1. Clean all removed components with dry cleaning solvent and dry with compressed air. Ensure that gasket mounting surface on rocker arm cover and cylinder head is clean and dry.
  2. Inspect all removed components for cracks, breaks, bends, corrosion, or other damage. Replace damaged components.

**c. INSTALLATION**

1. If removed, install oil filler plug (11) and O-ring to rocker arm cover (4).
2. Install new gasket (8) and rocker arm cover (4) on cylinder head (10) with clamp (5) with fuel overflow hose (9), bolt (6) and two bolts (7).
3. Install oil cooler cover (1) lifting hook (3), and bolt (2) on rocker arm cover (4).


**Follow-on Tasks:**

- Install starter switch assembly (see paragraph 4-131).

---

## 4-118. CRANKCASE OIL AND OIL FILTER REPLACEMENT.

---

This Task Covers:

- a. Removal
- b. Cleaning and Inspection
- c. Installation

Initial Setup:

### Equipment Conditions:

- Engine warm.
- Engine starter switch set to OFF position (see paragraph 2-20).

### Materials/Parts:

- Lubricating oil (Item 21, 22, or 23, Appendix F)
- Rags (Item 25, Appendix F)
- Dry cleaning solvent (Item 27, Appendix F)

### Tools/Test Equipment:

- General mechanic's tool kit (Item 30, Appendix G)
- Compressor unit (Item 4, Appendix G)

### General Safety Instructions:

- Dry cleaning solvent is flammable and must not be used near an open flame. Use only in a well-ventilated area.
- Compressed air used for cleaning purposes should never exceed 30 psi (207 kPa).

---

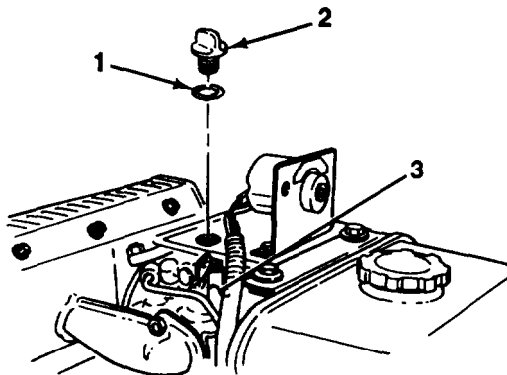
### CAUTION

DO NOT allow dirt or dust to enter crankcase. Damage to engine will result.

### NOTE

- Perform steps 1 through 5 to drain crankcase oil.
- A suitable container should be used to catch any draining lubricating oil. Ensure that all spills are properly cleaned.

1. Remove oil filler plug (2) and O-ring (1) from rocker arm cover (3).



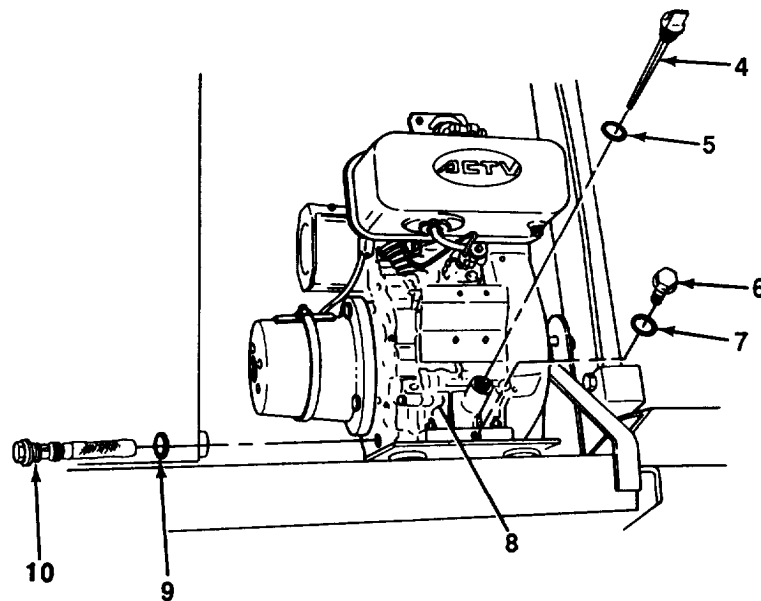
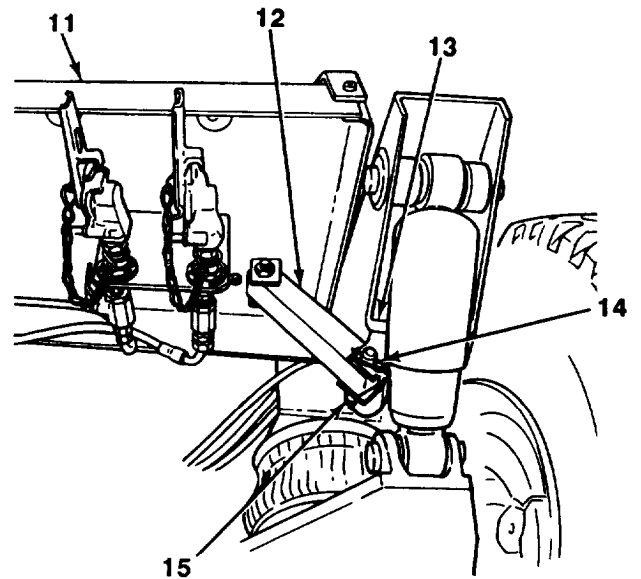


---

**4-118. CRANKCASE OIL AND OIL FILTER REPLACEMENT (Con't).**


---

2. Loosen drain plug (6).
3. Remove safety pin (14) and hitch pin (15) and unlock pivoting tray lockout brace (12) from lower bracket (13). Tip pivoting tray (11) so that front edge is facing downward.
4. Remove drain plug (6) and gasket (7) from crankcase (8). Drain lubricating oil into a suitable container.
5. Inspect drain plug (6) and gasket (7) for damage. If okay, install on crankcase (9). If damaged, install new gasket and new drain plug on crankcase.
6. Remove dipstick (4) and O-ring (5) from crankcase (8).
7. Remove oil filter (10) and preformed packing (9) from crankcase (8).



---

4-118. CRANKCASE OIL AND OIL FILTER REPLACEMENT (Con't).

---

**b. CLEANING AND INSPECTION**



- Dry cleaning solvent, P-D-680, Is toxic and flammable. Always wear protective goggles and gloves, and use only In a well-ventilated area. Avoid contact with skin, eyes, and clothes, and DO NOT breathe vapors. DO NOT use near open flame or excessive heat. The solvent's flash point Is 100°F-138°F (38°C-59°C). If you become dizzy while using cleaning solvent, Immediately get fresh air and medical help. If solvent contacts eyes, Immediately wash your eyes and seek medical attention.
- Compressed air used for cleaning or drying purposes, or for clearing restrictions, should never exceed 30 psl (207 kPa). Wear protective clothing (goggles/shield, gloves, etc.) and use caution to avoid Injury to personnel.

1. Clean oil filter, dipstick, oil filler plug, O-rings, and preformed packing with dry cleaning solvent and dry with compressed air.
2. Inspect O-rings and preformed packings for damage. Replace damaged O-rings and preformed packings.
3. Inspect oil filter, dipstick, and oil filler plug for cracks, breaks, bends, or damaged threads. Replace damaged components.

**c. INSTALLATION**

NOTE

Preformed packing and O-rings should be lightly coated with lubricating oil before Installation.

1. Install preformed packing (9) and oil filter (10) on crankcase (8).
2. Install O-ring (5) and dipstick (4) in crankcase (8).

**CAUTION**

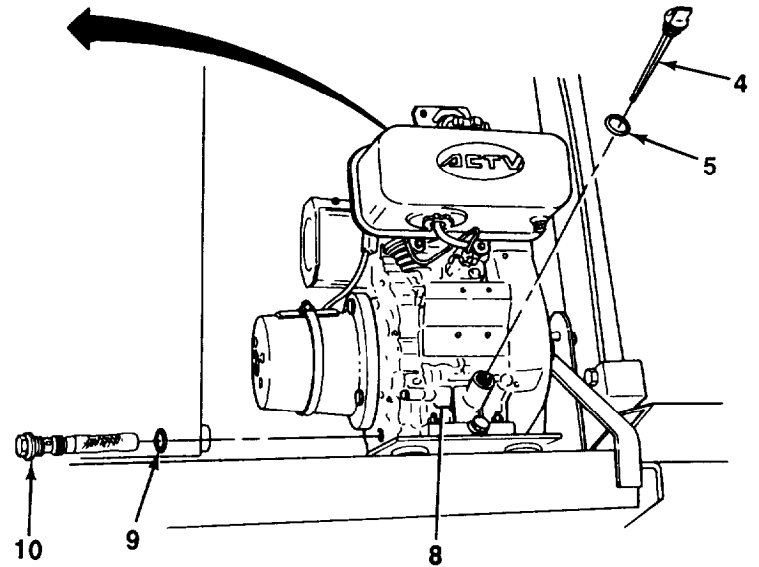
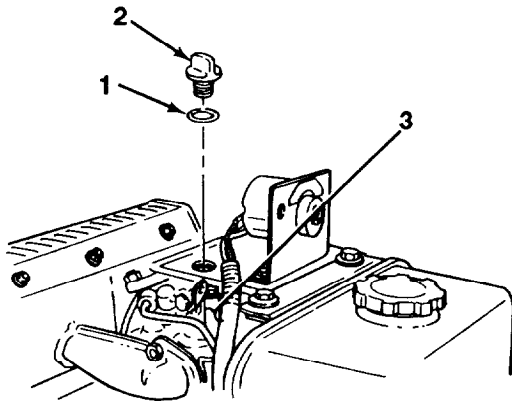
DO NOT overfill engine crankcase. Damage to engine will result.

NOTE

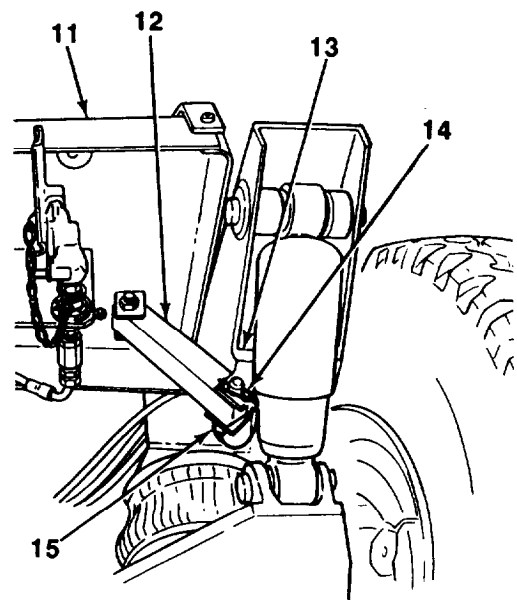
Capacity of crankcase Is 1.37 qt (1.30 l).

3. Fill crankcase (8) with lubricating oil through filler plug (2) opening.
4. Remove dipstick (4) from crankcase (8) and clean with a clean rag.
5. Install dipstick (4) in crankcase (8). Remove dipstick and check level of lubricating oil on dipstick-oil level must show on dipstick. Oil level is FULL if oil coats threads of dipstick.

4-118. CRANKCASE OIL AND OIL FILTER REPLACEMENT (Con't).



6. Add lubricating oil as required until reading on dipstick (4) is as specified in step 5.
7. Install O-ring (1) and filler plug (2) on rocker arm cover (3).
8. Lock pivoting tray lockout brace (12) on lower bracket (13) with hitch pin (15) and safety pin (14).



---

## 4-119. OIL COOLER LINES REPLACEMENT.

---

*This Task Covers:*

- a. Removal b. Installation
- 

*Initial Setup:*

**Equipment Conditions:**

- Oil cooler and rocker arm covers removed (see paragraph 4-117).
- Fuel tank and stay removed (see paragraph 4-125).

**Material/Parts:**

- Rags (Item 25, Appendix F)

**Tools/Test Equipment:**

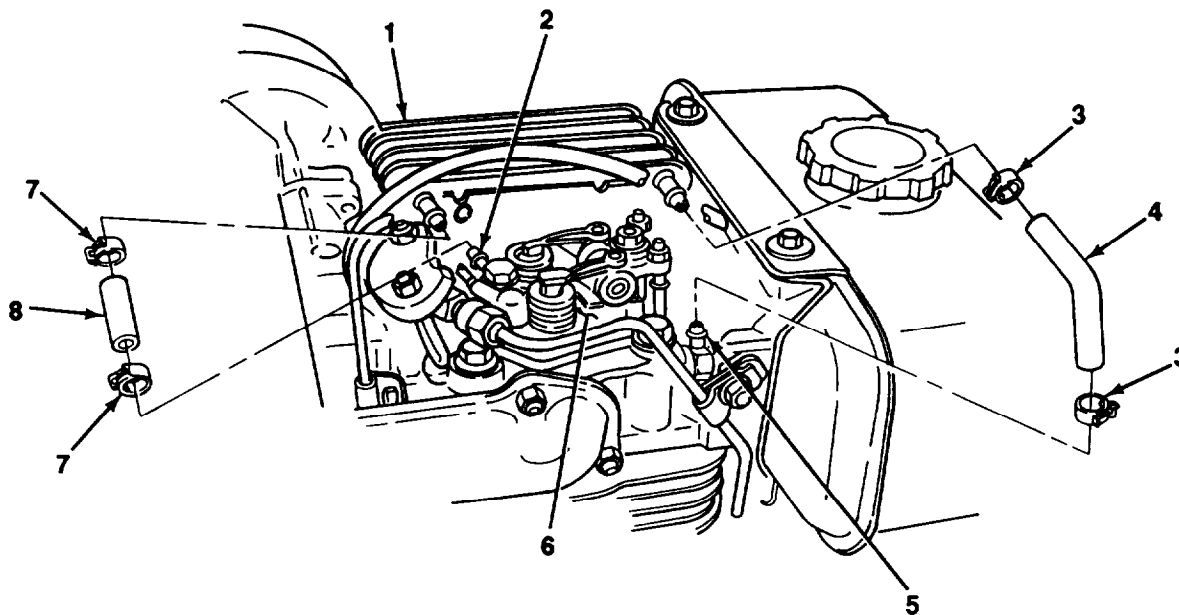
- General mechanic's tool kit (Item 30, Appendix G)
- 

**a. REMOVAL**

**NOTE**

Use rags as required to clean any oil spills.

1. Remove two clips (3) and oil pipe (4) from oil cooler (1) and joint (5) at side of cylinder head (6).
2. Remove two clips (7) and oil pipe (8) from oil cooler (1) and joint (2) at top of cylinder head (6).



---

**4-119. OIL COOLER LINES REPLACEMENT (Con't).**

---

**b. INSTALLATION**

1. Install oil pipe (8) and two clips (7) on oil cooler (1) and joint (2).
2. Install oil pipe (4) and two clips (3) on oil cooler (1) and joint (5).

**Follow-on Tasks:**

- Install stay and fuel tank (see paragraph 4-125).
- Install oil cooler and rocker arm covers (see paragraph 4-117).
- Start engine (see paragraph 2-20) and check for oil leaks.

---

## 4-120. INJECTION PUMP REPLACEMENT.

---

*This Task Covers:*

- |             |                      |
|-------------|----------------------|
| a. Removal  | c. Installation      |
| b. Cleaning | d. Timing Adjustment |
- 

*Initial Setup:*

### Equipment Conditions:

- Negative (-) ground cable disconnected from battery (rear dolly) (see paragraph 4-45).
- Engine removed (front dolly) (see paragraph 4-115).
- Fuel tank removed (see paragraph 4-125).
- Injection pipe removed (see paragraph 4-122).

### Tools/Test Equipment:

- General mechanic's tool kit (Item 30, Appendix G)
- Torque wrench, 0-200 lb.-in. (Item 41, Appendix G)

### Materials/Parts:

- Rags (Item 25, Appendix F)
- Dry cleaning solvent (Item 27, Appendix F)

**Personnel Required:** Two

### General Safety Instructions:

- DO NOT perform this procedure near fire, flames, or sparks.
  - Dry cleaning solvent is flammable and must not be used near an open flame. Use only in a well-ventilated area.
- 



**WARNING**

**Diesel fuel is combustible. DO NOT smoke or allow an open flame near fuel tank. Shut down engine when adding fuel. Failure to follow this warning will result in serious injury or death to personnel. If you are burned, immediately seek medical attention.**

### NOTE

**Use rags as required to clean any fuel spills.**

### **a. REMOVAL**

1. Remove two flange bolts (1) from injection pump (2) and crankcase (7).
2. Aline control rack pin (3) with notch (5) in crankcase (7) and remove injection pump (2).

### NOTE

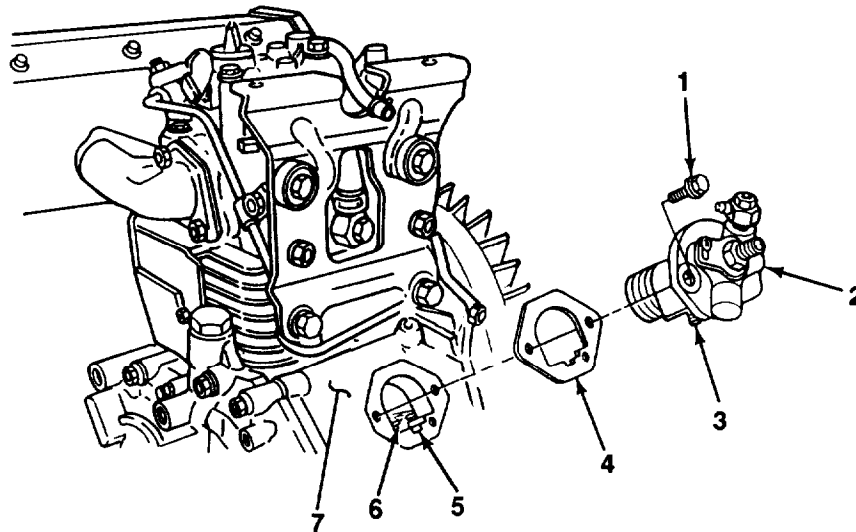
**Note quantity of shim(s) to aid during installation.**

3. Remove shim(s) (4) from crankcase (7).

---

**4-120. INJECTION PUMP REPLACEMENT (Con't).**


---


**b. CLEANING**


- Dry cleaning solvent, P-D-680, is toxic and flammable. Always wear protective goggles and gloves, and use only in a well-ventilated area. Avoid contact with skin, eyes, and clothes, and DO NOT breathe vapors. DO NOT use near open flame or excessive heat. The solvent's flash point is 100° F-138° F (38° C-59° C). If you become dizzy while using cleaning solvent, immediately get fresh air and medical help. If solvent contacts eyes, immediately wash your eyes and seek medical attention.

Clean injection pump mounting surface of crankcase with a rag dipped in dry cleaning solvent. Ensure that mounting surface is clean and dry.

**c. INSTALLATION**

1. Install shim(s) (4) on crankcase (7).
2. Position injection pump (2) at crankcase (7) with control rack pin (3) firmly inserted into groove of fork lever (6).
3. Install two flange bolts (1) to injection pump (2) and crankcase (7). Evenly torque flange bolts to 84-96 lb.-in. (9-11 N •m).
4. Check timing adjustment (see subparagraph d).

---

## 4-120. INJECTION PUMP REPLACEMENT (Con't).

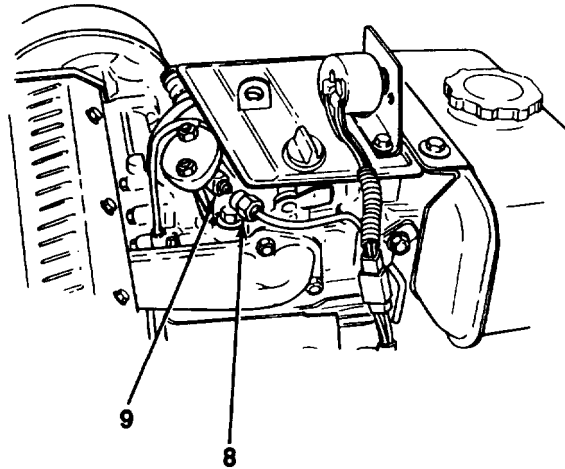
---

### d. TIMING ADJUSTMENT

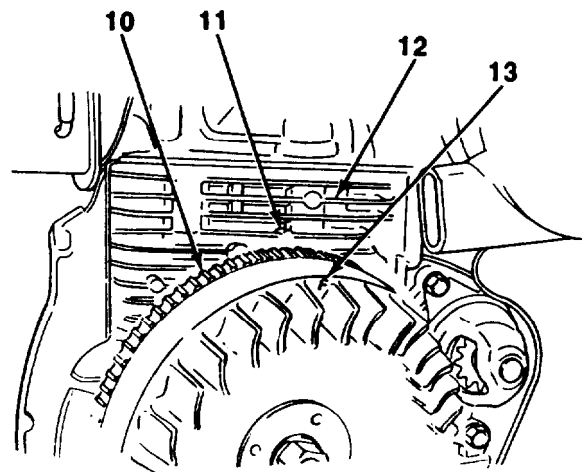
#### NOTE

Assistance is required to check timing.

1. Install injection pipe (8). Leave end at nozzle holder (9) disconnected (see paragraph 4-122).
2. Install fuel tank and fill (see paragraph 4-125).
3. Remove spiral case (see paragraph 4-128).
4. Set engine speed control lever to HIGH START (see paragraph 2-20).



5. Turn flywheel (10) clockwise to check for fuel leaking from tip of injection pipe (8).
6. Slowly turn flywheel (10) clockwise. Immediately stop when fuel flow at tip of injection pipe (8) increases.
7. Check timing marks on cylinder fins (12) and flywheel (10). Timing mark (11) on cylinderfins must be alined with timing mark F (13) on flywheel.





---

**4-120. INJECTION PUMP REPLACEMENT (Con't).**

---

**NOTE**

**Adding one shim will advance timing mark F on flywheel by approximately 1.0°-1.5°.**

8. If timing is not correct, adjust by adding or removing shims.
9. Connect injection pipe (8) to nozzle holder (9).
10. Install spiral case (see paragraph 4-128).
11. Set engine speed control lever to LOW (see paragraph 2-20).

**Follow-on Tasks:**

- Install engine (front dolly) (see paragraph 4-115).
- Connect negative (-) ground cable to battery (rear dolly) (see paragraph 4-45).
- Start engine (see paragraph 2-20) and check for fuel leaks.

---

## 4-121. NOZZLE HOLDER REPLACEMENT

---

*This Task Covers:*

- a. Removal b. Installation
- 

*Initial Setup:*

### Equipment Conditions:

- Negative (-) ground cable disconnected from battery (see paragraph 4-45).
- Oil cooler cover removed (see paragraph 4-117).

### Materials/Parts:

- Rags (Item 25, Appendix F)

### General Safety Instructions:

- DO NOT perform this procedure near fire, flames, or sparks.

### Tools/Test Equipment:

- General mechanic's tool kit (Item 30, Appendix G)
  - Stud remover and Inserter (Item 27, Appendix G)
  - Torque wrench, 0-200 lb.-in. (Item 41, Appendix G)
- 



**Diesel fuel is combustible. DO NOT smoke or allow an open flame near fuel tank. Shut down engine when adding fuel. Failure to follow this warning will result in serious injury or death to personnel. If you are burned, immediately seek medical attention.**

### NOTE

**Use rags as required to clean any fuel spills.**

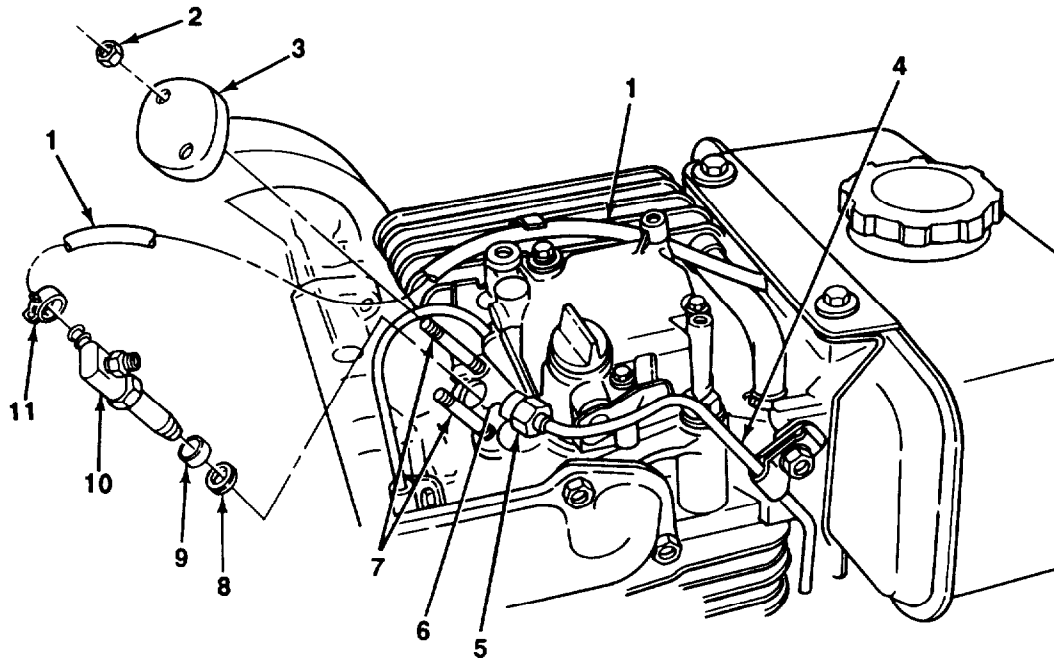
### **a. REMOVAL**

1. Loosen nut (5) and disconnect injection pipe (4) from nozzle holder (10).
2. Slide back clip (11) and disconnect overflow hose (1) from nozzle holder (10).
3. Remove two nuts (2) and nozzle retainer (3) from nozzle holder (10).
4. Remove nozzle holder (10), heat seal (9) (if present), and copper gasket (8) from cylinder head (6). Inspect copper gasket for damage. Replace only if damaged.
5. If damaged, remove two studs (7) from cylinder head (6).

---

**4-121. NOZZLE HOLDER REPLACEMENT (Con't).**


---


**b. INSTALLATION**

1. If removed, install two studs (7) on cylinder head (6).

**NOTE**

**Heat seal is required if OC60D1 engine nozzle holder is being replaced with an OC60E1 engine nozzle holder.**

2. Install copper gasket (8) heat seal (9) (if required), and nozzle holder (10) on cylinder head (6).
3. Install nozzle retainer (3) over nozzle holder (10) with two nuts (2). Evenly torque nuts to 120-156 lb.-in. (14-18 N•m).
4. Connect overflow hose (1) to nozzle holder (10) with clip (11).
5. Connect injection pipe (4) to nozzle holder (10) and tighten nut (5).

**Follow-on Tasks:**

- Connect negative (-) ground cable to battery (see paragraph 4-45).
- Start engine (see paragraph 2-20) and check for fuel leaks.
- Install oil cooler cover (see paragraph 4-117).

---

## 4-122. FUEL LINES REPLACEMENT

---

*This Task Covers:*

- a. Fuel Hose Replacement
  - b. Injection Pipe Replacement
  - c. Overflow Hose Replacement
- 

*Initial Setup:*

### Equipment Conditions:

- Negative (-) ground cable disconnected from battery (see paragraph 4-45).

### Materials/Parts:

- 1 Rags (Item 25, Appendix F)

### Tools/Test Equipment:

- General mechanic's tool kit (Item 30, Appendix G)

### General Safety Instructions:

- DO NOT perform this procedure near fire, flames, or sparks.
- 



**WARNING**

**Diesel fuel is combustible. DO NOT smoke or allow an open flame near fuel tank. Shut down engine when adding fuel. Failure to follow this warning will result in serious injury or death to personnel. If you are burned, immediately seek medical attention.**

**CAUTION**

**DO NOT allow dirt or dust to enter fuel tank. Damage to engine fuel system will result.**

### NOTE

**Use rags as required to clean any fuel spills.**

### **a. FUEL HOSE REPLACEMENT**

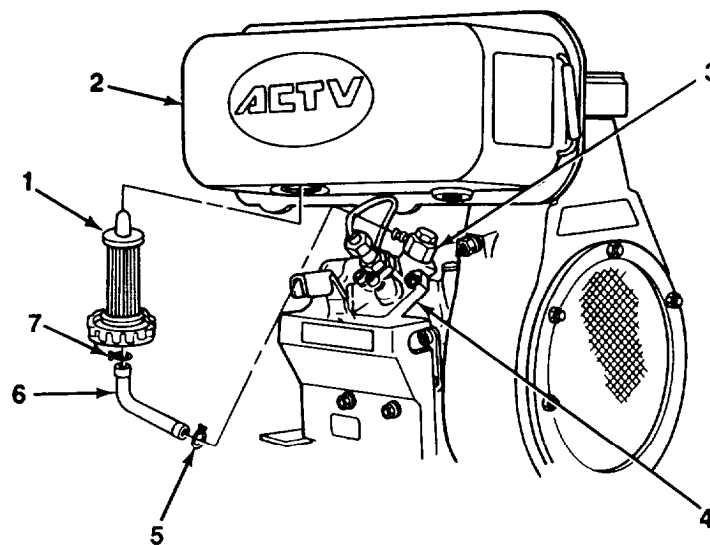
1. Drain fuel tank (see paragraph 4-125).
2. Slide back clip (5) and disconnect fuel hose (6) from joint (3) at injection pump (4).
3. Remove fuel filter (1) with fuel hose (6) from fuel tank (2).
4. Slide back clip (7) and remove fuel hose (6) from fuel filter (1).

---

**4-122. FUEL LINES REPLACEMENT (Con't).**

---

5. Install fuel hose (6) on fuel filter (1) with clip (7).
6. Install fuel filter (1) with fuel hose (6) on fuel tank (2).
7. Connect fuel hose (6) to joint (3) at injection pump (4) with clip (5).
8. Fill fuel tank (see paragraph 4-125).



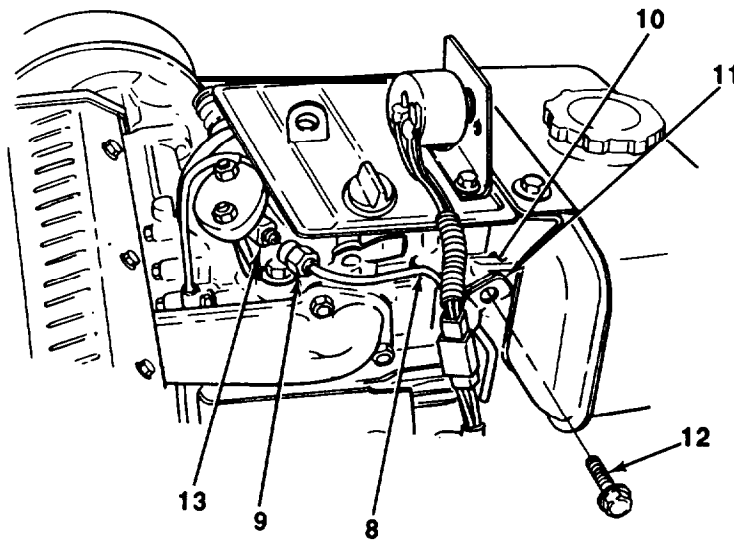
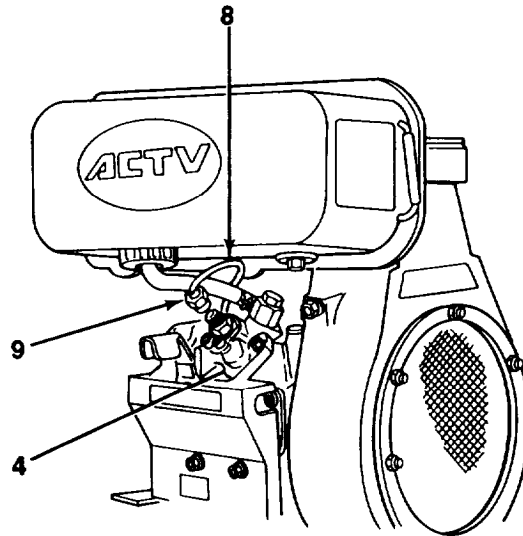
---

**4-122. FUEL LINES REPLACEMENT (Con't).**

---

**b. INJECTION PIPE REPLACEMENT**

1. Loosen two nuts (9) and disconnect injection pipe (8) from injection pump (4) and nozzle holder (13).
2. Remove flange bolt (12), clamp assembly (11) and injection pipe (8) from cylinder head (10).
3. Install injection pipe (8) on cylinder head (10) with clamp assembly (11) and flange bolt (12).
4. Connect injection pipe (8) to nozzle holder (13) and injection pump (4), and tighten two nuts (9).



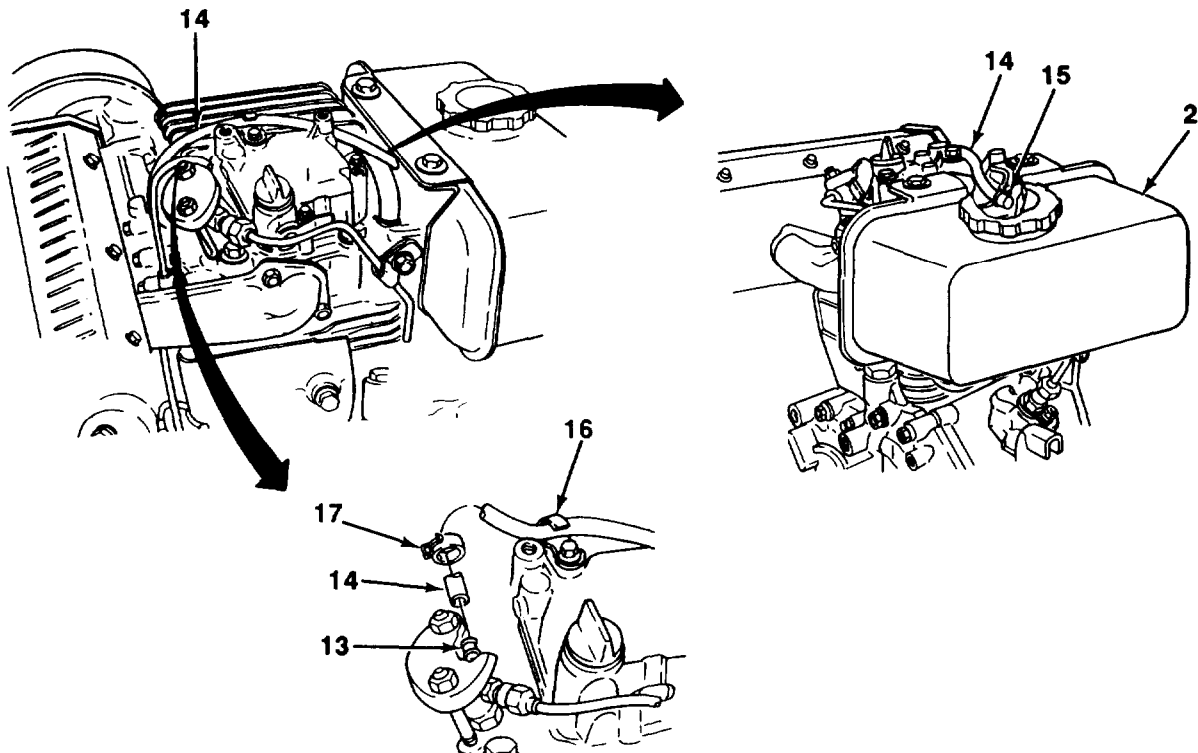
---

**4-122. FUEL LINES REPLACEMENT (Con't).**

---

**c. OVERFLOW HOSE REPLACEMENT**

1. Remove oil cooler cover (see paragraph 4-117).
2. Slide back clip (15) and disconnect overflow hose (14) from fuel tank (2).
3. Slide back clip (17) and disconnect overflow hose (14) from nozzle holder (13).
4. Unbend clamp (16) and remove overflow hose (14).

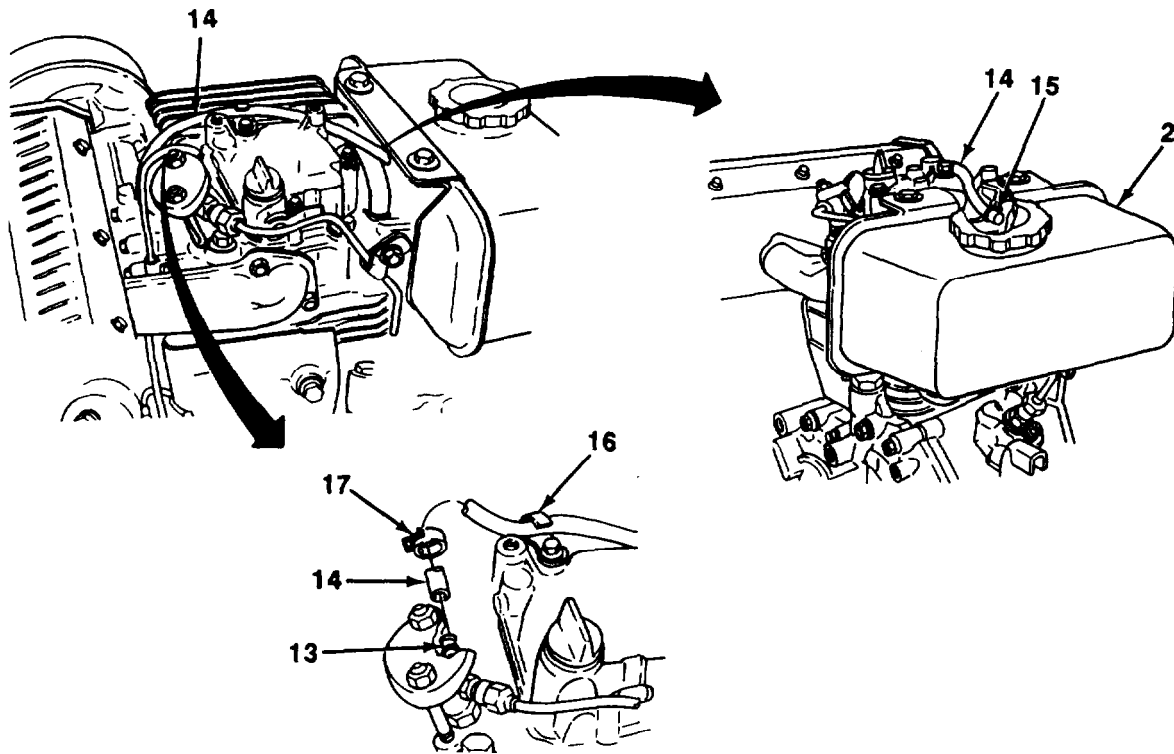


---

## 4-122. FUEL LINES REPLACEMENT (Con't).

---

5. Connect overflow hose (14) to nozzle holder (13) with clip (17).
6. Connect overflow hose (14) to fuel tank (2) with clip (15).
7. Secure overflow hose (15) with clamp (16).
8. Install oil cooler cover (see paragraph 4-117).



### **Follow-on Risks:**

- Connect negative (-) ground cable to battery (see paragraph 4-45).
- Start engine (see paragraph 2-20) and check for fuel leaks.



---

**4-123. AIR CLEANER MAINTENANCE.**

---

*This Task Covers:*

- |                        |                            |
|------------------------|----------------------------|
| a. Element Replacement | c. Cleaning and Inspection |
| b. Removal             |                            |
- 

*Initial Setup:*

**Equipment Conditions:**

- Engine starter switch set to OFF position (see paragraph 2-20).

**Tools/Test Equipment:**

- General mechanic's tool kit (Item 30, Appendix G)
- Compressor unit (Item 4, Appendix G)

**Materials/Parts:**

- Rags (Item 25, Appendix F)
- Dry cleaning solvent (Item 27, Appendix F)
- One element
- One gasket

**General Safety Instructions:**

- If NBC exposure is suspected, all air filter media must be handled by personnel wearing protective equipment.
  - Dry cleaning solvent is flammable and must not be used near an open flame. Use only in a well-ventilated area.
  - Compressed air used for cleaning purposes should never exceed 30 psi (207 kPa).
- 



**If NBC exposure is suspected, all engine air cleaner air filter media should be handled by personnel wearing protective equipment. Consult your NBC Officer or NBC NCO for appropriate handling or disposal procedures.**

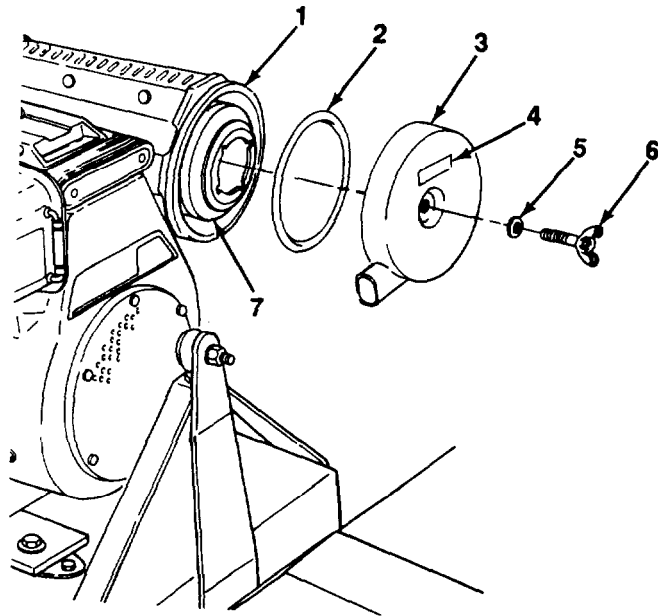
---

## 4-123. AIR CLEANER MAINTENANCE (Con't).

---

### a. ELEMENT REPLACEMENT

1. Remove any accumulated sand or dust from exterior of cover (3).
2. Remove wingbolt (6) and cover (3) from body (1).
3. If damaged, remove seal washer (5) and packing (2) from cover (3).
4. If damaged, remove label (4) (see paragraph 4-106).
5. Remove element (7) from body (1) and discard.



- **Dry cleaning solvent, P-D-660, is toxic and flammable. Always wear protective goggles and gloves, and use only in a well-ventilated area. Avoid contact with skin, eyes, and clothes, and DO NOT breathe vapors. DO NOT use near open flame or excessive heat. The solvent's flash point is 100° F-136° F (36° C-59° C). If you become dizzy while using cleaning solvent, immediately get fresh air and medical help. If solvent contacts eyes, immediately wash your eyes and seek medical attention.**

- **Compressed air used for cleaning or drying purposes, or for clearing restrictions, should never exceed 30 psi (207 kPa). Wear protective clothing (goggles/shield, gloves, etc.) and use caution to avoid injury to personnel.**

6. Clean body (1), cover (3), and wingbolt (6) with a clean rag. Use a rag dipped in dry cleaning solvent to remove stubborn dirt and grease. Dry thoroughly with compressed air.

---

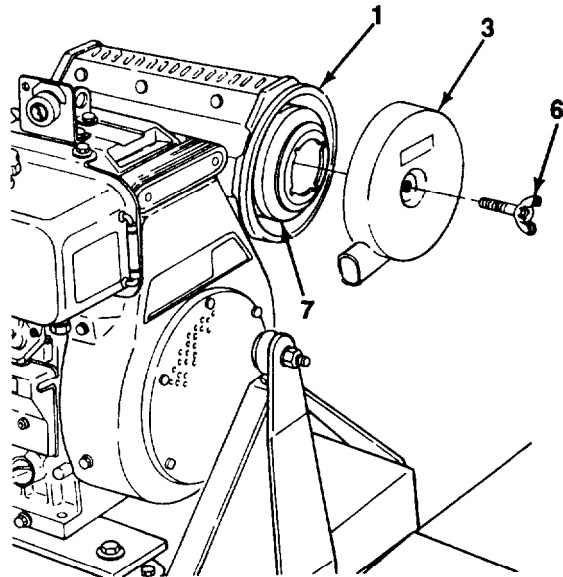
**4-123. AIR CLEANER MAINTENANCE (Con't).**


---

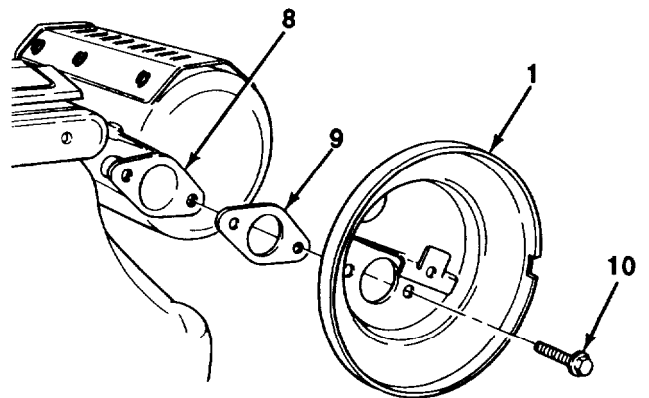
7. Install new element (7) in body (1).
8. If removed, install seal washer (5) and packing (2) on cover (3)
9. If removed, install label (4) (see paragraph 4-106).
10. Install cover (3) over element (7) with wingbolt (6). Tighten wingbolt fingertight.

**b. REMOVAL**

1. Remove wingbolt (6), cover (3), and element (7) from body (1).



2. Remove two flange bolts (10), body (1), and gasket (9) from air cleaner flange (8). Discard gasket.



---

## 4-123. AIR CLEANER MAINTENANCE (Con't).

---

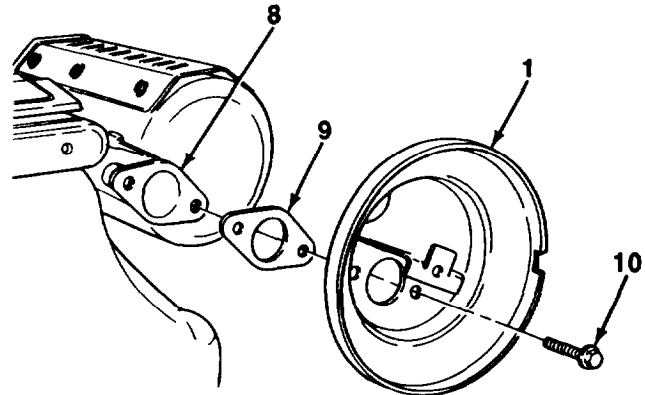
### c. CLEANING AND INSPECTION



- Dry cleaning solvent, P-D-680, is toxic and flammable. Always wear protective goggles and gloves, and use only in a well-ventilated area. Avoid contact with skin, eyes, and clothes, and DO NOT breathe vapors. DO NOT use near open flame or excessive heat. The solvent's flash point is 100° F-138° F (38°-59° C). If you become dizzy while using cleaning solvent, immediately get fresh air and medical help. If solvent contacts eyes, immediately wash your eyes and seek medical attention.
  - Compressed air used for cleaning or drying purposes, or for clearing restrictions, should never exceed 30 psi (207 kPa). Wear protective clothing (goggles/shield, gloves, etc.) and use caution to avoid injury to personnel.
1. Clean air cleaner flange with a rag dipped in dry cleaning solvent to remove all traces of gasket material. Dry mounting surface thoroughly with compressed air.
  2. Inspect all removed components for damage. Replace damaged components.

### d. INSTALLATION

1. Install new gasket (9) and body (1) on air cleaner flange (8) with two flange bolts (10).

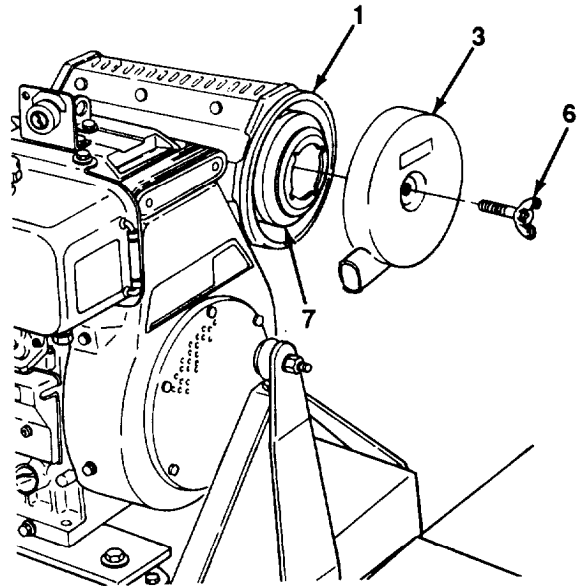


---

**4-123. AIR CLEANER MAINTENANCE (Con't).**

---

2. Install element (7) in body (1).
3. Install cover (3) over element (7) with wingbolt (6). Tighten wingbolt fingertight.



---

## 4-124. FUEL FILTER AND STRAINER REPLACEMENT.

---

*This Task Covers:*

- a. Removal
- b. Cleaning and Inspection
- c. Installation

---

*Initial Setup:*

### Equipment Conditions:

- Engine starter switch set to OFF position (see paragraph 2-20).

### Materials/Parts:

- Diesel fuel (Item 17 or Item 18, Appendix F)
- Rags (Item 25, Appendix F)
- Dry cleaning solvent (Item 27, Appendix F)

### Tools/Test Equipment:

- General mechanic's tool kit (Item 30, Appendix G)
- Compressor unit (Item 4, Appendix G)

### General Safety Instructions:

- DO NOT perform this procedure near fire, flames, or sparks.
- Dry cleaning solvent is flammable and must not be used near an open flame. Use only in a well-ventilated area.
- Compressed air used for cleaning purposes should never exceed 30 psi (267 kPa).



**WARNING**

**Diesel fuel is combustible. DO NOT smoke or allow an open flame near fuel tank. Shut down engine when adding fuel. Failure to follow this warning will result in serious injury or death to personnel. If you are burned, immediately seek medical attention.**

**CAUTION**

**DO NOT allow dirt or dust to enter fuel tank. Damage to engine will result.**

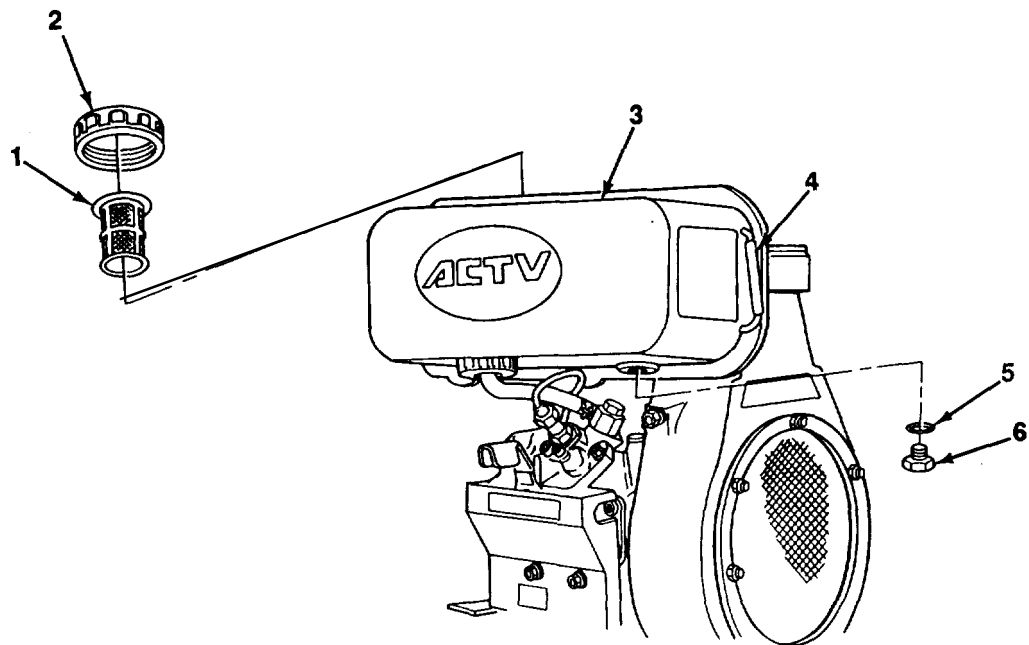
### NOTE

**A suitable container should be used to catch any draining fuel. Ensure that all spills are properly cleaned.**

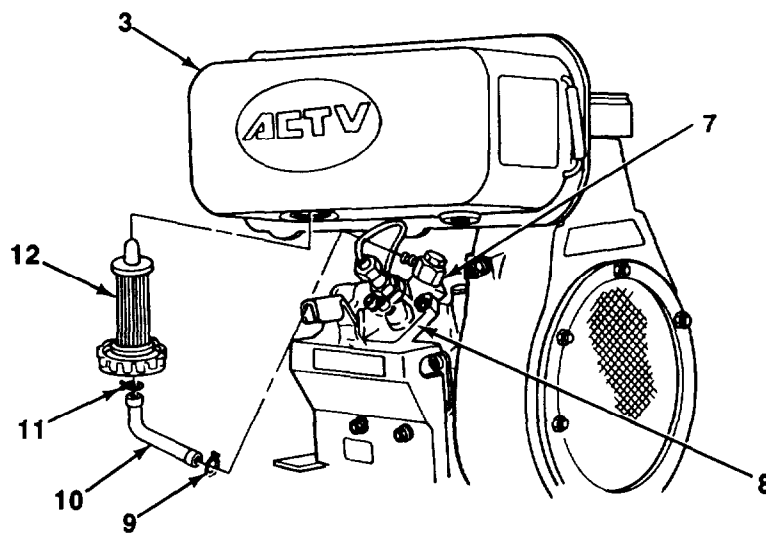
### **a. REMOVAL**

1. Remove cap (2), drain plug (6), and copper gasket (5) from fuel tank (3). Drain fuel into a suitable container.
2. Remove strainer (1) from fuel tank (3). Install cap (2) on fuel tank.

**4-124. FUEL FILTER AND STRAINER REPLACEMENT (Con't).**



3. Slide back clip (9) and disconnect fuel hose (10) from joint (7) at injection pump (8).
4. Remove fuel filter (12) with fuel hose (10) from fuel tank (3).
5. Slide back clip (11) and remove fuel hose (10) from fuel filter (12).



---

## 4-124. FUEL FILTER AND STRAINER REPLACEMENT (Con't).

---

### **b. CLEANING AND INSPECTION**



- **Dry cleaning solvent, P-D-680, is toxic and flammable. Always wear protective goggles and gloves, and use only in a well-ventilated area. Avoid contact with skin, eyes, and clothes, and DO NOT breathe vapors. DO NOT use near open flame or excessive heat. The solvent's flash point is 100° F-138° F (38° C-69° C). If you become dizzy while using cleaning solvent, immediately get fresh air and medical help. If solvent contacts eyes, immediately wash your eyes and seek medical attention.**
- **Compressed air used for cleaning or drying purposes, or for clearing restrictions, should never exceed 30 psi (207 kPa). Wear protective clothing (goggles/shield, gloves, etc.) and use caution to avoid injury to personnel.**

1. Clean strainer, drain plug, and copper gasket in dry cleaning solvent and dry with compressed air.

### **CAUTION**

**Handle fuel filter with care. Rough handling will cause damage.**

2. Clean fuel filter with compressed air.
3. Inspect strainer and fuel filter for breaks, holes, or tears. Replace damaged components.
4. Inspect drain plug for cracks, breaks, or damaged threads. Replace damaged drain plug.
5. Inspect copper gasket for damage. Replace damaged copper gasket.

### **c. INSTALLATION**

1. Install fuel hose (10) on fuel filter (12) with clip (11).
2. Install fuel fitter (12) with fuel hose (10) on fuel tank (3).
3. Connect fuel hose (10) to joint (7) at injection pump (8) with clip (9).
4. Install copper gasket (5) and drain plug (6) on fuel tank (3).
5. Remove cap (2) and install strainer (1) inside fuel tank (3).

### **NOTE**

- **Pivoting tray must be unlocked and level to ensure filling to correct level.**
  - **If fuel tank is filled too full, fuel may seep from vented cap.**
6. Fill fuel tank (3) with diesel fuel. Maximum fuel level height should be just visible at top of fuel indicator (4). DO NOT overfill.

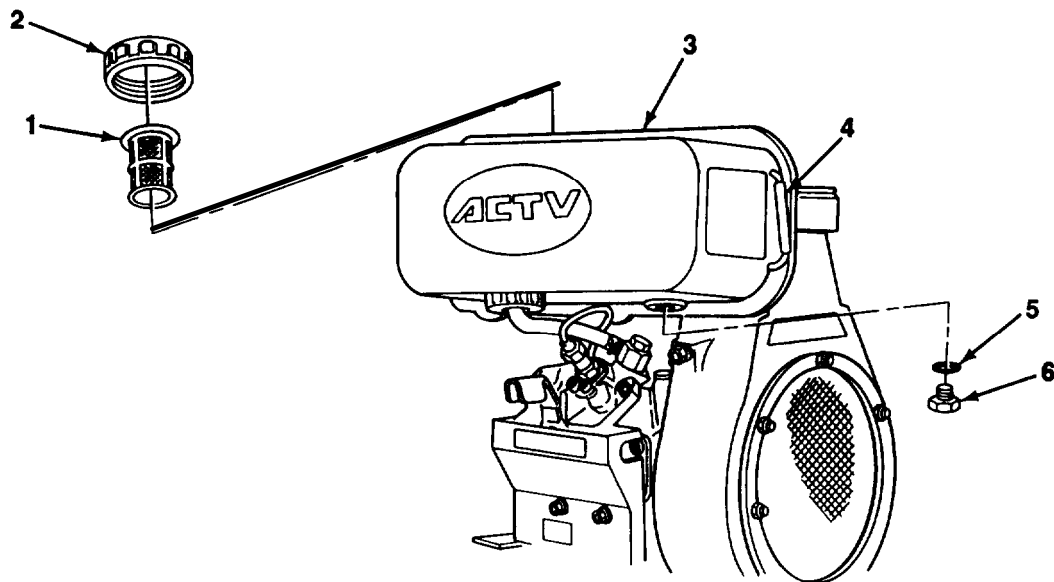
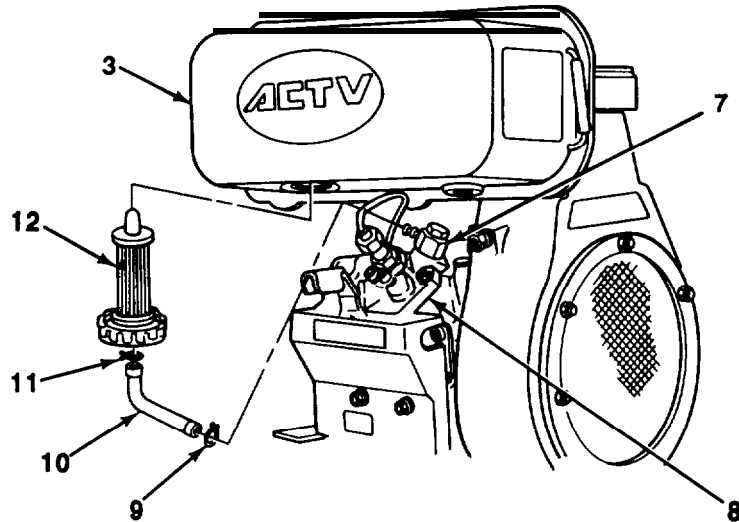


---

**4-124. FUEL FILTER AND STRAINER REPLACEMENT (Con't).**

---

7. Install cap (2) on fuel tank (3).



**Follow-on Tasks:**

- Start engine (see paragraph 2-20) and check for fuel leaks.

---

## 4-125. FUEL TANK MAINTENANCE.

---

*This Task Covers:*

- |                            |                 |
|----------------------------|-----------------|
| a. Draining                | e. Assembly     |
| b. Removal                 | f. Installation |
| c. Disassembly             | g. Filling      |
| d. Cleaning and Inspection |                 |
- 

*Initial Setup:*

### Equipment Conditions:

- Negative (-) ground cable disconnected from battery (see paragraph 4-45).

### Tools/Test Equipment:

- General mechanic's tool kit (Item 30, Appendix G)
- Compressor unit (Item 4, Appendix G)

### Materials/Parts:

- Diesel fuel (Item 17 or Item 18, Appendix F)
- Rags (Item 25, Appendix F)
- Dry cleaning solvent (Item 27, Appendix F)

### General Safety Instructions:

- DO NOT perform this procedure near fire, flames, or sparks.
  - Dry cleaning solvent is flammable and must not be used near an open flame. Use only in a well-ventilated area.
  - Compressed air used for cleaning purposes should never exceed 30 psi (207 kPa).
- 



**WARNING**

**Diesel fuel is combustible. DO NOT smoke or allow an open flame near fuel tank. Shut down engine when adding fuel. Failure to follow this warning will result in serious injury or death to personnel. If you are burned, immediately seek medical attention.**

**CAUTION**

**DO NOT allow dirt or dust to enter fuel tank. Damage to engine will result.**

**NOTE**

**Use rags as required to clean any fuel spills.**

### **a. DRAINING**

**NOTE**

- A suitable container should be used to catch any draining fuel. Ensure that all spills are properly cleaned.
- A small amount of fuel may remain in fuel tank.

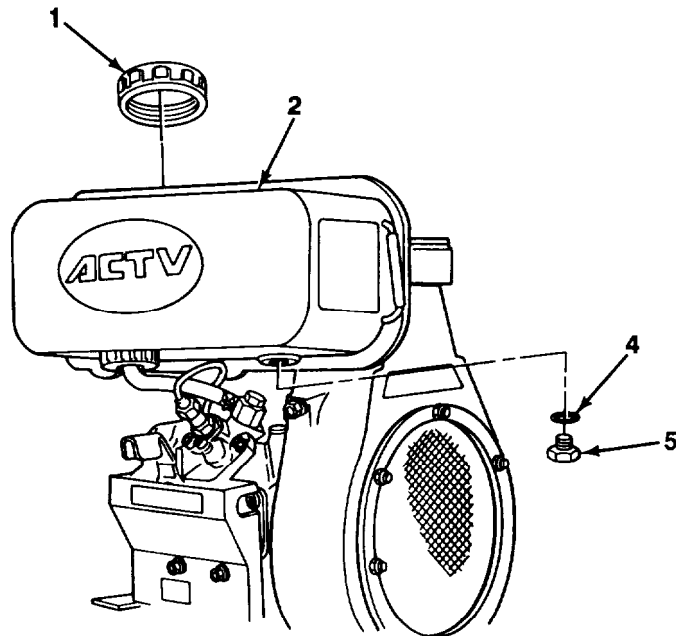
1. Remove cap (1) drain plug (5), and copper gasket (4) from fuel tank (2). Drain fuel into a suitable container.

---

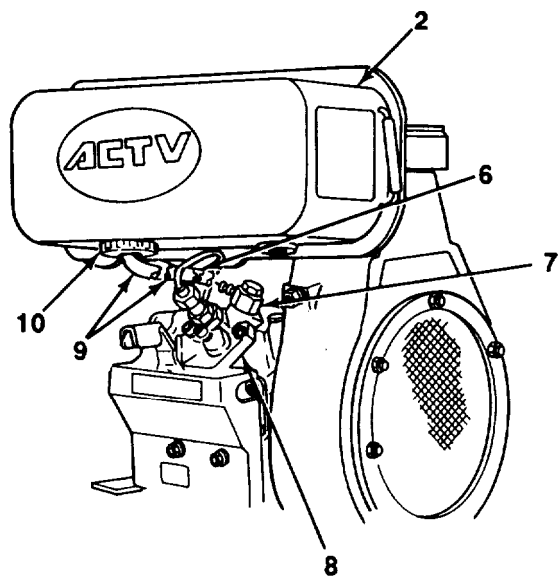
**4-125. FUEL TANK MAINTENANCE (Con't).**


---

2. Install cap (1) on fuel tank (2).


**b. REMOVAL**

1. Remove oil cooler cover to gain better access to remove fuel tank (2) (see paragraph 4-117).
2. Slide back clip (6) and disconnect fuel hose (9) from joint (7) at injection pump (8).
3. Remove fuel filter (10) with fuel hose (9) from fuel tank (2).

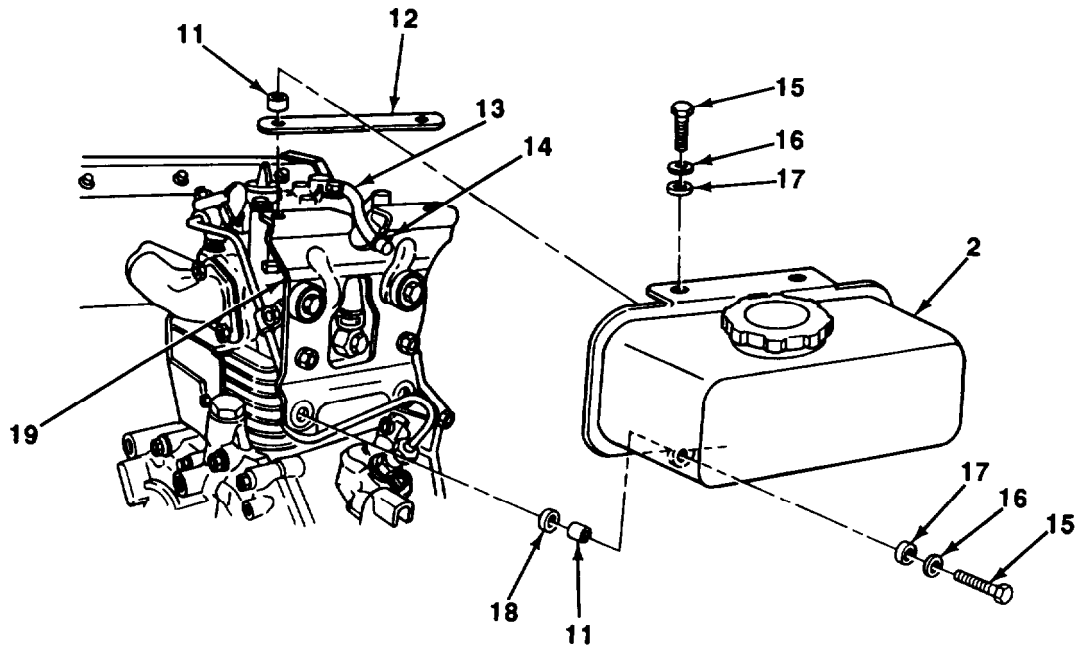


---

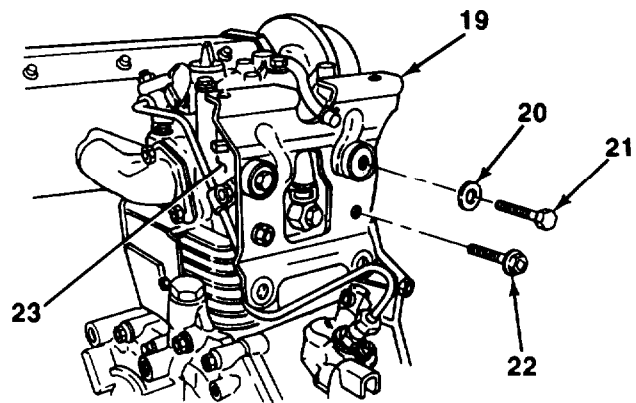
**4-125. FUEL TANK MAINTENANCE (Con't).**

---

4. Remove four bolts (15), washers (16), and cushions (17) from fuel tank (2).
5. Pull fuel tank (2) away from stay (19) to gain access to overflow hose (13). Slide back clip (14) and disconnect overflow hose from fuel tank.
6. Remove fuel tank (2), four collars (11), cushion (12), and two cushions (16) from stay (19).



7. If stay (19) is damaged, remove two flange bolts (22) from stay and cylinder head (23). Remove two bolts (21), washers (20), and stay from cylinder head.



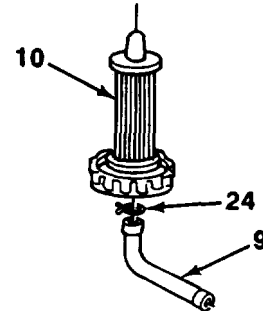
---

**4-125. FUEL TANK MAINTENANCE (Con't).**

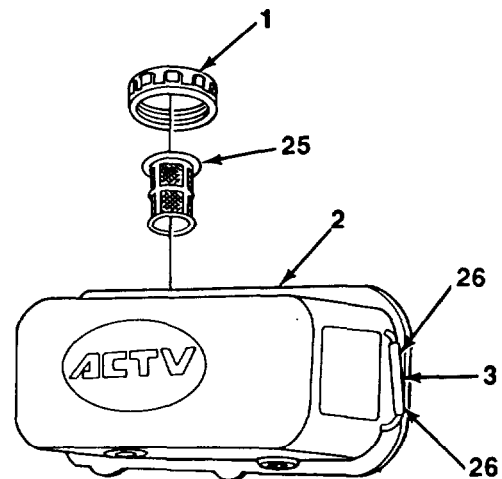
---

**c. DISASSEMBLY**

1. Slide back clip (24) and remove fuel hose (9) from fuel filter (10).



2. Remove cap (1) and strainer (25) from fuel tank (2).
3. Slide back two clips (26) and remove fuel indicator (3) from fuel tank (2).



---

**4-125. FUEL TANK MAINTENANCE (Con't).**

---

**CLEANING AND INSPECTION**



- **Dry cleaning solvent, P-D-680, is toxic and flammable. Always wear protective goggles and gloves, and use only in a well-ventilated area. Avoid contact with skin, eyes, and clothes, and DO NOT breathe vapors. DO NOT use near open flame or excessive heat. The solvent's flash point is 100° F-138° F (38° C-59° C). If you become dizzy while using cleaning solvent, immediately get fresh air and medical help. If solvent contacts eyes, immediately wash your eyes and seek medical attention.**
- **Compressed air used for cleaning or drying purposes, or for clearing restrictions, should never exceed 30 psi (207 kPa). Wear protective clothing (goggles/shield, gloves, etc.) and use caution to avoid injury to personnel.**

1. Clean all removed metal components in dry cleaning solvent and dry with compressed air.

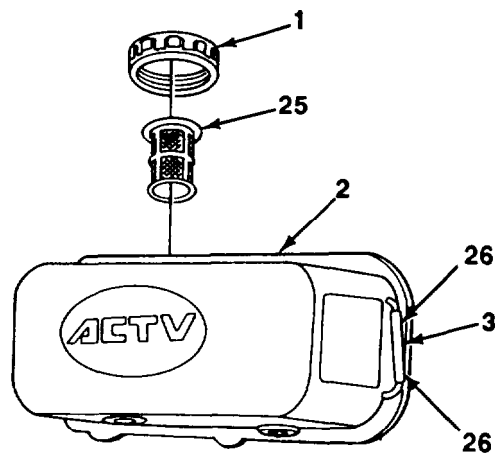
**CAUTION**

**Handle fuel filter with care. Rough handling will cause damage.**

2. Clean fuel filter with compressed air.
3. Inspect all removed components for cracks, breaks, holes, tears, or damaged threads. Replace damaged components.
4. Inspect fuel tank for missing or illegible labels. Replace damaged labels (see paragraph 4-106).

**e. ASSEMBLY**

1. Install fuel indicator (3) on fuel tank (2) with two clips (26).
2. Install strainer (25) and cap (1) on fuel tank (2).

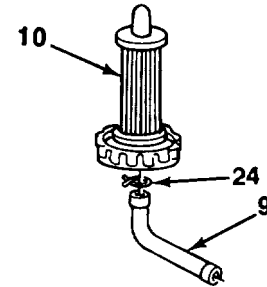


---

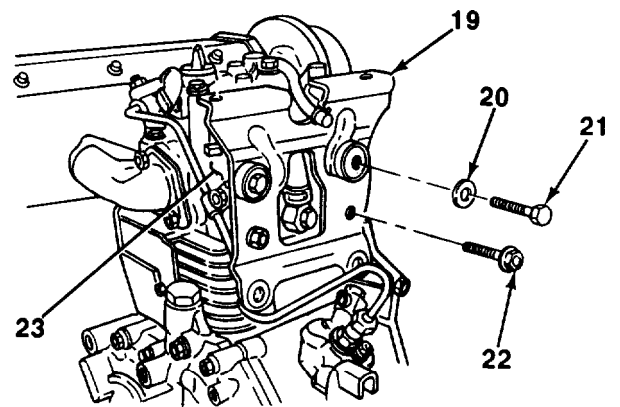
**4-125. FUEL TANK MAINTENANCE (Con't).**

---

3. Install fuel hose (9) on fuel filter (10) with clip (24).

**f. INSTALLATION**

1. If removed, install stay (19) on cylinder head (23) with two washers (20), bolts (21), and flange bolts (22).

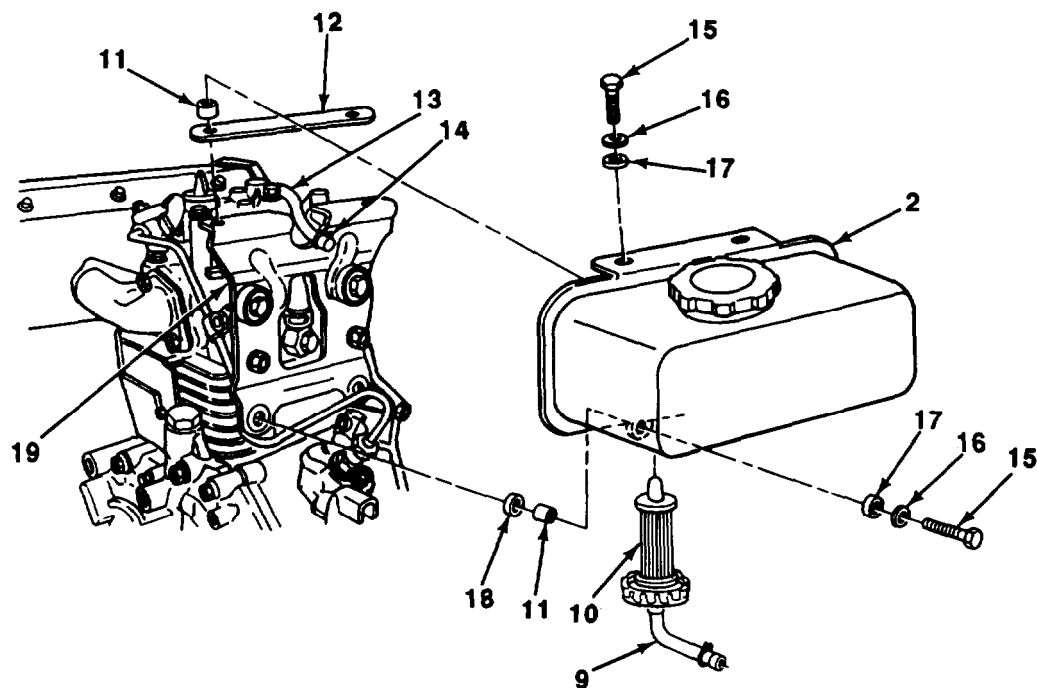


---

#### 4-125. FUEL TANK MAINTENANCE (Con't).

---

2. Install fuel filter (10) with fuel hose (9) on fuel tank (2).
3. Position fuel tank (2) for installation and connect overflow hose (13) to fuel tank with clip (14).
4. Position cushion (12), two cushions (16), and four collars (11) at stay (19).
5. Install fuel tank (2) on cushion (12) and stay (19) with four cushions (17), washers (16), and bolts (15).



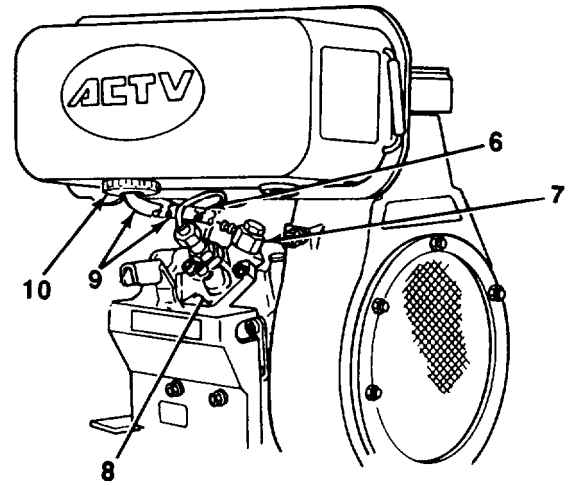


---

**4-125. FUEL TANK MAINTENANCE (Con't).**


---

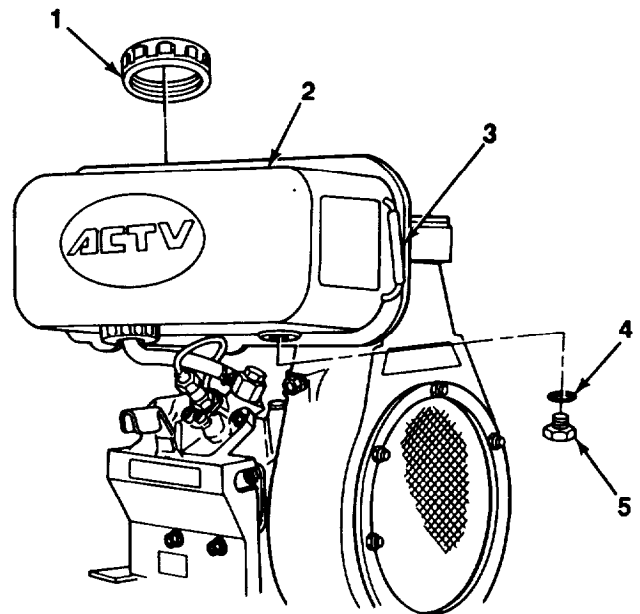
6. Connect fuel hose (9) to joint (7) at fuel injection pump (6) with clip (6).
7. Install oil cooler cover (see paragraph 4-117).


**g. FILLING**

1. Install copper gasket (4) and drain plug (5) on fuel tank (2).

**NOTE**

- **Pivoting tray must be unlocked and level to ensure filling to correct level.**
  - **If tank is filled too full, fuel may seep from vented cap.**
2. Remove cap (1) and fill fuel tank (2) with diesel fuel. Maximum fuel level height should be just visible at top of fuel indicator (3). DO NOT overfill.
  3. Install cap (1) on fuel tank (2).


**Follow-on Tasks:**

- Connect negative (-) ground cable to battery (see paragraph 4-45).
- Start engine (see paragraph 2-20) and check for fuel leaks.

---

## 4-126. SIDE COVER REPLACEMENT.

---

*This Task Covers:*

a. Removal

b. Installation

---

*Initial Setup:*

### Tools/Test Equipment:

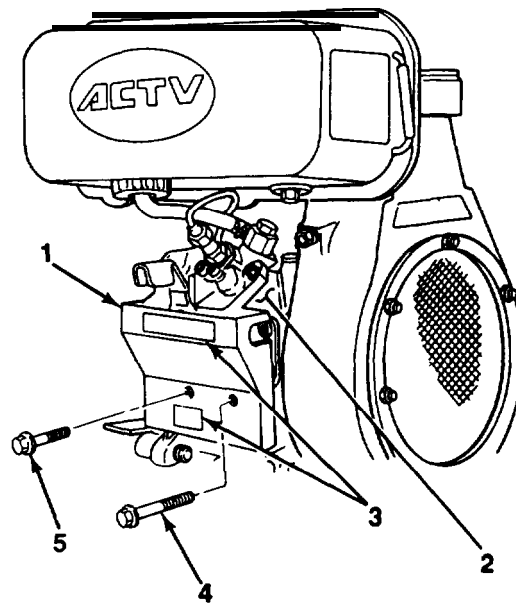
- General mechanic's tool kit (Item 30, Appendix G)
  - Torque wrench, 0-175 lb.-ft. (Item 42, Appendix G)
- 

#### **a. REMOVAL**

Remove two flange bolts (4 and 5) and side cover (1) from crankcase (2).

#### **b. INSTALLATION**

1. If labels (3) on side cover (1) are missing or illegible, replace labels (see paragraph 4-106).
2. Install side cover (1) on crankcase (2) with two flange bolts (4 and 5). Torque flange bolts to 17-20 lb.-ft. (23-27 N·m).



---

## 4-127. MUFFLER REPLACEMENT

---

*This Task Covers:*

- |                            |                 |
|----------------------------|-----------------|
| a. Removal                 | c. Installation |
| b. Cleaning and Inspection |                 |
- 

*Initial Setup:*

### **Equipment Conditions:**

- Engine starter switch set to OFF position (see paragraph 2-20).
- Spring supporting hydraulic hose assemblies inside abrasion sleeve (hose bundle) removed from lanyard tab at muffler cover (see paragraph 4-109).

### **Tools/Test Equipment:**

- General mechanic's tool kit (Item 30, Appendix G)
- Stud remover and inserter (Item 27, Appendix G)
- Torque wrench, 0-175 lb.-ft. (Item 42, Appendix G)

### **Materials/Parts:**

- Rags (Item 25, Appendix F)
- Dry cleaning solvent (Item 27, Appendix F)
- One gasket

### **General Safety Instructions:**

- Allow exhaust system to cool before attempting to service.
  - DO NOT use a dry brush or compressed air to clean area of engine muffler gasket.
  - Dry cleaning solvent is flammable and must not be used near an open flame. Use only in a well-ventilated area.
- 

**WARNING**

**Before attempting to replace any part of exhaust system, allow exhaust system to cool. Failure to follow this warning will result in serious burns.**

---

## 4-127. MUFFLER REPLACEMENT (Con't).

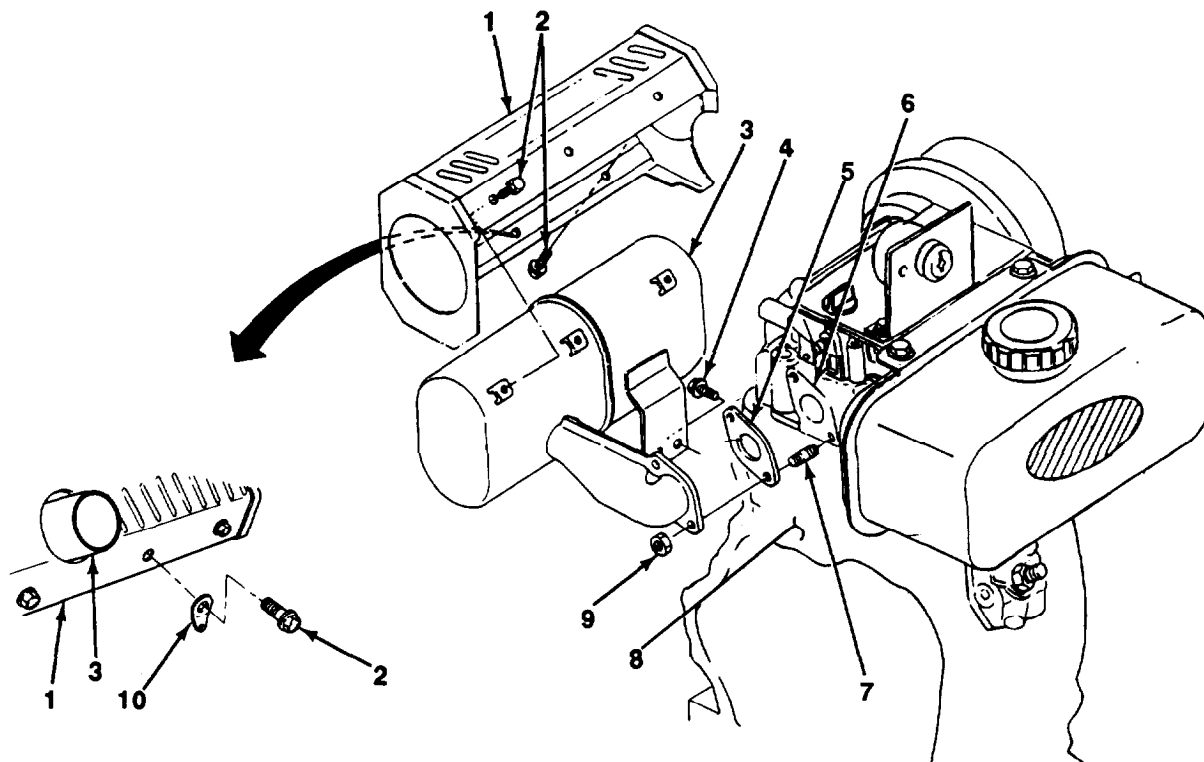
---

**a. REMOVAL**

**NOTE**

**Bottom middle flange bolt also secures lanyard tab that is part of hydraulic hose bundle support at muffler cover.**

1. Remove six flange bolts (2), lanyard tab (10), and muffler cover (1) from muffler (3).
2. Remove two nuts (9) from studs (7).
3. Remove two flange bolts (4) from muffler (3) and crankcase (8).
4. Remove muffler (3) and gasket (5) from cylinder head (6). Discard gasket.
5. If damaged, remove two studs (7) from cylinder head (6).



---

## 4-127. MUFFLER REPLACEMENT (Con't).

---

### b. CLEANING AND INSPECTION



- **DO NOT** handle components in area of engine muffler gasket unless area has been properly cleaned. There may be asbestos dust on these components which can be dangerous if you touch it or breathe it. Wear an approved filter mask and gloves. Never use compressed air or a dry brush to clean components contaminated by asbestos. Dust may be removed using an industrial-type vacuum cleaner. Clean dust or mud away from components with water and a wet, soft brush or cloth. Failure to follow this warning may result in serious illness or death to personnel.
  - **Dry cleaning solvent, P-D-680, is toxic and flammable. Always wear protective goggles and gloves, and use only in a well-ventilated area. Avoid contact with skin, eyes, and clothes, and DO NOT breathe vapors. DO NOT use near open flame or excessive heat. The solvent's flash points 100° F-138° F (38° C-59° C). If you become dizzy while using cleaning solvent, immediately get fresh air and medical help. If solvent contacts eyes, immediately wash your eyes and seek medical attention.**
1. Clean all removed components with dry cleaning solvent and dry with a clean rag. Ensure that muffler gasket mounting surface on cylinder head is clean.
  2. Inspect all removed components for cracks, breaks, holes, distortion, damaged threads, or other damage. Replace damaged components.

### c. INSTALLATION

1. If removed, install two studs (7) on cylinder head (6).
2. Install new gasket (5) and muffler (3) on cylinder head (6).
3. Install two flange bolts (4) on muffler (3) and crankcase (8).
4. Install two nuts (9) on studs (7). Torque nuts to 17-20 lb.-ft. (23-27 N·m).

#### NOTE

**Bottom middle flange bolt at muffler cover also secures lanyard tab that is part of hydraulic hose bundle support.**

5. Install muffler cover (1) and lanyard tab (10) on muffler (3) with six flange bolts (2).

#### **Follow-on Tasks:**

- Install spring supporting hydraulic hose assemblies inside abrasion sleeve (hose bundle) to lanyard tab at muffler cover (see paragraph 4-109).

---

## 4-128. CYLINDER COWLING AND SPIRAL CASE REPLACEMENT

---

*This Task Covers:*

- a. Removal b. Installation
- 

*Initial Setup:*

**Equipment Conditions:**

- Engine starter switch set to OFF position, if removing cylinder cowling or spiral case on rear dolly engine (see paragraph 2-20).
- Engine removed, if removing spiral case on front dolly (see paragraph 4-115).

**Tools/Test Equipment:**

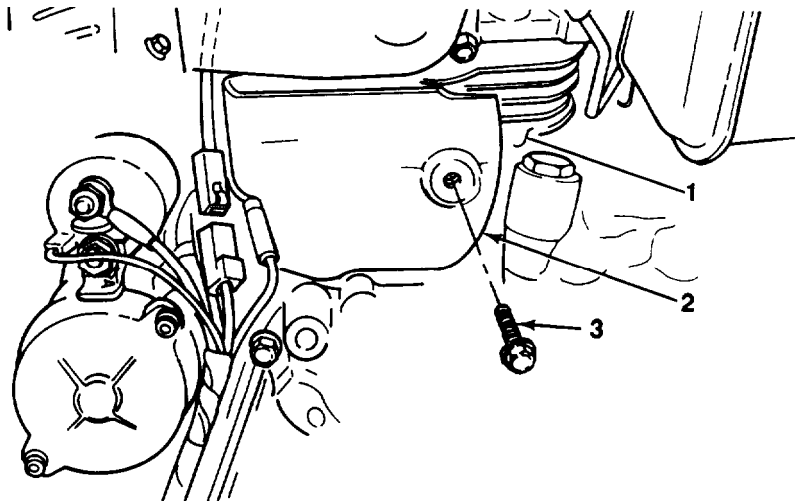
- General mechanic's tool kit (Item 30, Appendix G)
- 

**a. REMOVAL**

**NOTE**

- Perform step 1 if only removing cylinder cowling.
- Perform steps 2 and 3 if only removing spiral case.

1. Remove flange bolt (3) and cylinder cowling (2) from crankcase (1).

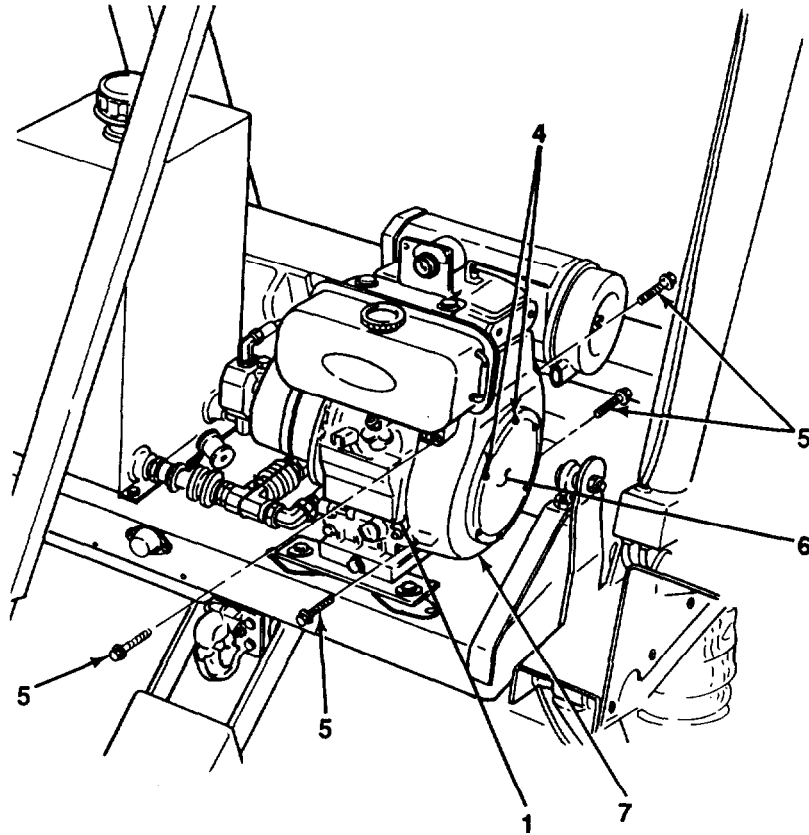


---

**4-128. CYLINDER COWLING AND SPIRAL CASE REPLACEMENT (Con't).**


---

2. Remove four flange bolts (5) and spiral case (7) from crankcase (1).
3. Remove six flange bolts (4) and dust cover (6) from spiral case (7).


**b. INSTALLATION**
**NOTE**

- Perform steps 1 and 2 if installing spiral case.
- Perform step 3 if installing cylinder cowling.

1. Install dust cover (6) on spiral case (7) with six flange bolts (4).
2. Position spiral case (7) at crankcase (1) and install four flange bolts (5).
3. Install cylinder cowling (2) on crankcase (1) with flange bolt (3).

**Follow-on Tasks:**

- Install engine (see paragraph 4-115).

---

## 4-129. REGULATOR REPLACEMENT.

---

*This Task Covers:*

a. Removal

b. Installation

---

*Initial Setup:*

### Equipment Conditions:

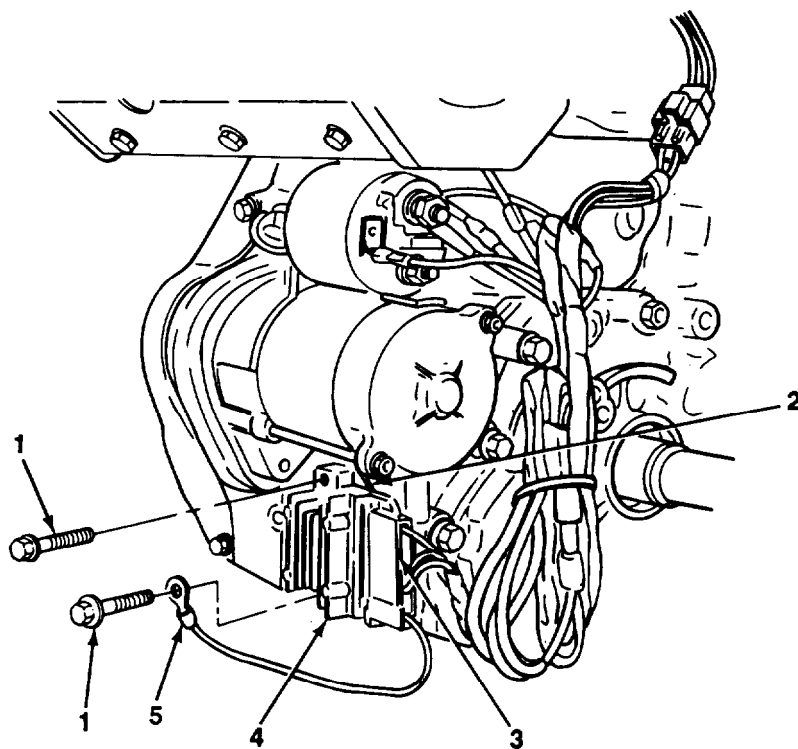
- Negative (-) ground cable disconnected from battery (see paragraph 4-45).

### Tools/Test Equipment:

- General mechanic's tool kit (Item 30, Appendix G)
- 

### a. REMOVAL

1. Disconnect wiring harness connector (3) from regulator (4).
2. Remove two flange bolts (1), wiring harness ground wire (5), and regulator (4) from stay (2).



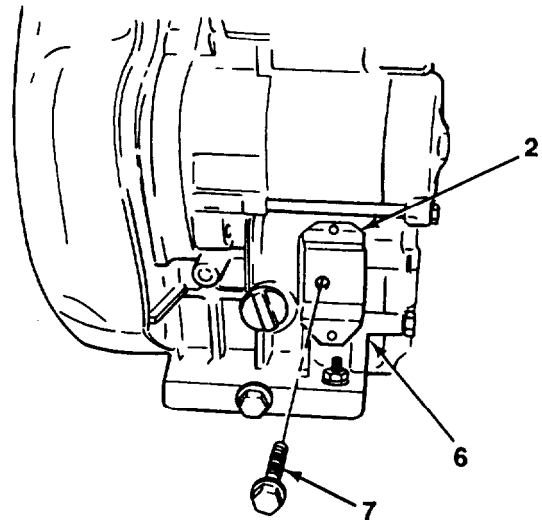


---

**4-129. REGULATOR REPLACEMENT (Con't).**

---

3. If damaged, remove flange bolt (7) and stay (2) from crankcase (6).

**b. INSTALLATION**

1. If removed, install stay (2) on crankcase (6) with flange bolt (7).
2. Install regulator (4), wiring harness ground wire (5), and two flange bolts (1) on stay (2).
3. Connect wiring harness connector (3) to regulator (4).

**Follow-on Tasks:**

- Connect negative (-) ground cable to battery (see paragraph 4-45).

---

## 4-130. STARTER REPLACEMENT.

---

*This Task Covers:*

- a. Removal b. Installation
- 

*Initial Setup:*

**Equipment Conditions:**

- Negative (-) ground cable disconnected from battery (rear dolly) (see paragraph 445).
- Engine removed (front dolly) (see paragraph 4-115).
- Spiral case removed (see paragraph 4-128).

**Materials/Parts:**

- Marker tags (Item 28, Appendix F)
- One springwasher

**Tools/Test Equipment:**

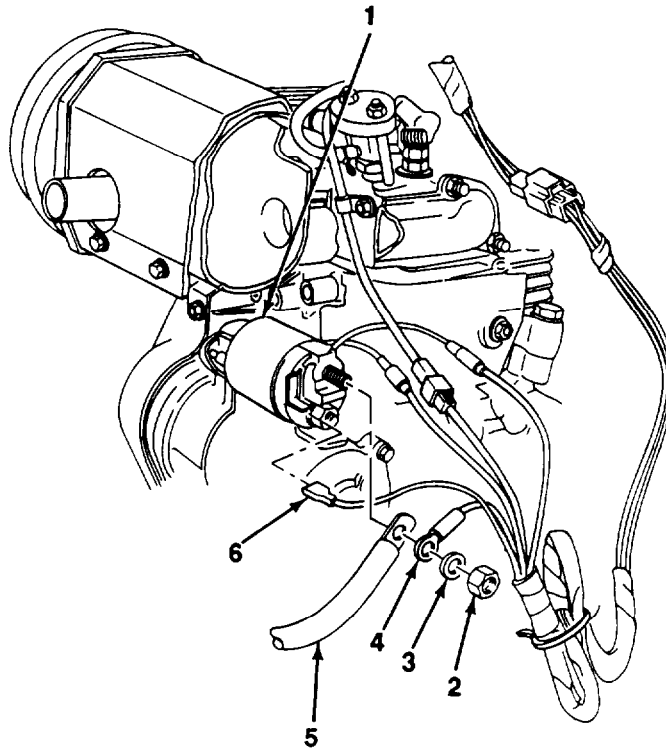
- General mechanic's tool kit (Item 30, Appendix G)
- 

**NOTE**

**All wires should be tagged before removal. Refer to paragraph 4-18 for tagging Instructions.**

**a. REMOVAL**

1. Remove nut (2), springwasher (3), wiring harness red wire (4), and positive (+) battery cable (5) from starter (1). Discard springwasher.
2. Disconnect wiring harness connector (6) from starter (1).

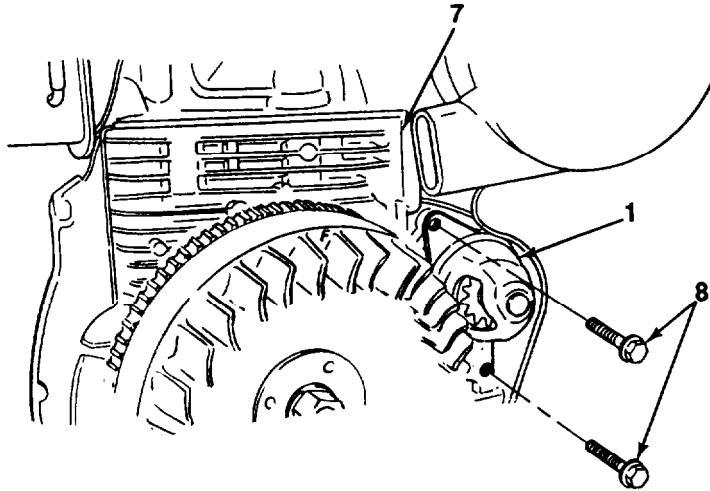


---

### 4-130. STARTER REPLACEMENT (Con't).

---

3. Remove two flange bolts (8) and starter (1) from crankcase (7).



#### **b. INSTALLATION**

1. Install starter (1) on crankcase (7) with two flange bolts (8).
2. Connect wiring harness connector (6) to starter (1).
3. Install positive (+) battery cable (5) and wiring harness red wire (4) on starter (1) with new springwasher (3) and nut (2).

#### **Follow-on Tasks:**

- Install spiral case (see paragraph 4-128).
- Install engine (front dolly) (see paragraph 4-115).
- Connect negative (-) ground cable to battery (rear dolly) (see paragraph 445).
- Start engine (see paragraph 2-20) to check operation of starter.

---

## 4-131. STARTER SWITCH ASSEMBLY REPLACEMENT.

---

*This Task Covers:*

- a. Removal b. Installation
- 

*Initial Setup:*

**Equipment Conditions:**

- Negative (-) ground cable disconnected from battery (see paragraph 445).

**Materials/Parts:**

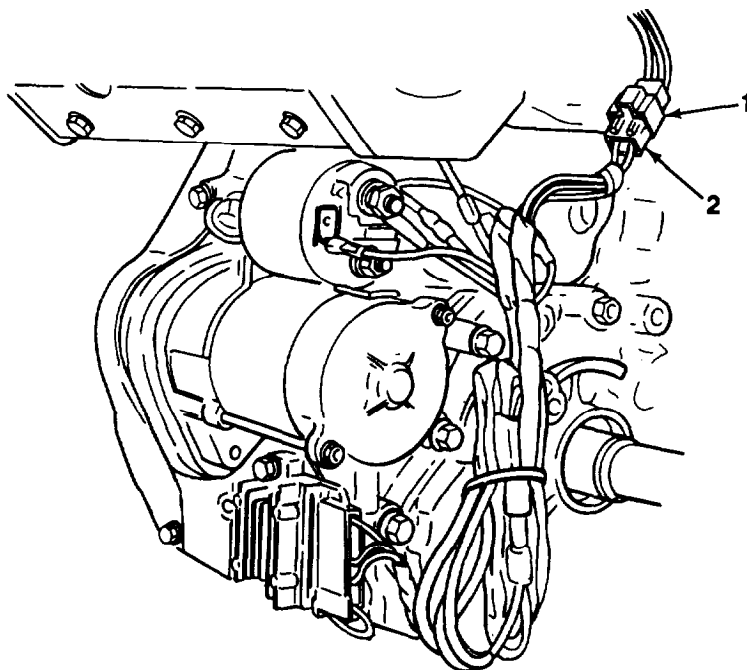
- One tie-down strap

**Tools/Test Equipment:**

- General mechanic's tool kit (Item 30, Appendix G)
- 

**a. REMOVAL**

1. Cut tie-down strap and disconnect wiring harness connector (2) from starter switch connector (1). Discard tie-down strap.

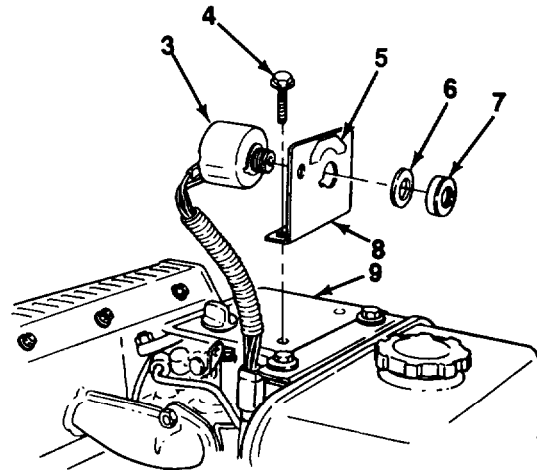


---

**4-131. STARTER SWITCH ASSEMBLY REPLACEMENT (Con't).**


---

2. Remove round nut (7), spacer (6) and starter switch (3) from case (8).
3. Remove two flange bolts (4) and case (8) from oil cooler cover (9).


**b. INSTALLATION**

1. If label (5) on case (8) is missing or illegible, replace label (see paragraph 4-106).
2. Install case (8) on oil cooler cover (9) with two flange bolts (4).
3. Install starter switch (3) on case (8) with key indexed to notch in case.
4. Install spacer (6) and round nut (7) on starter switch (3).
5. Connect wiring harness connector (2) to starter switch connector (1). Install new tie-down strap.

**Follow-on Tasks:**

- Connect negative (-) ground cable to battery (see paragraph 445).
- Start engine (see paragraph 2-20) and check operation of engine.

---

## 4-132. ENGINE WIRING HARNESS REPLACEMENT.

---

*This Task Covers:*

- a. Removal b. Installation
- 

*Initial Setup:*

### Equipment Conditions:

- Negative (-) ground cable disconnected from battery (see paragraph 4-45).

### Materials/Parts:

- Marker tags (Item 28, Appendix F)
- One springwasher
- One tie-down strap

### Tools/Test Equipment:

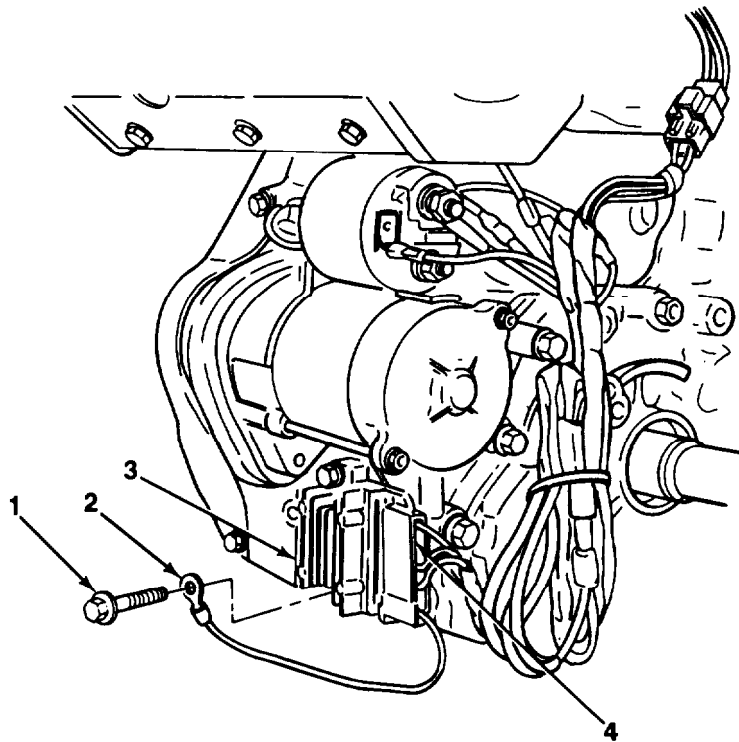
- General mechanic's tool kit (Item 30, Appendix G)
- 

### NOTE

- Refer to engine wiring diagram for assistance (see paragraph 4-135).
- All wires should be tagged before removal. Refer to paragraph 4-18 for tagging instructions.

### a. REMOVAL

1. Disconnect wiring harness connector (4) from regulator (3).
2. Remove flange bolt (1) and wiring harness ground wire (2) from regulator (3).

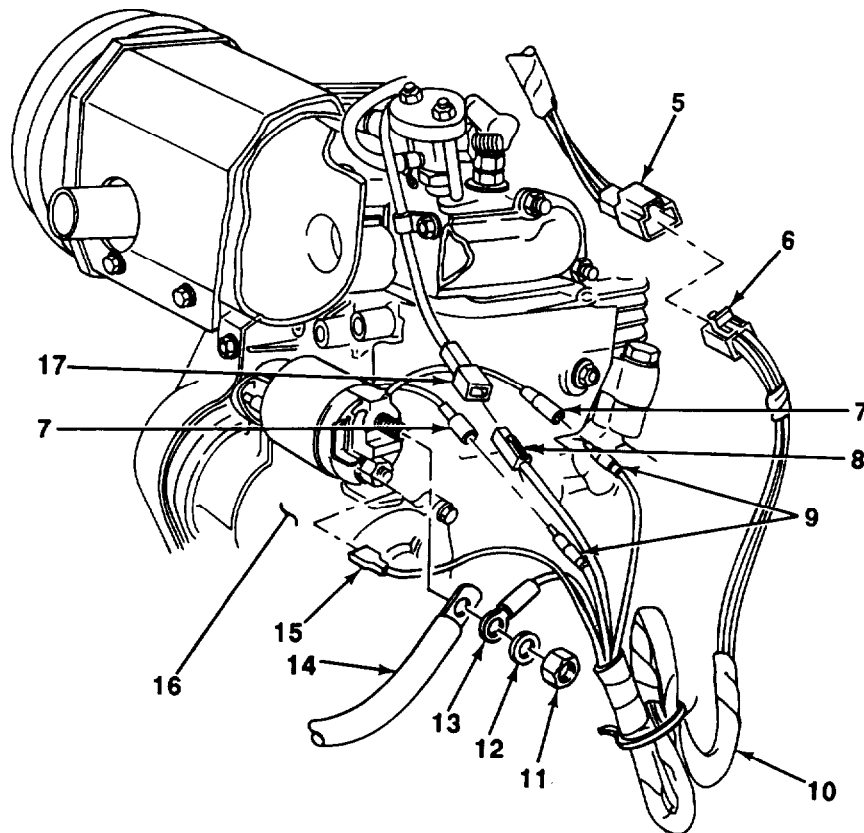


---

**4-132. ENGINE WIRING HARNESS REPLACEMENT (Con't).**

---

3. Cut tie-down strap and disconnect wiring harness connector (6) from starter switch connector (5).
4. Disconnect wiring harness connector (8) from glow plug cord connector (17).
5. Remove nut (11), springwasher (12) wiring harness red wire (13) and positive (+) battery cable (14) from starter (16). Discard springwasher.
6. Disconnect wiring harness connector (15) from starter (16).
7. Disconnect two wiring harness connectors (9) from stator assembly connectors (7).
8. Remove engine wiring harness (10).



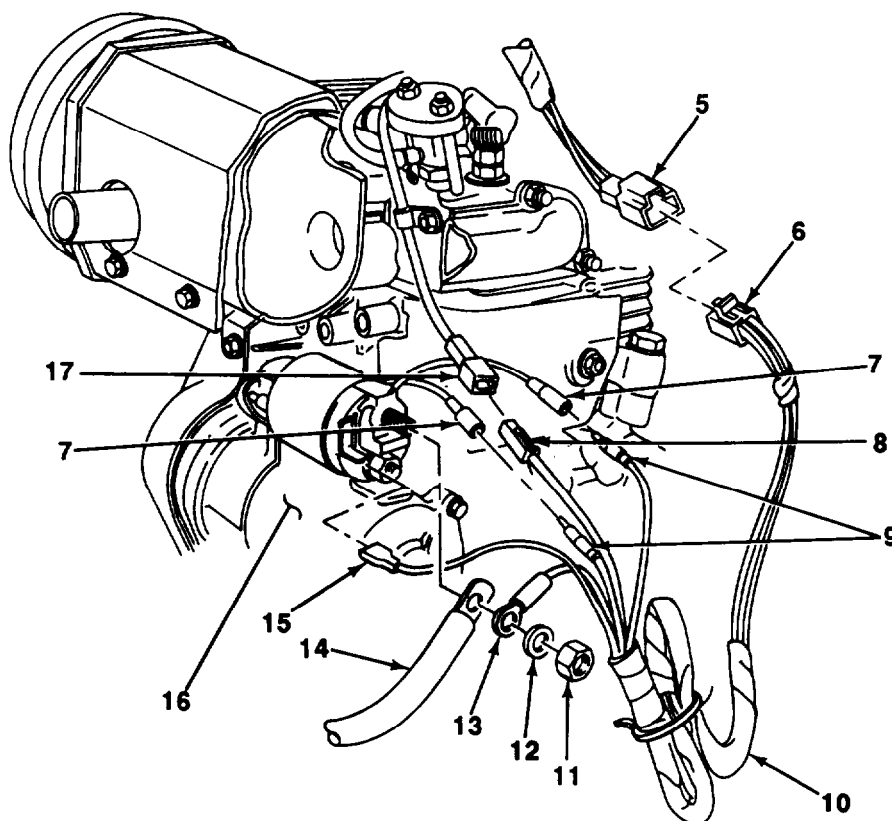
---

## 4-132. ENGINE WIRING HARNESS REPLACEMENT (Con't).

---

### **b. INSTALLATION**

1. Position engine wiring harness (10) for installation.
2. Connect two wiring harness connectors (9) to stator assembly connectors (7).
3. Connect wiring harness connector (15) to starter (16).
4. Install positive (+) battery cable (14) and wiring harness red wire (13) to starter (16) with new springwasher (12) and nut (11).
5. Connect wiring harness connector (8) to glow plug cord connector (17).
6. Connect wiring harness connector (6) to starter switch connector (5). Install new tie-down strap.



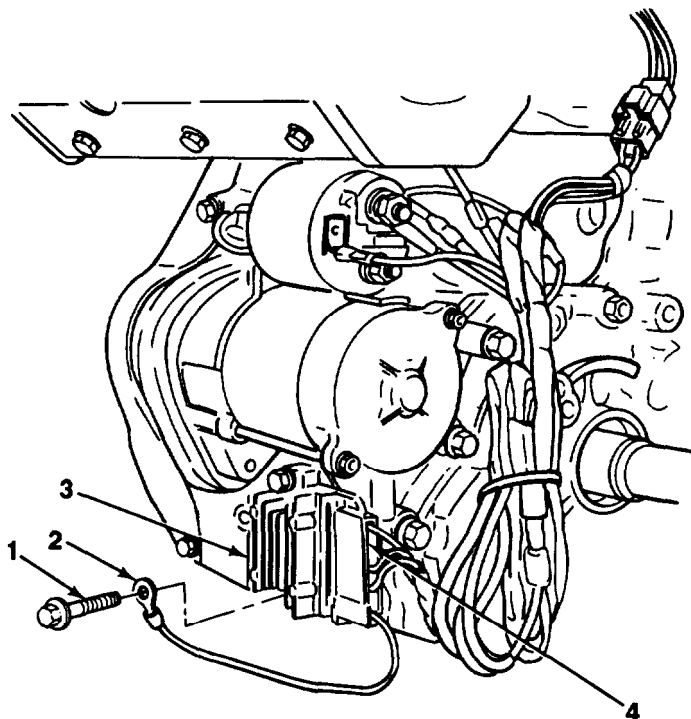


---

**4-132. ENGINE WIRING HARNESS REPLACEMENT (Con't).**

---

7. Install wiring harness ground wire (2) to regulator (3) with flange bolt (1).
8. Connect wiring harness connector (4) to regulator (3).

**Follow-on Tasks:**

- Connect negative (-) ground cable to battery (see paragraph 4-45).
- Start engine (see paragraph 2-20).

---

## 4-133. GLOW PLUG REPLACEMENT.

---

*This Task Covers:*

- a. Removal b. Installation
- 

*Initial Setup:*

**Equipment Conditions:**

- <sup>1</sup> Negative (-) ground cable disconnected from battery (see paragraph 4-45).
- <sup>1</sup> Oil cooler cover removed (see paragraph 4-117).

**Tools/Test Equipment:**

- General mechanic's tool kit (Item 30, Appendix G)
  - Torque wrench, 0-175 lb.-ft. (Item 42, Appendix G)
- 

**a. REMOVAL**

1. Lift off boot (2).
2. Remove nut (3), cord (1), and washer (4) from glow plug (5).
3. Remove nut (6) from nozzle holder (12). Slide back nut on injection pipe (7).
4. Remove glow plug (5) from cylinder head (8).

**NOTE**

**Perform steps 5 and 6 only if cord is damaged.**

5. Disconnect cord connector (11) from engine wiring harness connector (10).
6. Remove flange bolt (13), clamp (9), and cord (1) from cylinder head (8).

**b. INSTALLATION**

**NOTE**

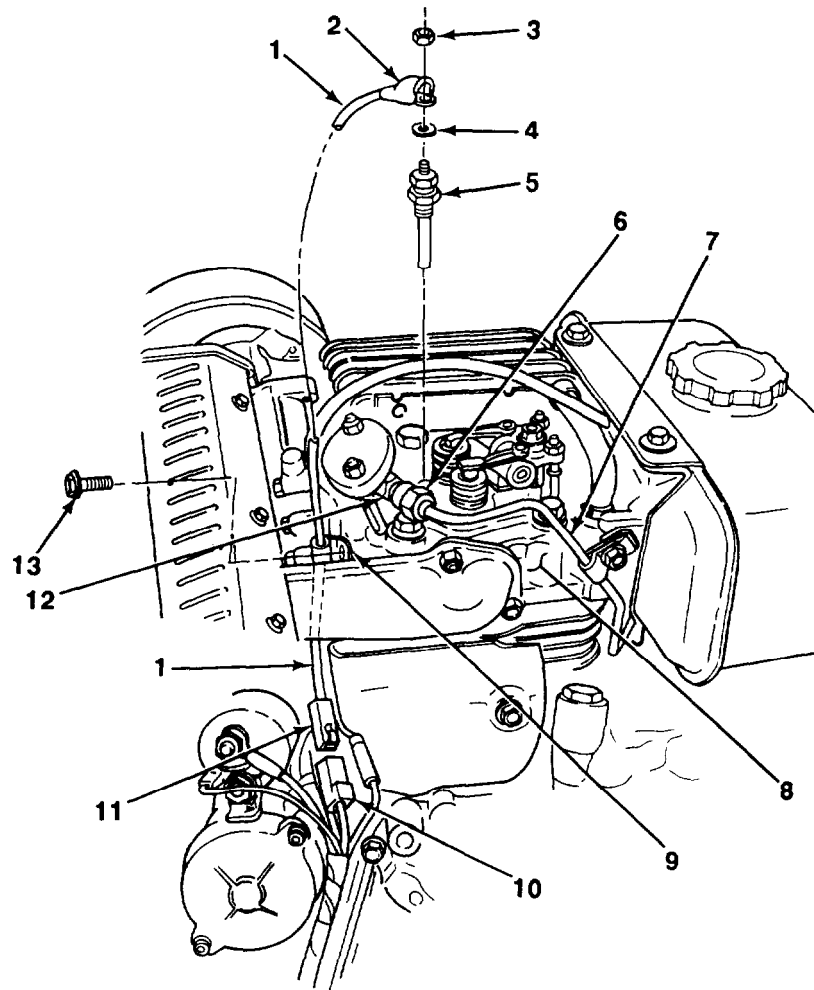
**Perform steps 1 and 2 only if cord was removed.**

1. Install cord (1) on cylinder head (8) with clamp (9) and flange bolt (13).
2. Connect cord connector (11) to engine wiring harness connector (10).
3. Install glow plug (5) on cylinder head (8). Torque glow plug to 15-18 lb.-ft. (20-24 N·m).
4. Install nut (6) on nozzle holder (12).
5. Install washer (4) and cord (1) on glow plug (5) with nut (3).
6. Position boot (2) over nut (3).

---

**4-133. GLOW PLUG REPLACEMENT (Con't).**

---

**Follow-on Tasks:**

- Install oil cooler cover (see paragraph 4-117).
- Connect negative (-) ground cable to battery (see paragraph 4-45).
- Start engine (see paragraph 2-20) and check operation of engine.

---

## 4-134. WINTERIZING ENGINE [BELOW 0°F (-18°C)].

---

*This Task Covers: Winterizing*

---

*Initial Setup:*

**Materials/Parts:**

- Hydraulic fluid (Item 15, Appendix F)
- Diesel fuel (item 18, Appendix F)
- Lubricating oil (Item 21, Appendix F)
- Rags (Item 25, Appendix F)
- One air cleaner element
- One fuel filter

**Tools/Test Equipment:**

- General mechanic's tool kit (Item 30, Appendix G)
- 

**WINTERIZING**

1. Change crankcase oil to arctic grade according to instructions in paragraph 4-118 and the following steps:
  - (a) Operate engine for five minutes (see paragraph 2-20).
  - (b) Drain crankcase oil.
  - (c) Flush oil filter with arctic grade lubricating oil.
  - (d) Fill crankcase with arctic grade lubricating oil.

**CAUTION**

**Running engine with arctic oil for extended periods of time at room or elevated temperatures will cause premature engine wear.**

- (e) Operate engine for two minutes (see paragraph 2-20).
  - (f) Drain crankcase oil.
  - (g) Fill crankcase with arctic grade lubricating oil.
2. Change diesel fuel to arctic grade according to Instructions in paragraph 4-125 and the following steps:
  - (a) Drain fuel from fuel tank.
  - (b) Operate engine until all remaining fuel is used (see paragraph 2-20).
  - (c) Install new fuel filter.

**NOTE**

**Moisture in air of fuel tank can condense and then freeze in fuel system, preventing engine from starting. To minimize this problem, ensure fuel tank is filled to capacity. A fresh or unopened container of DF-A should be used to increase fuel combustibility.**

- (d) Fill fuel tank with arctic grade fuel.

---

**4-134. WINTERIZING ENGINE [BELOW 0° F (-18° C)] (Con't).**

---

3. Operate engine for two minutes to fully circulate lubricating oil and fuel (see paragraph 2-20).
4. Fill fuel tank to capacity with arctic grade fuel.
5. Check glow plug for proper operation by confirming correct voltage and resistance (see Unit Troubleshooting, Table 4-2, Malfunction 22).
6. Install new air cleaner element (see paragraph 4-123).
7. Verify that battery is fully charged and battery cables are in good condition and properly connected (see paragraphs 4-43 and 4-45).
8. Fill hydraulic reservoir as required to capacity as indicated on dipstick (see paragraph 3-7).

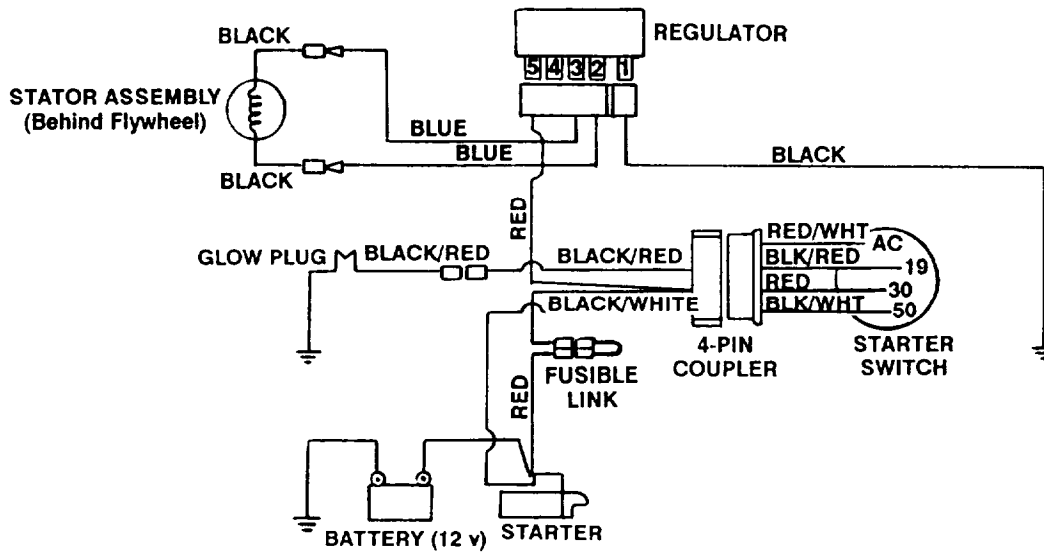
---

**4-135. ENGINE WIRING DIAGRAM.**

---

**NOTE**

**Refer to this wiring diagram when performing electrical troubleshooting or maintenance.**



## Section XVII. SPECIAL PURPOSE KITS MAINTENANCE

Paragraph Number	Paragraph Title	Page Number
4-136.	Redundant Power Kit Hose Assemblies Repair .....	4-395
4-137.	Storage Box Mounting Brackets Replacement (Side Lift Kit) .....	4-398
4-138.	Storage Box Replacement (Side Lift Kit) .....	4-399
4-138.1.	Cold Start Kit Installation .....	4-400
4-138.2.	Enclosure Assembly Repair (Cold Start Kit) .....	4-400.3

---

### 4-136. REDUNDANT POWER KIT HOSE ASSEMBLIES REPAIR.

---

*This Task Covers:*

- |                |             |
|----------------|-------------|
| a. Disassembly | b. Assembly |
|----------------|-------------|
- 

*Initial Setup:*

**Materials/Parts:**

- Rags (Item 25, Appendix F)
- Four preformed packings

**Tools/Test Equipment:**

- General mechanic's tool kit (Item 30, Appendix G)
  - Machinist's vise (Item 36, Appendix G)
- 

**NOTE**

A suitable container should be used to catch any draining hydraulic fluid. Ensure that spills are properly cleaned.

**a. DISASSEMBLY**

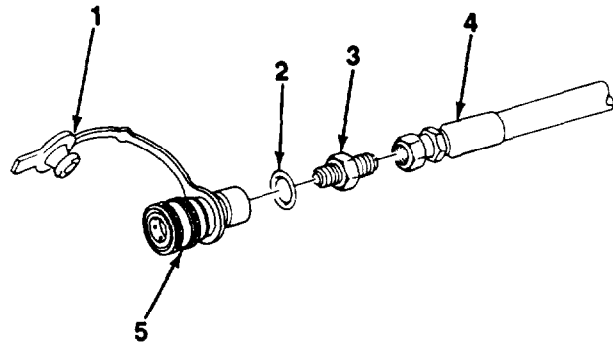
**NOTE**

- Perform steps 1 through 5 to disassemble hose assembly with quick disconnect couplers on both ends.
- Perform steps 1 and 6 through 9 to disassemble hose assembly with quick disconnect nipples on both ends.

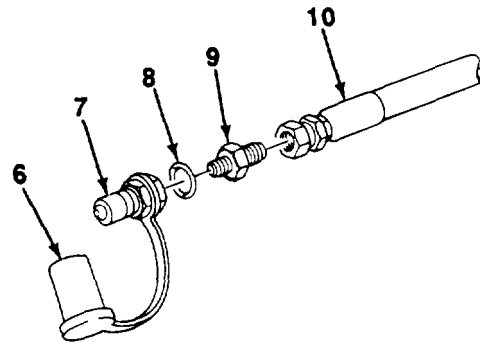
1. Secure hose assembly in a vise.

**4-136. REDUNDANT POWER KIT HOSE ASSEMBLIES REPAIR (Con't).**

2. Remove quick disconnect coupler (5) and preformed packing (2) from straight connector (3). Discard preformed packing.
3. Remove dust cap (1) from quick disconnect coupler (5).
4. Remove straight connector (3) from hose (4).
5. Repeat steps 1 through 4 for other end of hose (4).



6. Remove quick disconnect nipple (7) and preformed packing (6) from straight connector (9). Discard preformed packing.
7. Remove dust plug (6) from quick disconnect nipple (7).
8. Remove straight connector (9) from hose (10).
9. Repeat steps 1 and 6 through 8 for other end of hose (10).



**b. ASSEMBLY**

**NOTE**

- Perform steps 1 through 5 to assemble hose assembly with quick disconnect nipples on both ends.
- Perform steps 1 and 6 through 9 to assemble hose assembly with quick disconnect couplers on both ends.

1. Secure hose (4 or 10) in a vise.
2. install straight connector (9) on hose (10).



---

**4-136. REDUNDANT POWER KIT HOSE ASSEMBLIES REPAIR (Con't).**

---

3. Install dust plug (6) on quick disconnect nipple (7).
4. Install new preformed packing (8) and quick disconnect nipple (7) on straight connector (9).
5. Repeat steps 1 through 4 for other end of hose (10).
6. Install straight connector (3) on hose (4).
7. Install dust cap (1) on quick disconnect coupler (5).
8. Install new preformed packing (2) and quick disconnect coupler (5) on straight connector (3).
9. Repeat steps 1 and 6 through 8 for other end of hose (4).

---

## 4-137. STORAGE BOX MOUNTING BRACKETS REPLACEMENT (SIDE LIFT KIT).

---

*This Task Covers:*

- a. Removal b. Installation
- 

*Initial Setup:*

**Equipment Conditions:**

- Storage box removed (see paragraph 4-138).

**Materials/Parts:**

- Eight locknuts

**Tools/Test Equipment:**

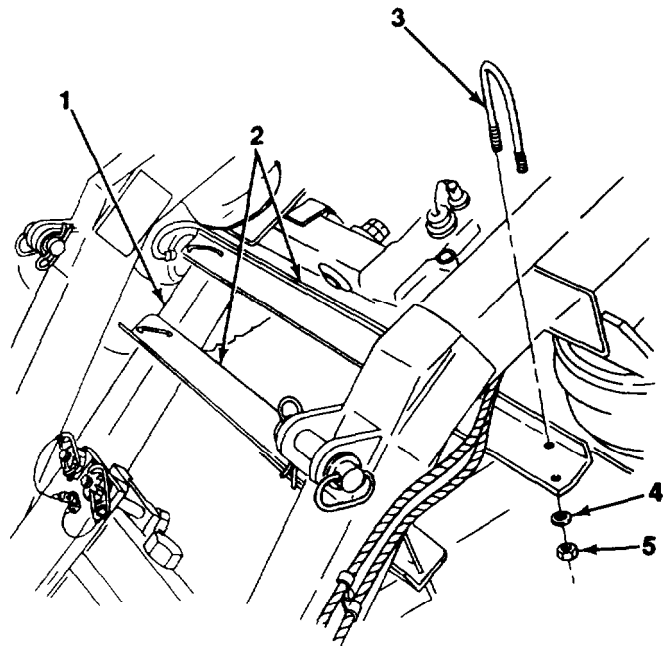
- General mechanic's tool kit (item 30, Appendix G)
- 

### **a. REMOVAL**

Remove eight locknuts (5), flatwashers (4) four U-bolts (3) and two mounting brackets (2) from axle assembly (1) on front doily. Discard locknuts.

### **b. INSTALLATION**

1. Position two mounting brackets (2) on axle assembly (1) of front doily. To ensure correct positioning of mounting brackets, place storage box on mounting brackets with hinged side of storage box facing pivoting tray. Adjust positioning as required. Remove storage box.
2. Install four U-bolts (3) eight flatwashers (4) and new locknuts (5) on axle assembly (1).



**Follow-on Tasks:**

- Install storage box (see paragraph 4-138).

---

## 4-138. STORAGE BOX REPLACEMENT.

---

*This Task Covers:*

- a. Removal b. installation
- 

*initial Setup:*

**Materials/Parts:**

- Adhesive (item 1, Appendix F)
- Four locknuts

**Tools/Test Equipment:**

- General mechanic's tool kit (item 30, Appendix G)
- 

### a. REMOVAL

1. Open storage box (2) and remove contents.
2. Remove four locknuts (6), flatwashers (7), cap-screws (4), flatwashers (3) and storage box (2) from two mounting brackets (1). Discard locknuts.
3. If seal (5) is damaged, remove.

### b. INSTALLATION

**NOTE**

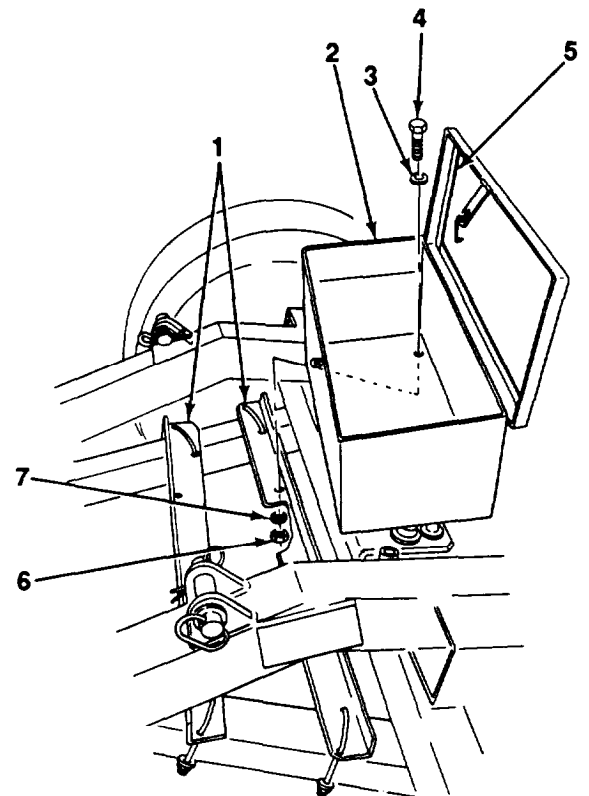
Ensure that seal mounting surface on cover is clean and dry.

1. If removed, install seal (5) with adhesive.

**NOTE**

Hinged side of storage box should be installed facing pivoting tray.

2. Install storage box (2) on two mounting brackets (1) with four flatwashers (3), capscrews (4), flatwashers (7), and new locknuts (6).
3. Place contents in storage box (2) and close.



---

## 4-138.1. COLD START KIT INSTALLATION.

---

*This Task Covers:*

installation

---

*Initial Setup:*

**Equipment Conditions:**

- Engine starter switch set to OFF position (see paragraph 2-20).

**Tools/Test Equipment:**

- General mechanic's tool kit (Item 30, Appendix G)

**Materials/Parts:**

- Two locknuts
- Two springwashers

**Personnel Required:** Two

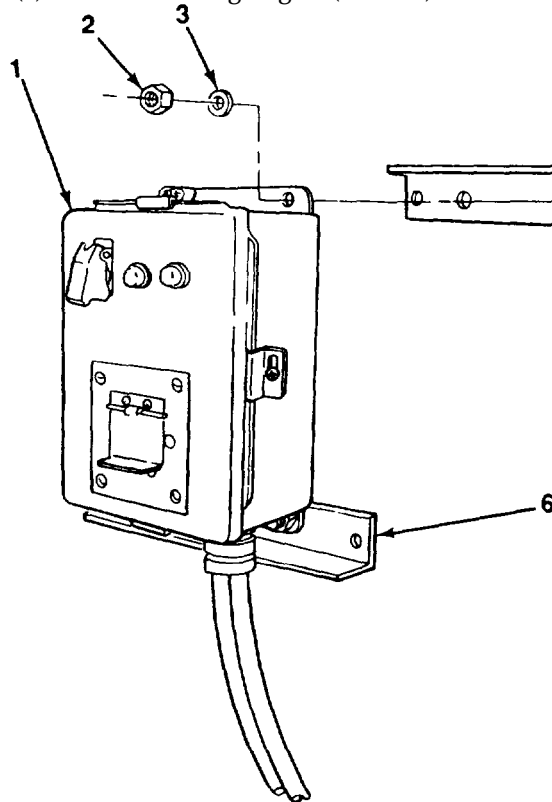
---

### INSTALLATION

#### NOTE

Installation of cold start kit to front and rear dollies is similar. Differences will be pointed out as they occur. Front doily installation is shown.

1. Install enclosure assembly (1) to two mounting angles (4 and 6) with four capscrews (5), flatwashers (3), and locknuts (2).



---

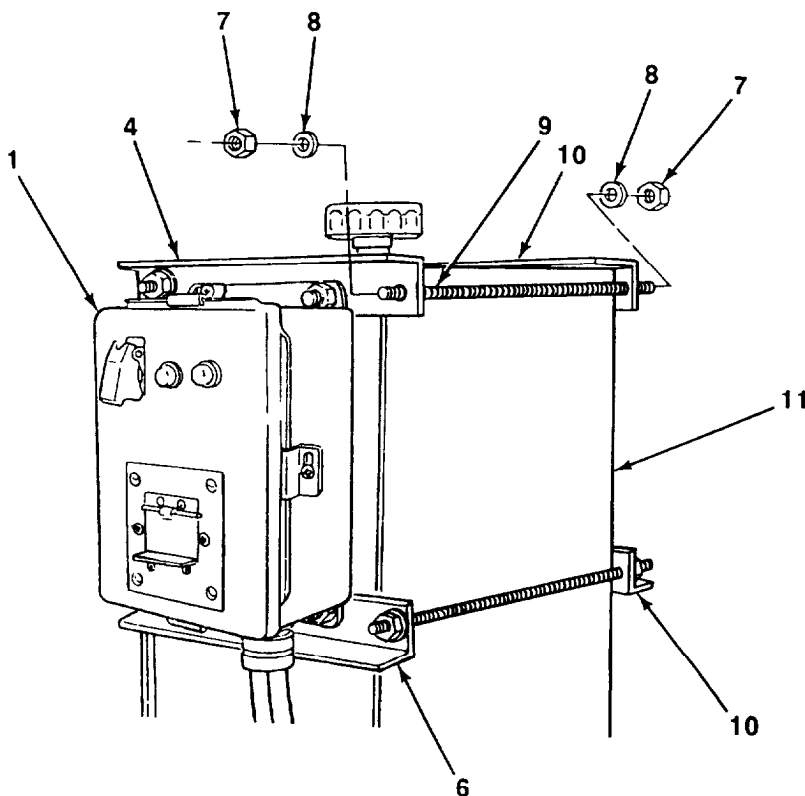
**4-138.1. COLD START KIT INSTALLATION (Con't).**

---

**CAUTION**

If enclosure assembly is not installed in proper location at hydraulic reservoir, interference with telescopic brace will occur during operation, causing damage to enclosure assembly.

2. Position enclosure assembly (1) with mounting angles (4 and 6) against hydraulic reservoir (11). On front dolly, top mounting angle (4) should be at top of reservoir. On rear dolly, top mounting angle should be 6 in. (15 cm) down from top of reservoir.
3. Secure enclosure assembly (1) to hydraulic reservoir (11) with four mounting angles (4, 6, and 10), four threaded rods (9), eight flatwashers (8), and locknuts (7).

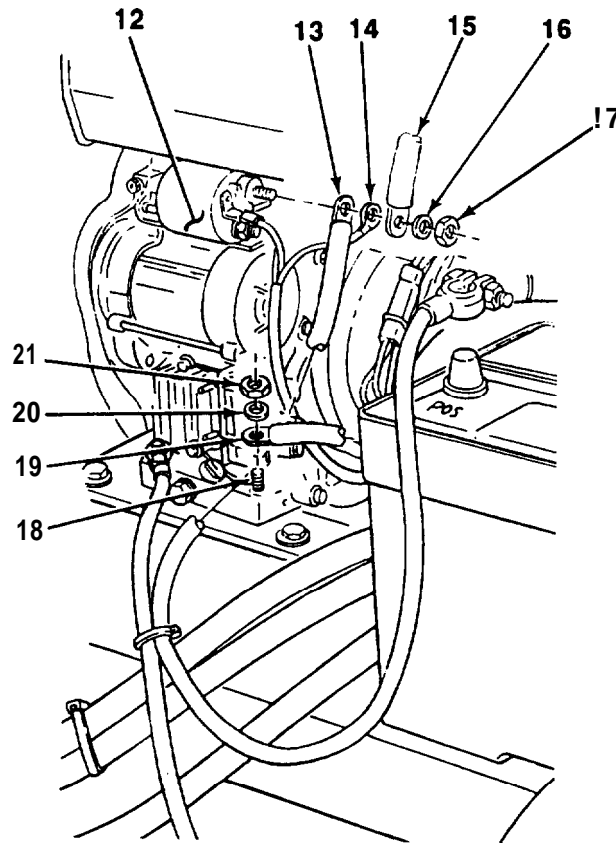


---

#### 4-138.1. COLD START KIT INSTALLATION (Con't).

---

4. Remove nut (17) and springwasher (16) from starter (12). Discard springwasher.
5. Connect positive (+) red cable (15) to starter (12), without disconnecting positive (+) battery cable (13) and wiring harness red wire (14). Install new springwasher (16) and nut (17).
6. Remove locknut (21) and flatwasher (20) from engine mounting capscrew (18) that is NOT used to secure negative (-) battery cable. Discard locknut.
7. Connect negative (-) black cable (19) to engine mounting capscrew (18) with flatwasher (20) and new locknut (21).



---

**4-138.2. ENCLOSURE ASSEMBLY REPAIR (COLD START KIT).**


---

*This Task Covers:*

- |                       |                     |
|-----------------------|---------------------|
| a. Switch Replacement | b. Lamp Replacement |
|-----------------------|---------------------|
- 

*Initial Setup:*

**Equipment Conditions:**

- Engine starter switch set to OFF position (see paragraph 2-20).
- Enclosure assembly switch set to OFF position.

**Tools/Test Equipment:**

- General mechanic's tool kit (Item 30, Appendix G)

**Materials/Parts:**

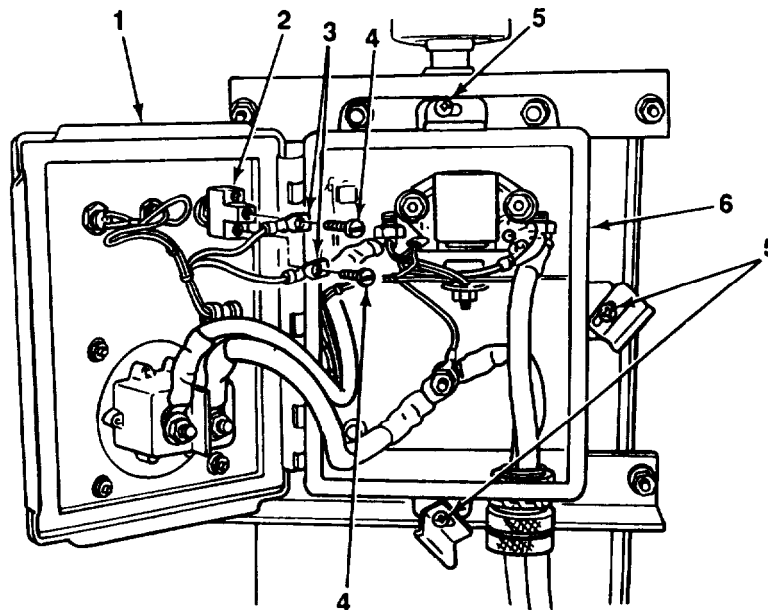
- Marker tags (Item 28, Appendix F)
- 

**a. SWITCH REPLACEMENT**

**NOTE**

**All wires should be tagged before removal. Refer to paragraph 4-18 for tagging instructions.**

1. Loosen three screws (5) and open cover (1) of enclosure assembly (6).
2. Remove two terminal screws (4) and disconnect two wires (3) from switch (2).



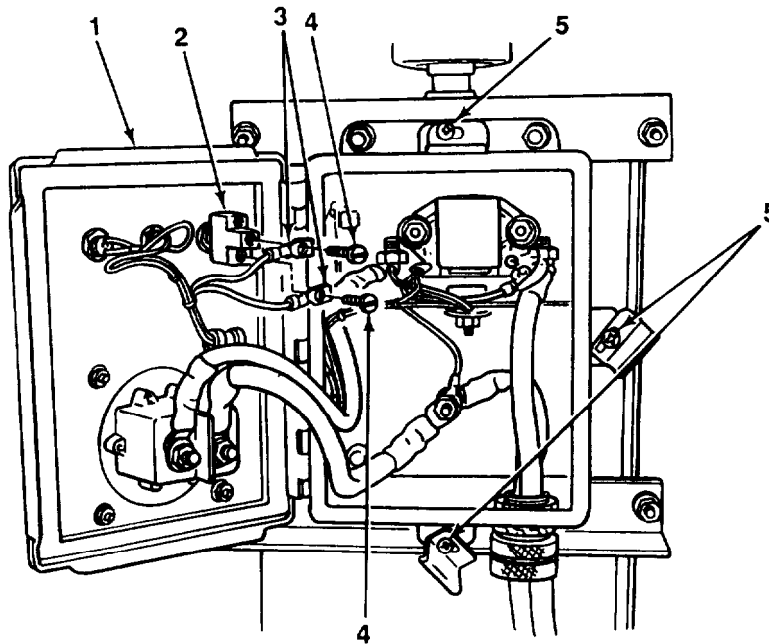
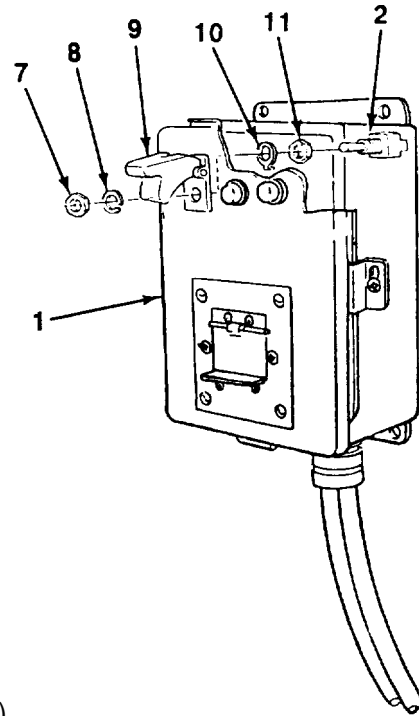
4-138.2. ENCLOSURE ASSEMBLY REPAIR (COLD START KIT) (Con't).

NOTE

- Switch mounting hardware may be reused, if not damaged.

- Note position of inner nut on switch to ensure proper installation.

3. On outside of cover (1), raise guard (9) out of way of switch (2). Remove nut (7) and lockwasher (8) from shaft of switch and remove switch. Remove locking ring (10) and nut (11).
4. Install nut (11) and locking ring (10) on shaft of switch (2).
5. Position switch (2) through cover (1) with tang of locking ring (10) indexed with keyway in cover.
6. On outside of cover (1), install lockwasher (8) and nut (7) on shaft of switch (2).
7. Connect two wires (3) to switch (2) with two terminal screws (4).
8. Close cover (1) and tighten three screws (5).





---

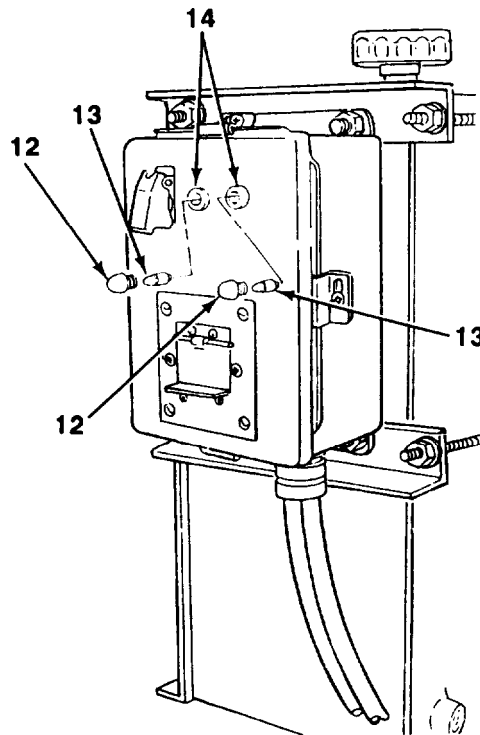
**4-138.2. ENCLOSURE ASSEMBLY REPAIR (COLD START KIT) (Con't).**

---

**b. LAMP REPLACEMENT****NOTE**

**Green and red lamps are replaced the same way.**

1. Turn lens (12) counterclockwise and remove from socket (14).
2. Remove lamp (13) from lens (12).
3. Install lamp (13) in lens (12).
4. Turn lens (12) clockwise to install in socket (14).





## Section XVIII. PREPARATION FOR STORAGE OR SHIPMENT

Paragraph Number	Paragraph Title	Page Number
4-139.	General . . . . .	4-401
4-140.	Definition of Administrative Storage . . . . .	4-401
4-141.	Preparation of Equipment for Administrative Storage . . . . .	4-401
4-142.	Care of Equipment in Administrative Storage . . . . .	4-403
4-143.	Procedures for Common Components and Miscellaneous Items . . . . .	4-404
4-144.	Removal of Equipment From Administrative Storage . . . . .	4-404
4-145.	Preparation of Equipment for Shipment . . . . .	4-405
4-146.	Aircraft Loading . . . . .	4-405
Table 4-3.	Exercise Schedule . . . . .	4-404

---

### 4-139. GENERAL.

- a. This chapter contains requirements and procedures for administrative storage of equipment that is issued to and in use by Army activities worldwide.
- b. The requirements specified herein are necessary to maintain equipment in administrative storage in such a way as to achieve the maximum readiness condition.
- c. Equipment that is placed in administrative storage should be capable of being readied to perform its mission within a 24-hour period, or as otherwise may be prescribed by the approving authority. Before equipment is placed in administrative storage, a current Preventive Maintenance Checks and Services (PMCS) should be completed and deficiencies corrected.
  - d. Report equipment in administrative storage as prescribed for all reportable equipment.
  - e. Perform inspections, maintenance services, and lubrication as specified herein.
- f. Records and reports to be maintained for equipment in administrative storage are those prescribed by DA Pam 738-750 for equipment in use.
- g. A 10% variance is acceptable on time, running hours, or mileage used to determine the required maintenance actions.
- h. Accomplishment of applicable PMCS, as mentioned throughout this chapter, will be on a semiannual basis.

---

### 4-140. DEFINITION OF ADMINISTRATIVE STORAGE.

The placement of equipment in administrative storage can be for short periods of time when a shortage of maintenance effort exists. Items should be ready for use within the time factors as determined by the directing authority. During the storage period, appropriate maintenance records will be kept.

---

### 4-141. PREPARATION OF EQUIPMENT FOR ADMINISTRATIVE STORAGE.

a. **Storage Site**

- (1) Select the best available site for administrative storage. Separate stored equipment from equipment in use. Conspicuously mark the area "Administrative Storage".

---

#### 4-141. PREPARATION OF EQUIPMENT FOR ADMINISTRATIVE STORAGE (Con't).

---

(2) Covered space is preferred.

(3) Open sites should be improved hardstand, if available. Unimproved sites should be firm, well-drained, and free of excessive vegetation.

b. **Storage Plan.**

(1) Store dolly set with lift cylinders fully retracted and bottom beams resting on dunnage such as wood, rather than directly on the ground.

(1.1) On dolly sets with standard lift cylinders, pack recess between lift cylinder head inside diameter (wiper lip clearance bore) and wiper lip with grease (Item 19, Appendix F).

(1.2) If dolly set is going to sit unused for more than a month, coat rods with GAA grease (Item 35, Appendix F), then wrap rods with waterproof barrier material (Item 2, Appendix F). Use moisture-resistant tape (Item 36, Appendix F) to hold barrier material in place. Remove tape, barrier material, and grease from rods when returning dolly set to service.

(2) Store equipment so as to provide maximum protection from the elements and to provide access for inspection, maintenance, and exercising. Anticipate removal or deployment problems and take suitable precautions.

(3) Take into consideration environmental conditions, such as extreme heat or cold; high humidity; blowing sand, dust, or loose debris; soft ground; mud; heavy snows; or any combination thereof, and take adequate precautions.

(4) Establish a fire plan and provide for adequate fire fighting equipment and personnel.

c. **Maintenance Services and Inspections.**

(1) **Maintenance Services.** Prior to storage, perform the next scheduled Unit PMCS, disconnect battery cables (see paragraph 4-45), and drain fuel from fuel tank (see paragraph 4-125).

(2) **Inspection.** Inspect and approve the equipment prior to storage. Do not place nonmission-capable equipment in storage.

d. **Auxiliary Equipment and Basic Issue Items.**

(1) Process auxiliary and basic issue items simultaneously with the major item to which they are assigned.

(2) If possible, store auxiliary and basic issue items with the major item.

(3) If stored apart from the major item, mark auxiliary and basic issue items with marker tags (Item 28, Appendix F) indicating the major item, its registration or serial number and location, and store in protective type closures. In addition, place a tag or list indicating the location of the removed items in a conspicuous place on the major item.

e. **Correction of Shortcomings and Deficiencies.** Correct all shortcomings and deficiencies prior to storage, or obtain a deferment from the approving authority.

f. **Lubrication.** Lubricate equipment in accordance with instructions in Chapter 3, Section I.

g. **General Cleaning, Painting, and Preservation.**

**CAUTION**

**DO NOT direct water or steam, under pressure, against unsealed electrical systems or any exterior opening. Failure to follow this caution may result in damage to equipment.**

(1) **Cleaning.** Clean the equipment of dirt, grease, and other contaminants, but do not use vapor degreasing.

(2) **Painting.** Remove rust and damaged paint by scraping, wire brushing, sanding, or buffing. Sand to a smooth finish and spot paint as necessary (see TB 43-0209).

---

#### 4-141. PREPARATION OF EQUIPMENT FOR ADMINISTRATIVE STORAGE (Con't).

---

(3) **Preservation.** After cleaning and drying, immediately coat unpainted metal surfaces with oil or grease, as appropriate (see Chapter 3, Section I).

#### NOTE

- **Place a piece of barrier material (Item 2, Appendix C) between desiccant bags and metal surfaces.**
- **Air circulation under draped covers reduces deterioration from moisture or heat.**

(4) **Weatherproofing.** Sunlight, heat, moisture (humidity), and dirt tend to accelerate deterioration. Install all covers (including vehicle protective closures) authorized for the equipment. Close and secure all openings except those required for venting and draining. Seal openings to prevent the entry of rain, snow, or dust. Insert desiccant when complete seal is required. Place equipment, and provide blocking or framing, to allow for ventilation and water drainage. Support cover away from item surfaces which may rust, rot, or mildew.

---

#### 4-142. CARE OF EQUIPMENT IN ADMINISTRATIVE STORAGE.

---

a. **Maintenance Services.** After equipment has been placed in administrative storage, inspect, service, and exercise as specified herein.

b. **Inspection.** Inspection will usually be visual and must consist of at least a walkaround examination of all equipment to detect any deficiencies. Inspect equipment in open storage weekly and equipment in covered storage monthly. Inspect all equipment immediately after any severe storm or environmental change. The following are examples of things to look for during a visual inspection:

- (1) Low or flat tires.
- (2) Condition of preservatives, seals, and wraps.
- (3) Corrosion or other deterioration.
- (4) Missing or damaged parts.
- (5) Water in compartments.
- (6) Any other readily recognizable shortcomings or deficiencies.

c. **Repair During Administrative Storage.** Keep equipment in an optimum state of readiness. Accomplish the required services and repairs as quickly as possible. Whenever possible, perform all maintenance on-site.

d. **Exercising.** Exercise equipment in accordance with Table 4-3, Exercise Schedule, and the following instructions.

(1) **Vehicle Major Exercise.** Depreserve equipment by removing only that material restricting exercise. If dolly set was stored with lift cylinder extended, before operation extend cylinders an additional 2-3 in. (5-8 cm) (DO NOT retract), then wipe rods clean with a clean rag (Item 25, Appendix F) soaked in lubricating oil (Item 23, Appendix F). Close all drains, remove blocks, and perform all *Before* operational checks. Couple dolly set to towing vehicle and drive for at least 25 mi (40 km). Make several right and left 90° turns. Make several hard braking stops without skidding. While exercising, and when it is safe and convenient, operate all other functional components and perform all *During* and *After* operational checks.

---

#### 4-142. CARE OF EQUIPMENT IN ADMINISTRATIVE STORAGE (Con't).

---

(2) **Scheduled Services.** Scheduled services will include inspection per subparagraph b and will be conducted in accordance with Table 4-3. Lubricate in accordance with instructions in Chapter 3, Section I.

(3) **Corrective Action.** Immediately take action to correct shortcomings and deficiencies noted. Record inspection and exercise results on DA Form 2404. Record and report all maintenance actions on DA Form 2407. After exercising, restore the preservation to the original condition. Replenish lubricants used during exercising and note the amount on DA Form 2408.

**Table 4-3. Exercise Schedule.**

Weeks	2	4	6	8	10	12	14	16	18	20	22	24
PMCS												X
Scheduled Services		X		X		X		X		X		
Major Exercise												X

e. **Rotation.** Rotate items in accordance with any rotational plan that will keep the equipment in an operational condition and reduce the maintenance effort.

---

#### 4-143. PROCEDURES FOR COMMON COMPONENTS AND MISCELLANEOUS ITEMS.

---

a. **Tires.** Visually inspect tires during each walkaround inspection. This inspection includes checking tires with a tire gage. Inflate, repair, or replace as necessary those found to be low, damaged, or excessively worn. Mark inflated and repaired tires with a crayon for checking at the next inspection.

b. **Airbrake System Valves.** Drain condensation from valves by opening draincocks or removing drain plugs. Place tags on valves as a reminder to replace drain plugs and close draincocks when equipment is put into service.

c. **Seals.** Seals may develop leaks during storage or shortly thereafter. If leaking persists, refer to the applicable maintenance section in this manual for corrective maintenance procedures.

---

#### 4-144. REMOVAL OF EQUIPMENT FROM ADMINISTRATIVE STORAGE.

---

a. **Activation.**

(1) Restore the equipment to normal operating condition in accordance with the instructions contained in Chapter 4, Section II.

(2) If dolly set was stored with lift cylinders extended, before operation extend cylinders an additional 2-3 in. (5-8 cm) (DO NOT retract), then wipe rods clean with a clean rag (Item 25, Appendix F) soaked in lubricating oil (Item 23, Appendix F).

b. **Servicing.** Resume the maintenance service schedule in effect at the commencement of storage or service the equipment before the scheduled dates in order to produce a staggered maintenance workload.

---

**4-145. PREPARATION OF EQUIPMENT FOR SHIPMENT.**

---

a. Dolly sets are shipped coupled in transport (raised) position; lift cylinder rods are extended. Apply a light coat of lubricating oil (Item 23, Appendix F) to rods with a clean rag (Item 25, Appendix F). On dolly sets with standard lift cylinders, pack recess between lift cylinder head inside diameter (wiper lip clearance bore) and wiper lip with grease (Item 19, Appendix F). After shipment and before operation, remove oil coating and grease with a clean dry rag.

b. Refer to FM 55-21, TM 55-601, and TM 743-200-1 for additional instructions on processing, storage, and shipment of materiel.

c. Dolly sets that have been removed from storage for shipment do not have to be reprocessed if they will reach their destination within the administrative storage period. Reprocess only if inspection reveals any corrosion or if anticipated in-transit weather conditions make it necessary.

d. When a dolly set is received and has already been processed for domestic shipment, as indicated on DD Form 1397, the dolly set does not have to be reprocessed for storage unless corrosion and deterioration are found during the inspection upon receipt. List on SF Form 364 all discrepancies found because of poor preservation, packaging, packing, marking, handling, loading, storage, or excessive preservation. Repairs that cannot be handled by the receiving unit must have tags attached listing needed repairs. A report of these conditions will be submitted by the unit commander for action by an ordnance maintenance unit.

---

**4-146. AIRCRAFT LOADING.**

---

a. Dolly set, attached to a fully loaded 8 x 8 x 20 ISO container, can be loaded onto a C-130 or C-141 aircraft using only itself and aircraft winch.

b. Pull dolly set backward into aircraft using aircraft winch attached to rear dolly pintle assembly.

c. During loading, adjust lift cylinders as required to ensure that shelter does not exceed height requirements or contact aircraft's ramp crest.

d. Once inside aircraft, lower shelter to floor and secure in tie-down position per data plate instructions (see paragraph 1-12).





**CHAPTER 5  
DIRECT SUPPORT AND GENERAL SUPPORT MAINTENANCE**

**Section I. FRONT AND REAR AXLE ASSEMBLIES MAINTENANCE**

Paragraph Number	Paragraph Title	Page Number
5-1.	Front or Rear Axle Assembly Replacement .....	5-1
5-2.	Front Drawbar Bushings Replacement.....	5-4

**5-1. FRONT OR REAR AXLE ASSEMBLY REPLACEMENT.**

*This Task Covers:*

- |            |                 |
|------------|-----------------|
| a. Removal | b. Installation |
|------------|-----------------|

*Initial Setup:*

**Equipment Conditions:**

- Dolly set lowered, front and rear dollies detached (see paragraph 2-8).
- Air lines disconnected from airbrake chambers (see paragraph 4-72 or 4-73).
- Brakes caged (rear axle assembly) (see paragraph 4-56).

**Materials/Parts:**

- Grease (Item 19, Appendix F)
- **Tools/Test Equipment:**
  - General mechanic's tool kit (item 30, Appendix G)
  - Hydraulic jack, 10 ton (Item 16, Appendix G)
  - Adjustable wrench (Item 37, Appendix G)

**Personnel Required:** Three



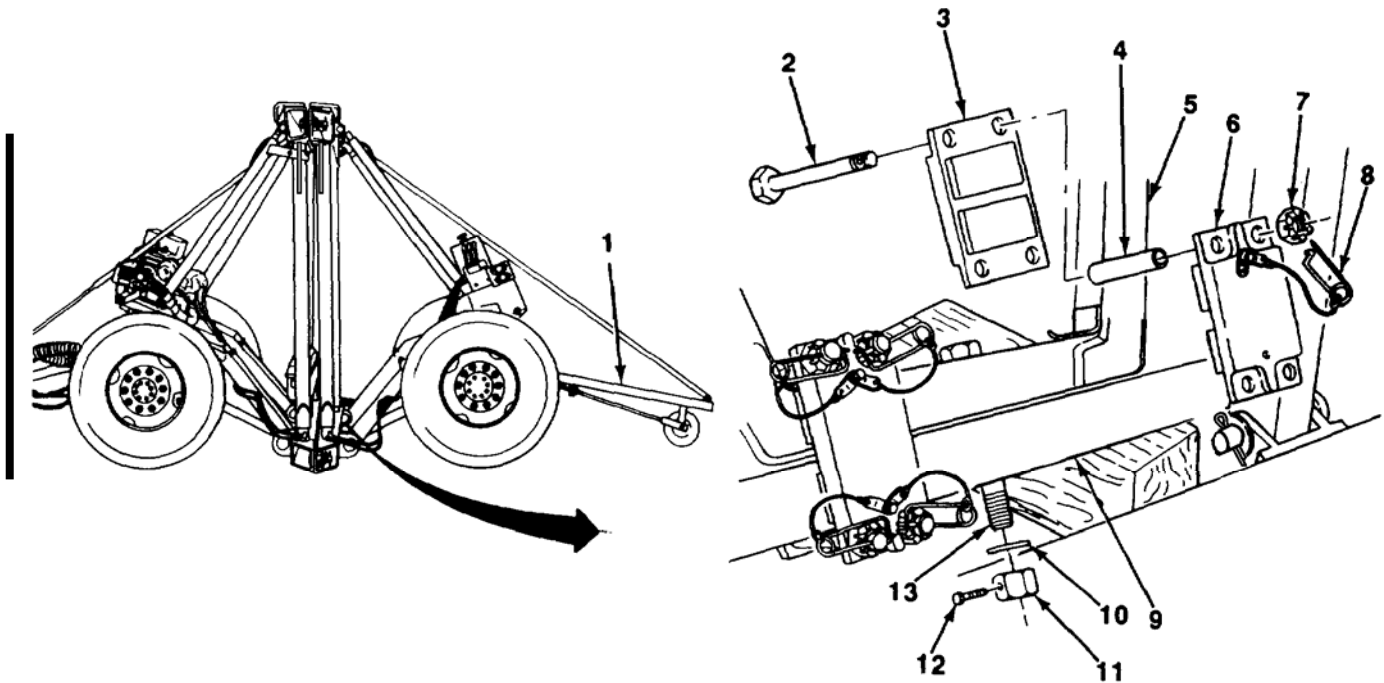
**Use extreme caution when handling heavy parts. Lifting device is required when parts weigh over 50 lb (23 kg) for a single person lift, over 100 lb (45 kg) for a two person lift, and over 150 lb (68 kg) for a three or more person lift. Keep clear of heavy parts supported only by lifting device. Failure to follow this warning may cause serious injury or death to personnel.**

**a. REMOVAL**

1. Remove telescopic brace (see paragraph 4-86).
2. Remove air bags (see paragraph 4-101).

**5-1. FRONT OR REAR AXLE ASSEMBLY REPLACEMENT (Cont).**

3. Place a wooden block under midpoint of axle assembly (5) at attachment point to pivot axle bracket (9).
4. Remove four safety pins (8) nuts (7) bolts (2) bottom lockout bracket (3) four sleeves (4) and top lockout bracket (8) from each end of axle assembly (5) and pivot axle bracket (9).
5. Remove setscrew (12) nut (11), washer (10), and pivot bolt (13) from axle assembly (5) and pivot axle bracket (9)



DS1022-168

6. Pull on drawbar (1) to separate axle assembly (5) from pivot axle bracket (9).
7. Continue to pull on drawbar (1) to remove axle assembly (5). Support axle assembly on wooden block.
8. Remove safety chains (front axle assembly) (see paragraph 4-51).
9. Remove drawbar (1) (see paragraph 4-53 or 4-88).
10. Remove pintle assembly (rear axle assembly) (see paragraph 490).

**b. INSTALLATION**

1. Install pintle assembly (rear axle assembly) (see paragraph 4-90).
2. Install drawbar (1) (see paragraph 4-53 or 4-88).
3. Install safety chains (front axle assembly) (see paragraph 4-51).
4. Use drawbar (1) to guide axle assembly (5), supported on a wooden block, into position on pivot axle bracket (9).

---

**5-1. FRONT OR REAR AXLE ASSEMBLY REPLACEMENT (Con?).**

---

5. Apply grease to mating surfaces of axle assembly (5) and pivot axle bracket (9),
6. Inspect pivot bolt (13) for damaged threads. If damaged, dress threads.
7. Install pivot bolt (13) through axle assembly (5) and pivot axle bracket (9). Provide support under midpoint of axle assembly at attachment point to pivot axle bracket with a wooden block .
8. Loosely install washer (10) and nut (11) on pivot bolt (13).
9. Tighten nut (11) with wrench to seat pivot bolt (13). Loosen nut, then handtighten. Wrench tighten nut 1 to 1 ¼ flats. Install setscrew (12) in nut.

**NOTE**

**Welded pads on axle and pivot axle bracket identify correct installation location of lockout bracket assemblies.**

10. Coat four bolts (2) with grease. Install top lockout bracket (6) four sleeves (4) bottom lockout bracket (3), four bolts, and nuts (7) on each end of axle assembly (5) and pivot axle bracket (9). Handtighten nuts, then tighten with wrench 1 ¼ to 2 flats. Install safety pins (8).
11. Install air bags (see paragraph 4-101).
12. Install telescopic brace (see paragraph 4-86).

**Follow-on Tasks:**

- Uncage brakes (rear axle assembly) (see paragraph 4-56).
- Connect air lines to airbrake chambers (see paragraph 4-72 or 4-73).

---

## 5-2. FRONT DRAWBAR BUSHINGS REPLACEMENT.

---

*This Task Covers:*

- a. Removal
- b. Cleaning
- c. installation

*Initial Setup:*

**Equipment Conditions:**

- Front drawbar removed (see paragraph 4-53).

**Materials/Parts:**

- Sealing compound (item 8, Appendix F)
- Dry cleaning solvent (Item 27, Appendix F)

**Tools/Test Equipment:**

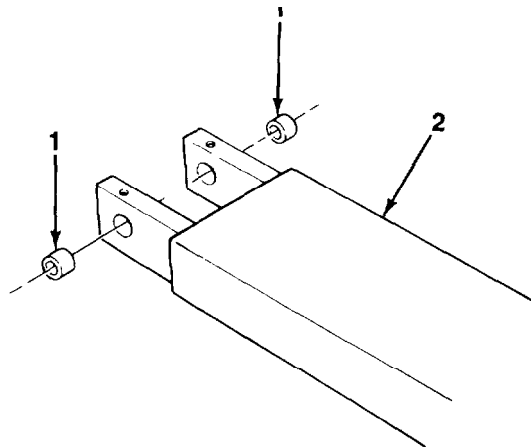
- General mechanic's tool kit (item 30, Appendix G)
- Arbor press (Item 23, Appendix G)

**General Safety Instructions:**

- Dry cleaning solvent is flammable and must not be used near an open flame. Use only in a well-ventilated area.

**a. REMOVAL**

Press out two bushings (1) from front drawbar (2).



**b. CLEANING**

**WARNING**

Dry cleaning solvent, P-D-680, is toxic and flammable. Always wear protective goggles and gloves, and use only in a well-ventilated area. Avoid contact with skin, eyes, and clothes, and DO NOT breathe vapors. DO NOT use near open flame or excessive heat. The solvent's flash point is 100°F-138°F (38°C-59°C). If you become dizzy while using cleaning solvent, immediately get fresh air and medical help. If solvent contacts eyes, immediately wash your eyes and seek medical attention.

Clean bushing bores in front drawbar to remove all traces of grease, dirt, and sealing compound.

---

5-2. FRONT DRAWBAR BUSHINGS REPLACEMENT (Con't).

---

**c. INSTALLATION**

**CAUTION**

Gap in bushings must be oriented in line with grease fittings. Improper installation of bushings will cause inadequate front drawbar lubrication and damage to bushings.

Coat bushings (1) with sealing compound and press into front drawbar (2).

Follow-on Tasks:

- Install front drawbar (see paragraph 4-53).



## Section II. BRAKEDRUM AND TIRE MAINTENANCE

Paragraph Number	Paragraph Title	Page Number
5-3	Brakedrum Repair .....	5-7
5-4	Tire Repair .....	5-8

### 5-3. BRAKEDRUM REPAIR.

*This Task Covers:*

- |               |           |
|---------------|-----------|
| a. inspection | b. Repair |
|---------------|-----------|

*Initial Setup:*

**Equipment Conditions:**

- Brakedrum removed (see paragraph 4-75).

**Tools/Test Equipment:**

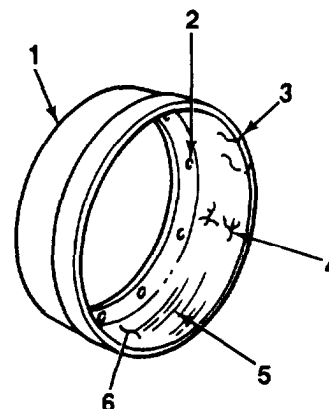
- General mechanic's tool kit (item 30, Appendix G)
- inside caliper micrometer (item 3, Appendix G)
- Brakedrum lathe (item 18, Appendix G)

**a. INSPECTION**

**WARNING**

**DO NOT** use a brakedrum that exceeds maximum wear specifications. Failure to follow this warning may result in brake failure and serious injury or death to personnel.

1. Measure inside diameter of brakedrum (1). Discard brakedrum if inside diameter exceeds 15.12 in. (38.40 cm).
2. Inspect stud holes (2) for cracks. Discard brake-drum (1) if cracks are present.
3. Inspect braking surface (6) for cracks (3) heat checking (4), and scoring (5). Reface braking surface if damaged (see subparagraph b).

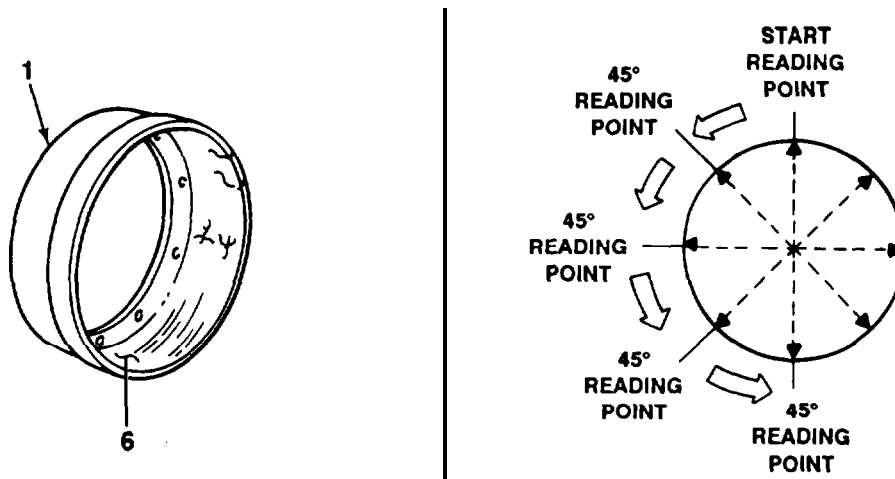


---

**5-3. BRAKEDRUM REPAIR (Con't).**

---

4. Measure braking surface (6) for out-of-round at 45° intervals. Out-of-round should not exceed 0.006 in. (0.152 mm). If runout exceeds specification, reface braking surface (see subparagraph b).



**b. REPAIR**

**WARNING**

DO NOT use a brakedrum that exceeds maximum wear specifications. Failure to follow this warning may result in brake failure and serious injury or death to personnel.

1. Reface braking surface (6) with brakedrum lathe, removing a maximum of 0.01 in. (0.25 mm) per cut.
2. Discard brakedrum (1) if inside diameter exceeds 15.12 in. (38.49 cm) after repair.

Follow-on Tasks:

- Install brakedrum (see paragraph 4-75).

---

**5-4. TIRE REPAIR.**

---

Refer to TM 9-2610-200-14 for instructions on tire repair.



**SECTION I. FRAME MAINTENANCE**

---

**5-5. SUSPENSION LINK REPLACEMENT.**

---

*This Task Covers:*

a. Removal

b. Installation

---

*Initial Setup:*

**Equipment Conditions:**

- Dolly set lowered, front and rear dollies detached (see paragraph 2-8).
- Hydraulic lift cylinder removed (see paragraph 4-110).
- Pivoting tray removed (see paragraph 4-80 or 4-81).

**Tools/Test Equipment:**

- General mechanic's tool kit (item 30, Appendix G)
- Torque wrench, 0-175 lb.-ft. (Item 42, Appendix G)
- Suitable lifting device

**Materials/Parts:**

- Sealing compound (Item 10, Appendix F)
- Grease (Item 19, Appendix F)
- Two cotter pins
- Two locknuts

**Personnel Required:** Three

---

**WARNING**

**Use extreme caution when handling heavy parts. Lifting device is required when parts weigh over 50 lb (23 kg) for a single person lift, over 100 lb (45 kg) for a two person lift, and over 150 lb (68 kg) for a three or more person lift. Keep clear of heavy parts supported only by lifting device. Failure to follow this warning may cause serious injury or death to personnel.**

---

**5-5. SUSPENSION LINK REPLACEMENT (Cont).**

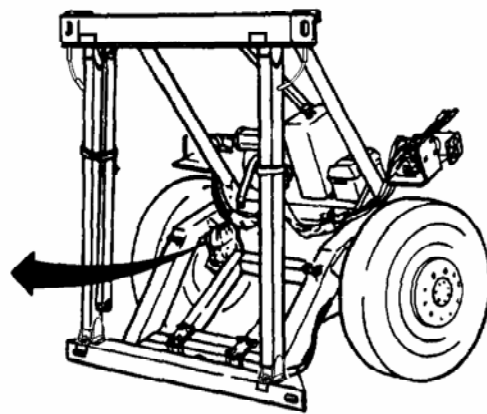
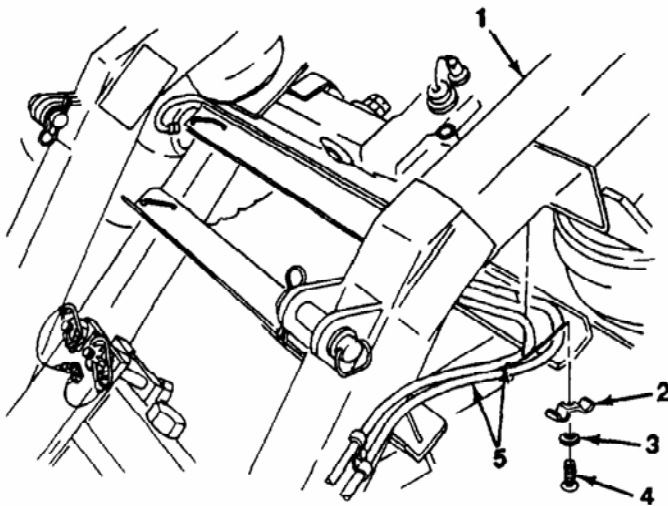
---

**a. REMOVAL**

**NOTE**

**On right side, hose assemblies are secured to both side and underside of suspension link.**

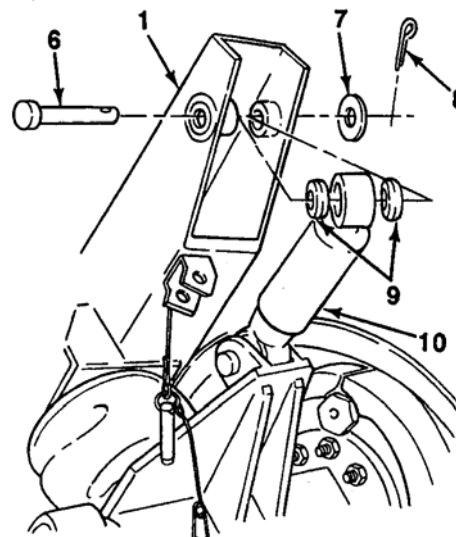
1. Remove self-tapping screw (4), flat washer (3), hose clamp (2), and two hydraulic hose assemblies (5) from side of suspension link (1).



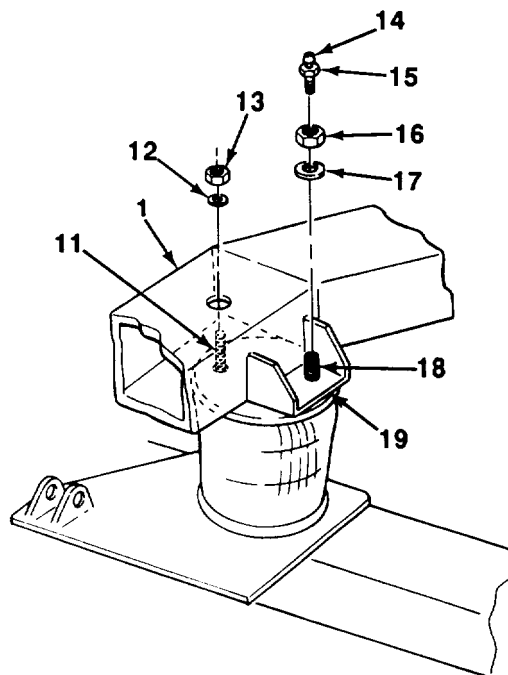
DS1022-075

## 5-5. SUSPENSION LINK REPLACEMENT (Cont).

2. Remove cotter pin (8), flatwasher (7) clevis pin (6), two bushings (9) and shock absorber (10) from suspension link (1). Discard cotter pin.
3. If removing front or rear right side suspension link, remove junction box bracket with associated components (see paragraph 4-92 or 4-95).
4. If removing front or rear left side suspension link, remove hydraulic control valve bracket with associated components (see paragraph 4-93 or 4-96).
5. If removing a front suspension link, remove brace (see paragraph 4-94).



6. Remove cap (14) and valve (15) from stud (18).
7. Remove two locknuts (13 and 16) and flatwashers (12 and 17) from studs (11 and 18) at suspension link mounting plate (19). Discard locknuts.
8. Support suspension link (1) with a suitable lifting device.

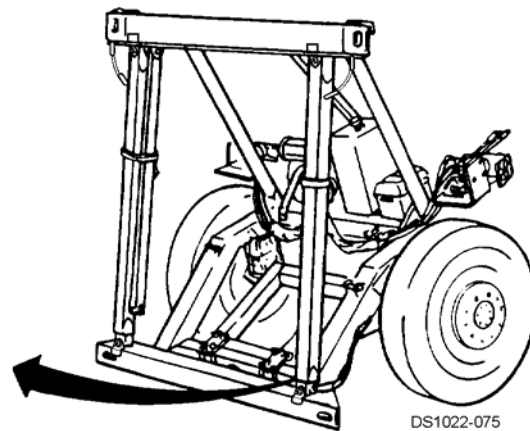
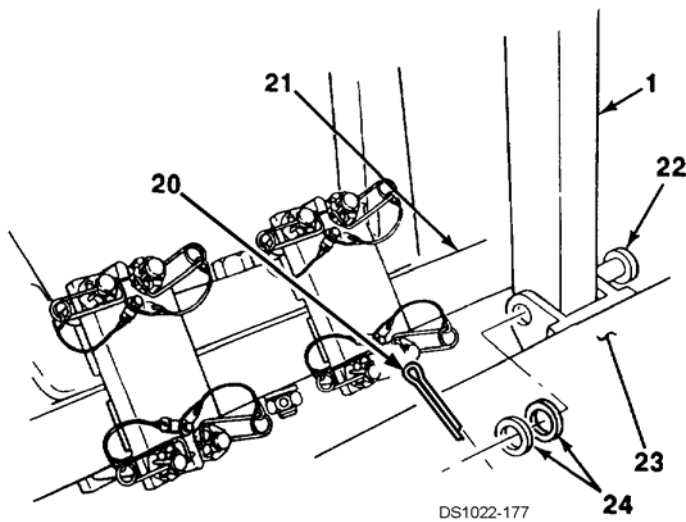


## 5-5. SUSPENSION LINK REPLACEMENT (Cont).

### NOTE

**Note quantity of flatwasher removed to aid in installation.**

9. Remove cotter pin (20), flatwasher (24), clevis pin (22), and suspension link (1) from pivot axle bracket (21) and bottom beam (23). Discard cotter pin.
10. Remove data plate(s) from suspension link (see paragraph 4-105).
11. Remove pivoting tray lower bracket (see paragraph 4-98) and hitch pin lanyard assembly (see paragraph 4-99).



### b. INSTALLATION

1. Install pivoting tray lower bracket (see paragraph 4-98) and hitch pin lanyard assembly (see paragraph 4-99).
2. Install data plate(s) on suspension link (see paragraph 4-105).
3. Support suspension link (1) with a suitable lifting device.

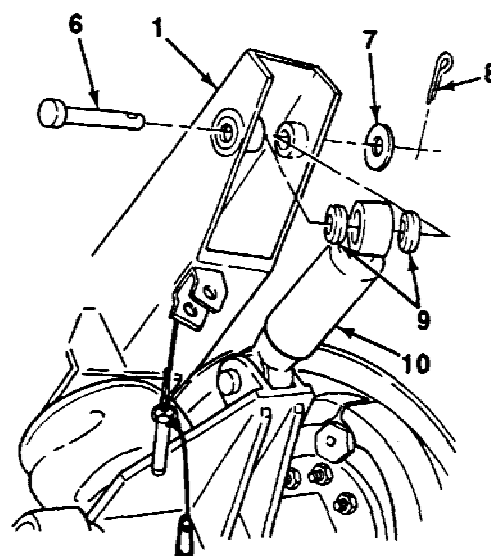
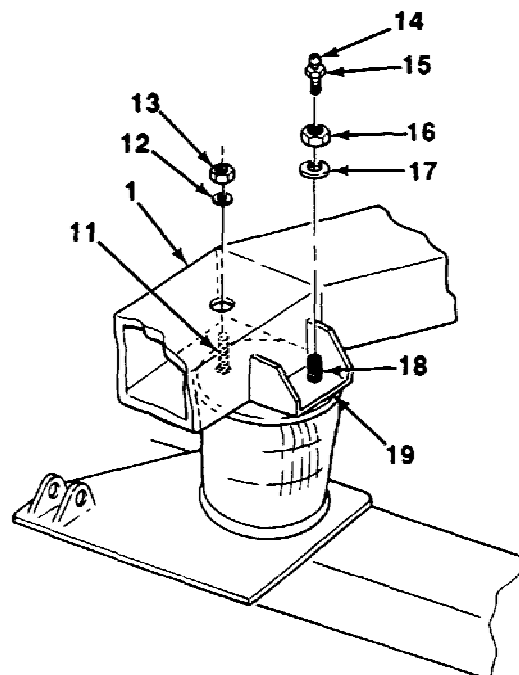
### NOTE

**An equal quantity of flatwashers must be installed on each side of reduce to a minimum the gap between suspension link and bottom beam pivot area.**

4. Apply grease to clevis pin (22). Install suspension link (1) on pivot axle bracket (21) and bottom beam (23) with clevis pin, flatwasher (24) and new cotter pin (20).

## 5-5. SUSPENSION LINK REPLACEMENT (Cont).

5. Lower suspension link (1) until studs (11 and 18) are positioned through holes in suspension link mounting plate (19).
6. Install two flatwashers (12 and 17) and new locknuts (13 and 16) on studs (11 and 18). Torque locknuts to 25 lb.-ft (34 N•m).
7. Install valve (15) on stud (18) with sealing compound (see paragraph 4-16) install cap (14) on valve.
8. If a front suspension link was removed, install brace (see paragraph 4-94).
9. If front or rear left side suspension link was removed, install hydraulic control valve bracket with associated components (see paragraph 4-93 or 4-96).
10. If front or rear right side suspension link was removed, install junction box bracket with associated components (see paragraph 4-92 or 4-95).
11. Install shock absorber (10) and two bushings (9) on suspension link (1) with clevis pin (6) flat-washer (7) and new cotter pin (8).



---

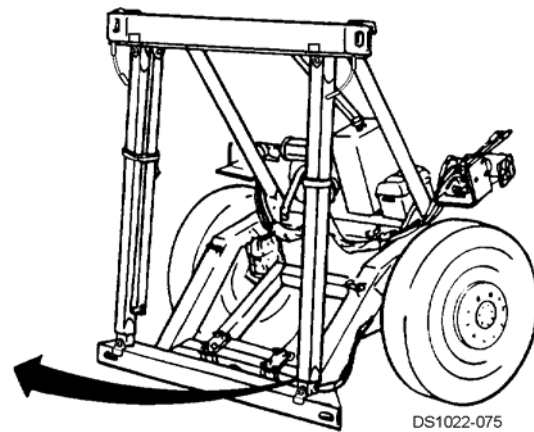
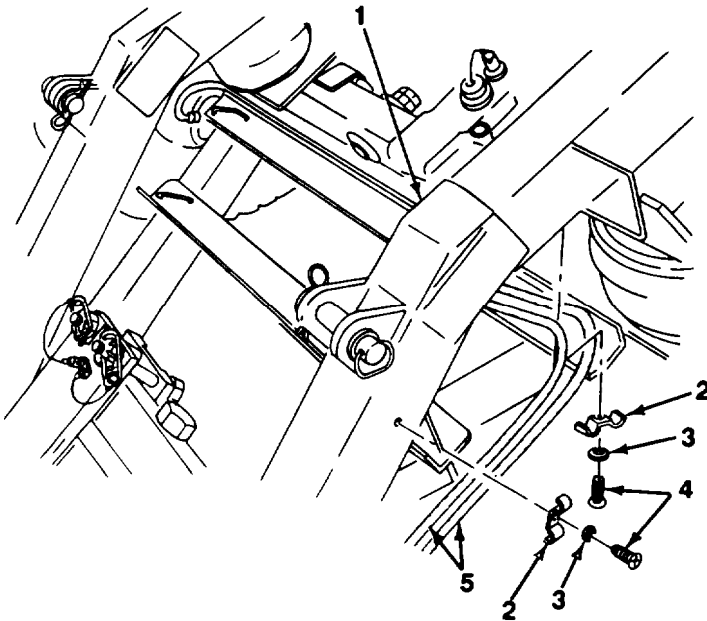
**5-5. SUSPENSION LINK REPLACEMENT (Cont).**

---

**NOTE**

**On right side, hose assemblies are secured to both side and underside of suspension link.**

12. Install two hydraulic hose assemblies (5) on suspension link (1) with hose clamp (2), flat washer (3), and self-tapping screw (4).



**Follow-on Tasks:**

- Install pivoting tray (see paragraph 4-80 or 4-81).
- Install hydraulic lift cylinder (see paragraph 4-110).

**Section IV. HYDRAULIC SYSTEM MAINTENANCE**

Paragraph Number	Paragraph Title	Page Number
5-6.	Hydraulic Control Valve Repair .....	5-15
5-7.	Hydraulic Lift Cylinder Repair (M1022A1 Without Side Lift Kit) .....	5-20
5-8	Hydraulic Positioning Cylinder Repair (M1022A1 Without Side Lift Kit) .....	5-25

**5-6. HYDRAULIC CONTROL VALVE REPAIR.**

This Task Covers:

- |                            |             |
|----------------------------|-------------|
| a. Disassembly             | C. Assembly |
| b. Cleaning and inspection |             |

Initial Setup:

Equipment Conditions:

- Hydraulic control valve removed (see paragraph 4-108).

Tools/Test Equipment:

- General mechanic's tool kit (item 30, Appendix G)
- Torque wrench, 0-200 lb.-in. (Item 41, Appendix G)

Materials/Parts:

- Sealing compound (Item 10, Appendix F)
- Hydraulic fluid (Item 15, Appendix F)
- Rags (Item 25, Appendix F)
- One seal kit
- Three tie-rod sets
- Handle kit (as required)

**CAUTION**

Maintain a clean work area when disassembling and assembling hydraulic control valve. Contamination from a dirty work area may cause damage to hydraulic components.

---

5-6. HYDRAULIC CONTROL VALVE REPAIR (Con't).

---

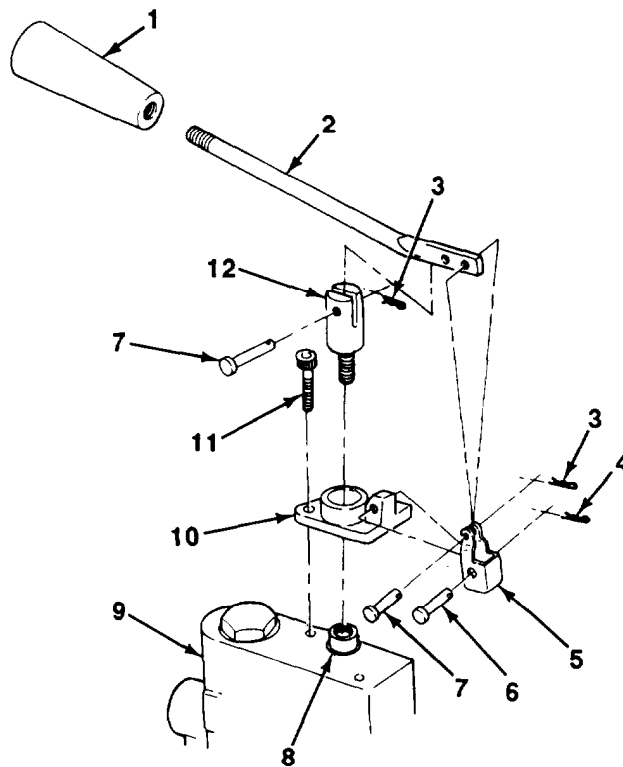
**a. DISASSEMBLY**

NOTE

● Steps 1 through 4 are performed the same way for the positioning cylinders work section and the lift cylinder work sections. Positioning cylinders work section is illustrated.

● All kit items and tie-rod set items should be discarded.

1. Remove two cotter pins (3), clevis pins (7), and handle (2) from link (5) and spool end adapter (12).
2. if damaged, remove knob (1) from handle (2).
3. Remove cotter pin (4), clevis pin (6), and link (5) from clevis (10).
4. If clevis (10) is damaged, remove two capscrews (11) and clevis from positioning cylinders work section (9). Remove spool end adapter (12) from spool valve (8).



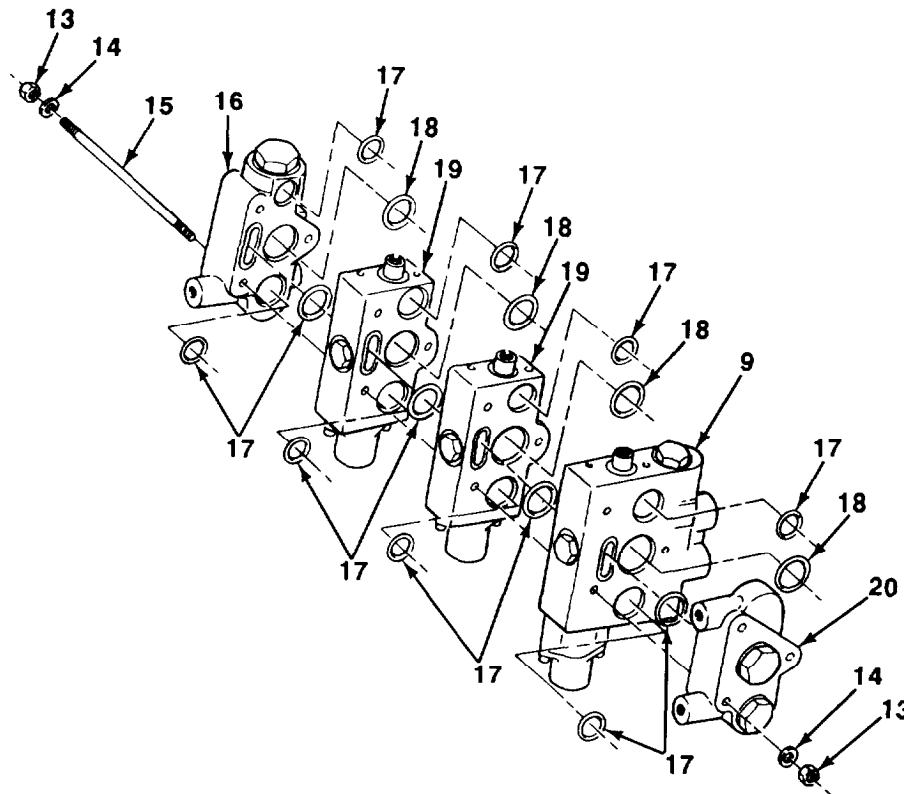


---

**5-6. HYDRAULIC CONTROL VALVE REPAIR (Con't).**


---

5. Remove six nuts (13), lockwashers (14), and three tie-rods (15) from hydraulic control valve.
6. Separate inlet section (16) and remove four preformed packings (17 and 18).
7. Separate two lift cylinder work sections (19) and eight preformed packings (17 and 18).
8. Separate positioning cylinders work section (9) and outlet section (20), and remove four preformed packings (17 and 18).


**b. CLEANING AND INSPECTION**

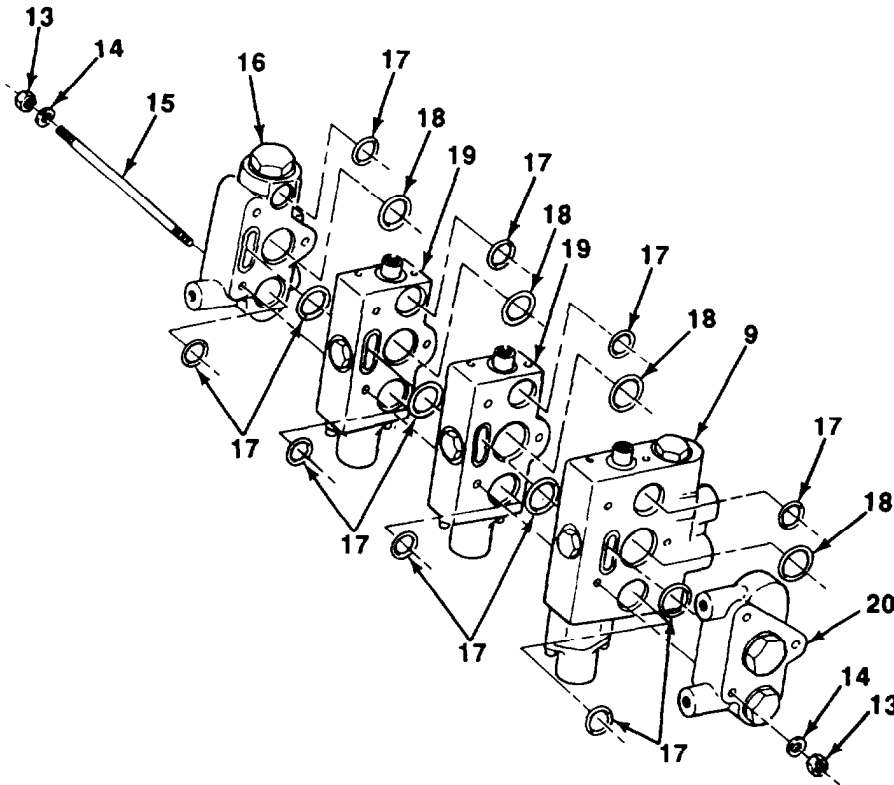
1. Clean all removed components with a clean rag.
2. inspect all removed components for cracks, breaks, bends, burrs, or other damage. Replace damaged components.

5-6. HYDRAULIC CONTROL VALVE REPAIR (Con't).

**c. ASSEMBLY**

NOTE

- Preformed packings should be lightly coated with hydraulic fluid before assembly.
  - All new kit items and new tie-rod set items should be used during assembly.
1. Assemble three new tie-rods (15) inlet section (16), four new preformed packings (17 and 18) two lift cylinder work sections (19), eight new preformed packings (17 and 18) positioning cylinders work section (9) four new preformed packings (17 and 18), and outlet section (20).
  2. Install six new lockwashers (14) and new nuts (13) on tie-rods (14). Torque nuts to 144-156 lb.-in. (16-18 N•m).



---

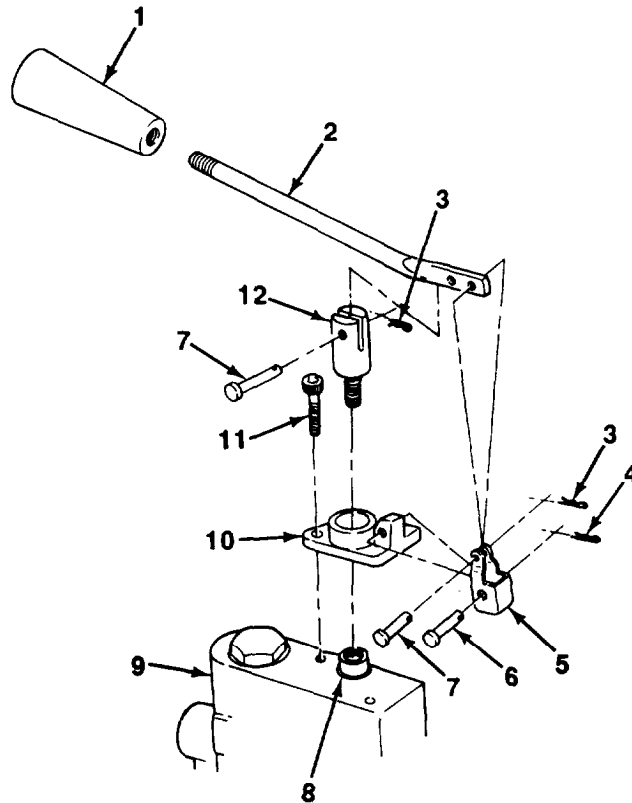
**5-6. HYDRAULIC CONTROL VALVE REPAIR (Con't).**


---

**NOTE**

Steps 3 through 6 are performed the same way for the positioning cylinders work section and the lift cylinder work sections. Positioning cylinders work section is illustrated.

3. If removed, install spool end adapter (12) on spool valve (8). Install clevis (10) on positioning cylinders work section (9) with two capscrews (11). Torque capscrews to 110-130 lb.-in. (12-15 N•m).
4. Install link (5) on clevis (10) with clevis pin (6) and cotter pin (4).
5. If removed, apply sealing compound on handle (2) and install knob (1).
6. Install handle (2) on link (5) and spool end adapter (12) with two clevis pins (7) and cotter pins (3).

**Follow-on Tasks:**

- Install hydraulic control valve (see paragraph 4-108).

---

**5-7. HYDRAULIC LIFT CYLINDER REPAIR (M1022A1 WITHOUT SIDE LIFT KIT).**

---

*This Task Covers:*

- |  |   |
|--|---|
| <ul style="list-style-type: none"> <li>a. Disassembly</li> <li>b. Cleaning and Inspection</li> </ul> | <ul style="list-style-type: none"> <li>c. Assembly</li> </ul> |
|--|---|
- 

*Initial Setup:*

**Equipment Conditions:**

- Hydraulic lift cylinder removed (see paragraph 4-110).

**Tools/Test Equipment:**

- General mechanic's tool kit (item 30, Appendix G)
- Compressor unit (Item 4, Appendix G)
- Machinist's vise (Item 36, Appendix G)
- Adjustable wrench (Item 37, Appendix G)
- Pipe strap wrench (Item 40, Appendix G)

**Personnel Required:** Two

**Materials/Parts:**

- Hydraulic fluid (Item 15, Appendix F)
- Rags (Item 25, Appendix F)
- Dry cleaning solvent (Item 27, Appendix F)
- One locknut
- One seal kit

**General Safety instructions:**

- Dry cleaning solvent is flammable and must not be used near an open flame. Use only in a well-ventilated area.
  - Compressed air used for cleaning purposes should never exceed 30 psi (207 kPa).
- 

**CAUTION**

Maintain a clean work area when disassembling and assembling hydraulic lift cylinder. Contamination from a dirty work area may cause damage to hydraulic components.

**a. DISASSEMBLY**

**NOTE**

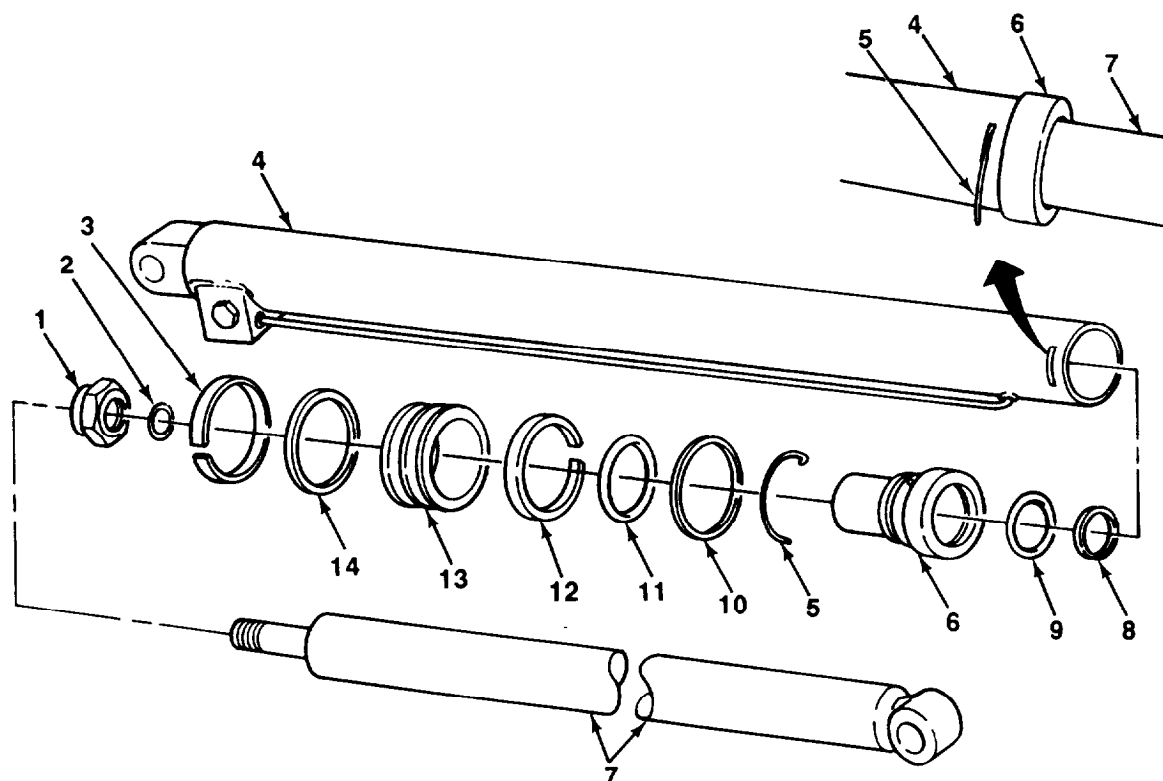
- A suitable container should be used to catch any draining hydraulic fluid. Ensure that spills are properly cleaned.
- As components are removed, they should be set aside and arranged in disassembly order to aid during assembly.

1. Drain all hydraulic fluid from lift cylinder.
2. Place barrel assembly (4) in vise.
3. Rotate head (6) counterclockwise. Remove lockwire (5), preformed packing (11), and head from barrel assembly (4). Slide head back on rod assembly (7). Discard preformed packing.
4. Remove rod assembly (7) with assembled components from barrel assembly (4).
5. Remove barrel assembly (4) from vise.

---

**5-7. HYDRAULIC LIFT CYLINDER REPAIR (M1022A1 WITHOUT SIDE LIFT KIT) (Con't).**


---



<b>CAUTION</b>
----------------

**DO NOT** damage machined surface of rod assembly when placing rod assembly in vise.

6. Place rod end of rod assembly (7) in vise.
7. Remove locknut (1) piston (13) with assembled components, and preformed packing (2) from rod assembly (7). Discard locknut and preformed packing.
8. Remove head (6) with assembled components from rod assembly (7).
9. Remove two wear rings (3 and 12) and seal (14) from piston (13). Discard wear rings and seal.
10. Remove backup seal (10), rod seal (9), and rod wiper (8) from head (6). Discard backup seal, rod seal, and rod wiper.

---

5-7. HYDRAULIC LIFT CYLINDER REPAIR (M1022A1 WITHOUT SIDE LIFT KIT) (Con't).

---

**b. CLEANING AND INSPECTION**



- Dry cleaning solvent, P-D-680, is toxic and flammable. Always wear protective goggles and gloves, and use only in a well-ventilated area. Avoid contact with skin, eyes, and clothes, and DO NOT breathe vapors. DO NOT use near open flame or excessive heat. The solvent's flash point is 100°F-138°F (38°C-59°C). If you become dizzy while using cleaning solvent, immediately get fresh air and medical help. If solvent contacts eyes, immediately wash your eyes and seek medical attention.
- Compressed air used for cleaning or drying purposes, or for clearing restrictions, should never exceed 30 psi (207 kPa). Wear protective clothing (goggles/shield, gloves, etc.) and use caution to avoid injury to personnel.

1. Clean all removed parts with dry cleaning solvent and dry with compressed air.
2. Inspect all components for cracks, breaks, bends, or corrosion. Inspect threaded parts for damaged threads. Replace damaged components.
3. Inspect barrel assembly and rod assembly for scoring, pits, corrosion, or burrs. Replace damaged components.

**c. ASSEMBLY**

**NOTE**

Preformed packings, seals, wear rings, rod wiper, rod seal, and lockwire should be lightly coated with hydraulic fluid before assembly.

1. Assemble new rod seal (9) and new rod wiper (8) on head (6).

**CAUTION**

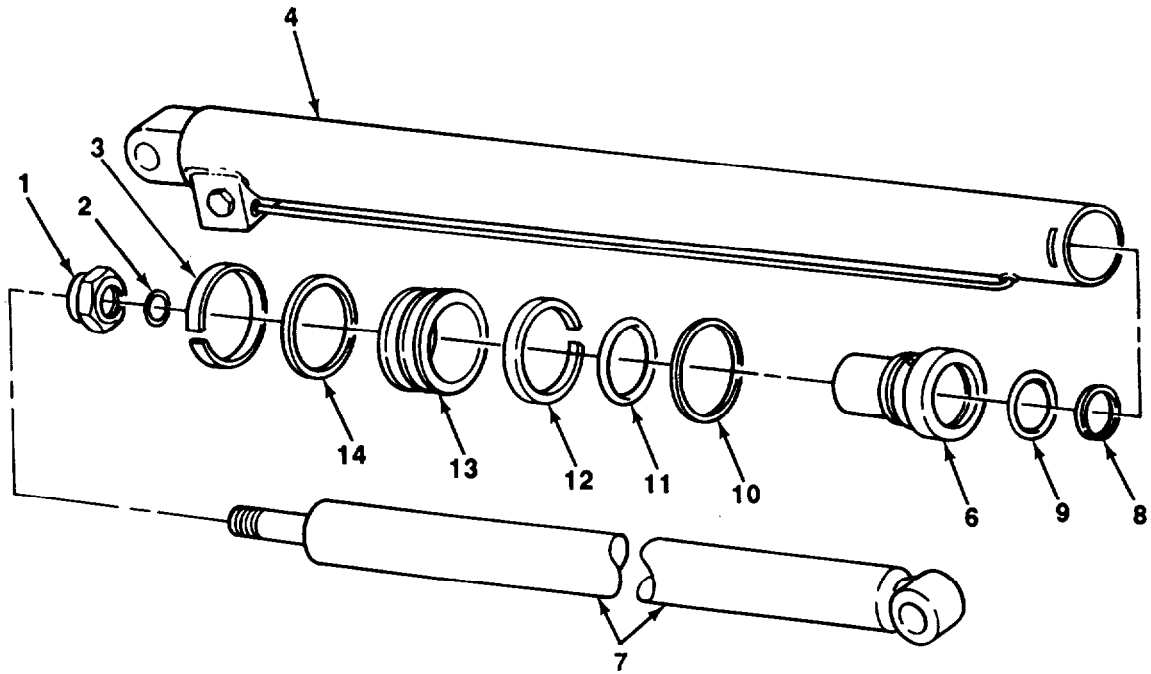
DO NOT damage machined surface of rod assembly when placing rod assembly in vise.

2. Place rod end of rod assembly (7) in vise.
3. Cant head (6) and position at rod assembly (7) with lip of rod wiper (8) started on shoulder of rod assembly. Twist head, maintaining canted position, and slide head onto rod assembly until lip of rod wiper is fully installed. Push head straight onto rod assembly.
4. Install new backup seal (10) and new preformed packing (11) in rear groove of head (8).

---

**5-7. HYDRAULIC LIFT CYLINDER REPAIR (M1022A1 WITHOUT SIDE LIFT KIT) (Con't).**


---



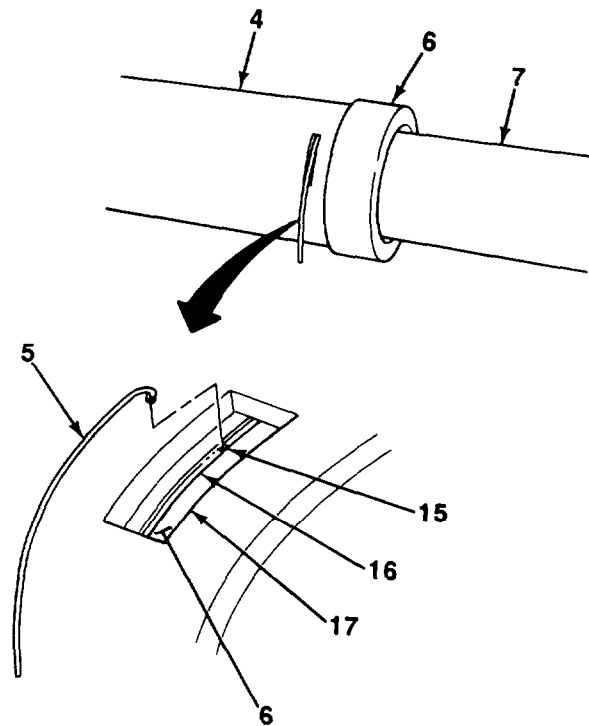
5. Install new preformed packing (2) on rod assembly (7).
6. Assemble two new wear rings (3 and 12) and new seal (14) on piston (13). Position gaps of wear rings approximately 180° opposite each other.
7. Install piston (13) with assembled components on rod assembly (7).
8. Install new locknut (1) on rod assembly (7) and tighten securely.
9. Remove rod assembly (7) from vise. Install barrel assembly (4) in vise.

---

**5-7. HYDRAULIC LIFT CYLINDER REPAIR (M1022A1 WITHOUT SIDE LIFT KIT) (Con't).**

---

10. Install rod assembly (7) with assembled components in barrel assembly (4) until head (6) contacts barrel assembly. Rotate head until hole (15) in lockwire groove (16) is visible through slot (17) at end of barrel assembly.
11. Insert hooked end of lockwire (5) into hole (15). Rotate head (6) clockwise until lockwire fully seats in lockwire groove (16).



**Follow-on Tasks:**

- Install hydraulic lift cylinder (see paragraph 4-110).



---

## 5-8. HYDRAULIC POSITIONING CYLINDER REPAIR (M1022A1 WITHOUT SIDE LIFT KIT).

---

*This Task Covers:*

- |  |   |
|--|---|
| <ul style="list-style-type: none"> <li>a. Disassembly</li> <li>b. Cleaning and inspection</li> </ul> | <ul style="list-style-type: none"> <li>c. Assembly</li> </ul> |
|--|---|
- 

*Initial Setup:*

### Equipment Conditions:

- Hydraulic positioning cylinder removed (see paragraph 4-83).

### Tools/Test Equipment:

- General mechanic's tool kit (Item 30, Appendix G)
- Compressor unit (Item 4, Appendix G)
- Machinist's vise (Item 36, Appendix G)
- Adjustable wrench (Item 37, Appendix G)
- Pipe strap wrench (Item 40, Appendix G)

**Personnel Required:** Two

### Materials/Parts:

- Hydraulic fluid (Item 15, Appendix F)
- Rags (Item 25, Appendix F)
- Dry cleaning solvent (Item 27, Appendix F)
- One locknut
- One seal kit

### General Safety instructions:

- Dry cleaning solvent is flammable and must not be used near an open flame. Use only in a well-ventilated area.
  - Compressed air used for cleaning purposes should never exceed 30 psi (207 kPa).
- 

**CAUTION**

Maintain a clean work area when disassembling and assembling hydraulic positioning cylinder. Contamination from a dirty work area may cause damage to hydraulic components.

**a. DISASSEMBLY**

### NOTE

- A suitable container should be used to catch any draining hydraulic fluid. Ensure that spills are properly cleaned.
- As components are removed, they should be set aside and arranged in disassembly order to aid during assembly.

1. Drain all hydraulic fluid from positioning cylinder.

---

## 5-8. HYDRAULIC POSITIONING CYLINDER REPAIR (M1022A1 WITHOUT SIDE LIFT KIT) (Con't).

---

2. Place barrel assembly (4) in vise.
3. Rotate head (7) counterclockwise. Remove lockwire (6), preformed packing (12), and head from barrel assembly (4). Slide head back on rod assembly (8). Discard preformed packing.
4. Remove rod assembly (8) with assembled components from barrel assembly (4).
5. Remove barrel assembly (4) from vise.

### CAUTION

**DO NOT** damage machined surface of rod assembly when placing rod assembly in vise.

6. Place rod end of rod assembly (8) in vise.
7. Remove locknut (1) and piston (14) with assembled components from rod assembly (8). Discard locknut.
8. Remove preformed packing (2) from rod assembly (8). Discard preformed packing.
9. Remove two stop tubes (5) and head (7) with assembled components from rod assembly (8).
10. Remove two wear rings (3 and 13), seal (16), and preformed packing (15) from piston (14). Discard wear rings, preformed packing, and seal.
11. Remove backup seal (11), rod seal (10), and rod wiper (9) from head (7). Discard backup seal, rod seal, and rod wiper.

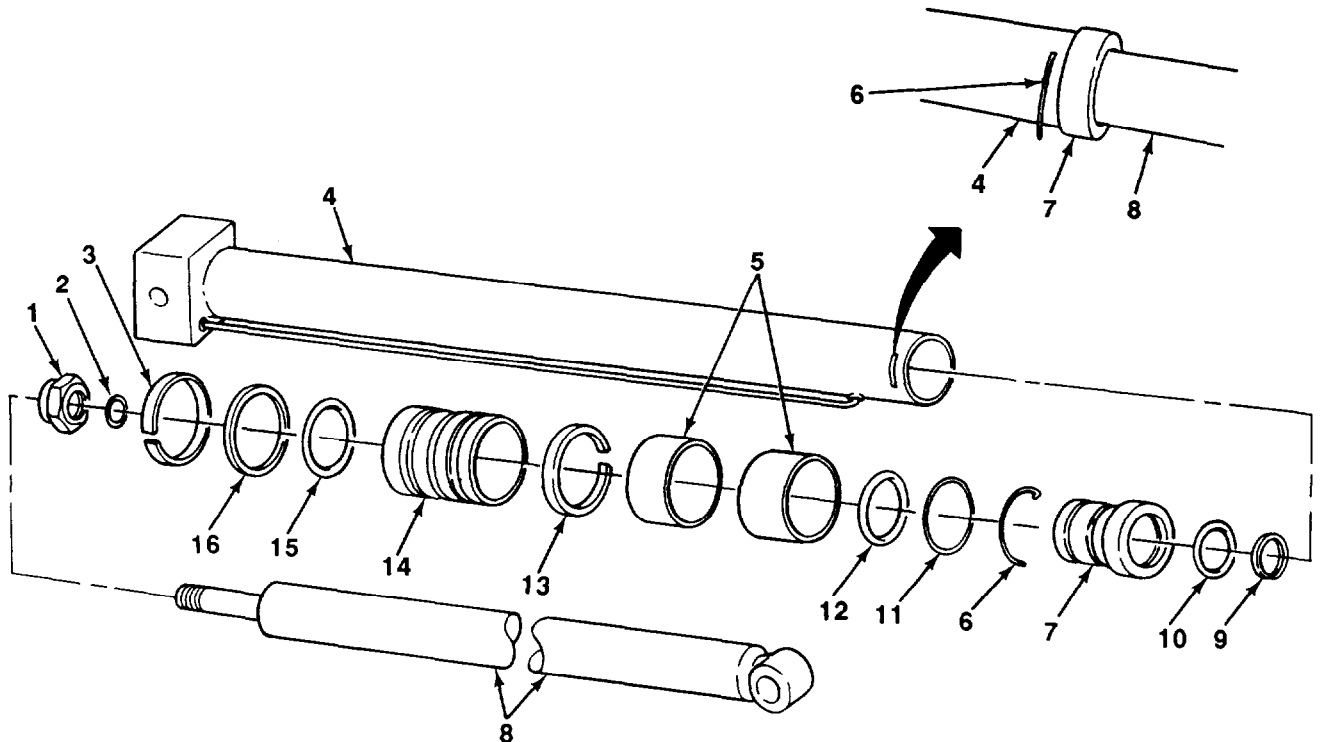
### b. CLEANING AND INSPECTION



- Dry cleaning solvent, P-D-680, is toxic and flammable. Always wear protective goggles and gloves, and use only in a well-ventilated area. Avoid contact with skin, eyes, and clothes, and **DO NOT** breathe vapors. **DO NOT** use near open flame or excessive heat. The solvent's flash point is 100°F-138°F (38°C-59°C). if you become dizzy while using cleaning solvent, immediately get fresh air and medical help. if solvent contacts eyes, immediately wash your eyes and seek medical attention.
- Compressed air used for cleaning or drying purposes, or for clearing restrictions, should never exceed 30 psi (207 kPa). Wear protective clothing (goggles/shield, gloves, etc.) and use caution to avoid injury to personnel.

1. Clean all removed pans with dry cleaning solvent and dry with compressed air.

5-8. HYDRAULIC POSITIONING CYLINDER REPAIR (M1022A1 WITHOUT SIDE LIFT KIT) (Con't).



2. Inspect all components for cracks, breaks, bends, or corrosion. Inspect threaded parts for damaged threads. Replace damaged components.
3. Inspect barrel assembly and rod assembly for scoring, pits, corrosion, or burrs. Replace damaged components.

**c. ASSEMBLY**

**NOTE**

Preformed packings, seals, rod wiper, rod seal, and lockwire should be lightly coated with hydraulic fluid before assembly.

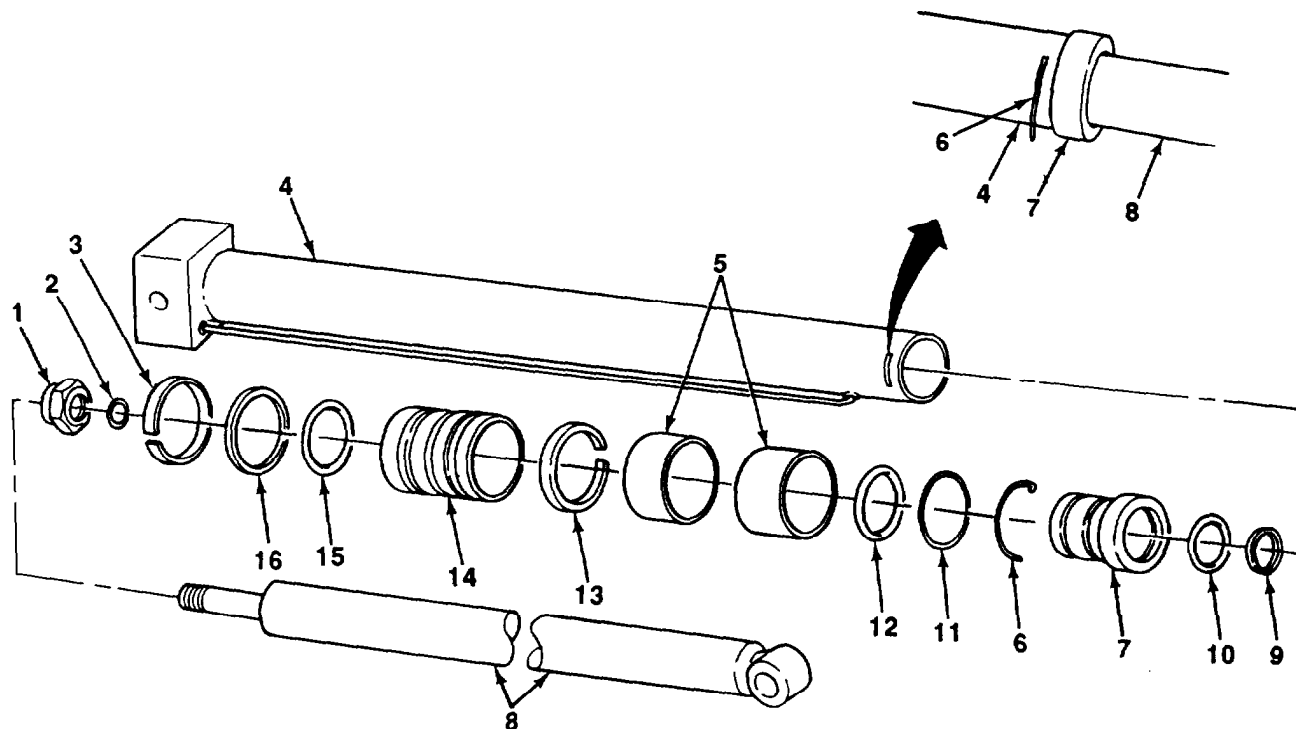
1. Assemble new rod seal (10) and rod wiper (9) on head (7).

5-8. HYDRAULIC POSITIONING CYLINDER REPAIR (M1022A1 WITHOUT SIDE LIFT KIT) (Con't).

**CAUTION**

DO NOT damage machined surface of rod assembly when placing rod assembly in vise.

2. Place rod end of rod assembly (8) in vise.
3. Cant head (7) and position at rod assembly (8) with lip of rod wiper (9) started on shoulder of rod assembly. Twist head, maintaining canted position, and slide head onto rod assembly until lip of rod wiper is fully installed. Push head straight onto rod assembly.
4. Install new backup seal (11) and new preformed packing (12) in rear groove of head (7).
5. Install new preformed packing (2) on rod assembly (8).
6. Install two stop tubes (5) on rod assembly (8).

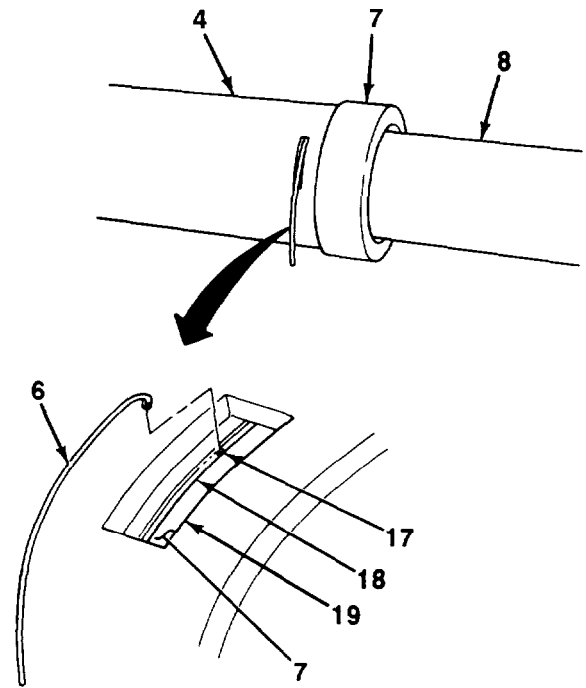


---

**5-8. HYDRAULIC POSITIONING CYLINDER REPAIR (M1022A1 WITHOUT SIDE LIFT KIT) (Con't).**


---

7. Assemble new preformed packing (15) new seal (16), and two new wear rings (3 and 13) on piston (14). Position gaps of wear rings approximately 180° opposite each other.
8. Install piston (14) with assembled components on rod assembly (8). Slide stop tubes (5) down on rod assembly until flush against piston.
9. Install new locknut (1) on rod assembly (8) and tighten securely.
10. Remove rod assembly (8) from vise. Install barrel assembly (4) In vise.
11. Install rod assembly (8) with assembled components In barrel assembly (4) until head (7) contacts barrel assembly. Rotate head until hole (17) in lockwire groove (18) is visible through slot (19) at end of barrel assembly.
12. Insert hooked end of lockwire (6) into hole (17). Rotate head (7) clockwise until lockwire fully seats in lockwire groove (18).


**Follow-on Tasks:**

- Install hydraulic positioning cylinder (see paragraph 4-83).



Section V. SPECIAL PURPOSE KITS MAINTENANCE

Paragraph Number	Paragraph Title	Page Number
5-9	Side Lift Kit Installation . . . . .	5-31
5-10	Hydraulic Lift Cylinder Repair (M1022Al With Side Lift Kit) . . . . .	5-34
5-11	Hydraulic Positioning Cylinder Repair (M1022Al With Side Lift Kit) . . . . .	5-48

**5-9. SIDE LIFT KIT INSTALLATION.**

*This Task Covers:* Installation

*initial Setup:*

**Tools/Test Equipment:**

**Personnel Required:** Three

- General mechanic's tool kit (Item 30, Appendix G)

**INSTALLATION**

**NOTE**

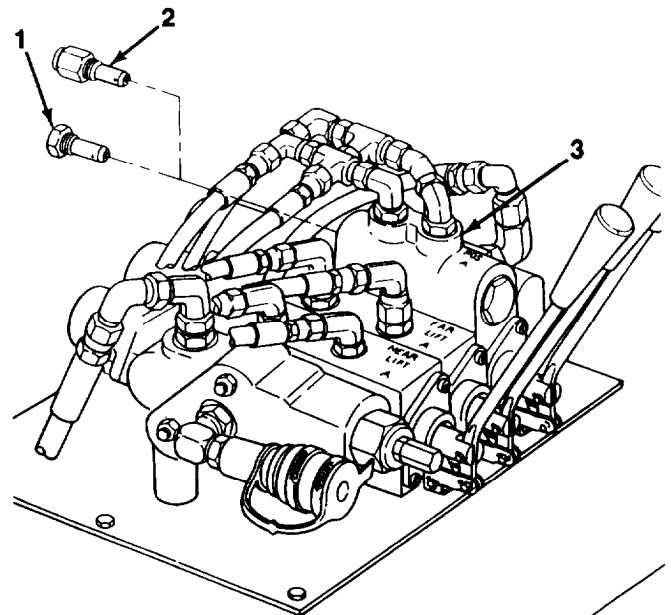
All components of ride lift kit are listed under Functional Group Code 33, Special Purpose Kits, in Appendix C of this manual.

1. Remove all side lift kit components from packing containers. Inspect for damage.
2. Check side lift kit items against packing slip to ensure that all components are present.

**NOTE**

Perform steps 3 through 8 on front and rear dollies.

3. Remove relief valve cartridge (2) from bottom of positioning cylinders work section (3) at hydraulic control valve. Install side lift kit relief plug (1).
4. Remove positioning cylinders and lift cylinders (see paragraphs 4-83 and 4-110).



---

**5-9. SIDE LIFT KIT INSTALLATION (Con't).**

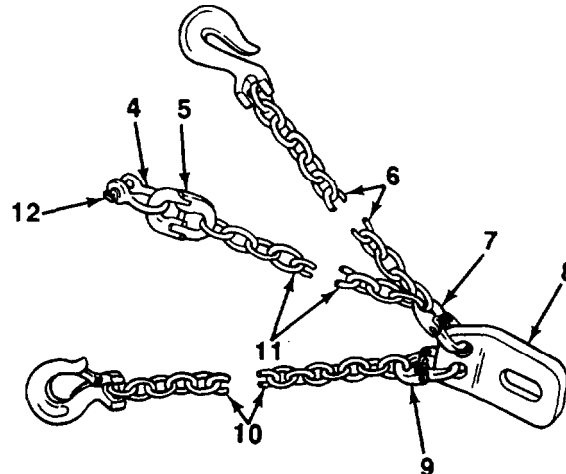
---

5. Install side lift kit positioning cylinders and lift cylinders (see paragraph 4-83 and 4-110).
6. Bleed hydraulic system (see paragraph 4-112).
7. Install lanyard assembly with detent pin in existing hole in top beam (see paragraph 4-99).
8. Install side lift kit data plates according to locations shown in paragraph 1-12 and instructions in paragraph 4-105.
9. Install storage box mounting brackets to front dolly axle (see paragraph 4-137).
10. Install storage box (see paragraph 4-138).

**NOTE**

Perform step 11 for each of four chain assemblies. Note that two chain assemblies will be used on left-hand side of shelter; two chain assemblies will be used on right-hand side of shelter.

11. Assemble chain assemblies:
  - (a) Install shackle (4) with pin (12) on detachable chain link (5) at one end of lifting chain (11).
  - (b) Install detachable chain links (7 and 9) on smaller holes of adapter (8).
  - (c) Install axle chain (10) on detachable chain link (9).
  - (d) Install lifting chain (11) and take-up chain (6) on detachable chain link (7).





---

**5-9. SIDE LIFT KIT INSTALLATION (Con't).**

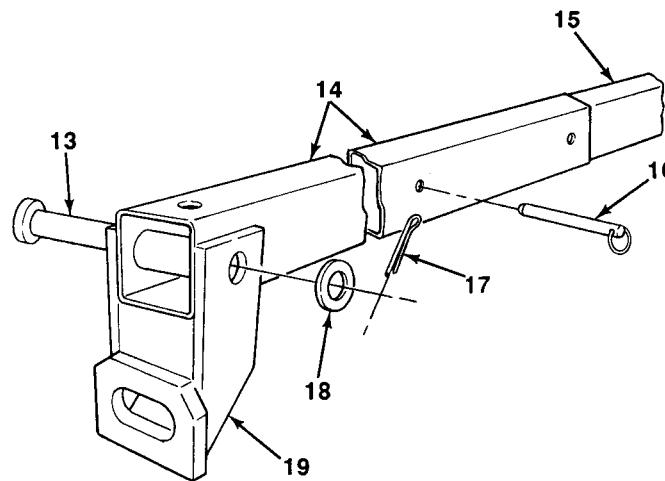

---

**NOTE**

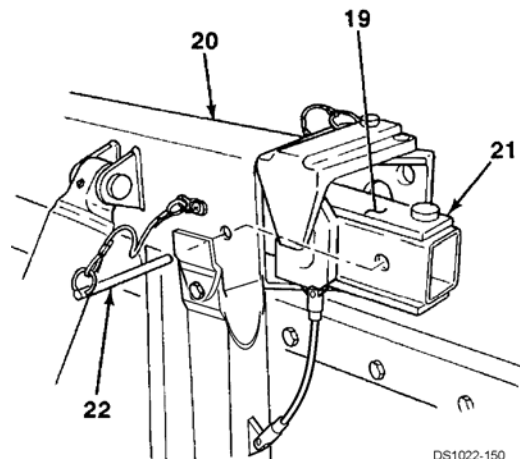
**Perform step 12 for each of two crossbrace assemblies.**

12. Assemble crossbrace assemblies:

- (a) Slide internal crossbrace (15) fully inside external crossbrace (14). Install detent pin (16) through internal and external crossbraces to secure.
- (b) At each end, install crossbrace bracket (19) with clevis pin (13), flat washer (18), and cotter pin (17). Fold crossbrace brackets over crossbrace assembly (21).



13. Stow crossbrace assembly (21) inside each top beam (20) and secure with detent pin (22).
14. Stow all side lift kit items in storage box.



DS1022-150

---

## 5-10. HYDRAULIC LIFT CYLINDER REPAIR (M1022A1 WITH SIDE LIFT KIT).

---

*This Task Covers:*

- a. Disassembly
- b. Cleaning and Inspection
- c. Assembly

---

*Initial Setup:*

### Equipment Conditions:

- Hydraulic lift cylinder removed (see paragraph 4-110)

### Tools/Test Equipment

- General mechanic's tool kit (Item 30, Appendix G)
- Compressor unit (Item 4, Appendix G)
- Compressed gas cylinder, acetylene (Item 6, Appendix G)
- Compressed gas cylinder, oxygen (Item 7, Appendix G)
- Rubber duplex hose (Item 10, Appendix G)
- Welder's gloves (Item 12, Appendix G)
- Industrial goggles (Item 13, Appendix G)
- Friction igniter (Item 15, Appendix G)
- Torch set (Item 31, Appendix G)
- Hand truck (Item 33, Appendix G)
- Fluid pressure regulating valve, acetylene (Item 34, Appendix G)
- Fluid pressure regulating valve, oxygen (Item 35, Appendix G)
- Machinist's vise (Item 36, Appendix G)
- Pipe strap wrench (Item 40, Appendix G)
- Torque wrench, 0-200 lb.-in. (Item 41, Appendix G)
- Suitable lifting device

### Materials/Parts:

- Sealing compound (Item 11, Appendix F)
- Hydraulic fluid (Item 15, Appendix F)
- Rags (Item 25, Appendix F)
- Dry cleaning solvent (Item 27, Appendix F)
- Masking tape, 1 in. width (Item 31, Appendix F)
- Nonelectrical wire (Item 34, Appendix F)
- One nylon lock
- One seal kit

**Personnel Required:** Two

### General Safety Instructions:

- Dry cleaning solvent is flammable and must not be used near an open flame. Use only in a well-ventilated area.
- Compressed air used for cleaning purposes should never exceed 30 psi (207 kPa).

---

**WARNING**

**Use extreme caution when handling heavy parts. Lifting device is required when parts weigh over 50 lb (23 kg) for a single person lift, over 100 lb (45 kg) for a two person lift, and over 150 lb (68 kg) for a three or more person lift. Keep clear of heavy parts supported only by lifting device. Failure to follow this warning may cause serious injury or death to personnel.**

**CAUTION**

**Maintain a clean work area when disassembling and assembling hydraulic lift cylinder. Contamination from a dirty work area may cause damage to hydraulic components.**

---

**5-10. HYDRAULIC LIFT CYLINDER REPAIR (M1022A1 WITH SIDE LIFT KIT) (Con't).**


---



---

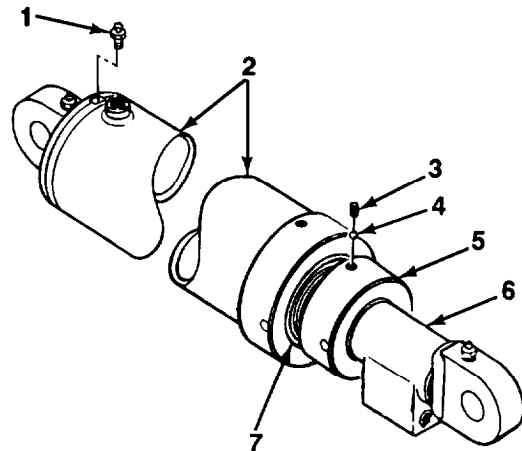
**a. DISASSEMBLY**


---

**NOTE**

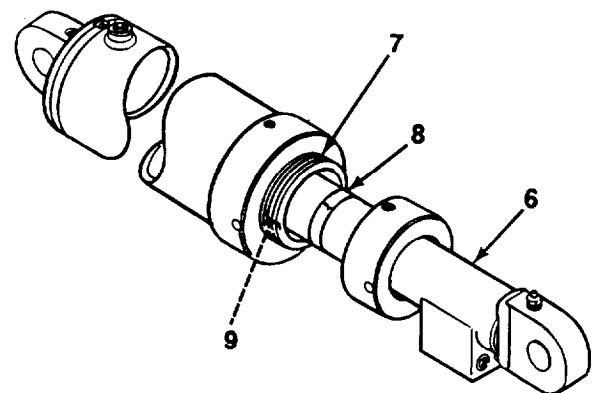
- A suitable container should be used to catch any draining hydraulic fluid. Ensure that spills are properly cleaned.
- As components are removed, they should be set aside and arranged in disassembly order to aid during assembly.

1. Remove air bleeder (1) from butt and tube assembly (2).
2. Drain all hydraulic fluid from lift cylinder.
3. Starting with smaller stage, remove setscrew (3) and nylon lock (4) from gland cap (5). Discard nylon lock.
4. Remove gland cap (5) from piston tube (7). Slide back gland cap on piston tube assembly (6).

**NOTE**

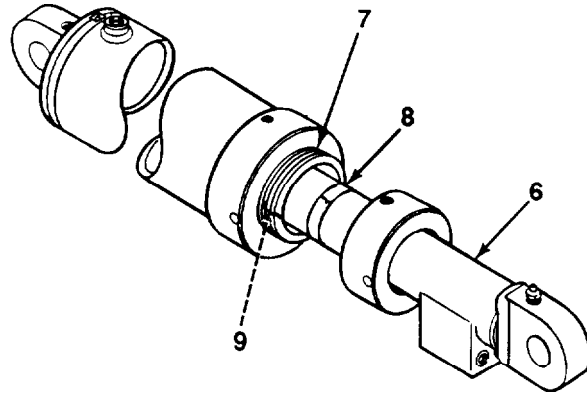
Layer(s) of masking tape wrapped around piston tube assembly is used to pull out packing set from inside inner surface of piston tube.

5. Pull out on piston tube assembly (6) about 4 in. (10 cm). Wrap one layer of masking tape (8) around piston tube assembly near end of piston tube (7).
6. Push in on piston tube assembly (6) so that masking tape (8) moves beyond packing set (9).



**5-10. HYDRAULIC LIFT CYLINDER REPAIR (M1022A1 WITH SIDE LIFT KIT) (Con't).**

7. Pull out on piston tube assembly (6) until packing set (9) is removed from piston tube (7).
8. If packing set (9) is not removed from piston tube (7), add additional layer(s) of masking tape (8) and repeat steps 6 and 7.

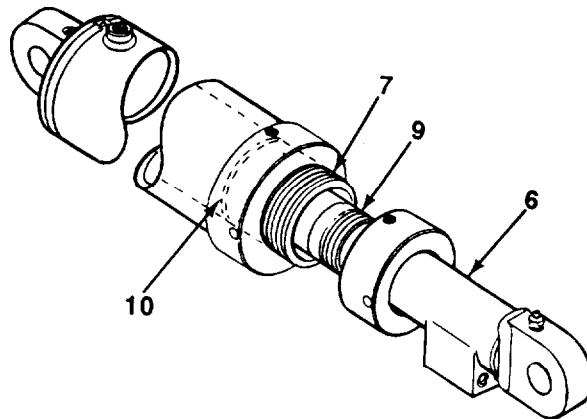


9. Slide back packing set (9) on piston tube assembly (6).

**NOTE**

**Round ring is seated in a groove on inner surface of piston tube.**

10. Locate tip of round ring (10).
11. Use rigid nonelectrical wire and form a loop end. Hook looped end to tip of round ring (10). Pull out on nonelectrical wire and remove round ring from groove on inner surface of piston tube (7).
12. Remove piston tube assembly (6) with assembled components from piston tube (7).



13. Remove two bearing rings (15) and three piston rings (16) from piston (14). Discard bearing rings and piston rings.



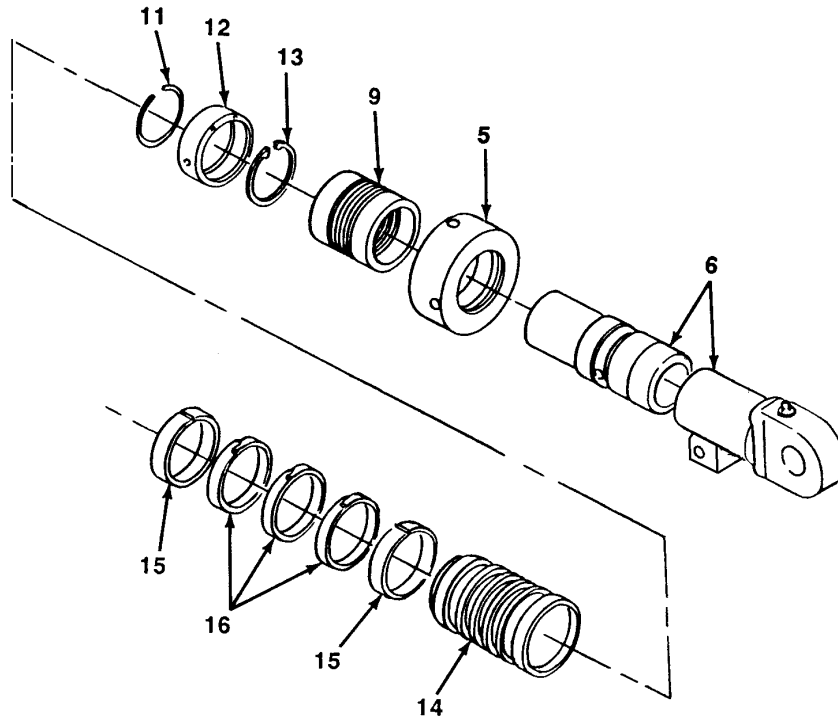
**Wear eye and hand protection and work in a well-ventilated area when using torch to heat piston. Failure to follow this warning may result in serious injury to personnel.**

14. Evenly apply heat to threaded area of piston (14) to loosen sealing compound bond between piston and piston tube assembly (6). Remove piston from piston tube assembly.

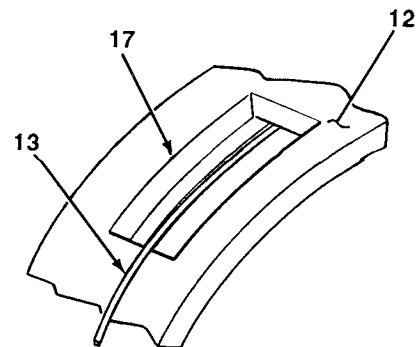
---

**5-10. HYDRAULIC LIFT CYLINDER REPAIR (M1022A1 WITH SIDE LIFT KIT) (Con't).**


---



1. Rotate stop ring (12) counterclockwise until end of square retaining ring (13) can be seen in milled slot (17). Reverse rotation of stop ring and back out square retaining ring through milled slot. If end of square retaining ring interferes with edge of milled slot, use a screwdriver to bend up square retaining ring to clear slot.
2. Rotate stop ring (12) one full turn and remove square retaining ring (13).



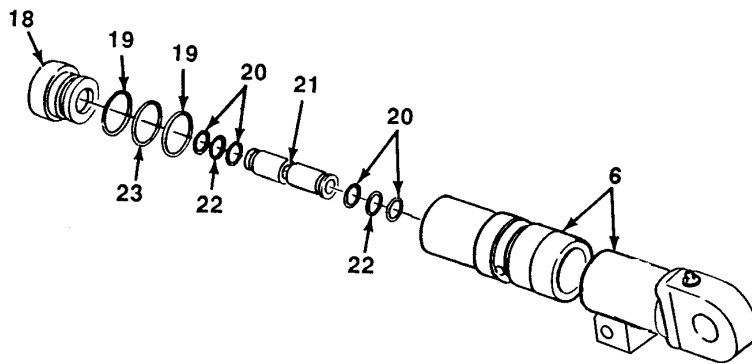
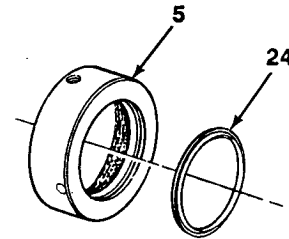
**CAUTION**

**Use caution not to score piston tube assembly.**

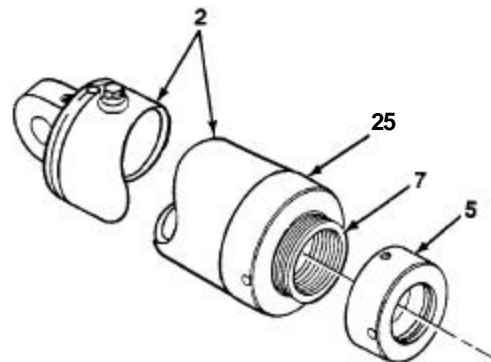
3. Slide stop ring (12) forward on piston tube assembly (6) and remove round ring (11).
4. Remove stop ring (12), packing set (9), and gland cap (5) from piston tube assembly (6). Discard packing set.

**5-10. HYDRAULIC LIFT CYLINDER REPAIR (M1022A1 WITH SIDE LIFT KIT) (Con't).**

5. Remove seal plate (18) and manifold tube (21) from piston tube assembly (6).
6. Remove wiper (24) from gland cap (5). Discard wiper.
7. Remove O-ring (23) and two backup washers (19) from seal plate (18). Discard O-rings and backup washers.
8. Remove two O-rings (22) and four backup washers (20) from manifold tube (21). Discard O-rings and backup washers.

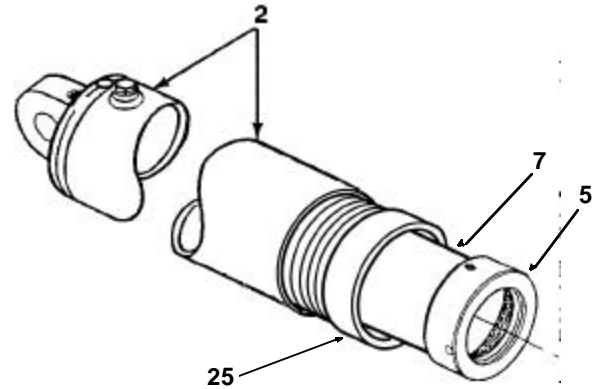


9. To aid in disassembly of larger stage, install gland cap (5) from smaller stage on piston tube (7).
10. Pull out on piston tube (7) about 4 in. (10 cm).
11. Remove gland (25) from butt and tube assembly (2) and slide gland onto piston tube (7).



## 5-10. HYDRAULIC LIFT CYLINDER REPAIR (M1022A1 WITH SIDE LIFT KIT) (Con't).

12. Remove piston tube (7) with assembled components from butt and tube assembly (2).
13. Remove gland cap (5) from piston tube (7).

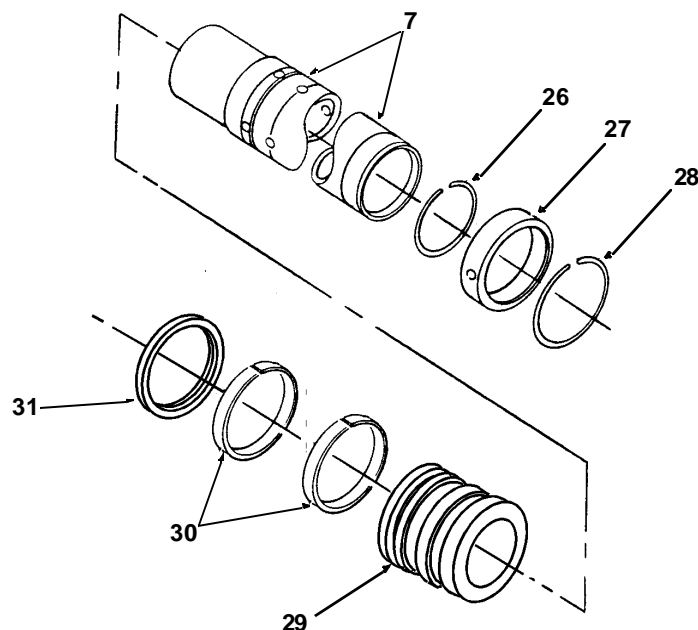


14. Remove teflon seal (31) and two bearing rings (30) from piston (29). Discard seal and bearing rings.

**WARNING**

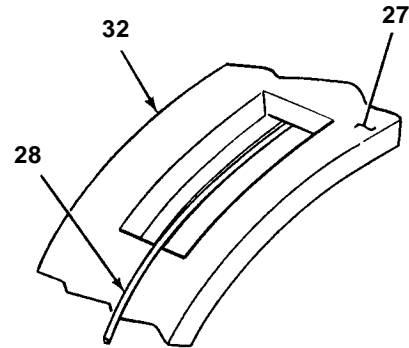
**Wear eye and hand protection and work in a well-ventilated area when using torch to heat piston. Failure to follow this warning may result in serious injury to personnel.**

15. Evenly apply heat to threaded area of piston (29) to loosen sealing compound bond between piston and piston tube (7). Remove piston from piston tube.



**5-10. HYDRAULIC LIFT CYLINDER REPAIR (M1022A1 WITH SIDE LIFT KIT) (Con't).**

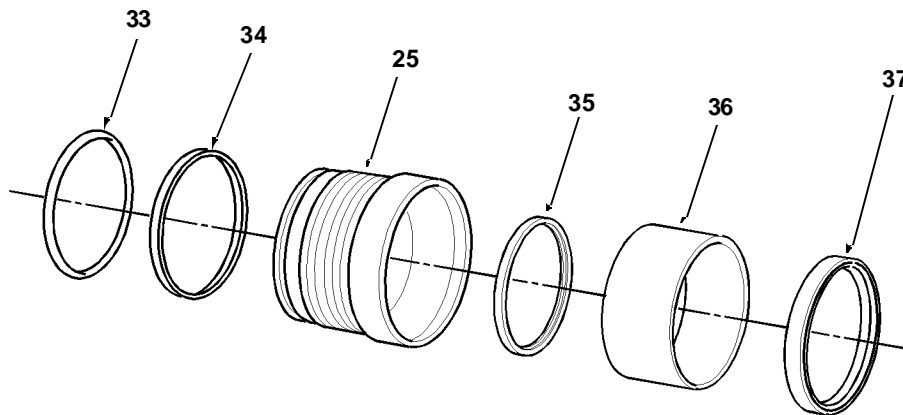
16. Rotate stop ring (27) counterclockwise until end of square retaining ring (28) can be seen in milled slot (32). Reverse rotation of stop ring and back out square retaining ring through milled slot. If end of square retaining ring interferes with edge of milled slot, use a screwdriver to bend up square retaining ring to clear slot.
17. Rotate stop ring (27) one full turn and remove square retaining ring (28).



**CAUTION**

**Use caution not to score piston tube.**

18. Slide stop ring (27) forward on piston tube (7) and remove round ring (26).
19. Remove stop ring (27) from piston tube (7).
20. Remove O-ring (33) and backup washer (34) from gland (25). Discard O-ring and backup washer.
21. Remove wiper (37), DU bushing (36), and T-seal (35) from gland (25). Discard wiper and T-seal.





## 5-10. HYDRAULIC LIFT CYLINDER REPAIR (M1022A1 WITH SIDE LIFT KIT) (Con't).

### a. CLEANING AND INSPECTION



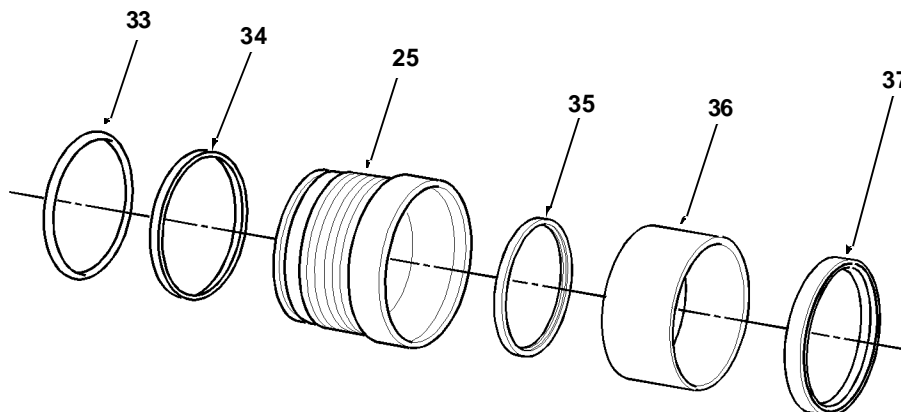
- Dry cleaning solvent, P-D-680, is toxic and flammable. Always wear protective goggles and gloves, and use only in a well-ventilated area. Avoid contact with skin, eyes, and clothes, and **DO NOT** breathe vapors. **DO NOT** use near open flame or excessive heat. The solvent's flash point is 100°F-138°F (38°C-59°C). If you become dizzy while using cleaning solvent, immediately get fresh air and medical help. If solvent contacts eyes, immediately wash your eyes and seek medical attention.
  - Compressed air used for cleaning or drying purposes, or for clearing restrictions, should never exceed 30 psi (207 kPa). Wear protective clothing (goggles/shield, gloves, etc.) and use caution to avoid injury to personnel.
1. Clean all removed parts with dry cleaning solvent. Ensure that all traces of sealing compound and masking tape have been removed. Dry thoroughly with compressed air.
  2. Inspect all components for cracks, breaks, bends, or corrosion. Inspect threaded parts for damaged threads. Replace damaged components.
  3. Inspect butt and tube assembly, piston tube, and piston tube assembly for scoring, pits, corrosion, or burrs. Replace damaged components.

### b. ASSEMBLY

#### NOTE

**All components should be lightly coated with hydraulic fluid before assembly.**

1. Starting with larger stage, install new backup washer (34) and new O-ring (33) to gland (25).
2. Install new T-seal (35), DU bushing (36), and new wiper (37) in gland (25).



---

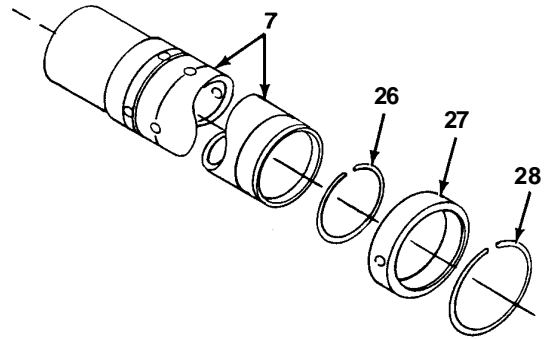
## 5-10. HYDRAULIC LIFT CYLINDER REPAIR (M1022A1 WITH SIDE LIFT KIT) (Con't).

---

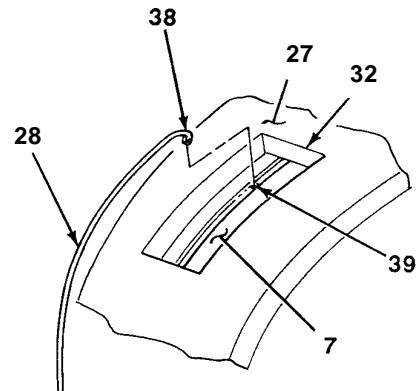
**CAUTION**

Use caution not to score piston tube.

3. Slide stop ring (27) onto piston tube (7).
4. Install round ring (26) in groove of piston tube (7).

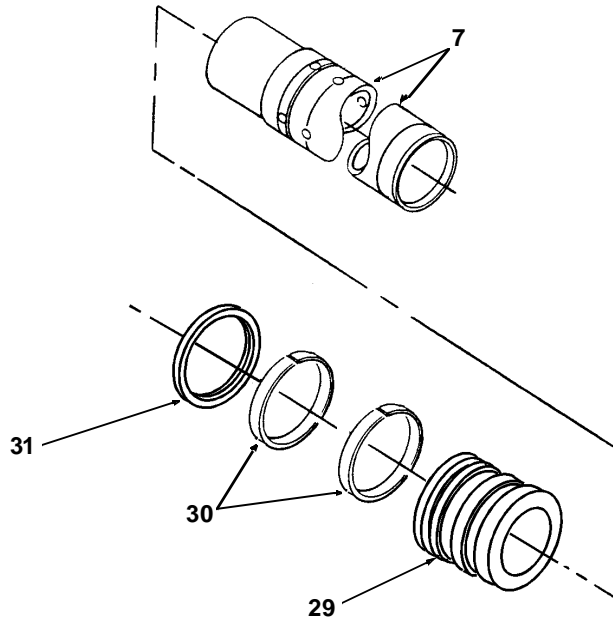


5. Slide stop ring (27) toward piston end until it contacts round ring (26). Rotate stop ring to ensure that milled slot (32) is aligned over hole (39) in piston tube (7).
6. Insert hooked end (38) of square retaining ring (28) into hole (39) of piston tube (7). Rotate stop ring (27) by hand as far as possible.
7. Rotate stop ring (27) one full turn. DO NOT allow hooked end (38) of square retaining ring (28) to pass under milled slot (32).
8. Hold down square retaining ring (28) and reverse rotation of stop ring (27). Rotate stop ring one half turn until milled slot (32) is opposite hole (39) of piston tube (7).

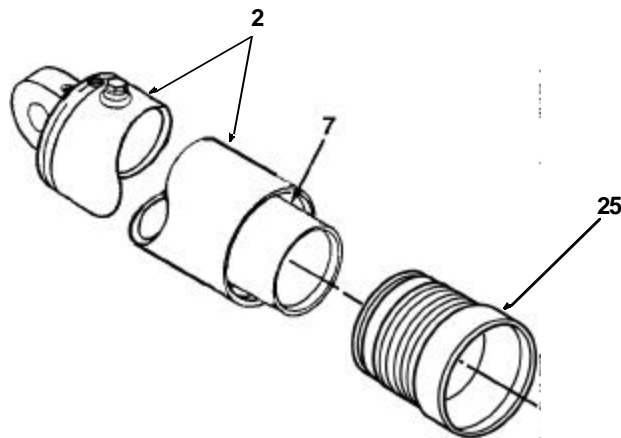


**5-10. HYDRAULIC LIFT CYLINDER REPAIR (M1022A1 WITH SIDE LIFT KIT) (Con't).**

9. Apply sealing compound to threads of piston (29). Install piston on piston tube (7).
10. Install two new bearing rings (30) and new teflon seal (31) on piston (29).



11. Slide piston tube (7) with assembled components into butt and tube assembly (2).

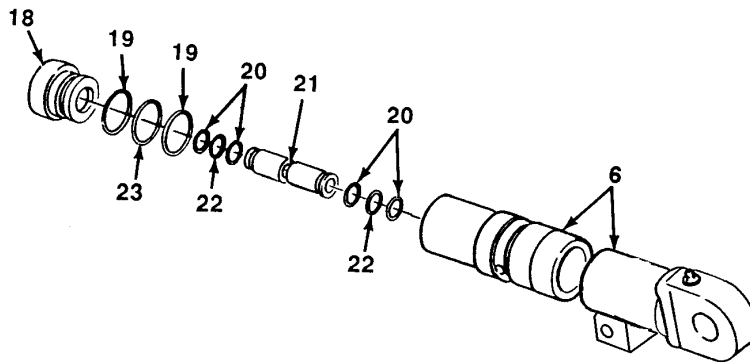


---

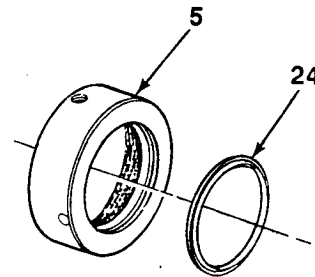
## 5-10. HYDRAULIC LIFT CYLINDER REPAIR (M1022A1 WITH SIDE LIFT KIT) (Con't).

---

12. Install gland (25) on butt and tube assembly (2) and tighten securely.
13. Continuing with smaller stage, install four new backup washers (20) and two new O-rings (22) on manifold tube (21).
14. Install two new backup washers (19) and new O-ring (23) to seal plate (18).



15. Install new wiper (24) to gland cap (5).
16. Install manifold tube (21) and seal plate (18) on piston tube assembly (6).

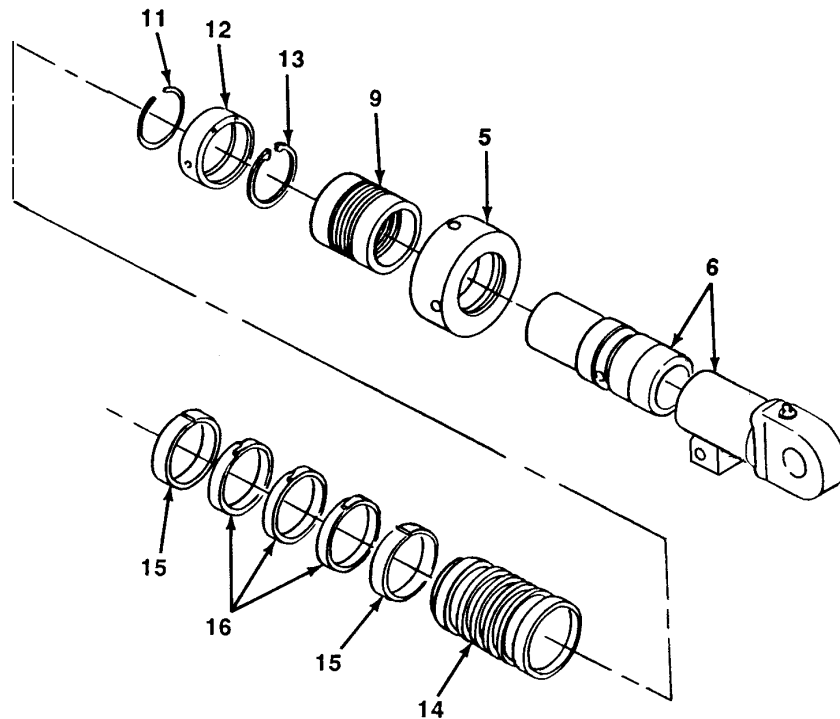


**5-10. HYDRAULIC LIFT CYLINDER REPAIR (M1022A1 WITH SIDE LIFT KIT) (Con't).**

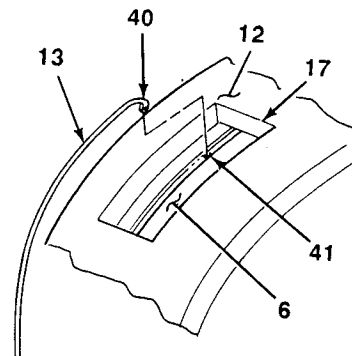
**CAUTION**

**Use caution not to score piston tube assembly.**

17. Slide gland cap (5), new packing set (9), round ring (10), and stop ring (12) onto piston tube assembly (6).
18. Install round ring (11) into groove of piston tube assembly (6).

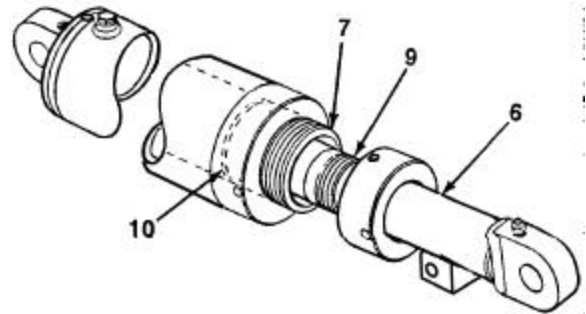


19. Slide stop ring (12) toward piston end until it contacts round ring (11). Rotate stop ring to ensure that milled slot (17) is alined over hole (41) in piston tube assembly (6).
20. Insert hooked end (40) of square retaining ring (13) into hole (41) of piston tube assembly (6). Rotate stop ring (12) by hand as far as possible.
21. Rotate stop ring (12) one full turn. DO NOT allow hooked end (40) of square retaining ring (13) to pass under milled slot (17).
22. Hold down square retaining ring (13) and reverse rotation of stop ring (12). Rotate stop ring one half turn until milled slot (17) is opposite hole (41) of piston tube assembly (6).

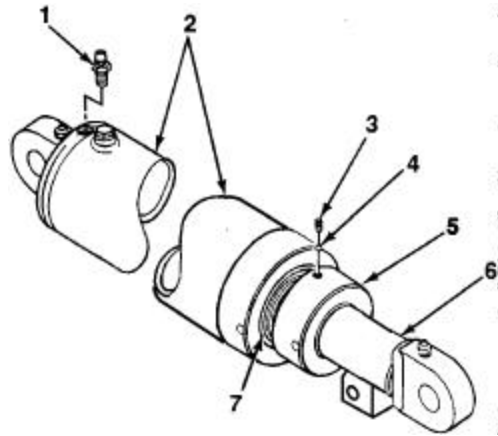


**5-10. HYDRAULIC LIFT CYLINDER REPAIR (M1022A1 WITH SIDE LIFT KIT) (Con't).**

23. Apply sealing compound to threads of piston (14). Install piston on piston tube assembly (6).
24. Install three new piston rings (16) and two new bearing rings (15) on piston (14).
25. Slide piston tube assembly (6) with assembled components into piston tube (7).
26. Slide round ring (10) down piston tube assembly (6) and seat in groove on inner surface of piston tube (7).
27. Slide packing set (9) down piston tube assembly (6) until it contacts round ring (10).



28. Install gland cap (5) on piston tube (7). Install new nylon lock (4) and setscrew (3) on gland cap.
29. Install air bleeder (1) on butt and tube assembly (2). Torque air bleeder to 180 lb.-in. (20 N•m).



**Follow-on Tasks:**

- Install hydraulic lift cylinder (see paragraph 4-110).

This Page Intentionally Left Blank.

---

## 5-11. HYDRAULIC POSITIONING CYLINDER REPAIR (M1022A1 WITH SIDE LIFT KIT).

---

*This Task Covers:*

- a. Disassembly
- b. Cleaning and Inspection
- c. Assembly

---

*Initial Setup:*

**Equipment Conditions:**

- Hydraulic positioning cylinder removed (see paragraph 4-83).

**Tools/Test Equipment:**

- General mechanic's tool kit (Item 30, Appendix G)
- Compressor unit (Item 4, Appendix G)
- Machinist's vise (Item 36, Appendix G)
- Adjustable wrench (Item 37, Appendix G)
- Pipe strap wrench (Item 40, Appendix G)

**Personnel Required:** Two

**Materials/Parts:**

- Hydraulic fluid (Item 15, Appendix F)
- Rags (Item 25, Appendix F)

**Materials/Parts (Con't):**

- Dry cleaning solvent (Item 27, Appendix F)
- One locknut
- One seal kit

**General Safety Instructions:**

- Dry cleaning solvent is flammable and must not be used near an open flame. Use only in a well-ventilated area.
- Compressed air used for cleaning purposes should never exceed 30 psi (207 kPa).

**CAUTION**

**Maintain a clean work area when disassembling and assembling hydraulic positioning cylinder. Contamination from a dirty work area may cause damage to hydraulic components.**

**a. DISASSEMBLY**

**NOTE**

- **A suitable container should be used to catch any draining hydraulic fluid. Ensure that spills are properly cleaned.**
- **As components are removed, they should be set aside and arranged in disassembly order to aid during assembly.**

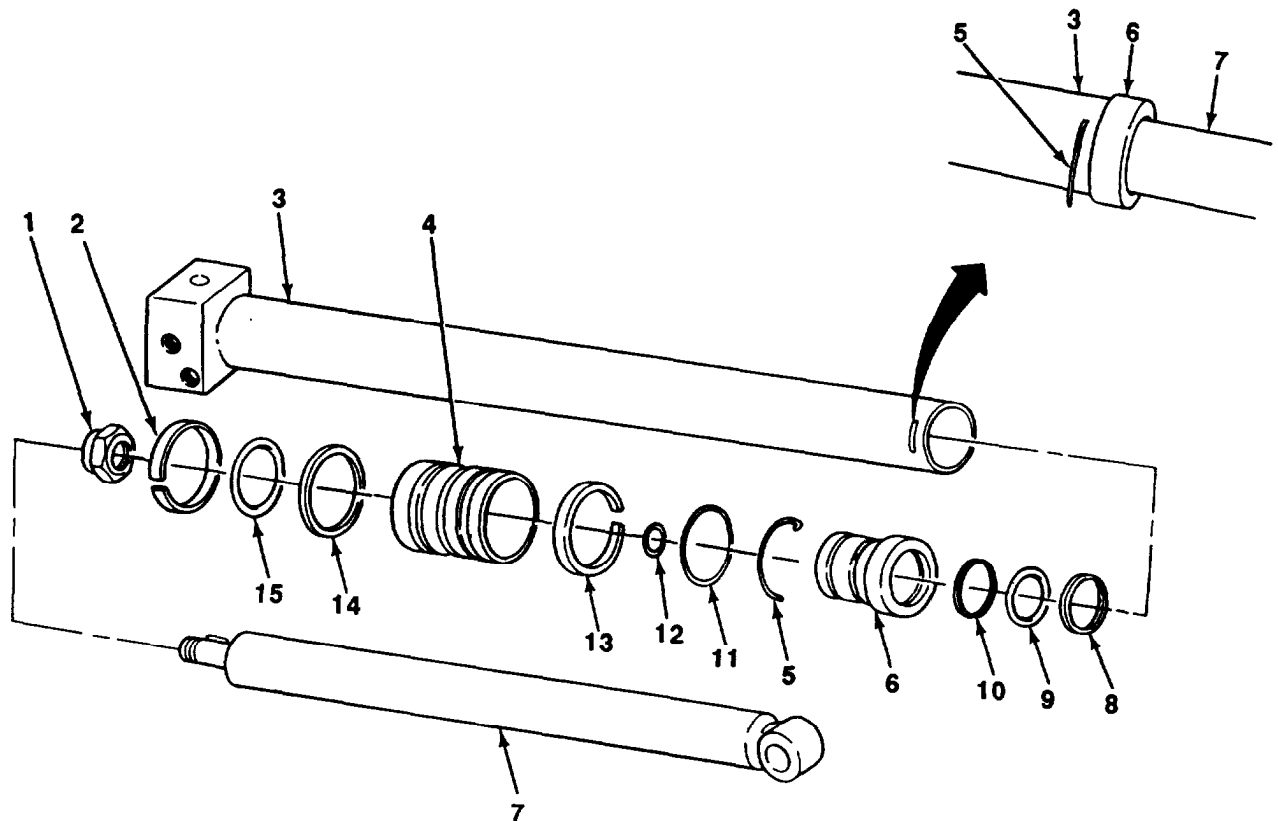
1. Drain all hydraulic fluid from positioning cylinder.
2. Place barrel assembly (3) in vise.
3. Rotate head (6) counterclockwise. Remove lockwire (5), O-ring (11), and head from barrel assembly (3) slide head back on rod assembly (7). Discard O-ring.
4. Remove rod assembly (7) with assembled components from barrel assembly (3).
5. Remove barrel assembly (3) from vise.



---

**5-11. HYDRAULIC POSITIONING CYLINDER REPAIR (M1022A1 WITH SIDE LIFT KIT)**  
**(Con't).**


---



**CAUTION**

**DO NOT** damage machined surface of rod assembly when placing rod assembly in vise.

6. Place rod end of rod assembly (7) in vise.
7. Remove locknut (1) piston (4) with assembled components, and O-ring (12) from rod assembly (7). Discard locknut and O-ring.
8. Remove head (6) with assembled components from rod assembly (7).
9. Remove two wear rings (2 and 13) seal (14) and expander (15) from piston (4). Discard wear rings, seal and expander.
10. Remove rod wiper (8) backup seal (9), and O-ring (10) from head (6). Discard rod wiper, backup seal, and O-ring.

---

5-11. HYDRAULIC POSITIONING CYLINDER REPAIR (M1022A1 WITH SIDE LIFT KIT)  
(Con't).

---

**b. CLEANING AND INSPECTION**



- Dry cleaning solvent, P-D-680, is toxic and flammable. Always wear protective goggles and gloves, and use only in a well-ventilated area. Avoid contact with skin, eyes, and clothes, and DO NOT breathe vapors. DO NOT use near open flame or excessive heat. The solvent's flash point is 100°F-138°F (38°C-59°C). If you become dizzy while using cleaning solvent, immediately get fresh air and medical help. If solvent contacts eyes, immediately wash your eyes and seek medical attention.
  - Compressed air used for cleaning or drying purposes, or for clearing restrictions, should never exceed 30 psi (207 kPa). Wear protective clothing (goggles/shield, gloves, etc.) and use caution to avoid injury to personnel.
1. Clean all removed parts with dry cleaning solvent and dry with compressed air.
  2. inspect all components for cracks, breaks, bends, or corrosion. inspect threaded parts for damaged threads. Replace damaged components.
  3. Inspect barrel assembly and rod assembly for scoring, pits, corrosion, or burrs. Replace damaged components.

**c. ASSEMBLY**

NOTE

Wear rings, O-rings, seals, rod wiper, and lockwire should be lightly coated with hydraulic fluid before assembly.

1. Assemble new O-ring (10), new backup seal (9) and new rod wiper (8) on head (6).

**CAUTION**

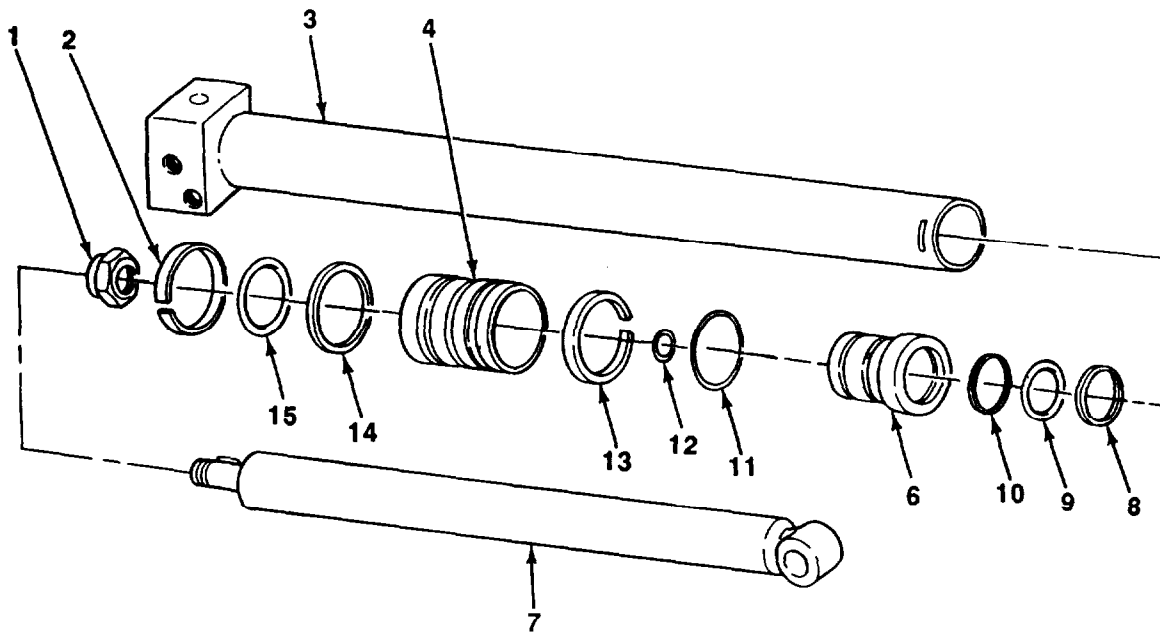
DO NOT damage machined surface of rod assembly when placing rod assembly in vise.

2. Place rod end of rod assembly (7) in vise.
3. Cant head (6) and position at rod assembly (7) with lip of rod wiper (8) started on shoulder of rod assembly. Twist head, maintaining canted position, and slide head onto rod assembly until lip of rod wiper is fully installed. Push head straight onto rod assembly.
4. install new O-ring (11) in rear groove of head (6).

---

**5-11. HYDRAULIC POSITIONING CYLINDER REPAIR (M1022A1 WITH SIDE LIFT KIT)**  
**(Con't).**

---



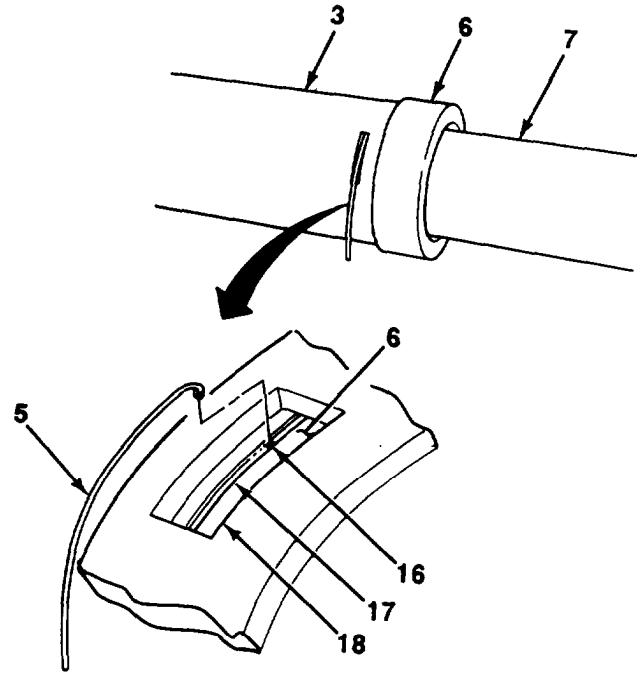
5. Install new O-ring (12) on rod assembly (7).
6. Assemble new expander (15) new seal (14), and two new wear rings (2 and 13) on piston (4). Position gaps of wear rings approximately 180° opposite each other.
7. Install piston (4) with assembled components on rod assembly (7).
8. Install new locknut (1) on rod assembly (7) and tighten securely.
9. Remove rod assembly (7) from vise. Install barrel assembly (3) in vise.

---

**5-11. HYDRAULIC POSITIONING CYLINDER REPAIR (M1022A1 WITH SIDE LIFT KIT)  
(Con't).**

---

10. Install rod assembly (7) with assembled components in barrel assembly (3) until head (6) contacts barrel assembly. Rotate head until hole (16) in lockwire groove (17) is visible through slot (18) at end of barrel assembly.
11. Insert hooked end of lockwire (5) into hole (16). Rotate head (6) clockwise until lockwire fully seats in lockwire groove (17).



**Follow-on Tasks:**

- Install hydraulic positioning cylinder (see paragraph 4-83).

**APPENDIX A  
REFERENCES**

**A-1. SCOPE.**

This appendix lists all forms, field manuals, technical bulletins, technical manuals, and other publications referenced in this manual which apply to the operation and Unit, Direct Support, and General Support Maintenance of the M1022A1 Dolly Set.

**A-2. PUBLICATION INDEX.**

DA Pam 25-30, *Consolidated Index of Army Publications and Blank Forms*, should be consulted frequently for latest changes or revisions and for new publications relating to materiel covered in this technical manual.

**A-3. FORMS.**

Refer to DA Pam 738-750, *The Army Maintenance Management System (TAMMS)*, for instructions on the use of maintenance forms.

Equipment inspection and Maintenance Worksheet .....	DA Form 2404
Equipment Log Assembly (Records) .....	DA Form 2408
Maintenance Request .....	DA Form 2407
Preventive Maintenance Schedule and Record .....	DD Form 314
Processing and Deprocessing Record for Shipment, Storage and issue of Vehicles and Spare Engines .....	DD Form 1397
Product Quality Deficiency Report .....	SF Form 368
Recommended Changes to Equipment Technical Publications .....	DA Form 2028-2
Recommended Changes to Publications and Blank Forms .....	DA Form 2028
Report of Discrepancy (ROD) .....	SF 364

**A-4. FIELD MANUALS.**

Army Motor Transport Units and Operations .....	FM 55-30
Basic Cold Weather Manual .....	FM 31-70
Camouflage .....	FM 20-3
Chemical and Biological Contamination Avoidance .....	FM 3-3
Desert Operations (How to Fight) .....	FM 90-3(HTF)
First Aid for Soldiers .....	FM 21-11

---

**A-4. FIELD MANUALS (Con't).**

---

Manual for the Wheeled Vehicle Driver .....	FM 21-305
NBC Decontamination .....	FM 3-5
NBC Protection .....	FM3-4
Northern Operations .....	FM 31-71
Operation and Maintenance of Ordnance Materiel in Cold Weather (0°F to -65°F) .....	FM 9-207
Railway Operating and Safety Rules .....	FM 55-21

---

**A-5. TECHNICAL BULLETINS.**

---

Color, Marking, and Camouflage Painting of Military Vehicles, Construction Equipment, and Materiel Handling Equipment .....	TB 43-0209
Warranty Program for Dolly Set: Lift, Transportable Shelter, 7½ Ton, M1022A1 (NSN 2330-01-378-9997) (EIC: CML) .....	TB 9-2330-390-12

---

**A-6. TECHNICAL MANUALS.**

---

Inspection, Care, and Maintenance of Antifriction Bearings .....	TM 9-214
Materials Used for Cleaning, Preserving, Abrading, and Cementing Ordnance Materiel and Related Items Including Chemicals .....	TM 9-247
Operator's Manual for Welding Theory and Application .....	TM 9-237
Operator's, Unit, Direct Support, and General Support Maintenance Manual for Care, Maintenance, Repair and Inspection of Pneumatic Tires and Inner Tubes .....	TM9-2610-20014
Operator's, Unit, intermediate Direct Support, and intermediate General Support Maintenance Manual for Lead-Acid Storage Batteries .....	TM 9-6140-200-14
Painting Instructions for Army Materiel .....	TM 43-0139
Procedures for Destruction of Tank-Automotive Equipment to Prevent Enemy Use (U.S. Army Tank-Automotive Command) .....	TM 750-244-6
Railcar Loading Procedures .....	TM 55-601
Storage and Materials Handling .....	TM 743-200-1

---

**A-7. OTHER PUBLICATIONS.**

---

Army Logistics Readiness and Sustainability .....	AR 700-138
Army Medical Department Expendable/Durable Items .....	CTA 8-100
Expendable/Durable Items (Except Medical, Class V, Repair Parts, and Heraldic Items) .....	CTA 50-970
Identification List (IL): FSG 9100, Fuels, Lubricants, Oils, and Waxes .....	FSG 9100

## APPENDIX B MAINTENANCE ALLOCATION CHART

---

### Section I. INTRODUCTION

---

#### B-1. GENERAL.

---

- a. This section provides a general explanation of all maintenance and repair functions authorized at the various maintenance levels.
  - b. The Maintenance Allocation Chart (MAC) in Section II designates overall authority and responsibility for the performance of maintenance functions on the identified end item or component. The application of the maintenance functions to the end item or component will be consistent with the capacities and capabilities of the designated maintenance levels.
  - c. Section III lists the tools and test equipment (both special tools and common tool sets) required for each maintenance function as referenced from Section II.
  - d. Section IV contains supplemental instructions and explanatory notes for a particular maintenance function.
- 

#### B-2. MAINTENANCE FUNCTIONS.

---

Maintenance functions will be limited to and defined as follows:

- a. **Inspect.** To determine the serviceability of an item by comparing its physical, mechanical, and/or electrical characteristics with established standards through examination (e.g., by sight, sound, or feel).
- b. **Test.** To verify serviceability by measuring the mechanical, pneumatic, hydraulic, or electrical characteristics of an item and comparing those characteristics with prescribed standards.
- c. **Service.** Operations required periodically to keep an item in proper operating condition [i.e., to clean (includes decontaminate, when required), to preserve, to drain, to paint, or to replenish fuel, lubricants, chemical fluids, or gases].
- d. **Adjust.** To maintain or regulate, within prescribed limits, by bringing into proper or exact position, or by setting the operating characteristics to specified parameters.
- e. **Aline.** To adjust specified variable elements of an item to bring about optimum or desired performance.
- f. **Calibrate.** To determine and cause corrections to be made or to be adjusted on instruments or test, measuring, and diagnostic equipments used in precision measurement. Consists of comparisons of two instruments, one of which is a certified standard of known accuracy, to detect and adjust any discrepancy in the accuracy of the instrument being compared.
- g. **Remove/Install.** To remove and install the same item when required to perform service or other maintenance functions. Install may be the act of emplacing, seating, or fixing into position a spare, repair part, or module (component or assembly) in a manner to allow the proper functioning of an equipment or system.

---

**B-2. MAINTENANCE FUNCTIONS (Con't).**

---

h. **Replace.** To remove an unserviceable item and Install a serviceable counterpart in its place. "Replace" is authorized by the MAC and is shown as the third position of the SMR code.

i. **Repair.** The application of maintenance services, including fault location/troubleshooting, removal/installation, and disassembly/assembly procedures and maintenance actions to Identify troubles and restore serviceability to an item by correcting specific damage, fault, malfunction, or failure in a part, subassembly, module (component or assembly), end item, or system.

j. **Overhaul.** That maintenance effort (service/action) prescribed to restore an item to a completely serviceable/operational condition as required by maintenance standards in appropriate technical publications (i.e., DMWR). Overhaul is normally the highest degree of maintenance performed by the Army. Overhaul does not normally return an item to like new condition.

k. **Rebuild.** Consists of those services/actions necessary for the restoration of unserviceable equipment to a like new condition in accordance with original manufacturing standards. Rebuild is the highest degree of materiel maintenance applied to Army equipment. The rebuild operation includes the act of returning to zero those age measurements (hours/miles, etc.) considered in classifying Army equipment/components.

---

**B-3. EXPLANATION OF COLUMNS IN THE MAC, SECTION II.**

---

a. **Column(1) - Group Number.** Column 1 lists functional group code numbers, the purpose of which is to identify maintenance significant components, assemblies, subassemblies, and modules with the next higher assembly. End item group number shall be "00."

b. **Column (2) - Component/Assembly.** Column 2 contains the names of components, assemblies, subassemblies, and modules for which maintenance is authorized.

c. **Column (3) - Maintenance Function.** Column 3 lists the functions to be performed on the item listed in Column 2. (For a detailed explanation of these functions, refer to paragraph B-2.)

d. **Column (4) - Maintenance Level.** Column 4 specifies, by the listing of a *work time* figure in me appropriate subcolumn (s) the level of maintenance authorized to perform the function listed in Column 3. This figure represents the active time required to perform that maintenance function at the indicated level of maintenance. The number or complexity of the tasks within the listed maintenance function vary at different maintenance levels, appropriate work time figures will be shown for each level. The work time figure represents the average time required to restore an Item (assembly, subassembly, component, module, end item, or system) to a serviceable condition under typical field operating conditions. This time includes preparation time (including any necessary disassembly/assembly time), troubleshooting/fault location time, and quality assurance/quality control time in addition to the time required to perform the specific tasks identified for the maintenance functions authorized in the Maintenance Allocation Chart. The symbol designations for the various maintenance levels are as follows:

- C . . . . Unit (Operator or Crew)
- O . . . . Unit Maintenance
- F . . . . Direct Support Maintenance
- H . . . . General Support Maintenance
- D . . . . Depot Maintenance

e. **Column (5) - Tools and Equipment.** Column 5 specifies, by code, those common tool sets (not individual tools) and special tools, TMDE, and support equipment required to perform the designated function..



**B-3. EXPLANATION OF COLUMNS IN THE MAC, SECTION II (Con't).**

a. **Column (6) - Remarks.** This column shall, when applicable, contain a letter code, in alphabetic order, which shall be keyed to the remarks contained in Section IV.

**B-4. EXPLANATION OF COLUMNS IN TOOL AND TEST EQUIPMENT REQUIREMENTS SECTION III.**

a. **Column (1) - Tool or Test Equipment Reference Code.** The tool and test equipment reference code correlates with a code used in the MAC, Section II, Column 5.

b. **Column (2) - Maintenance Level.** The lowest level of maintenance authorized to use the tool or test equipment.

c. **Column (3) - Nomenclature.** Name or identification of the tool or test equipment.

d. **Column (4) - National/NATO Stock Number.** The National or NATO Stock Number of the tool or test equipment.

e. **Column (5) - Tool Number.** The manufacturer's part number.

**B-1. EXPLANATION OF COLUMNS IN REMARKS, SECTION IV.**

a. **Column (1) - Reference Code.** The code recorded in the MAC, Section II, Column 6.

b. **Column (2) - Remarks.** This column lists information pertinent to the maintenance function being performed as indicated in the MAC, Section II, Column 6.

**Section II. MAINTENANCE ALLOCATION CHART**

(1) Group Number	(2) Component/ Assembly	(3) Maintenance Function	(4) Maintenance Level				(5) Tools and Equipment	(6) Remarks	
			Unit		DS	GS			Depot
			C	O	F	H			D
00	<i>M1022A1 DOLLY SET</i>								
06	<b>ELECTRICAL SYSTEM</b>								
0608	<i>Miscellaneous Items</i>								
	Junction Box Assembly	Replace		0.5				1	
		Repair		1.0				1,2	
	Signal Conditioning Box	Replace		0.5				1	
		Repair		1.0				1,2	

**Section II. MAINTENANCE ALLOCATION CHART (Con't)**

(1)  Group Number	(2)  Component/ Assembly	(3)  Maintenance Function	(4) Maintenance Level					(5)  Tools and Equipment	(6)  Remarks
			Unit		DS	GS	Depot		
			C	O	F	H	D		
0609	<i>Lights</i>								
	Marker Clearance Lights	Replace		0.5				1	
		Repair		0.5				1,2	
	Taillight and Rear	Replace		0.5				1	
	Blackout Lights	Repair		0.5				1,2	
	Identification Light	Replace		0.5				1	
		Repair		0.5				1,2	
0612	<i>Batteries, Storage</i>	Inspect	0.2						
		Test		0.3				2	
		Service		0.5				1,2	
		Replace		0.3				1,2	
	Battery Case	Replace		0.3				1,2	
	Battery Cables	Replace		0.3				1	
0613	<i>Hull or Chassis Wiring Harness</i>								
	Interconnecting Cables	Replace		0.2					
<b>10</b>	<b>FRONT AXLE</b>								
1000	<i>Front Axle Assembly</i>	Service		0.3				2	
		Replace			4.0			1,4	
		Repair		1.0				1,2	
	Front Drawbar	Replace		1.0				1,2	
1004	<i>Steering and Leaning Wheel Mechanism</i>								
	Steering Knuckle Assembly	Replace		3.0				1,2	
<b>11</b>	<b>REAR AXLE</b>								
1100	<i>Rear Axle Assembly</i>	Replace			4.0			1,4	
<b>12</b>	<b>BRAKES</b>								
1202	<i>Service Brakes</i>	Adjust		0.5				1,2	
		Replace		1.0				1,2	
		Repair		0.5				1,2	

**Section II. MAINTENANCE ALLOCATION CHART (Con't)**

(1) Group Number	(2) Component/ Assembly	(3) Maintenance Function	(4) Maintenance Level					(5) Tools and Equipment	(6) Remarks
			Unit		DS	GS	Depot		
			C	O	F	H	D		
1208	<i>Airbrake System</i>	Service	0.1						
	Airbrake Valves	Replace		0.5				1	
	Air Reservoir	Replace		0.5				1	
	Lines and Fittings	Replace		0.5				1	
	Airbrake Chamber	Replace		0.5				1	
<b>13</b>	<b>WHEELS AND TRACKS</b>								
1311	<i>Wheel Assembly</i>	Inspect	0.1						
		Service		0.5				1,2	
		Adjust		0.5				1,2	
		Replace		0.5				1,2,3	
		Repair		0.5				1,2	
	Brakedrum	Replace		0.5				1,2	
		Repair			1.0				A
1313	<i>Tires, Tubes, Tire Chains</i>								
	Tire and Tube	Service	0.2						
		Replace		0.5				1,2	
		Repair		0.5	1.0				B
<b>14</b>	<b>STEERING</b>								
1401	<i>Mechanical Steering Gear Assembly</i>	Service		0.3				2	
	Tie-rod Assembly	Adjust		0.5				1,3	
		Replace		0.5				1,2	
		Repair		0.5				1,2	
	Steering Link	Replace		2.0				1,2	
<b>15</b>	<b>FRAME, TOWING ATTACHMENTS, DRAWBARS, AND ARTICULATION SYSTEMS</b>								
1501	<i>Frame Assembly</i>	Replace	2.0					1,2,3	
	Suspension Link	Replace			4.0			1,4	
	Pivoting Tray	Service		0.2				2	
		Replace		2.0				1,2	
	Telescopic Brace	Replace		0.1					

**Section II. MAINTENANCE ALLOCATION CHART (Con't)**

(1) Group Number	(2) Component/ Assembly	(3) Maintenance Function	(4) Maintenance Level					(5) Tools and Equipment	(6) Remarks
			Unit		DS	GS	Depot		
			C	O	F	H	D		
1503	<i>Pintles and Towing Attachments</i>								
	Rear Drawbar	Replace		0.5				1	
1507	<i>Landing Gear, Leveling Jacks</i>								
	Caster Wheel Assembly	Service	0.1	0.2				2	
		Replace		0.5				1,2	
		Repair		0.5				1	
<b>16</b>	<b>SPRINGS AND SHOCK ABSORBERS</b>								
1604	<i>Shock Absorber Equipment</i>								
	Shock Absorber	Replace		0.5				1	
	Air Bag	Service	0.2						
		Replace		1.0				1,2	
<b>18</b>	<b>BODY, CAB, HOOD, AND HULL</b>								
1808	<i>Stowage Racks, Boxes, Straps, Carrying Cases, Cable Reels, Hose Reels, Etc.</i>								
	Toolbox	Replace		0.3				1,2	
<b>22</b>	<b>BODY, CHASSIS, AND HULL ACCESSORY ITEMS</b>								
22.2	<i>Accessory Items</i>								
	Reflectors	Replace		0.2				1	
2210	<i>Data Plates and Instructions Holders</i>								
	Data Plates	Replace		0.2				1	

**Section II. MAINTENANCE ALLOCATION CHART (Con't)**

(1) Group Number	(2) Component/Assembly	(3) Maintenance Function	(4) Maintenance Level					(5) Tools and Equipment	(6) Remarks
			Unit		DS	GS	Depot		
			C	O	F	H	D		
<b>24</b>	<b>HYDRAULIC AND FLUID SYSTEMS</b>								
2401	<i>Pump and Motor</i>								
	<i>Hydraulic Pump</i>	Replace		1.0				1,2	
2402	<i>Manifold and/or Control Valves</i>								
	<i>Hydraulic Control Valve</i>	Replace Repair		1.0	1.0			1,2 1,4	
2406	<i>Strainers, Filters, Lines, and Fittings, Etc.</i>								
	<i>Hydraulic Lines and Fittings</i>	Replace		0.5				1,2	
2407	<i>Hydraulic Cylinders</i>								
	<i>Hydraulic Lift Cylinder</i>	Service Replace Repair		0.2 0.5	2.0	4.0		2 1,2 1,4	
	<i>Hydraulic Positioning Cylinder</i>	Replace Repair		4.0	2.0			1,2 1,4	
2408	<i>Liquid Tanks of Reservoirs</i>								
	<i>Hydraulic Reservoir</i>	Service Replace	0.1	0.3 0.5				1,2 1,2	
<b>29</b>	<b>AUXILIARY GENERATOR AND ENGINE, AND CONTROLS</b>								
2910	<i>Engine Assembly</i>	Inspect Service Adjust Replace	0.1 0.1	0.3 0.5 1.0				1,2 1 1,2	
2913	<i>Flywheel Assembly</i>	Replace		0.5				1,2,3	
2915	<i>Valves, Camshafts, and Timing System</i>								
	<i>Rocker Arm Cover</i>	Replace		0.3				1,2	

Section II. MAINTENANCE ALLOCATION CHART (Con't)

(1) Group Number	(2) Component/Assembly	(3) Maintenance Function	(4) Maintenance Level					(5) Tools and Equipment	(6) Remarks
			Unit		DS	GS	Depot		
			C	O	F	H	D		
2916	Engine Lubrication System								
	Oil Cooler Lines	Replace		0.3				1	
	Oil Filter	Replace		0.3				1,2	
2932	Engine Fuel Pump								
	Injection Pump	Replace		1.0				1,3	
	Nozzle Holder	Test			0.5				
		Replace		0.3				1,3	
2933	Engine Air Cleaner	Service	0.3						
		Replace		0.3				1,2	
		Repair		0.3				1,2	
2935	Engine Fuel Tank	Replace		0.3				1,2	
		Repair		0.3				1	
2941	Engine Muffler, Exhaust, and Tail Pipes								
	Muffler Assembly	Replace		0.5				1,3	
2952	Engine Cowling Deflectors, Air Ducts, and Shrouds	Replace		0.2				1	
2961	Generator								
	Stator Assembly	Replace		1.0				1,2,3	
2962	Regulator	Replace		0.3				1	
2963	Starter, Solenoids, Circuit Breakers, Wiring, and Switches								
	Engine Starter and Switch	Replace		1.0				1	
2965	Ignition Coil								
	Glow Plug	Replace		0.5				1,3	
33	<b>SPECIAL PURPOSE KITS</b>								
3307	Special Purpose Kits								
	Redundant Power Kit	Repair		0.5				1,2	
	Side Lift Kit	Install			8.0			1,4,5,6	
	Cold Start Kit	Install		0.5				1	
		Repair		0.3				1	

**Section III. TOOL AND TEST EQUIPMENT REQUIREMENTS**

(1) Tool or Test Equipment Reference Code	(2) Maintenance L e v e l	(3) Nomenclature	(4) National/NATO Stock Number	(5) Tool Number
1	O,F,H	Tool Kit, General Mechanic's: Automotive	5180-00-177-7033	W33004
2	O	Shop Equipment, Automotive Maintenance and Repair: Common No. 1, Less Power	4910-00-754-0654	W32593
3	O	Shop Equipment, Automotive Maintenance and Repair: Common No. 2, Less Power	4910-00-754-0650	W32730
4	F,H	Shop Equipment, Automotive Maintenance and Repair: Field Maintenance, Basic, Less Power	4910-00-754-0705	T24660
<b>SPECIAL TOOLS</b>				
5	O,F	Bushing, Pipe (30780) 0502-8-4		
6	O,F	Gage, Pressure, Dial: 0-6000 psi (61349) 151469	6665-01-373-7976	

**Section IV. REMARKS**

(1) Reference Code	(2) Remarks
A	Repair of brakedrum consists of refacing brakedrum braking surface with a brakedrum lathe.
B	Refer to TM 9-2610-200-14 for tire and tube repair.
C	Clean and test nozzle holder at Direct Support Maintenance.
D	Initial installation of side lift kit is to be performed at Direct Support Maintenance (See paragraph 5-9).





## APPENDIX C REPAIR PARTS AND SPECIAL TOOLS LISTS

### Section I. INTRODUCTION

#### C-1. SCOPE.

This RPSTL lists and authorizes spares and repair pans; special tools; special test, measurement, and diagnostic equipment (TMDE); and other special support equipment required for performance of Unit, Direct Support, and General Support Maintenance of the M1022A1 Dolly Set. It authorizes the requisitioning, issue, and disposition of spares, repair parts, and special tools as indicated by the Source, Maintenance, and Recoverability (SMR) codes.

#### C-2. GENERAL.

In addition to Section I, Introduction, this Repair Parts and Special Tools List is divided into the following sections:

a. **Section II, Repair Pans List.** A list of spares and repair parts authorized by this RPSTL for use in the performance of maintenance. The list also includes parts which must be removed for replacement of the authorized pans. Pans lists are composed of functional groups in ascending alphanumeric sequence, with the parts in each group listed in ascending figure and item number sequence. Bulk materials are listed by item name sequence at the end of the section. Repair parts kits are listed separately in their own functional group within Section II. Repair pans for repairable special tools are also listed in this section. Items listed are shown on the associated illustration(s)/figure(s).

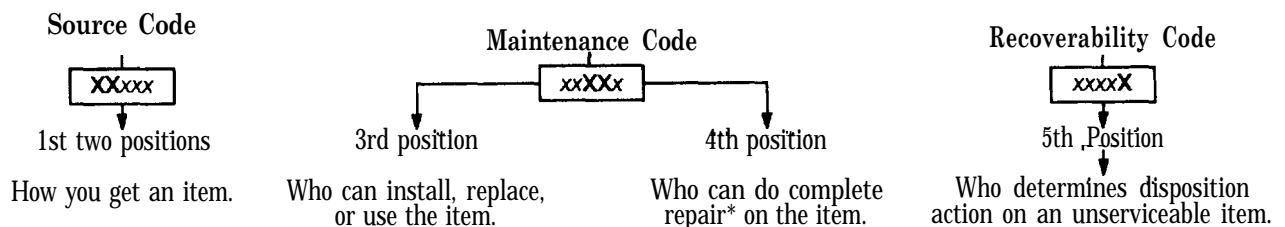
b. **Section III, Special Tools List.** A list of special tools, special TMDE, and other special support equipment authorized by this RPSTL [as indicated by Basis of Issue (BOI) information in the DESCRIPTION AND USABLE ON CODE (UOC) column] for the performance of maintenance.

c. **Section IV, Cross-reference Indexes.** A list, in National Item Identification Number (NIIN) sequence, of all National stock numbered items appearing in the listing, followed by a list in alphanumeric sequence of all part numbers appearing in the listings. National stock numbers and part numbers are cross-referenced to each illustration/figure and item number appearance.

#### C-3. EXPLANATION OF COLUMNS (SECTIONS II AND III).

a. **ITEM NO. - Column (1).** Indicates the number used to identify items called out in the illustration.

b. **SMR CODE - Column (2).** The Source, Maintenance, and Recoverability (SMR) code is a five-position code containing supply/requisitioning information, maintenance category authorization criteria, and disposition instruction, as shown in the following breakout:



\* *Complete Repair:* Maintenance capacity, capability, and authority to perform all corrective maintenance tasks of the "Repair" function in a use/user environment in order to restore serviceability to a failed item.

**C-3. EXPLANATION OF COLUMNS (SECTIONS II AND III) (Con't).**

(1) **Source Code.** The source code tells you how to get an item needed for maintenance, repair, or overhaul of an end item/equipment. Explanations of source codes follow:

<u>Code</u>	<u>Application/Explanation</u>
PA PB PC** PD PE PF PG	Stocked items; use the applicable NSN to request/requisition items with these source codes. They are authorized to the category indicated by the code entered in the third position of the SMR code.  .....
KD KF KB	.....
MO - Made at UM/AVUM Level MF - Made at DS/AVIM Level MH - Made at GS Level ML - Made at Specialized Repair Activity (SRA) MD - Made at Depot	Items with these codes are not to be requested/requisitioned individually. They must be made from bulk materiel which is identified by the part number in the DESCRIPTION AND USABLE ON CODE (UOC) column and listed in the Bulk Materiel group of the repair parts list in this RPSTL. If the item is authorized to you by the third position of the SMR code, but the source code indicates it is made at a higher level, order the item from the higher level of maintenance.  .....
AO - Assembled by UM/AVUM Level AF - Assembled by DS/AVIM Level AH - Assembled by GS Level AL - Assembled by SRA AD - Assembled at Depot	Items with these codes are not to be requested/requisitioned Individually. The parts that make up the assembled item must be requisitioned or fabricated and assembled at the level of maintenance indicted by the source code. If the third position of the SMR code authorizes you to replace the item, but the source code indicates that the item is assembled at a higher level, order the item from the higher level of maintenance.  .....

**NOTE**

Cannibalization or controlled exchange, when authorized, may be used as a source of supply for Items with the following source codes, except for those source coded "XA" or those aircraft support items restricted by requirements of AR 700-42.

<u>Code</u>	<u>Application/Explanation</u>
XA .....	DO NOT requisition an "XA"-coded item. Order its next higher assembly.
XB .....	If an "XB" item is not available from salvage, order it using the CAGE and part number given.

---

**C-3. EXPLANATION OF COLUMNS (SECTIONS II AND III) (Con't).**

---

<u>Code</u>	<u>Application/Explanation</u>
XC . . . . .	installation drawing, diagram, instruction sheet, or field service drawing that is identified by manufacturer's part number.
XD . . . . .	Item is not stocked. Order an "XD"-coded item through normal supply channels using the CAGE and part number given, if no NSN is available.

(2) **Maintenance Code.** Maintenance codes tell you the level(s) of maintenance authorized to use and repair support items. The maintenance codes are entered in the third and fourth positions of the SMR code as follows:

- (a) The maintenance code entered in the third position tells you the lowest maintenance level authorized to remove, replace, and use an item. The maintenance code entered in the third position will indicate authorization to one of the following levels of maintenance.

<u>Code</u>	<u>Application/Explanation</u>
C . . . . .	Operator or Crew Maintenance done within Unit Maintenance or aviation unit maintenance.
O . . . . .	Unit Maintenance or aviation unit maintenance can remove, replace, and use the item.
F . . . . .	Direct Support Maintenance or aviation intermediate maintenance can remove, replace, and use the item.
H . . . . .	General Support Maintenance can remove, replace, and use the item.
L . . . . .	Specialized Repair Activity (SRA) can remove, replace, and use the Item.
D . . . . .	Depot Maintenance can remove, replace, and use the item.

**NOTE**

**Some limited repair may be done on the item at a lower level of maintenance, If authorized by the Maintenance Allocation Chart (MAC) and SMR codes.**

- (b) The maintenance code entered In the fourth position tells whether or not the item is to be repaired and identifies the lowest maintenance level with the capability to do complete repair (i.e., perform all authorized "Repair" functions). me maintenance code entered in the fourth position will indicate authorization to one of the following levels of maintenance.

<u>Code</u>	<u>Application/Explanation</u>
O . . . . .	Unit Maintenance or aviation unit maintenance is the lowest level that can do complete repair of the item.
F . . . . .	Direct Support Maintenance or aviation intermediate maintenance is the lowest level than can do complete repair of the item.
H . . . . .	General Support Maintenance is the lowest level that can do complete repair of the item.

---

**C-3. EXPLANATION OF COLUMNS (SECTIONS II AND III) (Con't).**

---

<i>Code</i>	<u><i>Application/Explanation</i></u>
<i>L</i> . . . . .	Specialized Repair Activity (SRA) is the lowest level that can do complete repair of the item.
<i>D</i> . . . . .	Depot Maintenance is the lowest level that can do complete repair of the item.
<i>Z</i> . . . . .	Nonreparable. No repair is authorized.
<i>B</i> . . . . .	No repair is authorized. (No pans or special tools are authorized for the maintenance of a "B"-coded item.) However, the item may be reconditioned by adjusting, lubricating, etc., at the user level.

(3) **Recoverability Code.** Recoverability codes are assigned to items to indicate the disposition action on unserviceable items. The recoverability code is entered in the fifth position of the SMR code as follows:

<i>Code</i>	<u><i>Application/Explanation</i></u>
<i>Z</i> . . . . .	Nonreparable item. When unserviceable, condemn and dispose of the item at the level of maintenance shown in the third position of the SMR code.
<i>O</i> . . . . .	Reparable item. When uneconomically repairable, condemn and dispose of the item at Unit Maintenance or aviation unit maintenance.
<i>F</i> . . . . .	Reparable item. When uneconomically repairable, condemn and dispose of the item at Direct Support Maintenance or aviation intermediate maintenance.
<i>H</i> . . . . .	Reparable item. When uneconomically repairable, condemn and dispose of the item at General Support Maintenance.
<i>D</i> . . . . .	Reparable item. When beyond lower level repair capability, return to Depot Maintenance. Condemnation and disposal of item is not authorized below Depot Maintenance.
<i>L</i> . . . . .	Reparable item. Condemnation and disposal of item is not authorized below Specialized Repair Activity (SRA).
<i>A</i> . . . . .	Item requires special handling or condemnation procedures because of specific reasons (e.g., precious metal content, high dollar value, critical material, or hazardous material). Refer to appropriate manuals/directives for specific instructions.

c. **NSN - Column (3)**. Lists the National stock number assigned to the item. Use the NSN for requests/requisitions.

d. **CAGEC - Column (4)**. The Commercial and Government Entity (CAGE) Code (C) Is a five-digit alphanumeric code which is used to identify the manufacturer, distributor, or Government agency, etc., that supplies the item.

---

**C-3. EXPLANATION OF COLUMNS (SECTIONS II AND III) (Con't).**


---

**NOTE**

When you use an NSN to requisition an item, the item you receive may have a different part number from the part ordered.

e. **PART NUMBER - Column (5).** Indicates the primary number used by the manufacturer (individual, company, firm, corporation, or Government activity) which controls the design and characteristics of the item by means of its engineering drawings, specifications standards, and inspection requirements to identify an item or range of items.

f. **DESCRIPTION AND USABLE ON CODE (UOC) - Column (6).** This column includes the following information:

- (1) The Federal item name and, when required, a minimum description to identify the item.
- (2) Physical security classification. Not Applicable.
- (3) Items that are included in kits and sets are listed below the name of the kit or set.
- (4) Spare/repair parts that make up an assembled Item are listed immediately following the assembled item line entry.
- (5) Part numbers for bulk materials are referenced in this column in the line item entry for the item to be manufactured/fabricated.
- (6) When the item is not used with all serial numbers of the same model, the effective serial numbers are shown on the last line(s) of the description (before UOC). Not Applicable.
- (7) The Usable On Code, when applicable (see paragraph C-5, Special Information).
- (8) In the Special Tools List section, the Basis of Issue (BOI) appears as the last line(s) in the entry for each special tool, special TMDE, and other special support equipment. When density of equipment supported exceeds density spread indicated in the Basis of Issue, the total authorization is increased proportionately.
- (9) The statement "END OF FIGURE" appears just below the last item description in Column 6 for a given figure in both Section II and Section III.

g. **QTY- Column (7).** The QTY (quantity per figure) column indicates the quantity of the Item used in the breakout shown on the illustration/figure, which is prepared for a functional group, subfunctional group, or an assembly. A "V" appearing in this column in lieu of a quantity indicates that the quantity is variable and the quantity may vary from application to application.

---

**C-4. EXPLANATION OF COLUMNS (SECTION IV).**


---

a. **National Stock Number (NSN) Index.**

- (1) **STOCK NUMBER Column.** This column lists the NSN by National Item Identification Number (NIIN) sequence. The NIIN consists of the last nine digits of the NSN (i.e., 5305-01-<sup>NSN</sup>674-1467). When using this NIIN column to locate an item, ignore the first four digits of the NSN. However, the complete NSN should be used when ordering items by stock number.

---

#### C-4. EXPLANATION OF COLUMNS (SECTION IV) (Con't).

---

(2) **FIG. Column.** This column lists the number of the figure where the item is Identified/located. The figures are in numerical order in Section ii and Section ill.

(3) **ITEM Column.** The item number identifies the item associated with the figure listed in the adjacent FIG. column. This item is also identified by the NSN listed on the same line.

b. **Part Number index.** Pan numbers in this index are listed by part number in ascending alphanumeric sequence (i.e., vertical arrangement of letter and number combination which places the first letter or digit of each group in order A through Z, followed by the numbers 0 through 9 and each following letter or digit in like order).

(1) **CAGEC Column.** The Commercial and Government Entity (CAGE) Code (C) is a five-digit alphanumeric code used to identify the manufacturer, distributor, or Government agency, etc., that supplies the item.

(2) **PART NUMBER Column.** Indicates the primary number used by the manufacturer (individual, firm, corporation, or Government activity) which controls the design and characteristics of the item by means of its engineering drawings, specifications, standards, and inspection requirements to identify an item or range of items.

(3) **STOCK NUMBER Column.** This column lists the NSN for the associated part number and manufacturer Identified in the PART NUMBER and CAGEC columns to the left.

(4) **FIG. Column.** This column lists the number of the figure where the item is identified/located in Section II or Section III.

(5) **ITEM Column.** The item number assigned to the item as it appears in the figure referenced In the FIG. column.

---

#### C-5. SPECIAL INFORMATION.

---

a. **Usable On Code.** The Usable On Code appears in the lower left corner of the DESCRIPTION column heading. Not Applicable.

b. **Fabrication Instructions.** Bulk materials required to manufacture items are listed in the Bulk Materiel functional group of this RPSTL. Part numbers for bulk materials are also referenced in the Description column of the line item entry for the item to be manufactured/fabricated. Detailed fabrication instructions for items source coded to be manufactured or fabricated are found in Chapters 4 and 5.

c. **Assembly Instructions.** Detailed assembly instructions for items source coded to be assembled from component spare/repair parts are found in Chapters 4 and 5. Items that make up the assembly are listed immediately following the assembly item entry or reference is made to an applicable figure.

d. **Kits.** Line item entries for repair parts kits appear in Group 9401 in Section II.

e. **Index Numbers.** Items which have the word BULK in the FIG. column will have an index number shown in the item column. This index number is a cross-reference between the National Stock Number Index, the Pan Number Index, and the bulk materiel list in Section II.

---

**C-6. HOW TO LOCATE REPAIR PARTS.**

---

When National Stock Number or Part Number Is Known:

(1) **First.** Using the National Stock Number Index or Part Number Index, find the pertinent NSN or part number. The NSN Index is in National Item Identification Number (NIIN) sequence [see paragraph C4.a.(1)]. The part numbers in the Part Number Index are listed in ascending alphanumeric sequence (see paragraph C-4.b). Both indexes cross-reference you to the illustration/figure and item number of the item you are looking for.

(2) **Second.** Turn to the figure and item number, verify that the item is the one you're looking for, then locate the item number in the repair parts list for the figure.

---

**C-7. ABBREVIATIONS.**

---

For standard abbreviations see MIL-STD-12D, *Military Standard Abbreviations for Use on Drawings, Specifications, Standards, and in Technical Documents.*

<u>Abbreviations</u>	<u>Explanation</u>
NIIN .....	National item Identification Number (consists of the last 9 digits of the NSN)
RPSTL .....	Repair Parts and Special Tools Lists

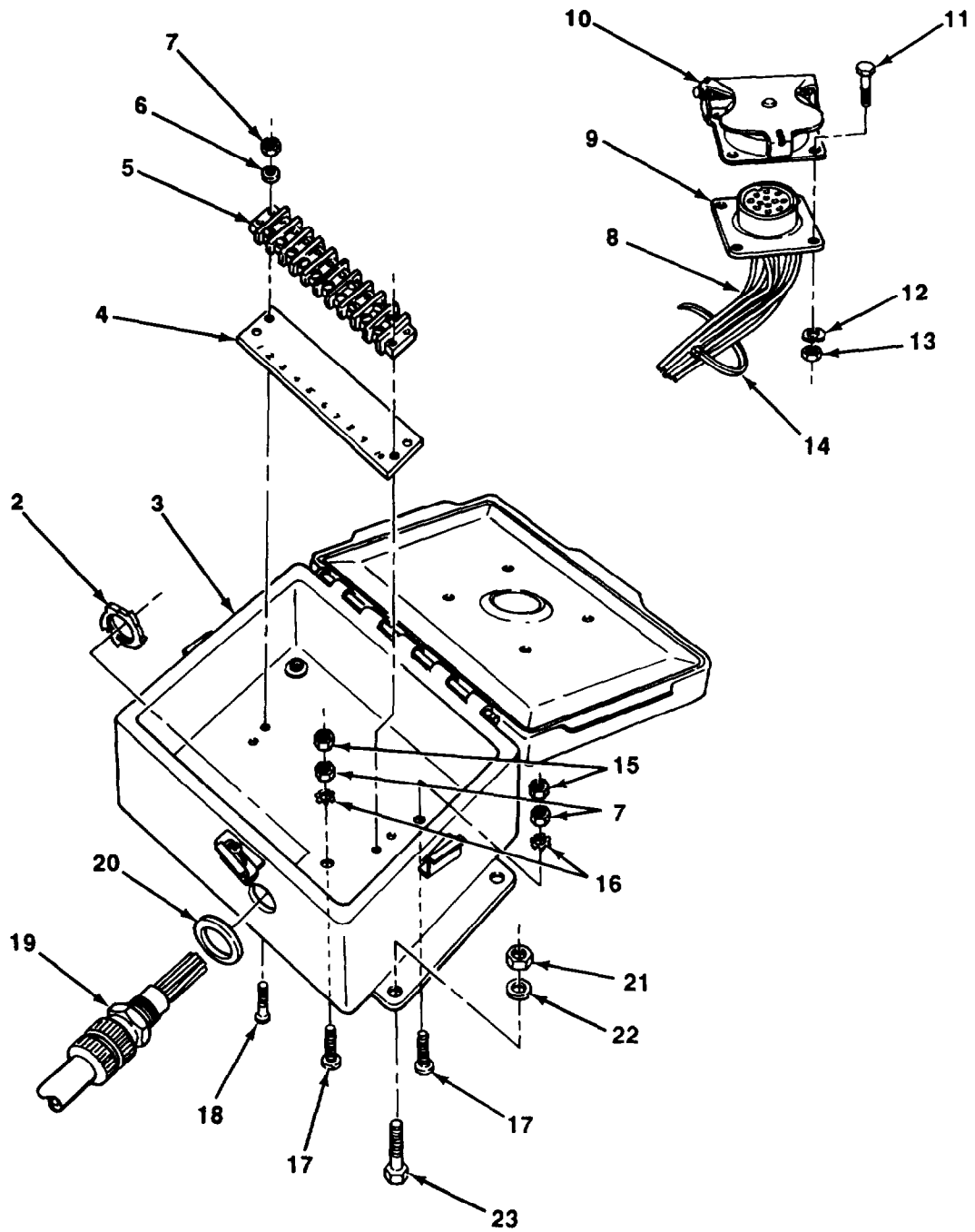
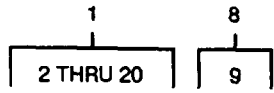


FIGURE 1. FORWARD JUNCTION BOX.



(1) ITEM NO	(2) SMR CODE	(3) NSN	(4) CAGEC	(5) PART NUMBER	(6) DESCRIPTION AND USABLE ON CODES (UOC)	(7) QTY
<b>GROUP 06 ELECTRICAL SYSTEM</b>						
<b>GROUP 0608 MISCELLANEOUS ITEMS</b>						
<b>FIG. 1 FORWARD JUNCTION BOX</b>						
1	PFOOO	6110013938898	21439	8D00101-1	DISTRIBUTION BOX . . . . .	1
2	PFOZZ	5310014186243	21439	9C00015-16	.NUT,SELF-LOCKING,RO 3/4. . . . .	1
3	PFOZZ	5975014186041	21439	8D00186-1	.JUNCTION BOX . . . . .	1
4	PFOZZ	5940013461336	13556	007-00098-3	.MARKER STRIP,TERMIN . . . . .	1
5	XAOZZ		13556	004-00293-1	.TERMINAL BLOCK . . . . .	1
6	PAOZZ	5310007225998	96906	MS15795-805	.WASHER,FLAT #6 . . . . .	2
7	PAOZZ	5310009826813	96906	MS21044C06	.NUT,SELF-LOCKING,HE #6-32. . . . .	4
8	PAOZZ	6150013936171	21439	8D00066-10	.CABLE ASSEMBLY,POWE . . . . .	1
9	PAOZZ	5935008463884	96906	MS75021-2	.CONNECTOR,RECEPTACL. . . . .	1
10	PAOZZ	5975013217295	16528	7731428	.COVER,JUNCTION BOX . . . . .	1
11	PAOZZ	5305000680501	96906	MS90725-5	.SCREW,CAP,HEXAGON H 1/4-20 X 5/8. . . . .	4
12	PAOZZ	5310005825965	96906	MS35338-44	.WASHER,LOCK 1/4 . . . . .	4
13	PAOZZ	5310009971888	96906	MS35649-2252	.NUT,PLAIN,HEXAGON 1/4-20. . . . .	4
14	PAOZZ	5975000742072	96906	MS3367-1-9	.STRAP,TIEDOWN,ELECT. . . . .	15
15	PAOZZ	5310009349761	97424	N226P13-1	.NUT,PLAIN,HEXAGON #6-32 . . . . .	2
16	PAOZZ	5310002090788	96906	MS35335-30	.WASHER,LOCK #6 . . . . .	2
17	PAOZZ	5305000546659	96906	MS51957-35	.SCREW,MACHINE #6-32 X 1 1/4. . . . .	2
18	PAOZZ	5305000546656	96906	MS51957-32	.SCREW,MACHINE #6-32 X 3/4 . . . . .	2
19	PAOZZ		21439	9C00015-9	.TERMINAL,QUICK DIS. . . . .	1
20	PFOZZ	5330013934855	21439	9C00015-18	.SEAL RING,METAL. . . . .	1
21	PAOZZ	5310008892589	96906	MS21044C4	NUT,SELF-LOCKING,HE 1/4-28. . . . .	4
22	PAOZZ	5310013048733	96906	MS15795-852	WASHER,FLAT 1/4 . . . . .	4
23	PAOZZ	5306001562339	88044	AN4C7A	BOLT,MACHINE 1/4-28 X 7/16 . . . . .	4

END OF FIGURE

1  
2 THRU 29

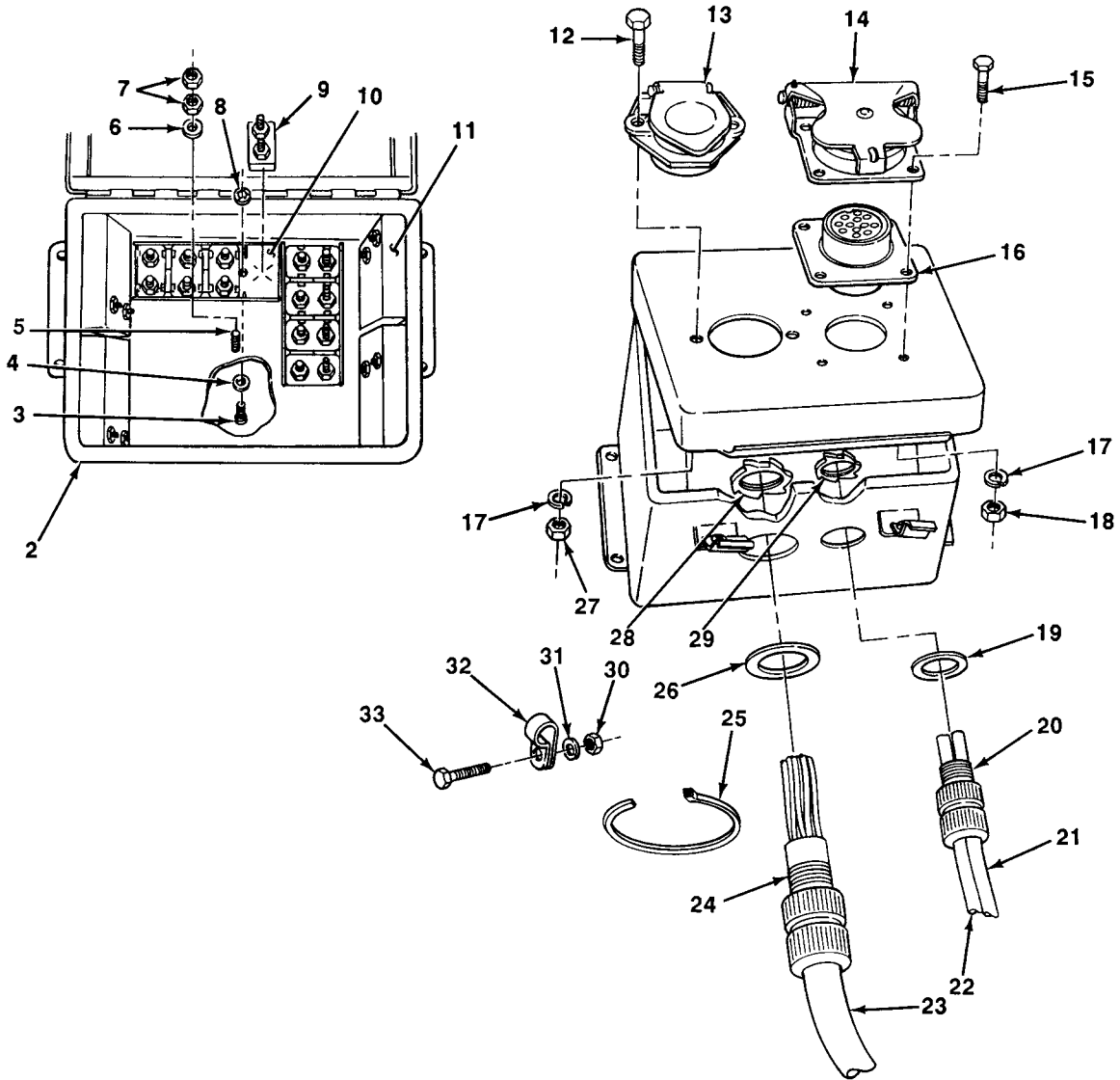


Figure 2. Signal Conditioning Box.

(1) ITEM NO	(2) SMR CODE	(3) NSN	(4) CAGEC	(5) PART NUMBER	(6) DESCRIPTION AND USABLE ON CODES (UOC)	(7) QTY
<b>GROUP 0608 MISCELLANEOUS ITEMS</b>						
<b>FIG. 2 SIGNAL CONDITIONING BOX</b>						
1	PAOOO		21439	8D00112-1	SIGNAL CONDITIONING . . . . .	1
2	PFOZZ	5340013932867	4J564	12360744	.COVER,ACCESS . . . . .	1
3	PAOZZ	5305008893002	96906	MS35206-242	.SCREW,MACHINE . . . . .	4
4	PAOZZ	5310007653197	96906	MS27183-41	.WASHER,FLAT . . . . .	4
5	PAOZZ	5305009846214	96906	MS35206-267	.SCREW,MACHINE . . . . .	3
6	PAOZZ	5310008098546	96906	MS27183-8	.WASHER,FLAT . . . . .	3
7	PAOZZ	5310009349764	96906	MS35649-205	.NUT,PLAIN,HEXAGON . . . . .	6
8	PAOZZ	5310001448453	96906	MS90724-7	.NUT,SHEET SPRING . . . . .	4
9	PAOZZ	5925009001903	98343	1512-1-15	.CIRCUIT BREAKER . . . . .	8
10	PAOZZ	5340014299351	19207	12368919	.BRACKET,MOUNTING . . . . .	2
11	PAOZZ	6110014657511	4J564	DT318	.CONTROL,VOLTAGE REG . . . . .	4
12	PAOZZ	5305000680502	96906	MS90725-6	.SCREW,CAP,HEXAGON H. . . . .	2
13	PAOZZ	5935011410877	98343	782	.CONNECTOR,RECEPTACL . . . . .	1
14	PAOZZ	5975013217295	16528	7731428	.COVER,JUNCTION BOX . . . . .	1
15	PAOZZ	5305000680500	96906	MS90725-3	.SCREW,CAP,HEXAGON H. . . . .	4
16	PAOZZ	5935008463883	96906	MS75021-1	.CONNECTOR,RECEPTACL . . . . .	1
17	PAOZZ	5310005825965	96906	MS35338-44	.WASHER,LOCK . . . . .	6
18	PAOZZ	5310009971888	96906	MS35649-2252	.NUT,PLAIN,HEXAGON . . . . .	4
19	PFOZZ	5330013935637	21439	9C00015-17	.SEAL RING,METAL . . . . .	1
20	PFOZZ		21439	9C00015-6	.CORD CONNECTOR . . . . .	1
21	PFOZZ	6150013935108	21439	8D00066-5	.WIRING HARNESS . . . . .	1
22	PFOZZ	6150013935107	21439	8D00066-6	.WIRING HARNESS . . . . .	1
23	PFOZZ	6150013935114	21439	8D00066-4	.CABLE ASSEMBLY,POWER . . . . .	1
24	PAOZZ	5975012070229	81992	SHC-1037	.BOX CONNECTOR,ELECT. . . . .	1
25	PAOZZ	5975000742072	96906	MS3367-1-9	.STRAP,TIEDOWN,ELECT. . . . .	10
26	PFOZZ	5330013934855	21439	9C00015-18	.SEAL RING,METAL . . . . .	1
27	PAOZZ	5310007320558	96906	MS51967-8	.NUT,PLAIN,HEXAGON . . . . .	2
28	PFOZZ	5310014186243	21439	9C00015-16	.NUT,SELF-LOCKING,RO 3/4 . . . . .	1
29	PFOZZ	5975001521075	03743	BL50	.LOCKNUT,ELECTRICAL 1/2 . . . . .	1
30	PAOZZ	5310002089255	96906	MS21044C3	NUT,SELF-LOCKING,HE #10-32 . . . . .	1
31	PAOZZ	5310006151556	28527	2616950G001	WASHER,FLAT #10 . . . . .	1
32	PAOZZ	5340002008559	96906	MS21919WDG7	CLAMP,LOOP . . . . .	1
33	PAOZZ	5305000593661	96906	MS51958-65	SCREW,MACHINE #10-32 X 3/4 . . . . .	1

END OF FIGURE

1	18
2 THRU 29	19

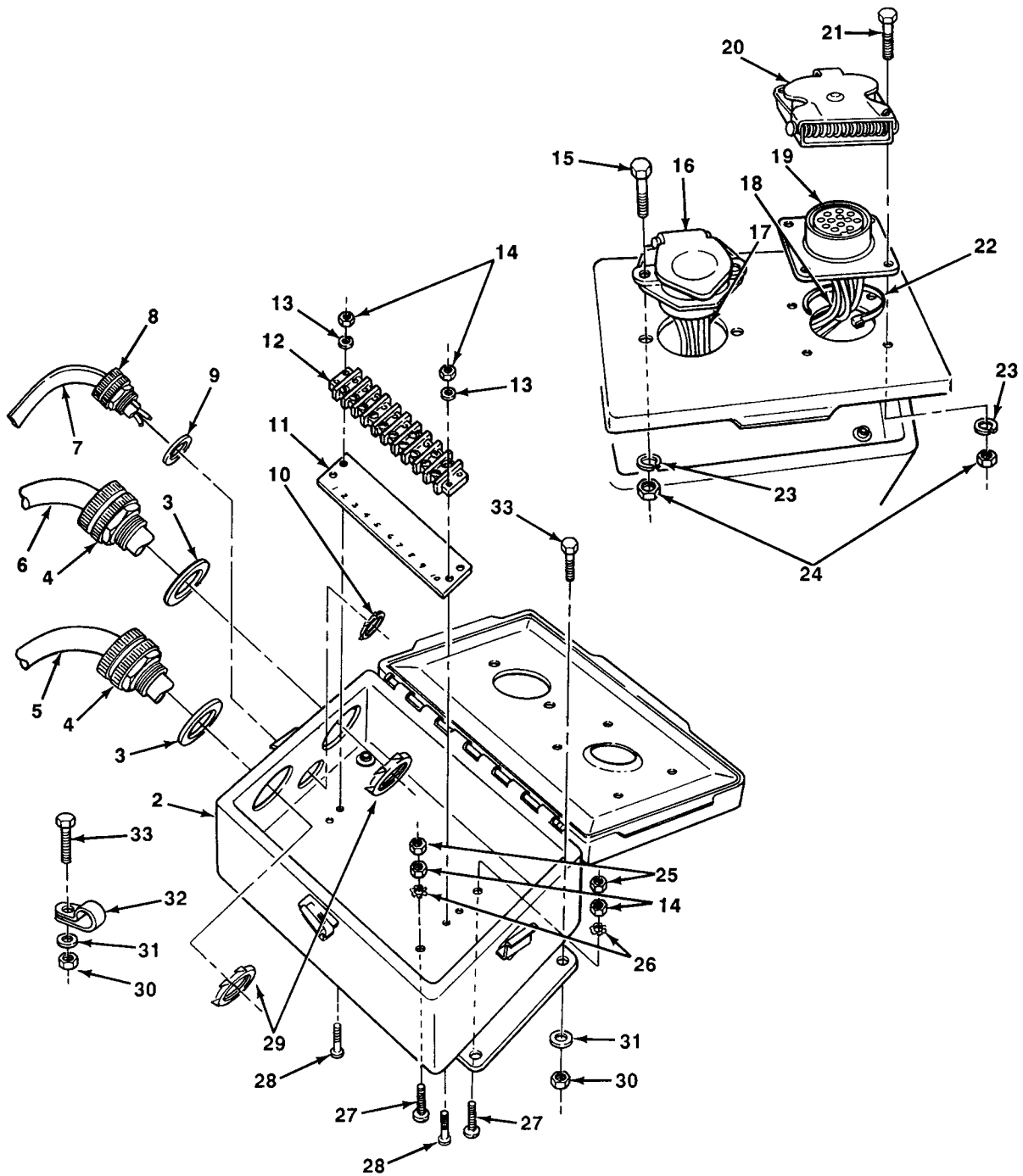


Figure 3. Rear Junction Box.

(1) ITEM NO	(2) SMR CODE	(3) NSN	(4) CAGEC	(5) PART NUMBER	(6) DESCRIPTION AND USABLE ON CODES (UOC)	(7) QTY
<b>GROUP 0608 MISCELLANEOUS ITEMS</b>						
<b>FIG. 3 REAR JUNCTION BOX</b>						
1	PFOOO	6110013938897	21439	8D00129-1	DISTRIBUTION BOX . . . . .	1
2	PFOZZ	4940013935874	21439	8D00135-1	.ENCLOSURE,ELECTROMA . . . . .	1
3	PFOZZ	5330013934855	21439	9C00015-18	.SEAL RING,METAL . . . . .	2
4	PAOZZ		21439	9C00015-9	.TERMINAL,QUICK DIS . . . . .	2
5	PAOZZ	6150013935110	21439	8D00066-8	.CABLE ASSEMBLY,POWER . . . . .	1
6	PAOZZ	6150013935109	21439	8D00066-7	.CABLE ASSEMBLY,POWER . . . . .	1
7	PAOZZ	6150013936173	21439	8D00066-9	.WIRING HARNESS . . . . .	1
8	PAOZZ	5935013937232	21439	9C00015-2	.CONNECTOR,PLUG,ELEC. . . . .	1
9	PFOZZ	5330013935637	21439	9C00015-17	.SEAL RING,METAL . . . . .	1
10	PFOZZ	5975014185108	21439	9C00015-15	.LOCKNUT,ELECTRICAL 1/2 . . . . .	1
11	PFOZZ	5940013461336	13556	007-00098-3	.MARKER STRIP,TERMIN . . . . .	1
12	XAOZZ		13556	004-00293-1	.TERMINAL BLOCK . . . . .	1
13	PAOZZ	5310007225998	96906	MS15795-805	.WASHER,FLAT #6 . . . . .	2
14	PAOZZ	5310009826813	96906	MS21044C06	.NUT,SELF-LOCKING,HE #6-32 . . . . .	4
15	PAOZZ	5305000680502	96906	MS90725-6	.SCREW,CAP,HEXAGON H 1/4-20 X 3/4 . . . . .	2
16	PAOZZ	5935013942106	21439	8D00129-6	.CONNECTOR,RECEPTACL . . . . .	1
17	PAOZZ	6150013936208	21439	8D00066-12	.CABLE ASSEMBLY,POWE . . . . .	1
18	PAOZZ	6150013936172	21439	8D00066-11	.CABLE ASSEMBLY,POWE . . . . .	1
19	PAOZZ	5935008463883	96906	MS75021-1	..CONNECTOR,RECEPTACL . . . . .	1
20	PAOZZ	5975013217295	16528	7731428	.COVER,JUNCTION BOX . . . . .	1
21	PAOZZ	5305000680501	96906	MS90725-5	.SCREW,CAP,HEXAGON H 1/4-20 X 5/8 . . . . .	4
22	PAOZZ	5975000742072	96906	MS3367-1-9	.STRAP,TIEDOWN,ELECT. . . . .	5
23	PAOZZ	5310005825965	96906	MS35338-44	.WASHER,LOCK 1/4 . . . . .	6
24	PAOZZ	5310009971888	96906	MS35649-2252	.NUT,PLAIN,HEXAGON 1/4-20 . . . . .	6
25	PAOZZ	5310009349761	96906	MS35649-264	.NUT,PLAIN,HEXAGON #6-32 . . . . .	2
26	PAOZZ	5310002090788	96906	MS35335-30	.WASHER,LOCK #6 . . . . .	2
27	PAOZZ	5305004110682	96906	MS51957-124	.SCREW,MACHINE #6-32 X 1 1/8 . . . . .	2
28	PAOZZ	5305000546656	96906	MS51957-32	.SCREW,MACHINE #6-32 X 3/4 . . . . .	2
29	PFOZZ	5975006427261	03743	BL75	.LOCKNUT,ELECTRICAL 3/4 . . . . .	2
30	PAOZZ	5310008892589	96906	MS21044C4	NUT,SELF-LOCKING,HE 1/4-28 . . . . .	5
31	PAOZZ	5310013048733	96906	MS15795-852	WASHER,FLAT 1/4 . . . . .	5
32	PAOZZ	5340012135535	96906	MS9352-14	CLAMP,LOOP . . . . .	1
33	PAOZZ	5306001562338	88044	AN4C6A	BOLT,MACHINE 1/4-28 X 1/2 . . . . .	5

END OF FIGURE

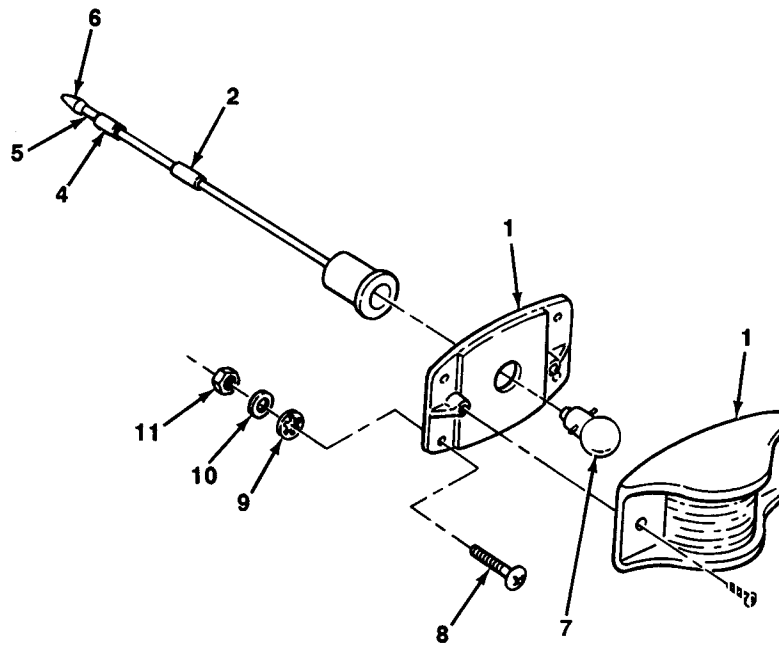
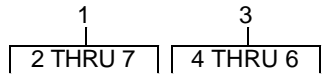


Figure 4. Marker Clearance Light Assembly.

(1) ITEM NO	(2) SMR CODE	(3) NSN	(4) CAGEC	(5) PART NUMBER	(6) DESCRIPTION AND USABLE ON CODES (UOC)	(7) QTY
<b>GROUP 0609 LIGHTS</b>						
<b>FIG. 4 MARKER CLEARANCE LIGHT ASSEMBLY</b>						
1	PAOZZ	6220013934024	21439	8D00105-3	LIGHT ASSEMBLY,CLEAR. ....	1
2	PFOZZ	7690014180407	21439	8D00105-13	.MARKER,IDENTIFICATION .....	1
3	PAOZZ	5935001677775	96906	MS27144-1	.CONNECTOR,PLUG,ELEC. ....	1
4	PAOZZ	5935008338561	19207	8338561	..SHELL,ELECTRICAL CO. ....	1
5	PAOZZ	5970008338562	19207	8338562	..INSULATOR,BUSHING .....	1
6	PAOZZ	5940003996676	19207	8338564	..TERMINAL SET,QUICK .....	1
7	PAOZZ	6240001558717	80204	67	.LAMP,INCANDESCENT .....	1
8	PAOZZ	5305000593661	96906	MS51958-65	SCREW,MACHINE #10-32 X 3/4 .....	4
9	PAOZZ	5310005435933	96906	MS35333-73	WASHER,LOCK #10 .....	4
10	PAOZZ	5310006151556	28527	2616950G001	WASHER,FLAT #10 .....	4
11	PAOZZ	5310002089255	96906	MS21044C3	NUT,SELF-LOCKING,HE #10-32 .....	4

END OF FIGURE

1	2	7
2 THRU 29	3 THRU 12	8 THRU 10
19	22	
20 THRU 25	23 THRU 25	

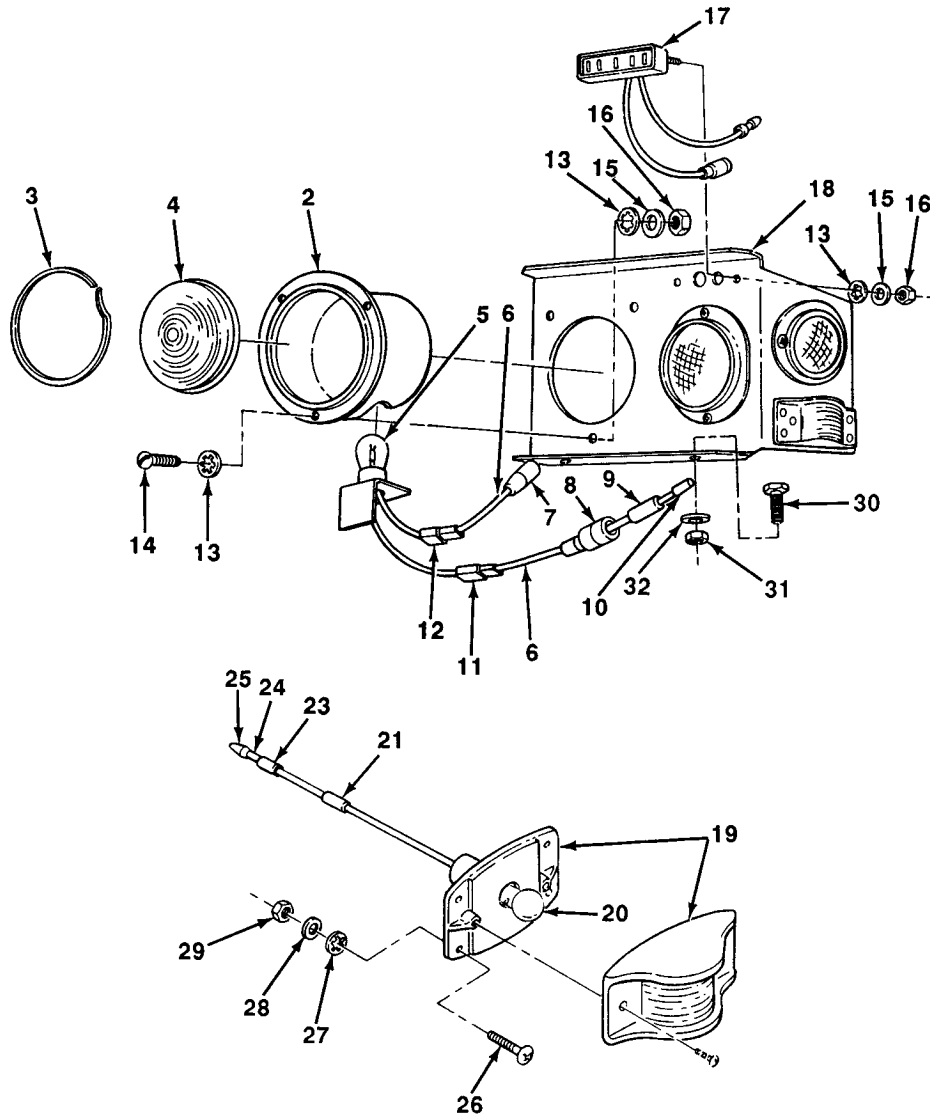


Figure 5. Taillight Assembly.



(1) ITEM NO	(2) SMR CODE	(3) NSN	(4) CAGEC	(5) PART NUMBER	(6) DESCRIPTION AND USABLE ON CODES (UOC)	(7) QTY
<b>GROUP 0609 LIGHTS</b>						
<b>FIG. 5 TAILLIGHT ASSEMBLY</b>						
1	AOOOO		21439	8D00138-1	TAILLIGHT ASSY,RH . . . . .	1
1	AOOOO		21439	8D00138-2	TAILLIGHT ASSY,LH . . . . .	1
2	PAOOO	6220013932332	21439	8D00105-1	.TAILLIGHT,VEHICULAR . . . . .	1
2	PAOOO	6220013932335	21439	8D00105-5	.STOP LIGHT-TAILLIGHT . . . . .	1
3	PAOZZ		OKZG3	99595-3	..RING,SNAP . . . . .	1
4	PAOZZ	6210014177034	OKZG3	90012	..LENS,LIGHT. . . . .	1
5	PAOZZ	6240008891799	08806	1157	..LAMP,INCANDESCENT. . . . .	1
6	PAOZZ		OKZG3	68150	..WIRE ASSEMBLY . . . . .	1
7	PAOZZ	5935001152307	96906	MS27144-2	..CONNECTOR,PLUG,ELEC . . . . .	2
8	PAOZZ	5975006605962	19207	8724494	...CABLE NIPPLE,ELECTR . . . . .	1
9	PAOZZ	5970008338562	19207	8338562	...INSULATOR,BUSHING . . . . .	1
10	PAOZZ	5940003996676	19207	8338564	...TERMINAL SET,QUICK. . . . .	1
11	PFOZZ	7690014180407	21439	8D00105-13	..MARKER,IDENTIFICATI. . . . .	1
12	PFOZZ	9905014232596	21439	8D00105-14	..BAND,MARKER R.H. . . . .	1
12	PFOZZ	9905014232590	21439	8D00105-15	..BAND,MARKER L.H. . . . .	1
13	PAOZZ	5310005432739	96906	MS35333-72	.WASHER,LOCK #8 . . . . .	8
14	PAOZZ	5305000546671	96906	MS51957-46	.SCREW,MACHINE #8-32 X 5/16 . . . . .	3
15	PAOZZ	5310008805978	96906	MS15795-807	.WASHER,FLAT 3/16. . . . .	5
16	PAOZZ	5310009826814	96906	MS21044C08	.NUT,SELF-LOCKING,HE #8-32. . . . .	5
17	PAOZZ	6220010885915	19207	12258212	.TAILLIGHT ASSY,BLACK . . . . .	1
18	PFOZZ	6220013934019	21439	8D00139-1	.HOUSING,LIGHT R.H. . . . .	1
18	PFOZZ	6220013932333	21439	8D00139-2	.HOUSING,LIGHT L.H. . . . .	1
19	PAOZZ	6220013932331	21439	8D00105-2	.LIGHT ASSEMBLY,CLEA . . . . .	1
20	PAOZZ	6240001558717	80204	67	..LAMP,INCANDESCENT. . . . .	1
21	PFOZZ	7690014180407	21439	8D00105-13	..MARKER,IDENTIFICATION . . . . .	1
22	PAOZZ	5935001677775	96906	MS27144-1	..CONNECTOR,PLUG,ELEC . . . . .	1
23	PAOZZ	5935008338561	19207	8338561	...SHELL,ELECTRICAL CO . . . . .	1
24	PAOZZ	5970008338562	19207	8338562	...INSULATOR,BUSHING . . . . .	1
25	PAOZZ	5940003996676	19207	8338564	...TERMINAL SET,QUICK. . . . .	1
26	PAOZZ	5305000593660	96906	MS51958-64	.SCREW,MACHINE #10-32 X 5/8. . . . .	4
27	PAOZZ	5310005435933	96906	MS35333-73	.WASHER,LOCK #10 . . . . .	4
28	PAOZZ	5310006151556	28527	2616950G001	.WASHER,FLAT #10 . . . . .	4
29	PAOZZ	5310002089255	96906	MS21044C3	.NUT,SELF-LOCKING,HE #10-32 . . . . .	4
30	PAOZZ	5306001562338	88044	AN4C6A	BOLT,MACHINE 1/4-28 X 1/2 . . . . .	2
31	PAOZZ	5310008892589	96906	MS21044C4	NUT,SELF-LOCKING,HE 1/4-28. . . . .	2
32	PAOZZ	5310013048733	96906	MS15795-852	WASHER,FLAT 1/4 . . . . .	2

END OF FIGURE

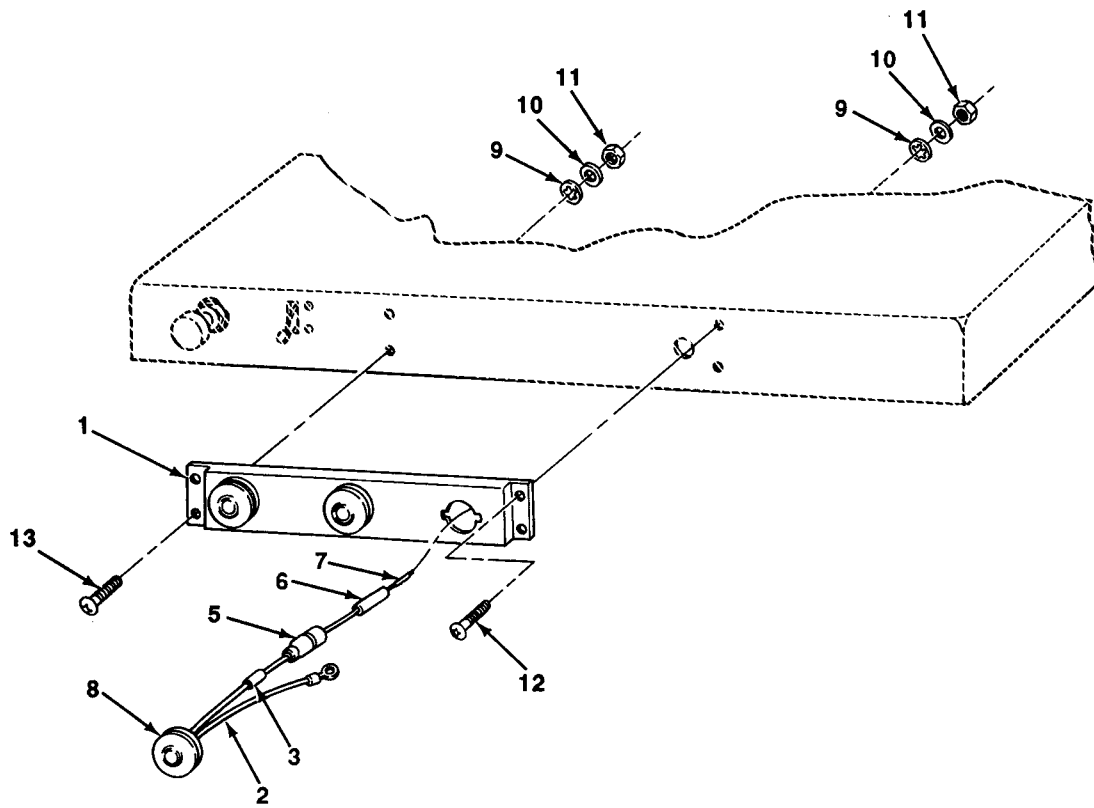
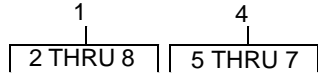


Figure 6. Identification Light Assembly.

(1) ITEM NO	(2) SMR CODE	(3) NSN	(4) CAGEC	(5) PART NUMBER	(6) DESCRIPTION AND USABLE ON CODES (UOC)	(7) QTY
<b>GROUP 0609 LIGHTS</b>						
<b>FIG. 6 IDENTIFICATION LIGHT ASSEMBLY</b>						
1	PAOOO	6220014177414	21439	8D00105-4	LIGHT ASSEMBLY,INDI. ....	1
2	PAOZZ	5995010960733	13548	93906	.LEAD ASSEMBLY,ELECT. ....	1
3	PFOZZ	7690014180407	21439	8D00105-13	.MARKER,IDENTIFICATI. ....	1
4	PAOZZ	5935001152307	96906	MS27144-2	.CONNECTOR,PLUG,ELEC. ....	1
5	PAOZZ	5975006605962	19207	8724494	..CABLE NIPPLE,ELECTR. ....	1
6	PAOZZ	5970008338562	19207	8338562	..INSULATOR,BUSHING. ....	1
7	PAOZZ	5940003996676	19207	8338564	..TERMINAL SET,QUICK. ....	1
8	PAOZZ	6220010853391	13548	30200R	.LAMP UNIT,VEHICULAR. ....	3
9	PAOZZ	5310006163555	96906	MS35333-71	WASHER,LOCK #6. ....	4
10	PAOZZ	5310007225998	96906	MS15795-805	WASHER,FLAT #6. ....	4
11	PAOZZ	5310009826813	96906	MS21044C06	NUT,SELF-LOCKING,HE #6-32. ....	4
12	PAOZZ	5305000546655	96906	MS51957-31	SCREW,MACHINE #6-32 X 3/16. ....	1
13	PAOZZ	5305000546654	89016	F36237-20	SCREW,MACHINE #6-32 X 7/16. ....	3

END OF FIGURE

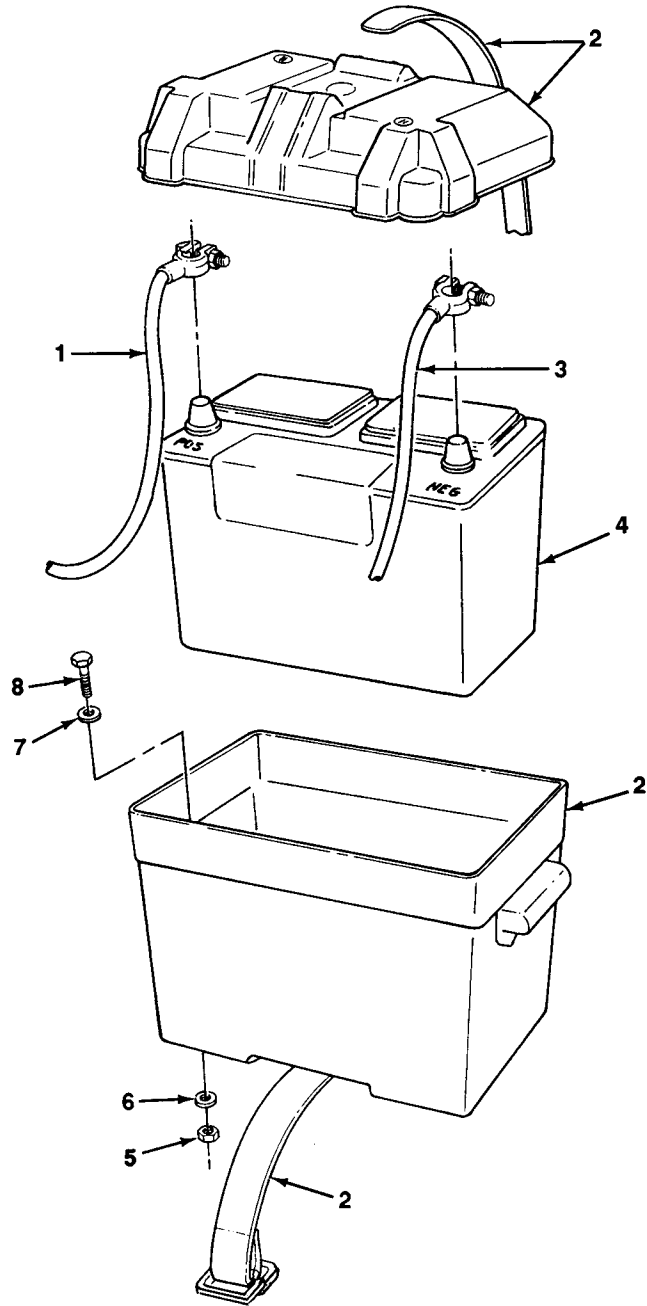


Figure 7. Battery and Case.

(1) ITEM NO	(2) SMR CODE	(3) NSN	(4) CAGEC	(5) PART NUMBER	(6) DESCRIPTION AND USABLE ON CODES (UOC) GROUP 0612 BATTERIES, STORAGE FIG. 7 BATTERY AND CASE	(7) QTY
1	PAOZZ	6140014178062	21439	8D00123-31R	LEAD,STORAGE BATTER FRONT TRAY .....	1
1	PAOZZ	6140014068993	21439	8D00123-48R	LEAD,STORAGE BATTER REAR TRAY.....	1
2	PAOZZ	5120013932582	21439	8D00044-1	CARRIER,STORAGE BATTERY .....	1
3	PAOZZ	6150014062906	21439	8D00123-38B	CABLE ASSEMBLY,SPEC FRONT TRAY.....	1
3	PAOZZ	6140014665416	21439	8D00123-42B	CABLE ASSEMBLY,SPEC REAR TRAY .....	1
4	PAOFF	6140013935106	21439	8D00373-1	BATTERY,WET.....	1
5	PAOZZ	5310000881251	81349	M45913/1-4CG5C	NUT,SELF-LOCKING,HE 1/4-20.....	4
6	PAOZZ	5310001411795	88044	AN960-416	WASHER,FLAT 1/4 .....	4
7	PAOZZ	5310002858124	96906	MS27183-50	WASHER,FLAT 1/4 .....	4
8	PAOZZ	5305002253843	96906	MS90728-8	SCREW,CAP,HEXAGON H 1/4-20 X 1 .....	4

END OF FIGURE

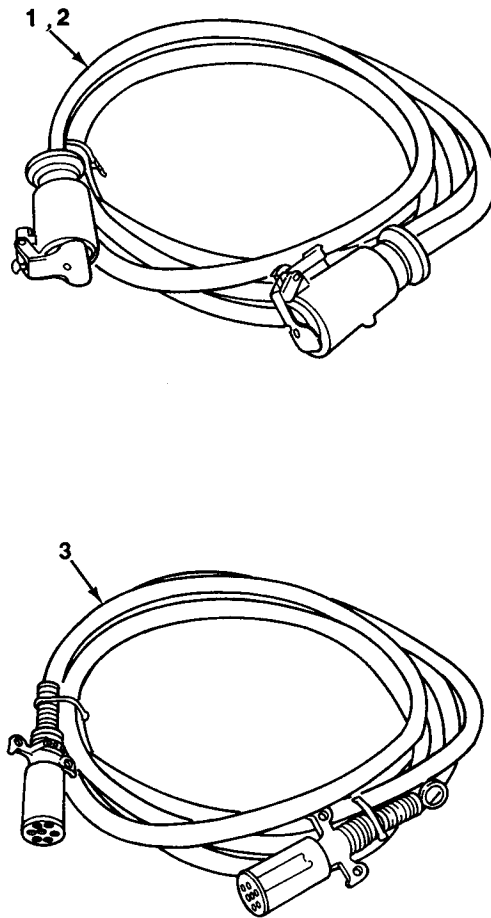


Figure 8. Interconnecting Cables.

(1) ITEM NO	(2) SMR CODE	(3) NSN	(4) CAGEC	(5) PART NUMBER	(6) DESCRIPTION AND USABLE ON CODES (UOC)	(7) QTY
<b>GROUP 0613 HULL OR CHASSIS WIRING HARNESS</b>						
<b>FIG. 8 INTERCONNECTING CABLES</b>						
1	PAOZZ	6150013935112	21439	8D00066-1	CABLE ASSEMBLY,POWER .....	1
2	PAOZZ	6150013935118	21439	8D00066-3	CABLE ASSEMBLY,POWER .....	1
3	PAOZZ	6150013935113	21439	8D00066-2	CABLE ASSEMBLY,POWER .....	1

END OF FIGURE

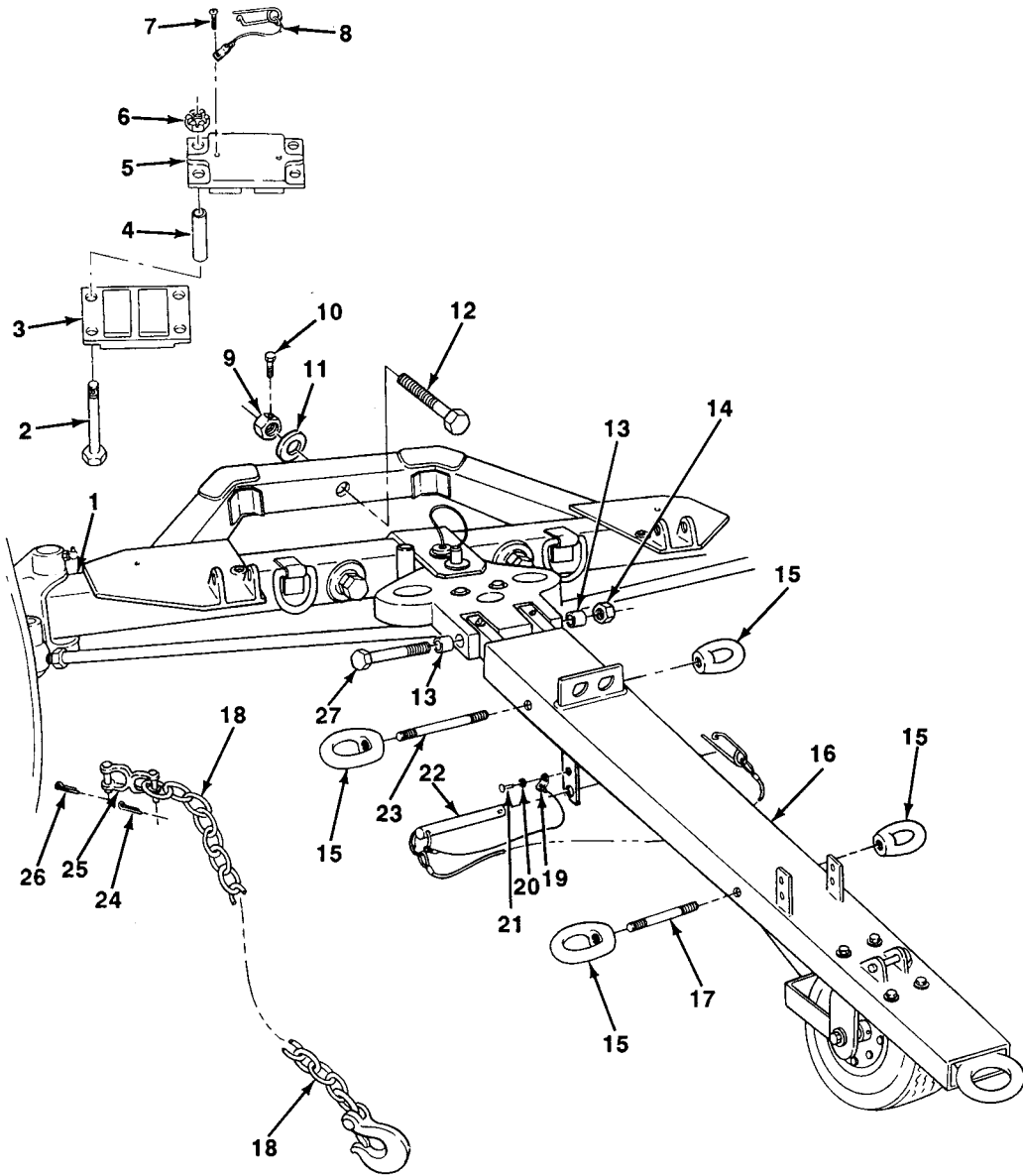


Figure 9. Front Axle.



(1) ITEM NO	(2) SMR CODE	(3) NSN	(4) CAGEC	(5) PART NUMBER	(6) DESCRIPTION AND USABLE ON CODES (UOC)	(7) QTY
<b>GROUP 10 FRONT AXLE</b>						
<b>GROUP 1000 FRONT AXLE ASSEMBLY</b>						
<b>FIG. 9 FRONT AXLE</b>						
1	PFFFF	2530013935169	21439	8D00093-1	AXLE,VEHICULAR,NOND . . . . .	1
2	PAOZZ	5306014225966	21439	8D00236-1	BOLT,SHOULDER . . . . .	8
3	PFOZZ	5340014314073	21439	8D00232-2	BRACKET,ANGLE . . . . .	2
4	PFOZZ	4730014061923	21439	8D00237-1	SLEEVE,COMPRESSION . . . . .	8
5	PFOZZ	5340014193838	21439	8D00232-1	BRACKET,ANGLE . . . . .	2
6	PAOZZ	5310008506881	96906	MS35692-57	NUT,PLAIN,SLOTTED,H . . . . .	8
7	PAOZZ	5305008550960	80205	MS24629-36	SCREW,TAPPING . . . . .	4
8	PAOZZ	4010014313239	21439	8D00316-1	WIRE ROPE ASSEMBLY . . . . .	8
9	PFOZZ	5310013937081	21439	8D00151-2	NUT,PLAIN,HEXAGON 2-4.5 . . . . .	1
10	PAOZZ		21439	16282-219	SCREW,CAP,SOCKET 1/4-20 X 3/4 . . . . .	1
11	PFOZZ	5310014298520	21439	8D00298-1	WASHER,FLAT . . . . .	1
12	PFOZZ	5306013933741	21439	8D00151-1	BOLT,MACHINE 2-4.5 X 10 7/8 . . . . .	1
13	PFFZZ	4730014291321	52793	48139	BUSHING,BOSS . . . . .	2
14	PAOZZ	5310014295029	52793	934050-29	NUT,SELF-LOCKING,HE 1 3/8-12 . . . . .	1
15	PAOZZ	5310013936777	76257	710-0107	NUT,EYE . . . . .	4
16	PFOZZ	2540013937544	21439	8D00091-1	TOWBAR,MOTOR VEHICLE . . . . .	1
17	PFOZZ	5307013933742	21439	8D00082-19	STUD,PLAIN . . . . .	1
18	PAOZZ	4010014060511	21439	8D00070-1	CHAIN,WELDED . . . . .	2
19	PFOZZ	3990014188755	96652	79-07	WIRE,PIN RETAINER . . . . .	1
20	PAOZZ	5310000453299	96906	MS35338-42	WASHER,LOCK #8 . . . . .	1
21	PAOZZ	5305000581082	96906	MS51861-34	SCREW,TAPPING #8 X 1/4 . . . . .	1
22	PFOZZ	5315014297277	21439	8D00341-1	PIN,QUICK RELEASE . . . . .	1
23	PFOZZ	5307013935642	21439	8D00082-18	STUD,PLAIN . . . . .	1
24	PAOZZ	5315008423044	96906	MS24665-283	PIN,COTTER . . . . .	2
25	PFOZZ	3040013935275	76257	S-247-3/8	CONNECTING LINK,RIGHT . . . . .	2
26	PAOZZ	5315013591451	96906	MS24665-285	PIN,COTTER . . . . .	2
27	PFOZZ	5305013950884	21439	8D00195-60	BOLT 1 3/8-12 X 12 1/2 . . . . .	1

END OF FIGURE

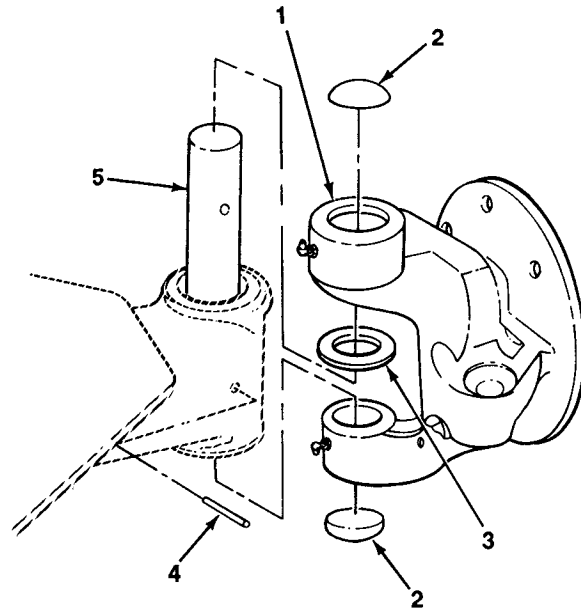
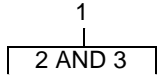


Figure 10. Steering Knuckle Assembly.

(1) ITEM NO	(2) SMR CODE	(3) NSN	(4) CAGEC	(5) PART NUMBER	(6) DESCRIPTION AND USABLE ON CODES (UOC)	(7) QTY
<b>GROUP 1004 STEERING AND LEANING WHEEL MECHANISM</b>						
<b>FIG. 10 STEERING KNUCKLE ASSEMBLY</b>						
1	PBOZZ	2530013932672	21439	8D00195-12	SPINDLE,WHEEL,DRIVING. ....	1
1	PBOZZ	2530013932675	21439	8D00195-10	SPINDLE,WHEEL,DRIVING. ....	1
2	PFOZZ	5340013932878	21439	8D00195-16	.PLUG,PROTECTIVE,DUS. ....	2
3	PFOZZ	5365013930840	21439	8D00195-18	.SPACER,PLATE ....	1
4	PFOZZ	5315013930837	21439	8D00195-26	PIN,SPRING. ....	1
5	PFOZZ	2530013935270	21439	8D00195-25	KINGPIN,WHEEL SPINDLE. ....	1

END OF FIGURE

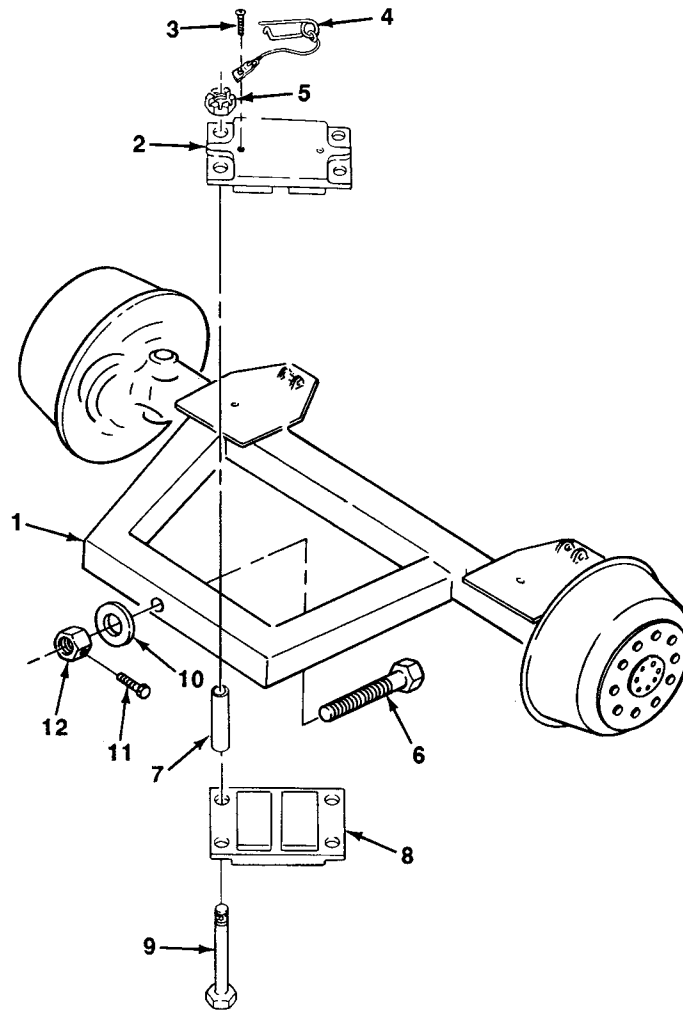


Figure 11. Rear Axle.

(1) ITEM NO	(2) SMR CODE	(3) NSN	(4) CAGEC	(5) PART NUMBER	(6) DESCRIPTION AND USABLE ON CODES (UOC)	(7) QTY
<b>GROUP 11 REAR AXLE</b>						
<b>GROUP 1100 REAR AXLE ASSEMBLY</b>						
<b>FIG. 11 REAR AXLE</b>						
1	PFFFF	2530013935875	21439	8D00130-1	AXLE ASSEMBLY,VEHICLE. ....	1
2	PFOZZ	5340014193838	21439	8D00232-1	BRACKET,ANGLE .....	2
3	PAOZZ	5305008550960	80205	MS24629-36	SCREW,TAPPING .....	4
4	PAOZZ	4010014313239	21439	8D00316-1	WIRE ROPE ASSEMBLY .....	8
5	PAOZZ		21439	8D00313-1	NUT,SLOTTED.....	8
6	PFOZZ	5306013933741	21439	8D00151-1	BOLT,MACHINE 2-4.5 X 10 7/8.....	1
7	PFOZZ	4730014061923	21439	8D00237-1	SLEEVE,COMPRESSION .....	8
8	PFOZZ	5340014314073	21439	8D00232-2	BRACKET,ANGLE .....	2
9	PAOZZ	5306014225966	21439	8D00236-1	BOLT,SHOULDER .....	8
10	PFOZZ	5310014298520	21439	8D00298-1	WASHER,FLAT.....	1
11	PAOZZ		21439	16282-219	SCREW,CAP,SOCKET 1/4-20 X 3/4.....	1
12	PFOZZ	5310013937081	21439	8D00151-2	NUT,PLAIN,HEXAGON 2-4.5 .....	1

END OF FIGURE

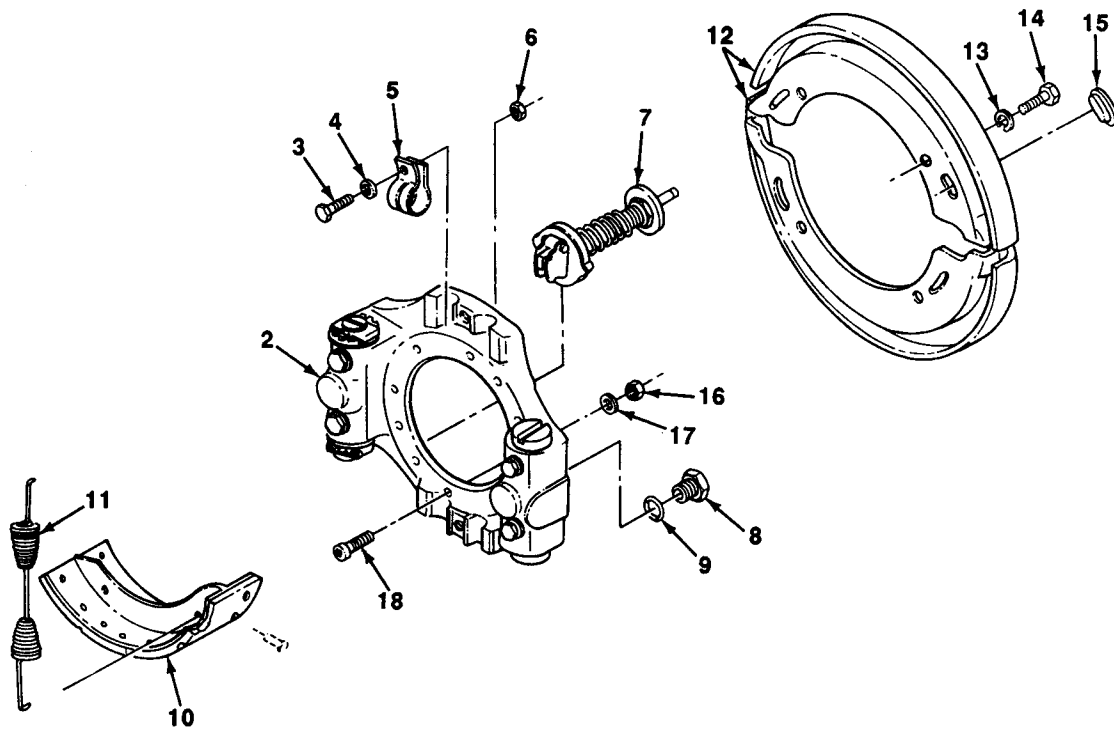
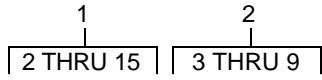


Figure 12. Service Brakes.

(1) ITEM NO	(2) SMR CODE	(3) NSN	(4) CAGEC	(5) PART NUMBER	(6) DESCRIPTION AND USABLE ON CODES (UOC)	(7) QTY
<b>GROUP 12 BRAKES</b>						
<b>GROUP 1202 SERVICE BRAKES</b>						
<b>FIG. 12 SERVICE BRAKES</b>						
1	AOOOO		21439	8D00197-10	BRAKE ASSEMBLY,LEFT FRONT . . . . .	1
1	AOOOO		21439	8D00197-34	BRAKE ASSY,RIGHT FRONT. . . . .	1
1	AOOOO		21439	8D00197-35	BRAKE ASSY,RIGHT REAR. . . . .	1
1	AOOOO		21439	8D00197-38	BRAKE ASSY,LEFT REAR . . . . .	1
2	PAOZZ	2530013935879	21439	8D00197-15	.SPIDER,BRAKE . . . . .	1
3	PFOZZ	5306013935641	21439	8D00197-21	..BOLT,MACHINE . . . . .	2
4	PFOZZ	5310013936316	21439	8D00197-20	..WASHER,LOCK . . . . .	2
5	PFOZZ	5340013936315	21439	8D00197-19	..CLIP,SPRING TENSION. . . . .	2
6	PFOZZ	5340013936784	21439	8D00197-16	..CLIP,RETAINING . . . . .	2
7	PFOZZ	4030013930836	21439	8D00197-37	..WEDGE,DRUM CLAMP,WI . . . . .	1
8	PAOZZ	5310013935643	21439	8D00197-39	..NUT,SLEEVE . . . . .	1
9	PAOZZ	5331013934866	21439	8D00197-40	..O-RING. . . . .	1
10	PAOZZ	2530013935881	21439	8D00197-30	.BRAKE SHOE SET . . . . .	2
11	PAOZZ	5360013930839	21439	8D00197-33	.SPRING,HELICAL,EXTE. . . . .	2
12	PFOZZ	2530013935876	21439	8D00197-13	.PLATE,BACKING,BRAKE . . . . .	2
13	PFOZZ	5310013936312	21439	8D00197-31	.WASHER,LOCK . . . . .	4
14	PFOZZ	5305013935645	21439	8D00197-32	.SCREW,CAP,HEXAGON H. . . . .	4
15	PFOZZ	5340013936309	21439	8D00197-14	.PLUG,PROTECTIVE,DUS. . . . .	2
16	PFOZZ	5310013935646	21439	8D00195-29	NUT,PLAIN,HEXAGON 5/8-18 . . . . .	8
17	PAOZZ	5310008206653	52793	CW7435-57C	WASHER,LOCK 5/8 . . . . .	8
18	PAOZZ		52793	05-047543	SCREW,CAP,HEXAGON 5/8-18 X 2 . . . . .	8

END OF FIGURE

1	28
2	29

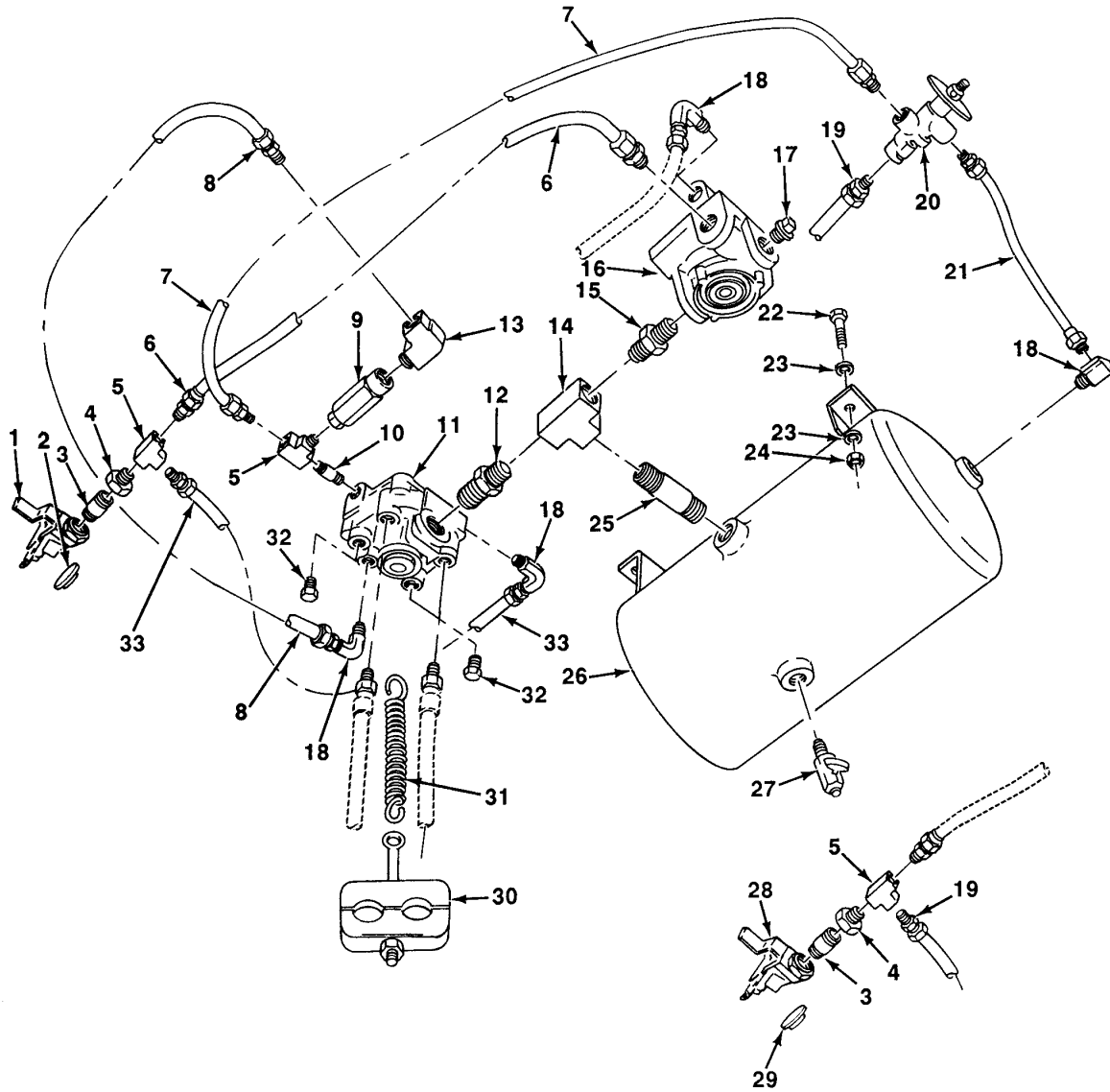


Figure 13. Airbrake Valves, Lines, and Fittings, Front.



(1) ITEM NO	(2) SMR CODE	(3) NSN	(4) CAGEC	(5) PART NUMBER	(6) DESCRIPTION AND USABLE ON CODES (UOC)	(7) QTY
<b>GROUP 1208 AIRBRAKE SYSTEM</b>						
<b>FIG. 13 AIRBRAKE VALVES, LINES, AND FITTINGS, FRONT</b>						
1	PAOZZ	4730005950083	58536	A52484-1	COUPLING HALF,QUICK. ....	1
2	PCOZZ	5330001721919	98343	1509	.PACKING,PREFORMED. ....	1
3	PAOZZ	4730002874852	93061	216P8-6	REDUCER,PIPE. ....	2
4	PAOZZ	4730005111677	93061	207ACBH-6	COUPLING,PIPE ....	2
5	PAOZZ	4730004697797	93061	2225P-6	TEE,PIPE ....	3
6	PFOZZ	4720014227846	21439	8D00064-22	HOSE ASSEMBLY,NONME ....	1
7	PAOZZ		21439	8D00064-21	TUBE ASSEMBLY,METAL ....	1
8	PFOZZ	4720014662736	21439	8D00064-23	TUBE ASSEMBLY ....	1
9	PAOZZ	4820013934549	21439	8D00121-11	VALVE,PNEUMATIC TAN. ....	1
10	PAOZZ	4730002499714	30780	3/8X3/8-FF-B	NIPPLE,PIPE ....	1
11	PAOZZ	2530013934548	21439	8D00121-10	VALVE,BRAKE PNEUMAT ....	1
12	PAOZZ	4730000688656	30780	3-4FFB	NIPPLE,PIPE ....	1
13	PAOZZ	4730012899536	93061	2200P8-8	ELBOW,PIPE ....	1
14	PFOZZ	4730014224160	88763	101A-E	TEE,PIPE ....	1
15	PFOZZ	4730014225721	88763	123A-ED	REDUCER,PIPE. ....	1
16	PFOZZ	2530013937535	21439	8D00121-5	VALVE,RELAY,AIR PRE. ....	1
17	PFOZZ	4730000113176	30780	1-2SHPB	PLUG,PIPE. ....	2
18	PAOZZ	4730002784822	93061	2202P-6-6	ELBOW,PIPE ....	4
19	PAOZZ		21439	8D00064-4	TUBE ASSEMBLY,METAL ....	1
20	PAOZZ	4820013934553	21439	8D00121-1	VALVE,PNEUMATIC TAN. ....	1
21	PFOZZ	4710013937540	21439	8D00064-3	TUBING ASSEMBLY,NON ....	1
22	PAOZZ	5305002693211	96906	MS90725-60	SCREW,CAP,HEXAGON H 3/8-16 X 1 ....	4
23	PAOZZ	5310001670821	88044	AN960-616	WASHER,FLAT 3/8 ....	8
24	PAOZZ	5310000874652	96906	MS51922-17A	NUT,SELF-LOCKING,HE 3/8-16. ....	4
25	PFOZZ	4730014224155	88763	113RB-E3	NIPPLE,PIPE ....	1
26	PAOZZ	2530013935877	21439	8D00097-1	TANK,PRESSURE ....	1
27	PFOZZ	4820013934555	21439	8D00121-6	COCK,DRAIN ....	1
28	PAOZZ	4730005950083	58536	A52484-1	COUPLING HALF,QUICK. ....	1
29	PCOZZ	5330001721919	98343	1509	.PACKING,PREFORMED. ....	1
30	PAOZZ	4730013856972	98343	11541	CLAMP,HOSE. ....	1
31	PAOZZ	5360013885783	56988	C243	SPRING,HELICAL,EXTE ....	1
32	PAOZZ	4730004275121	01276	2082-6B	PLUG,PIPE. ....	4
33	PAOZZ		21439	8D00064-24	TUBE ASSEMBLY,METAL ....	1

END OF FIGURE

11	13
12	14

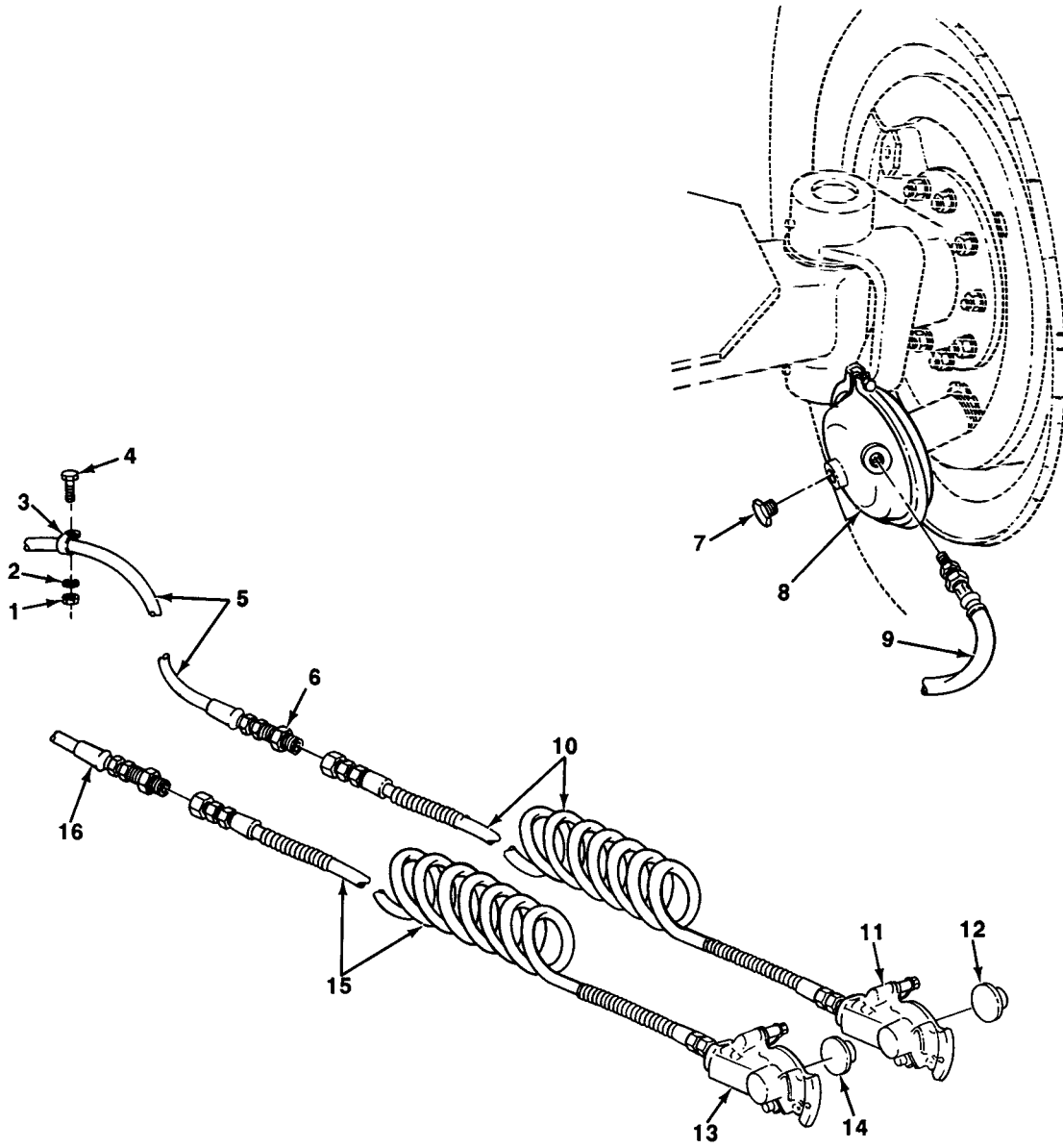


Figure 14. Airbrake Chamber and Lines, Front.

(1) ITEM NO	(2) SMR CODE	(3) NSN	(4) CAGEC	(5) PART NUMBER	(6) DESCRIPTION AND USABLE ON CODES (UOC)	(7) QTY
<b>GROUP 1208 AIRBRAKE SYSTEM</b>						
<b>FIG. 14 AIRBRAKE CHAMBER AND LINES, FRONT</b>						
1	PAOZZ	5310000874652	96906	MS51922-17A	NUT,SELF-LOCKING,HE 3/8-16 .....	1
2	PAOZZ	5310001670821	88044	AN960-616	WASHER,FLAT 3/8 .....	1
3	PFOZZ	5340013952166	98441	CL-13	CLAMP,LOOP .....	1
4	PAOZZ	5305001159526	80204	B1821BH038C075D	SCREW,CAP,HEXAGON H 3/8-16 X 3/4 .....	1
5	PCOZZ	4720013932161	98441	F273017B-6-8-6-6B	HOSE ASSEMBLY,NONME .....	1
6	PFOZZ	4730004070571	30327	129-B-08X24	COUPLING,PIPE .....	2
7	PAOZZ	4730004275121	01276	2082-6B	PLUG,PIPE .....	1
8	PAOZZ	2530013937163	21439	8D00197-11	CHAMBER,AIR BRAKE .....	2
9	PAOZZ	4720014289692	21439	8D00063-3	HOSE ASSEMBLY,NONME RIGHT.....	1
9	PAOZZ		98441	2730101-6-8-6B-64	HOSE ASSEMBLY,NONME LEFT .....	1
10	PAOZZ	4720013935252	93061	741590-RED	TUBING ASSEMBLY,NON .....	1
11	PAOZZ	4730005950083	58536	A52484-1	COUPLING HALF,QUICK .....	1
12	PCOZZ	5330001721919	98343	1509	.PACKING,PREFORMED .....	1
13	PAOZZ	4730005950083	58536	A52484-1	COUPLING HALF,QUICK .....	1
14	PCOZZ	5330001721919	98343	1509	.PACKING,PREFORMED .....	1
15	PAOZZ	4720013935250	61424	741590-BLUE	TUBING ASSEMBLY,NON .....	1
16	PCOZZ	4720014061924	21439	8D00063-7	HOSE ASSEMBLY,NONME .....	1

END OF FIGURE

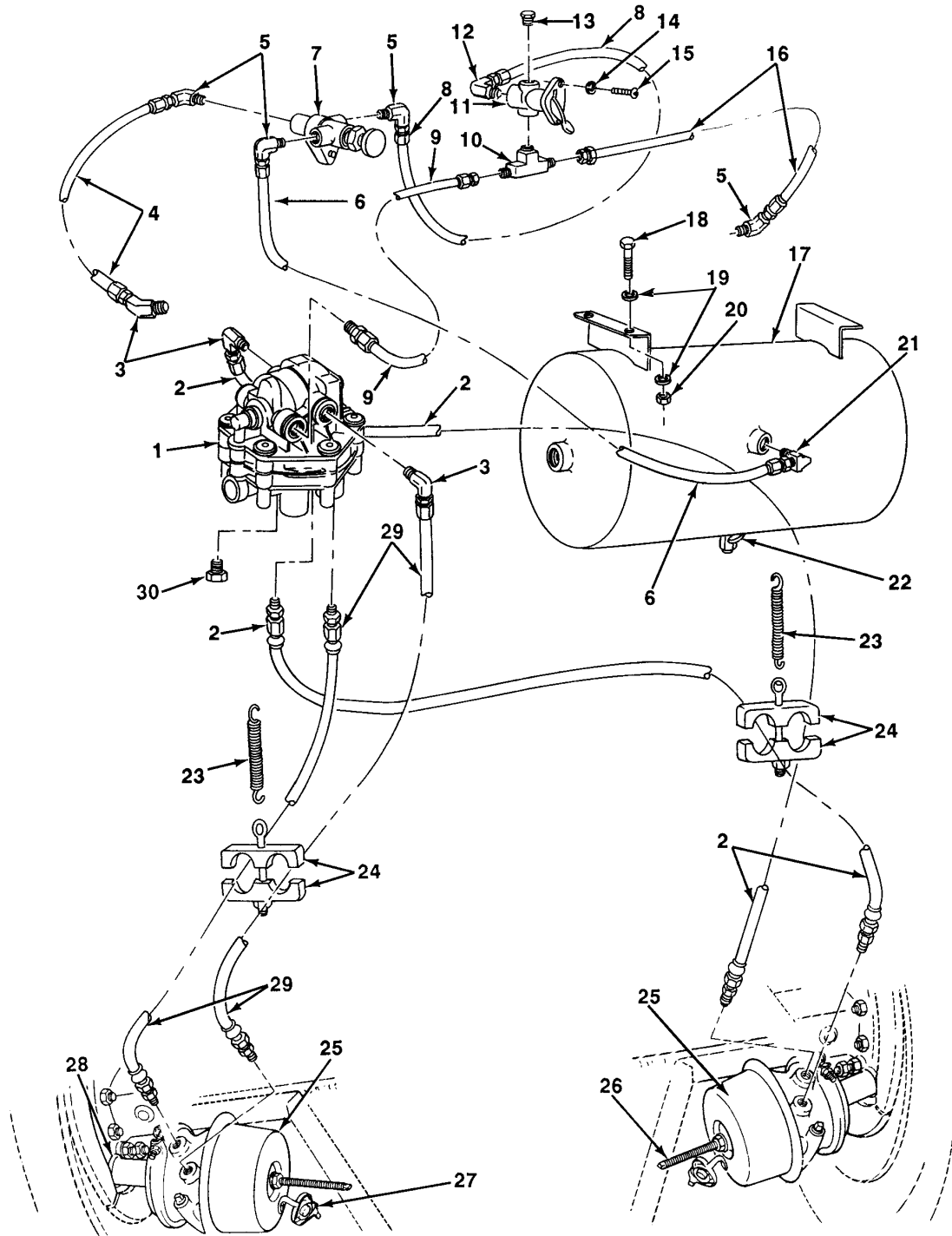


Figure 15. Airbrake Chambers, Lines, and Fittings, Rear.

(1) ITEM NO	(2) SMR CODE	(3) NSN	(4) CAGEC	(5) PART NUMBER	(6) DESCRIPTION AND USABLE ON CODES (UOC)	(7) QTY
<b>GROUP 1208 AIRBRAKE SYSTEM</b>						
<b>FIG. 15 AIRBRAKE CHAMBERS, LINES, AND FITTINGS, REAR</b>						
1	PAOZZ	4820013935255	21439	8D00121-12	VALVE,PNEUMATIC TAN. ....	1
2	PCOZZ	4720014289691	21439	8D00063-1	HOSE ASSEMBLY,NONME .....	2
3	PAOZZ		30780	2214-6-6	ELBOW,PIPE .....	3
4	PFOZZ	4720013934578	21439	8D00064-14	HOSE ASSEMBLY,NONME .....	1
5	PAOZZ		30780	1202P4-4	ELBOW,PIPE .....	4
6	PAOZZ		21439	8D00064-8	TUBE ASSEMBLY,METAL .....	1
7	PAOZZ	4820013934553	21439	8D00121-1	VALVE,PNEUMATIC TAN. ....	1
8	PFOZZ	4720013934579	21439	8D00064-15	HOSE ASSEMBLY,NONME .....	1
9	PFOZZ	4710014061922	21439	8D00064-20	TUBE ASSEMBLY,METAL .....	1
10	PAOZZ	4730005950251	93061	2224P-2	TEE,PIPE .....	1
11	PAOZZ	4820013934551	21439	8D00121-9	VALVE,PNEUMATIC TAN. ....	1
12	PAOZZ	4730008100059	89346	120401	ELBOW,PIPE .....	1
13	PAOZZ	4730002873281	54641	336	PLUG,PIPE. ....	1
14	PAOZZ	5310000453296	96906	MS35338-43	WASHER,LOCK #10 .....	2
15	PAOZZ	5305000509231	96906	MS51957-65	SCREW,MACHINE #10-24 X 3/4. ....	2
16	PFOZZ	4710014061925	21439	8D00064-19	TUBE ASSEMBLY,METAL .....	1
17	PAOZZ	2530013935256	21439	8D00097-2	TANK,PRESSURE .....	1
18	PAOZZ	5305002693211	96906	MS90725-60	SCREW,CAP,HEXAGON H 3/8-16 X 1 .....	4
19	PAOZZ	5310001670821	88044	AN960-616	WASHER,FLAT 3/8 .....	8
20	PAOZZ	5310000874652	96906	MS51922-17	NUT,SELF-LOCKING,HE 3/8 X 16 .....	4
21	PAOZZ	4730002784822	93061	2202P-6-6	ELBOW,PIPE .....	2
22	PFOZZ	4820013934555	21439	8D00121-6	COCK,DRAIN .....	1
23	PAOZZ	5360013885783	56988	C243	SPRING,HELICAL,EXTE .....	2
24	PAOZZ	4730013856972	98343	11541	CLAMP,HOSE. ....	2
25	PAOZZ	2530013935279	21439	8D00197-36	CHAMBER,AIR BRAKE .....	2
26	PAOZZ	2530010953561	50153	T-110M11	STUD ASSEMBLY,RELEA .....	2
27	PAOZZ		50153	T-211M11	COVER,DUST .....	2
28	PAOZZ	5310014314074	21439	8D00197-12	NUT,PLAIN,HEXAGON. ....	2
29	PAOZZ	4720014289692	21439	8D00063-3	HOSE ASSEMBLY,NONME .....	2
30	PAOZZ	4730004275121	01276	2082-6B	PLUG,PIPE. ....	3

END OF FIGURE

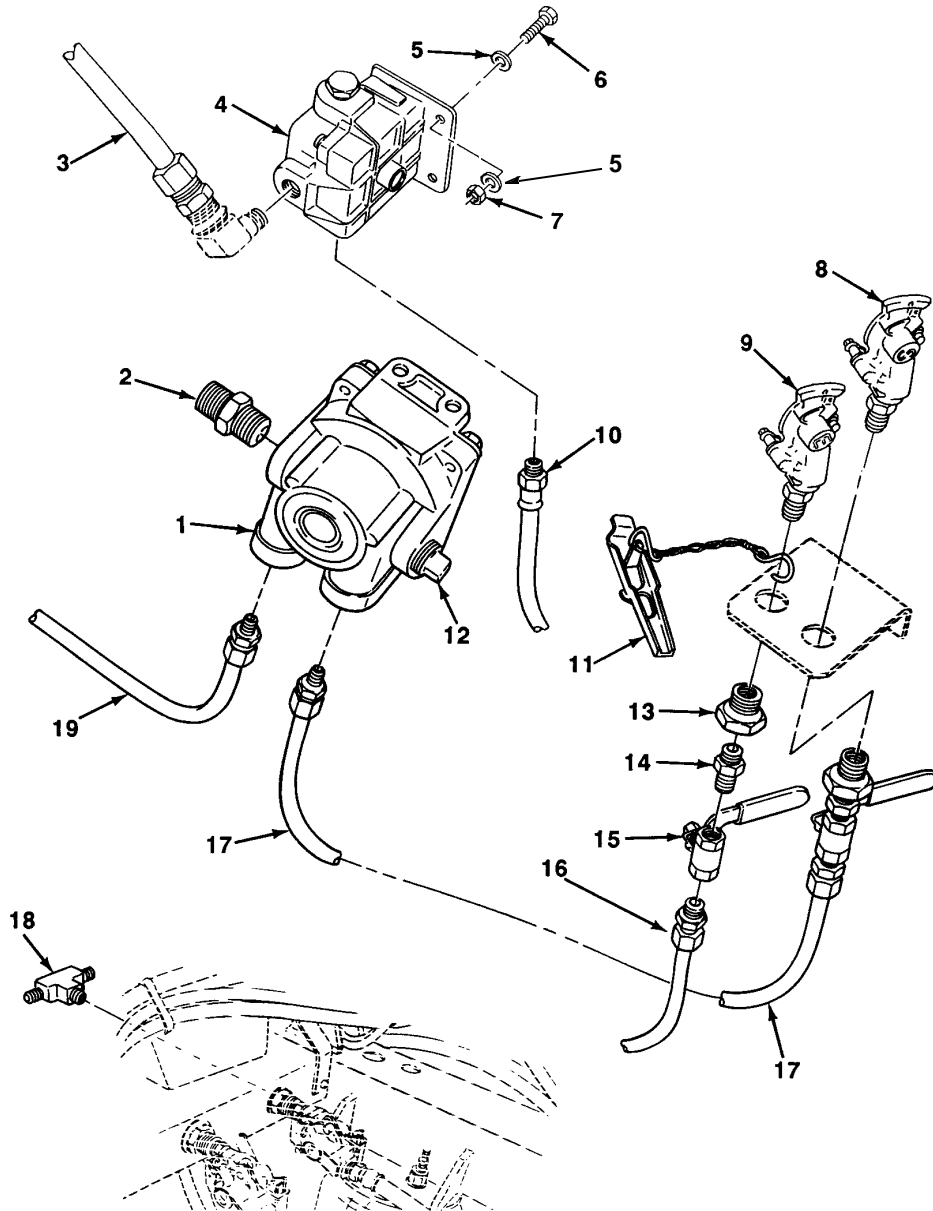


Figure 16. Airbrake Relay Valves, Lines, and Fittings, Rear.

(1) ITEM NO	(2) SMR CODE	(3) NSN	(4) CAGEC	(5) PART NUMBER	(6) DESCRIPTION AND USABLE ON CODES (UOC)	(7) QTY
<b>GROUP 1208 AIRBRAKE SYSTEM</b>						
<b>FIG. 16 AIRBRAKE RELAY VALVES, LINES, AND FITTINGS, REAR</b>						
1	PAOZZ	2530013937535	21439	8D00121-5	VALVE,RELAY,AIR PRE . . . . .	1
2	PAOZZ	4730005953108	50019	S1990	NIPPLE,PIPE . . . . .	7
3	PFOZZ	4710014061928	21439	8D00064-18	TUBE ASSEMBLY,METAL . . . . .	1
4	PFOZZ	2530014227473	21439	8D00121-8	VALVE,RELAY,AIR PRE . . . . .	1
5	PAOZZ	5310001670820	58051	AN960-516	WASHER,FLAT 5/16 . . . . .	4
6	PAOZZ	5306002258499	96906	MS90725-34	BOLT,MACHINE 5/16-18 X 1 . . . . .	2
7	PAOZZ	5310009843806	81349	M45913/1-5CG5C	NUT,SELF-LOCKING,HE 5/16-18 . . . . .	2
8	PAOZZ	4730005950083	58536	A52484-1	COUPLING HALF,QUICK . . . . .	2
9	PAOZZ	4730005950083	58536	A52484-1	COUPLING HALF,QUICK . . . . .	2
10	PFOZZ	4710014061927	21439	8D00064-17	TUBE ASSEMBLY,METAL . . . . .	1
11	PFOZZ	4820014234847	21439	8D00121-25	COUPLER,DUMMY . . . . .	2
12	PAOZZ	4730000113176	30780	1-2SHPB	PLUG,PIPE . . . . .	2
13	PAOZZ	4730004070571	93061	207ACBH-8	COUPLING,PIPE . . . . .	4
14	PAOZZ	4730002874852	93061	216P8-6	REDUCER,PIPE . . . . .	2
15	PAOZZ	4820013934552	21439	8D00121-2	COCK,DRAIN . . . . .	2
16	PFOZZ	4720013934580	21439	8D00064-10	HOSE ASSEMBLY,NONME . . . . .	1
17	PFOZZ	4710014061921	21439	8D00064-12	TUBE ASSEMBLY,METAL . . . . .	1
18	PFOZZ	4730002777331	93061	2203P-6	TEE,PIPE . . . . .	2
19	PAOZZ		21439	8D00064-13	TUBE ASSEMBLY,METAL . . . . .	1

END OF FIGURE

1	16
2 THRU 15	17 AND 18

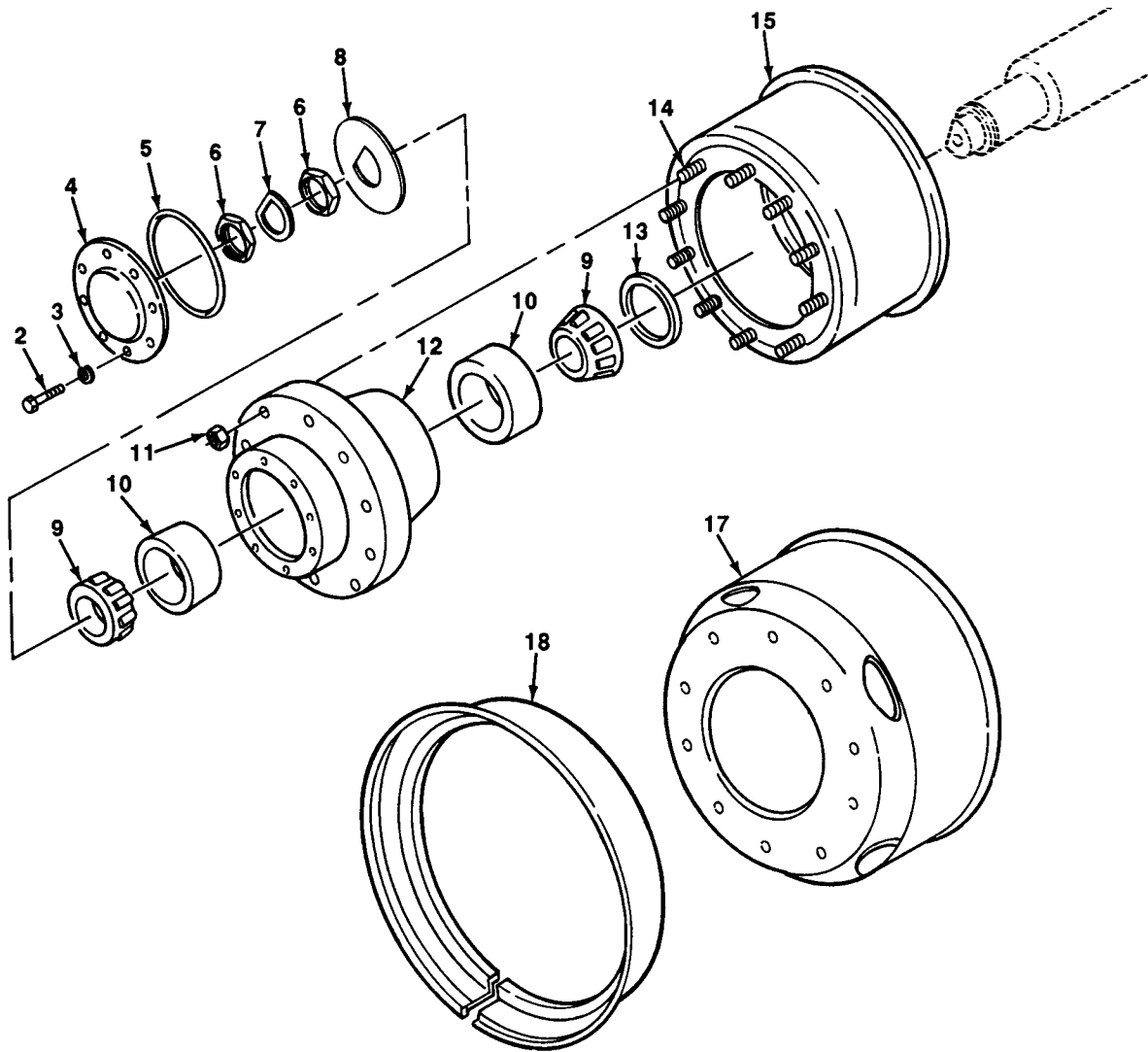


Figure 17. Hub, Drum, and Wheel.



(1) ITEM NO	(2) SMR CODE	(3) NSN	(4) CAGEC	(5) PART NUMBER	(6) DESCRIPTION AND USABLE ON CODES (UOC)	(7) QTY
<b>GROUP 13 WHEELS AND TRACKS</b>						
<b>GROUP 1311 WHEEL ASSEMBLY</b>						
<b>FIG. 17 HUB, DRUM, AND WHEEL</b>						
1	AOOFF		21439	8D00195-31	HUB AND DRUM ASSY R.H.....	1
1	AOOFF		21439	8D00195-41	HUB AND DRUM ASSY L.H.....	1
2	PAOZZ	5306000680513	18876	PMS90727001-06	.BOLT,MACHINE 1/4-28 X 3/4.....	8
3	PAOZZ	5310002748715	96906	MS35338-63	.WASHER,LOCK 1/4.....	8
4	PFOZZ	5340013932609	21439	8D00195-36	.COVER,ACCESS.....	1
5	PAOZZ	5331014180621	21439	8D00195-35	.O-RING.....	1
6	PFOZZ	5310014219481	21439	8D00195-40	.NUT,PLAIN,HEXAGON.....	2
7	PFOZZ	5310013935648	21439	8D00195-39	.WASHER,LOCK.....	1
8	PFOZZ	5310013935647	21439	8D00195-38	.WASHER,LOCK.....	1
9	PFOZZ	3110002938998	60038	HM212049	.CONE AND ROLLERS,TA.....	2
10	PFOZZ	3110013947718	21439	8D00195-55	.CUP,TAPERED ROLLER.....	2
11	PAOZZ	5310013942370	21439	8D00195-37	.NUT,PLAIN,HEXAGON R.H.....	10
11	PAOZZ	5310013935653	21439	8D00195-43	.NUT,PLAIN,HEXAGON L.H.....	10
12	PFOZZ	2530013935271	21439	8D00195-53	.HUB,WHEEL,VEHICULAR.....	1
13	PAOZZ	5330014649956	80201	35086	.SEAL,PLAIN.....	1
14	PFOZZ	5307013935652	21439	8D00195-56	.STUD,PLAIN R.H.....	10
14	PFOZZ	5307013936314	21439	8D00195-57	.STUD,PLAIN L.H.....	10
15	PFOZZ	2530013937543	21439	8D00195-54	.BRAKE DRUM.....	1
16	PAOZZ	2530006035768	19207	7388820	WHEEL,PNEUMATIC TIR.....	1
16	PAOZZ	2530013297523	73195	27404N	WHEEL DISC TUBELESS.....	1
17	XAOZZ		19207	7389493	.RIM,WHEEL,PNEUMATIC.....	1
18	PAOZZ	2530007389061	19207	7389061	.RING,SIDE,AUTOMOTIV.....	1

END OF FIGURE

1  
|  
2

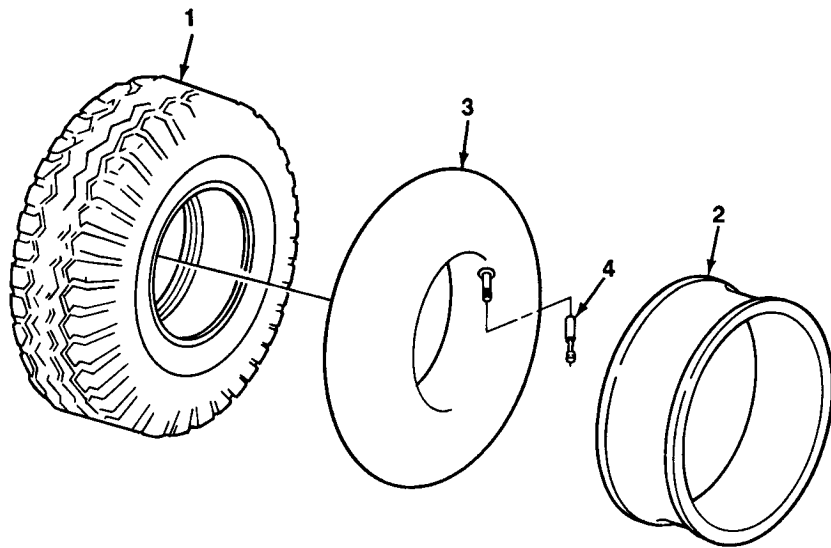


Figure 18. Tire and Tube.

(1) ITEM NO	(2) SMR CODE	(3) NSN	(4) CAGEC	(5) PART NUMBER	(6) DESCRIPTION AND USABLE ON CODES (UOC) GROUP 1313 TIRES, TUBES, TIRE CHAIN FIG. 18 TIRE AND TUBE	(7) QTY
1	PCOFH	2610012810675	04NP3	138382553	TIRE,PNEUMATIC,VEHI .....	1
1	PCOFH	2610012923009	22337	255-262	TIRE,PNEUMATIC,VEHI .....	1
					TUBELESS 12R22.5,UT 2000	
1	PCOFH	2610014655823	04NP3	138-864-554	TIRE,PNEUMATIC,VEHI .....	1
					2R22.5, G286 LRH	
1	PCOFH		12195	85335	TIRE,PNEUMATIC,VEHI .....	1
					TUBELESS 12R22.5,XZE LRH	
2	PAOZZ	2640001585617	19200	12009209	.FLAP,INNER TUBE,PNE .....	1
3	PAOZZ	2610000290563	91047	445205	INNER TUBE,PNEUMATIC .....	1
4	PAOZZ	2640010932842	79934	TR78A	VALVE,PNEUMATIC TIRE .....	1
4	PAOZZ	2640005552824	27783	TR573	VALVE,PNEUMATIC TIR TUBELESS.....	1
END OF FIGURE						

8	9
9 THRU 16	10 THRU 12

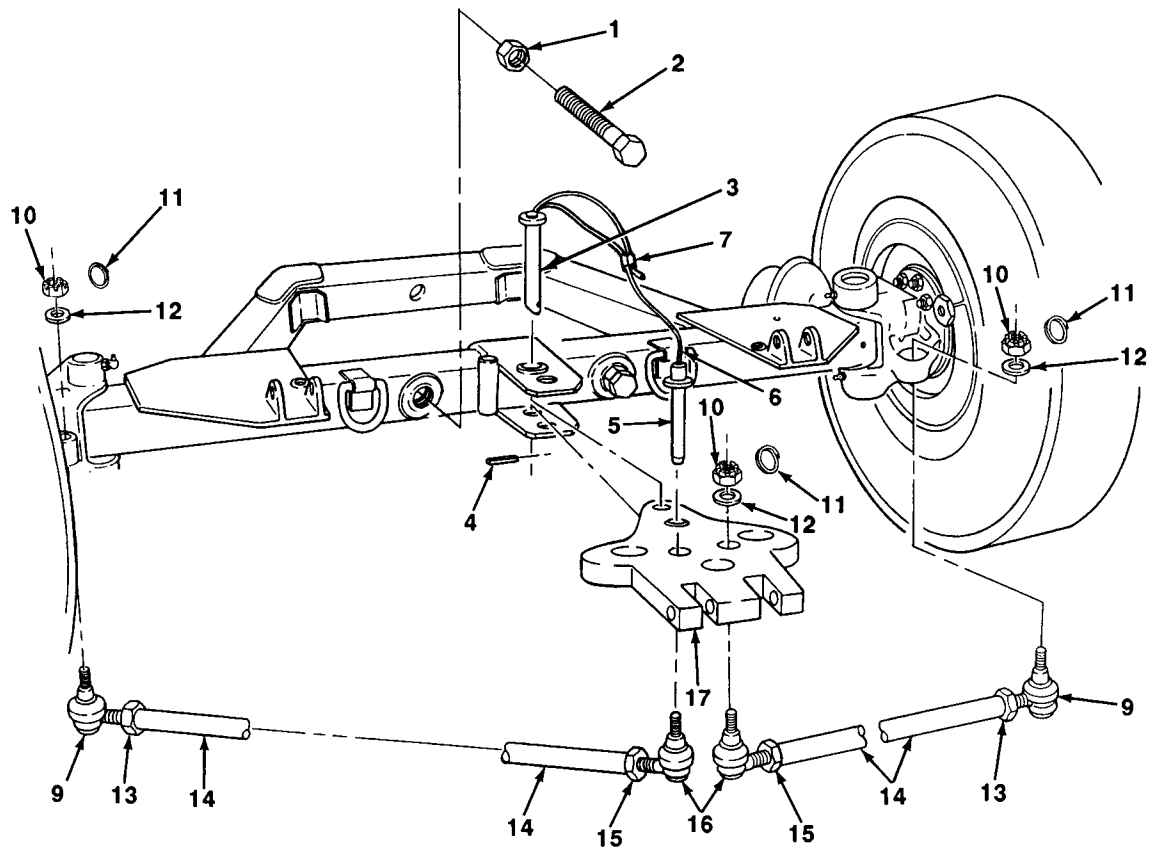


Figure 19. Steering Arm and Tie-Rods.

(1) ITEM NO	(2) SMR CODE	(3) NSN	(4) CAGEC	(5) PART NUMBER	(6) DESCRIPTION AND USABLE ON CODES (UOC)	(7) QTY
<b>GROUP 14 STEERING</b>						
<b>GROUP 1401 MECHANICAL STEERING GEAR ASSEMBLY</b>						
<b>FIG. 19 STEERING ARM AND TIE-RODS</b>						
1	PFOZZ	5310013936313	21439	8D00195-45	NUT,PLAIN,HEXAGON 1-8 . . . . .	2
2	PAOZZ	5306014303411	21439	8D00195-46	BOLT,MACHINE 1-8 X 2 1/2 . . . . .	2
3	PFOZZ	5315013931318	21439	8D00195-58	PIN,STRAIGHT,HEADLE . . . . .	1
4	XDOZZ		21439	8D00195-59	PIN,SPRING . . . . .	1
5	PAOZZ	5315014732046	1NHH8	8D00195-44	PIN,STRAIGHT,HEADED . . . . .	1
6	PFOZZ	2590014281697	21439	8D00195-70	CABLE ASSEMBLY,CONT . . . . .	1
7	PAOZZ	4730014216441	21439	8D00195-66	SLEEVE,CLINCH,TUBE . . . . .	2
8	PAOZZ		21439	8D00195-19	TIE ROD END,STEERING . . . . .	2
9	PAOZZ	2530013937545	21439	8D00195-20	.TIE ROD END,STEERING . . . . .	1
10	PAOZZ	5310014195660	21439	8D00195-72	..NUT,PLAIN,HEXAGON. . . . .	1
11	PAOZZ		21439	8D00195-73	..PIN,COTTER,CIRCLE . . . . .	1
12	PFOZZ		21439	8D00195-74	..WASHER,FLAT. . . . .	1
13	PFOZZ	5310013935644	21439	8D00195-21	.WASHER,LOCK 1-16. . . . .	1
14	XAOZZ		21439	8D00195-22	.TIE-ROD . . . . .	1
15	PFOZZ	5310013935649	21439	8D00195-23	.NUT,PLAIN,HEXAGON 1-16 . . . . .	1
16	PAOZZ		21439	8D00195-24	.TIE ROD END,STEERIN. . . . .	1
17	PFOZZ	2530013935173	21439	8D00195-7	ARM,STEERING GEAR . . . . .	1

END OF FIGURE

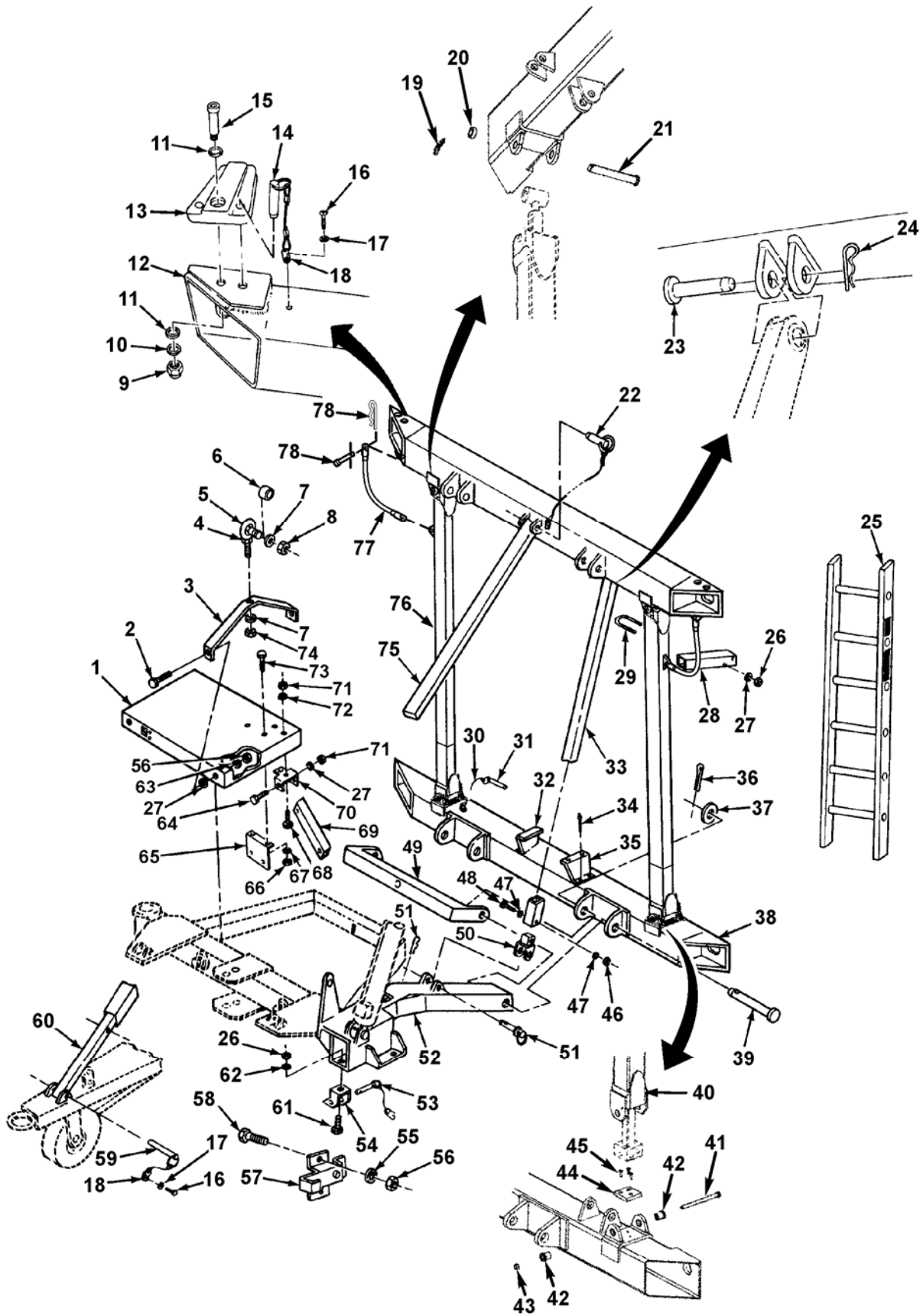


Figure 20. Frame Components

(1) ITEM NO	(2) SMR CODE	(3) NSN	(4) CAGEC	(5) PART NUMBER	(6) DESCRIPTION AND USABLE ON CODES (UOC)	(7) QTY
<b>GROUP 15 FRAME, TOWING ATTACHMENTS, DRAWBARS, AND ARTICULATION SYSTEMS</b>						
<b>GROUP 1501 FRAME ASSEMBLY</b>						
<b>FIG. 20 FRAME COMPONENTS</b>						
1	PFOZZ	2510013932666	21439	8D00073-1	TRAY,PIVOTING FRONT.....	1
1	PFOZZ	2510013935870	21439	8D00125-1	TRAY,PIVOTING REAR.....	1
2	PAOZZ	5305008810705	80205	MS51975-17	SCREW,SHOULDER 3/8 X 5/8.....	4
3	PFOZZ	2590013935873	21439	8D00073-2	BRACKET,VEHICULAR C FRONT.....	2
3	PFOZZ	2590013937531	21439	8D00125-2	BRACKET,VEHICULAR C REAR.....	2
4	PAOZZ	5310001671304	81352	AN316-8R	NUT,PLAIN,HEXAGON 1/2-20.....	2
5	PFOZZ	3120013947284	56644	CM8SZ	BEARING,PLAIN,ROD E.....	2
6	PFOZZ	5365013930841	21439	8D00110-33	SPACER,SLEEVE..... USE WITH REAR TRAY ONLY	2
7	PAOZZ	5310001670823	88044	AN960-816	WASHER,FLAT 1/2.....	4
8	PAOZZ	5310008775795	96906	MS21044-N8	NUT,SELF-LOCKING,HE 1/2-20.....	2
9	PAOZZ	5310002694040	81349	M45913/1-10CG5C	NUT,SELF-LOCKING,HE 5/8-11.....	2
10	PAOZZ	5310001670825	88044	AN960-1016	WASHER,FLAT 5/8.....	2
11	PAOZZ	5310001670826	88044	AN960-1216	WASHER,FLAT 3/4.....	4
12	PBOZZ	3940015362137	19207	12501505	FRAME SECTION,STRUC FRONT.....	1
12	PBOZZ	3940015434246	19207	12501508	FRAME SECTION,STRUC REAR.....	1
13	PBOZZ	2590013935871	21439	8D00081-1	HOOK,HOLD-DOWN,TRAI.....	2
14	PAOZZ	5315014192308	21439	8D00202-1	PIN,QUICK RELEASE.....	2
15	PAOZZ	5305008585558	80205	MS51975-55	SCREW,SHOULDER 3/4 X 2.....	2
16	PAOZZ	5305000581082	96906	MS51861-34	SCREW,TAPPING #8 X 1/4.....	6
17	PAOZZ	5310000453299	96906	MS35338-42	WASHER,LOCK #8.....	6
18	PFOZZ	3990014188755	96652	79-07	WIRE,PIN RETAINER.....	5
19	PAOZZ	5315010548531	19207	12501530	PIN,COTTER.....	4
20	PAOZZ	5365015054642	19207	12501539	SPACER.....	4
21	PAOZZ	5315015423873	19207	12501531	PIN,CLEVIS.....	4
22	PFOZZ	5315013947523	21439	8D00202-3	PIN,QUICK RELEASE.....	1
23	PAOZZ	5315013929397	21439	8D00060-1	PIN,STRAIGHT,HEADED.....	2
24	PAOZZ	5315011710750	96652	21-09	PIN,LOCK.....	2
25	PFOZZ	2540014185567	21439	8D00231-1	LADDER,VEHICLE BOAR.....	1
26	PAOZZ	5310000874652	96906	MS51922-17A	NUT,SELF-LOCKING,HE 3/8-16.....	6
27	PAOZZ	5310001670821	88044	AN960-616	WASHER,FLAT 3/8.....	9
28	PFOZZ	2590014227462	21439	8D00217-1	BRACKET,VEHICULAR C.....	2
29	PFOZZ	5306014175740	0EXZ4	8D00227-1	BOLT,U.....	2
30	PFOZZ	3990014188756	96652	79-08	LANYARD ASSY.....	1

## Section II

## TM 9-2330-390-14&amp;P, C5

(1) ITEM NO	(2) SMR CODE	(3) NSN	(4) CAGEC	(5) PART NUMBER	(6) DESCRIPTION AND USABLE ON CODES (UOC)	(7) QTY
31	PFOZZ	5315013947522	21439	8D00202-4	PIN,QUICK RELEASE .....	1
32	PFOZZ	5340013937083	21439	8D00207-1	BRACKET,MOUNTING .....	1
33	PAOZZ	4710013944780	21439	8D00061-1	TUBE,BRACE,CHASSIC.....	2
34	PFOZZ	5320013930842	05693	CR3213-8-08	RIVET,BLIND.....	4
35	PFOZZ	5340013939366	21439	8D00207-2	BRACKET,DOUBLE ANGL .....	1
36	PAOZZ	5315002341673	96906	MS24665-688	PIN,COTTER .....	2
37	PFOZZ	5310009020423	96906	MS15795-835	WASHER,FLAT .....	6
38	PBOZZ	3940015424245	19207	12501507	FRAME,STRUCTURAL,VE FRONT.....	1
38	PBOZZ	3940015424243	19207	12501504	FRAME SECTION,STRUC REAR .....	1
39	PAOZZ	5315013929395	21439	8D00060-7	PIN,STRAIGHT,HEADED .....	2
40	PBOZZ	3040015424036	19207	12501509	TUBE,LOWER VERTICAL .....	4
41	PAOZZ	5305015054928	19207	12501533	SCREW,CAP,HEXAGON H .....	4
42	PAOZZ	3120015054227	19207	12501523	BUSHING,SLEEVE.....	8
43	PAOZZ	5310015050271	19207	12501532	NUT,PLAIN,EXTENDED HE .....	4
44	PAOZZ	5365015424047	19207	12501516	SHIM.....	4
45	PAOZZ	5305015050584	19207	12501538	BOLT .....	12
46	PAOZZ	5310000874652	96906	MS51922-17A	.NUT,SELF-LOCKING,HE .....	1
47	PAOZZ	5310001670821	88044	AN960-616	.WASHER,FLAT .....	2
48	PAOZZ	5305002693217	96906	MS90725-67	.SCREW,CAP,HEXAGON H .....	1
49	PBOZZ	4710013944779	21439	8D00079-1	TUBE,METALLIC FRONT.....	1
49	PBOZZ	5340013936786	21439	8D00079-2	BRACKET,DOUBLE ANGL REAR .....	1
50	PFOZZ	5340014324862	21439	8D00061-6	.CONNECTOR,ROD END .....	1
51	PAOZZ	5315014247838	21439	8D00077-41	PIN,STRAIGHT,HEADLE.....	2
52	PBFZZ	3040013935240	21439	8D00080-1	CONNECTING LINK,RIG R.H.....	1
52	PBFZZ	3040013935243	21439	8D00080-2	CONNECTING LINK,RIG L.H.....	1
52	PBFZZ	3040013935251	21439	8D00119-1	CONNECTING LINK,RIG R.H.....	1
52	PBFZZ	3040013935258	21439	8D00119-2	CONNECTING LINK,RIG L.H.....	1
53	PAOZZ	5315014297277	21439	8D00341-1	PIN,QUICK RELEASE .....	1
54	PFOZZ	2590013935273	21439	8D00204-1	BRACKET,VEHICULAR C.....	1
55	PAOZZ	5310001670820	58051	AN960-516	WASHER,FLAT 5/16.....	4
56	PAOZZ	5310009843806	81349	M45913/1-5CG5C	NUT,SELF-LOCKING,HE 5/16-18 .....	8
57	PFOZZ	5340013937079	21439	8D00121-7	CLIP,SPRING TENSION.....	2
58	PAOZZ	5306002258498	96906	MS90725-33	BOLT,MACHINE 5/16-18 X 7/8.....	4
59	PFOZZ	5315013947521	21439	8D00202-2	PIN,QUICK RELEASE .....	2
60	PFOZZ	2510013935168	21439	8D00102-1	FRAME SECTION,STRUC .....	1
61	PAOZZ	5305002693211	96906	MS90725-60	SCREW,CAP,HEXAGON H 3/8-16 X 1 .....	2
62	PAOZZ	5310007737618	96906	MS15795-814	WASHER,FLAT 3/8 .....	2
63	PAOZZ	5310000446477	96906	MS51412-25	WASHER,FLAT 7/16.....	4



## Section II

## TM 9-2330-390-14&amp;P, C5

(1) ITEM NO	(2) SMR CODE	(3) NSN	(4) CAGEC	(5) PART NUMBER	(6) DESCRIPTION AND USABLE ON CODES (UOC)	(7) QTY
64	PAOZZ	5305002693219	96906	MS90725-69	SCREW,CAP,HEXAGON H 3/8-16 X 2 3/4 .....	1
65	PFOZZ	5340013935650	21439	8D00125-3	BRACKET,ANGLE REAR ONLY .....	1
66	PAOZZ	5310000881251	81349	M45913/1-4CG5C	NUT,SELF-LOCKING,HE 1/4-20.....	2
67	PAOZZ	5310001411795	88044	AN960-416	WASHER,FLAT 1/4 .....	2
68	PAOZZ	5305002693211	96906	MS90725-60	SCREW,CAP,HEXAGON H 3/8-16 X 1 .....	2
69	PFOZZ	5340013934865	21439	8D00205-1	BRACKET,MOUNTING.....	1
70	PFOZZ	5340013931862	21439	8D00203-1	BRACKET,DOUBLE ANGL.....	1
71	PAOZZ	5310000874652	96906	MS51922-17	NUT,SELF-LOCKING,HE 3/8-16 .....	3
72	PAOZZ	5310000806004	96906	MS27183-14	WASHER,FLAT 13/32 .....	2
73	PAOZZ	5305000712505	80204	B1821BH025C088 N	SCREW,CAP,HEXAGON H 1/4-20 X 7/8	2
74	PAOZZ	5310004492376	96906	MS21245-8	NUT,SELF-LOCKING,HE 1/2-20.....	2
75	PFOZZ	2510013935091	21439	8D00102-2	FRAME SECTION,STRUC .....	1
76	PBOZZ	3040015424039	19207	12501510	TUBE,UPPER VERTICAL LEFT.....	2
76	PBOZZ	3040015424043	19207	12501511	TUBE,UPPER VERTICAL RIGHT .....	2
77	PAOZZ	4010015429978	19207	12501535	LANYARD,CABLE ASSEMBLY .....	4
78	PAOZZ	5315015429980	3A054	97245A709	·PIN,KIT .....	2

END OF FIGURE

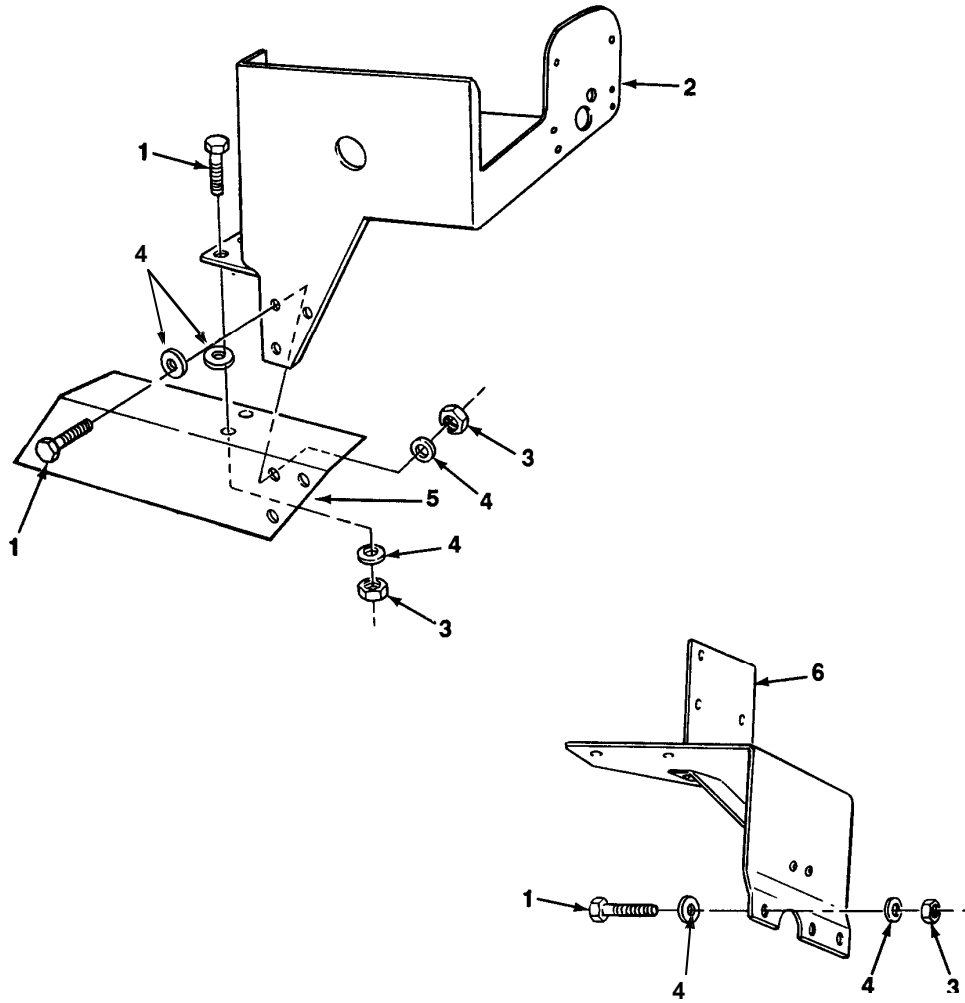


Figure 21. Miscellaneous Brackets.

(1) ITEM NO	(2) SMR CODE	(3) NSN	(4) CAGEC	(5) PART NUMBER	(6) DESCRIPTION AND USABLE ON CODES (UOC)	(7) QTY
<b>GROUP 1501 FRAME ASSEMBLY</b>						
<b>FIG. 21 MISCELLANEOUS BRACKETS</b>						
1	PAOZZ	5305002693211	96906	MS90725-60	SCREW,CAP,HEXAGON H 3/8-16 X 1 .....	12
2	PFOZZ	5340014177276	21439	8D00212-1	BRACKET,MOUNTING L.H.....	1
2	PFOZZ	6220013935111	21439	8D00067-1	BRACKET,LIGHT RETEN R.H .....	1
3	PAOZZ	5310000874652	96906	MS51922-17	NUT,SELF-LOCKING,HE 3/8-16.....	12
4	PAOZZ	5310007737618	96906	MS15795-814	WASHER,FLAT 3/8 .....	24
5	PFOZZ	5340014177277	21439	8D00068-1	BRACKET,MOUNTING R.H.....	1
5	PFOZZ	5340013937082	21439	8D00068-2	BRACKET,MOUNTING L.H.....	1
6	PFOZZ	5340013936788	21439	8D00215-1	BRACKET,MOUNTING L.H.....	1
6	PFOZZ	2590014063526	21439	8D00214-1	BRACKET,VEHICULAR C R.H .....	1

END OF FIGURE

12  
|  
13 THRU 15

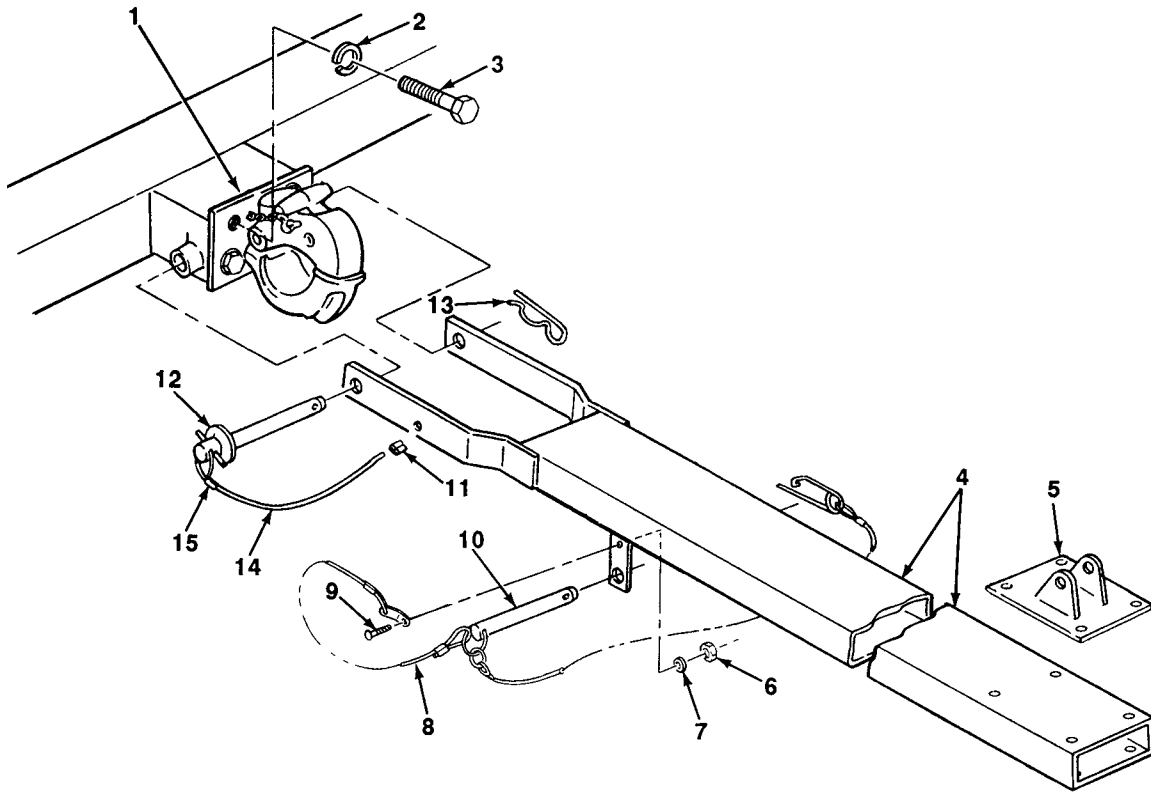


Figure 22. Pintle Assembly and Rear Drawbar.

(1) ITEM NO	(2) SMR CODE	(3) NSN	(4) CAGEC	(5) PART NUMBER	(6) DESCRIPTION AND USABLE ON CODES (UOC)	(7) QTY
<b>GROUP 1503 PINTLES AND TOWING ATTACHMENTS</b>						
<b>FIG. 22 PINTLE ASSEMBLY AND REAR DRAWBAR</b>						
1	PAOZZ	2540008359039	96906	MS51335-2	PINTLE ASSEMBLY,TOW .....	1
2	PAOZZ	5310005845272	96906	MS35338-48	WASHER,LOCK 1/2 .....	4
3	PAOZZ	5305000444153	96906	MS90725-109	SCREW,CAP,HEXAGON H 1/2-13 X 1 .....	4
4	PFOZZ	2540013937534	21439	8D00131-1	DRAWBAR,POLE TRAILER .....	1
5	PFOZZ	2590014185571	21439	8D00222-1	BRACKET,VEHICULAR C .....	1
6	PAOZZ	5310008113494	96906	MS21044-N08	NUT,SELF-LOCKING,HE #8-32 .....	1
7	PAOZZ	5310005158058	88044	AN960-8	WASHER,FLAT 5/32 .....	1
8	PAOZZ	3990014188755	96652	79-07	WIRE,PIN RETAINER .....	1
9	PAOZZ	5305009846195	96906	MS35206-247	SCREW,MACHINE #8-32 X 3/4 .....	1
10	PAOZZ	5315014297277	21439	8D00341-1	PIN,QUICK RELEASE .....	1
11	PFOZZ	4730014216441	21439	8D00195-66	SLEEVE,CLINCH,TUBE .....	1
12	PFOZZ	5315013931319	52793	05-047571	PIN,STRAIGHT,HEADLE .....	1
13	PFOZZ	5325013174273	21439	8D00195-71	.RING,RETAINING .....	1
14	PFOZZ	2590014281697	21439	8D00195-70	.CABLE ASSEMBLY,CONT .....	1
15	PFOZZ	4730014216441	21439	8D00195-66	.SLEEVE,CLINCH,TUBE .....	1

END OF FIGURE

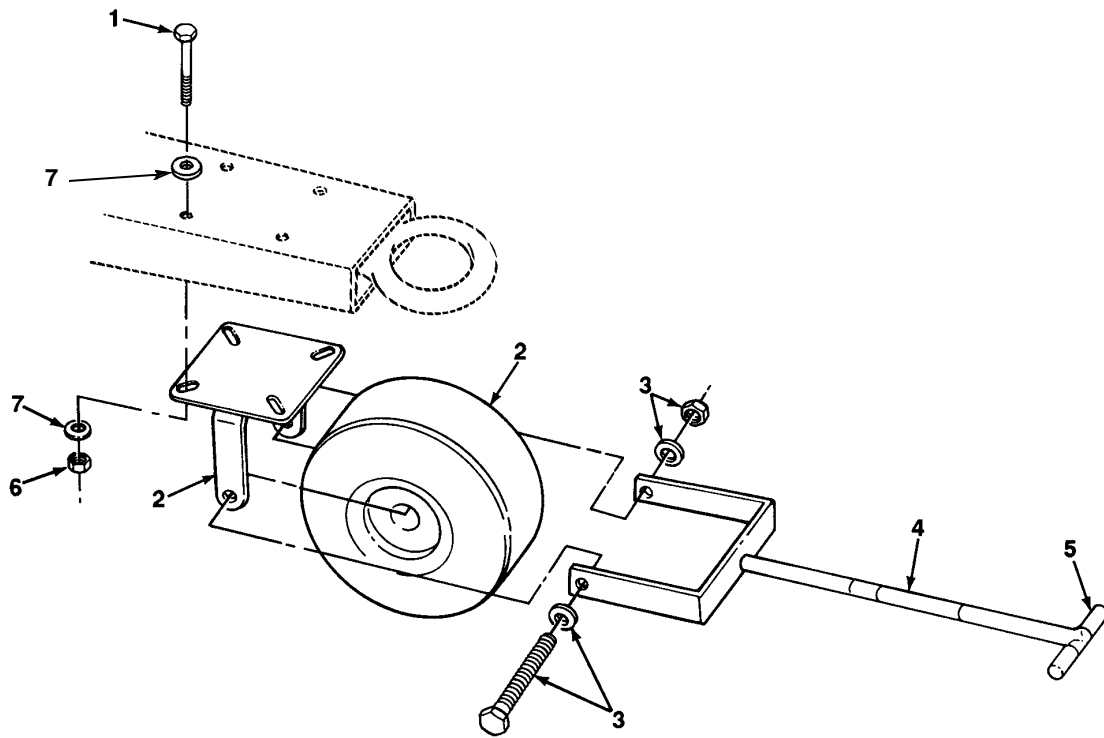


Figure 23. Caster Wheel Assembly.

(1) ITEM NO	(2) SMR CODE	(3) NSN	(4) CAGEC	(5) PART NUMBER	(6) DESCRIPTION AND USABLE ON CODES (UOC)	(7) QTY
<b>GROUP 1507 LANDING GEAR, LEVELING JACKS</b>						
<b>FIG. 23 CASTER WHEEL ASSEMBLY</b>						
1	PAOZZ	5305000712078	96906	MS90725-122	SCREW,CAP,HEXAGON H 1/2-13 X 3-3/4 . . . . .	4
2	PFOZZ	5340013931315	21439	8D00088-1	CASTER,SWIVEL. . . . .	1
3	PFOZZ		26935	506.5G2	MOUNTING KIT CASTER WHEEL . . . . .	1
4	PFOZZ	2540013937972	21439	8D00087-1	HANDLE,TOWBAR,MOTOR . . . . .	1
5	PFOZZ	5340013940005	15819	LC1.37X5.00	GRIP,HANDLE . . . . .	2
6	PAOZZ	5310002256993	81349	M45913/1-8CG5C	NUT,SELF-LOCKING,HE 1/2-13. . . . .	4
7	PAOZZ	5310007679425	96906	MS15795-818	WASHER,FLAT 1/2 . . . . .	8

END OF FIGURE

3  
|  
4

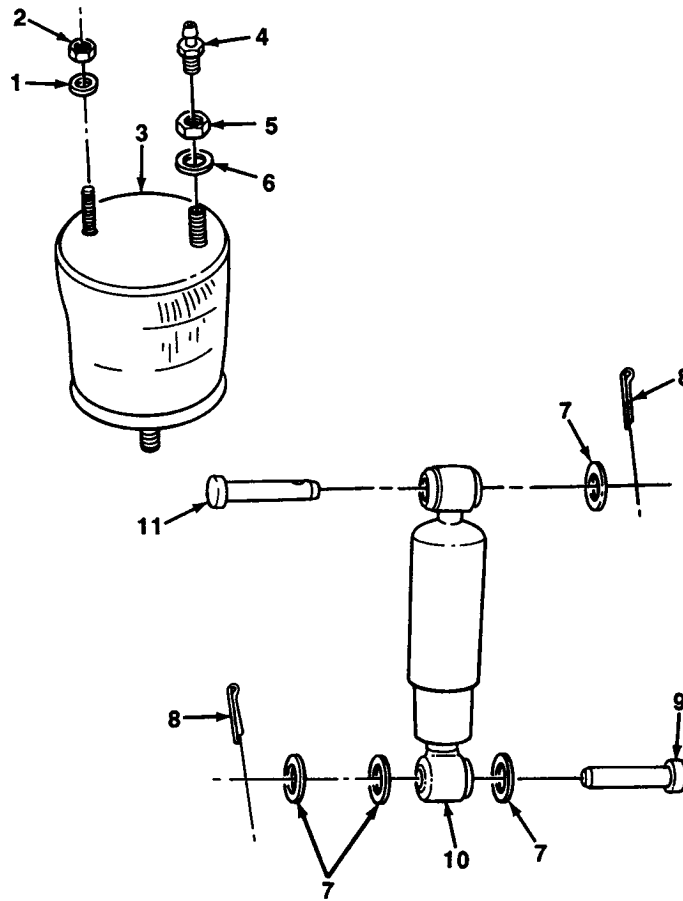


Figure 24. Shock Absorber, Air Bag, and Mounting Hardware.



(1) ITEM NO	(2) SMR CODE	(3) NSN	(4) CAGEC	(5) PART NUMBER	(6) DESCRIPTION AND USABLE ON CODES (UOC)	(7) QTY
<b>GROUP 16 SPRINGS AND SHOCK ABSORBER</b>						
<b>GROUP 1604 SHOCK ABSORBER EQUIPMENT</b>						
<b>FIG. 24 SHOCK ABSORBER, AIR BAG, AND MOUNTING HARDWARE</b>						
1	PAOZZ	5310012671685	96906	MS51412-8	WASHER,FLAT 1/2 . . . . .	1
2	PAOZZ	5310002256993	81349	M45913/1-8CG5C	NUT,SELF-LOCKING,HE 1/2-13. . . . .	1
3	PBOZZ	2510013936526	0NTD7	1R11-094	AIR BAG,VEHICULAR . . . . .	1
4	PAOZZ	4820014218062	0NTD7	578-92-9-122	.VALVE,PNEUMATIC TAN . . . . .	1
5	PAOZZ	5310008329719	81349	M45913/2-12FG5C	NUT,SELF-LOCKING,HE 3/4-16. . . . .	2
6	PAOZZ	5310001670826	88044	AN960-1216	WASHER,FLAT 3/4 . . . . .	1
7	PAOZZ	5310001670828	88044	AN960-1616	WASHER,FLAT 1 IN . . . . .	4
8	PAOZZ	5315002341664	96906	MS24665-495	PIN,COTTER . . . . .	2
9	PAOZZ	5315013928539	21439	8D00060-4	PIN,STRAIGHT,HEADED. . . . .	1
10	PAOZZ	2510013935259	21439	8D00059-1	SHOCK ABSORBER,DIRE. . . . .	1
11	PAOZZ	5315013929393	21439	8D00060-5	PIN,STRAIGHT,HEADED FRONT. . . . .	1
11	PAOZZ	5315013928542	21439	8D00060-6	PIN,STRAIGHT,HEADED REAR. . . . .	1

END OF FIGURE

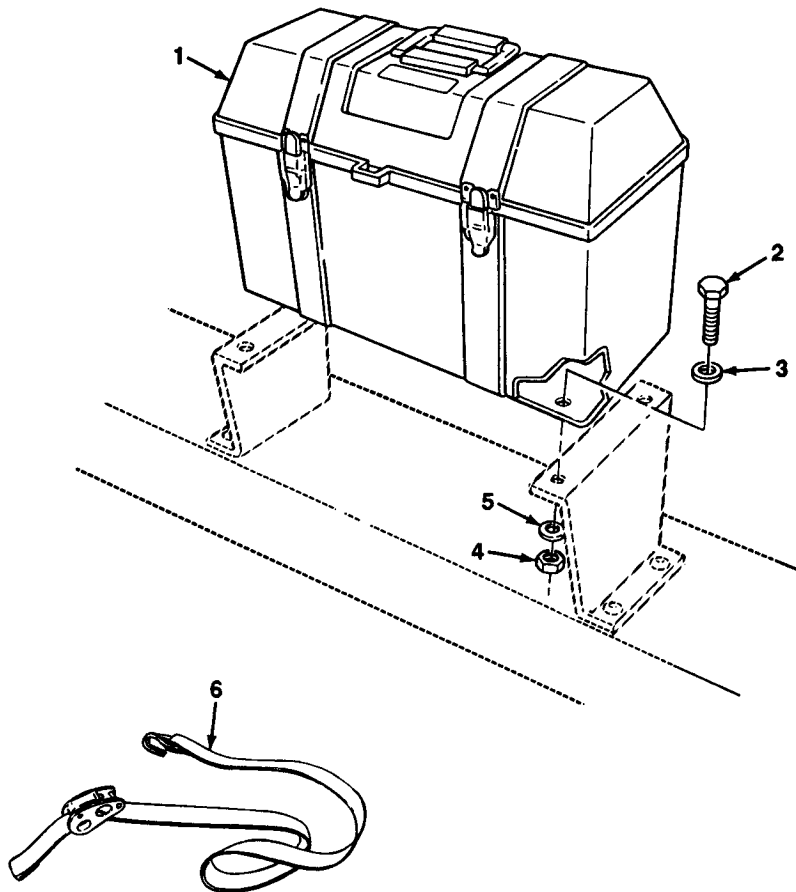


Figure 25. Toolbox.

(1) ITEM NO	(2) SMR CODE	(3) NSN	(4) CAGEC	(5) PART NUMBER	(6) DESCRIPTION AND USABLE ON CODES (UOC)	(7) QTY
<b>GROUP 18 BODY, CAB, HOOD, AND HULL</b>						
<b>GROUP 1808 STOWAGE RACKS, BOXES, STRAPS, CARRYING CASES, CABLE REELS, HOSE REELS, ETC.</b>						
<b>FIG. 25 TOOLBOX</b>						
1	PFOZZ	5140013942021	21439	8D00114-1	TOOL BOX,PORTABLE . . . . .	1
2	PAOZZ	5305002253843	96906	MS90728=8	SCREW,CAP,HEXAGON H 1/4-20 X 1 . . . . .	4
3	PAOZZ	5330001718363	83259	600-015-1-4	PACKING WITH RETAIN . . . . .	4
4	PAOZZ	5310000881251	81349	M45913/1-4CG5C	NUT,SELF-LOCKING,HE 1/4-20 . . . . .	4
5	PAOZZ	5310005825677	96906	MS15795-810	WASHER,FLAT 1/4 . . . . .	4
6	PAOZZ	3990014214290	21439	8D00223-1	TIE DOWN,CARGO,VEHICLE . . . . .	6

END OF FIGURE

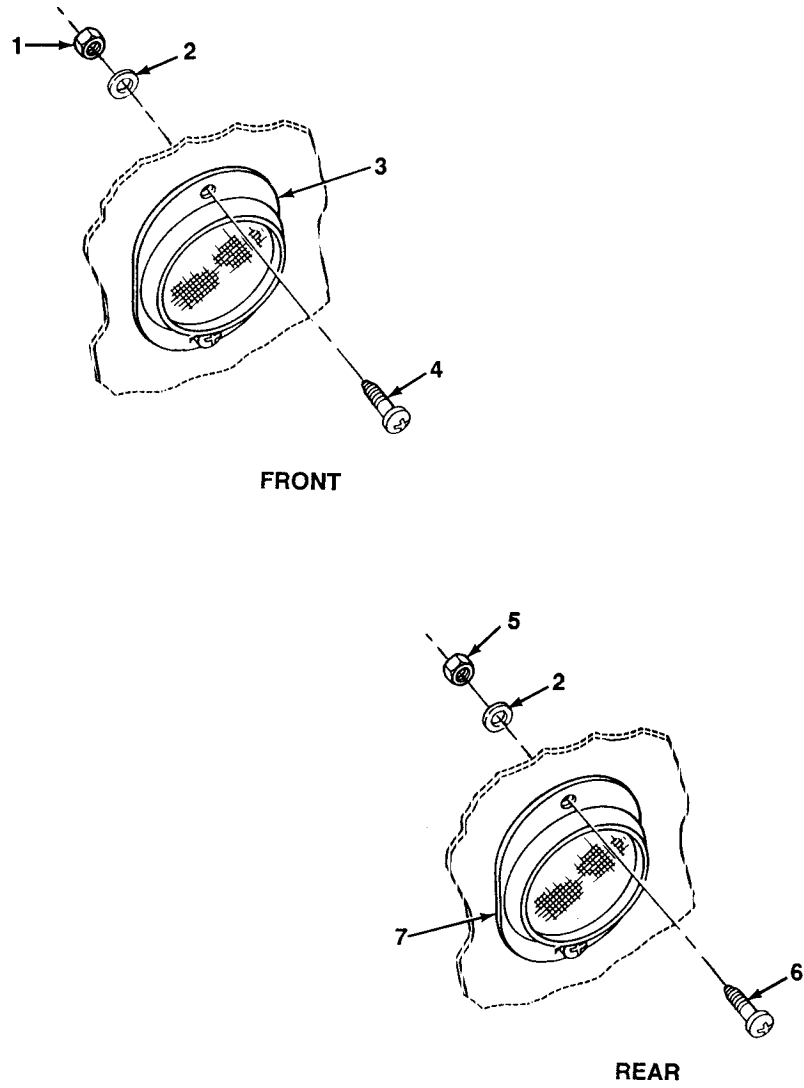


Figure 26. Reflectors.

(1) ITEM NO	(2) SMR CODE	(3) NSN	(4) CAGEC	(5) PART NUMBER	(6) DESCRIPTION AND USABLE ON CODES (UOC)	(7) QTY
<b>GROUP 22 BODY, CHASSIS, AND HULL ACCESSORY ITEMS</b>						
<b>GROUP 2202 ACCESSORY ITEMS</b>						
<b>FIG. 26 REFLECTORS</b>						
1	PAOZZ	5310008976145	96906	MS21083-C4	NUT,SELF-LOCKING,HE 1/4-28 L.H. ....	2
2	PAOZZ	5310013048733	96906	MS15795-852	WASHER,FLAT 1/4 .....	4
3	PAOZZ	9905002023639	96906	MS35387-2	REFLECTOR,INDICATIN AMBER. ....	1
4	PAOZZ	5305000595432	96906	MS51958-82	SCREW,MACHINE 1/4-28 X 7/8 R.H. ....	2
4	PAOZZ	5305000593676	96906	MS51958-80	SCREW,MACHINE 1/4-28 X 5/8 L.H. ....	2
5	PAOZZ	5310008892589	96906	MS21044C4	NUT,SELF-LOCKING,HE 1/4-28 R.H. AND REAR ....	2
6	PAOZZ	5305000593677	96906	MS51958-81	SCREW,MACHINE 1/4-28 X 3/4 .....	2
7	PAOZZ	9905002052795	96906	MS35387-1	REFLECTOR,INDICATIN RED .....	1

END OF FIGURE

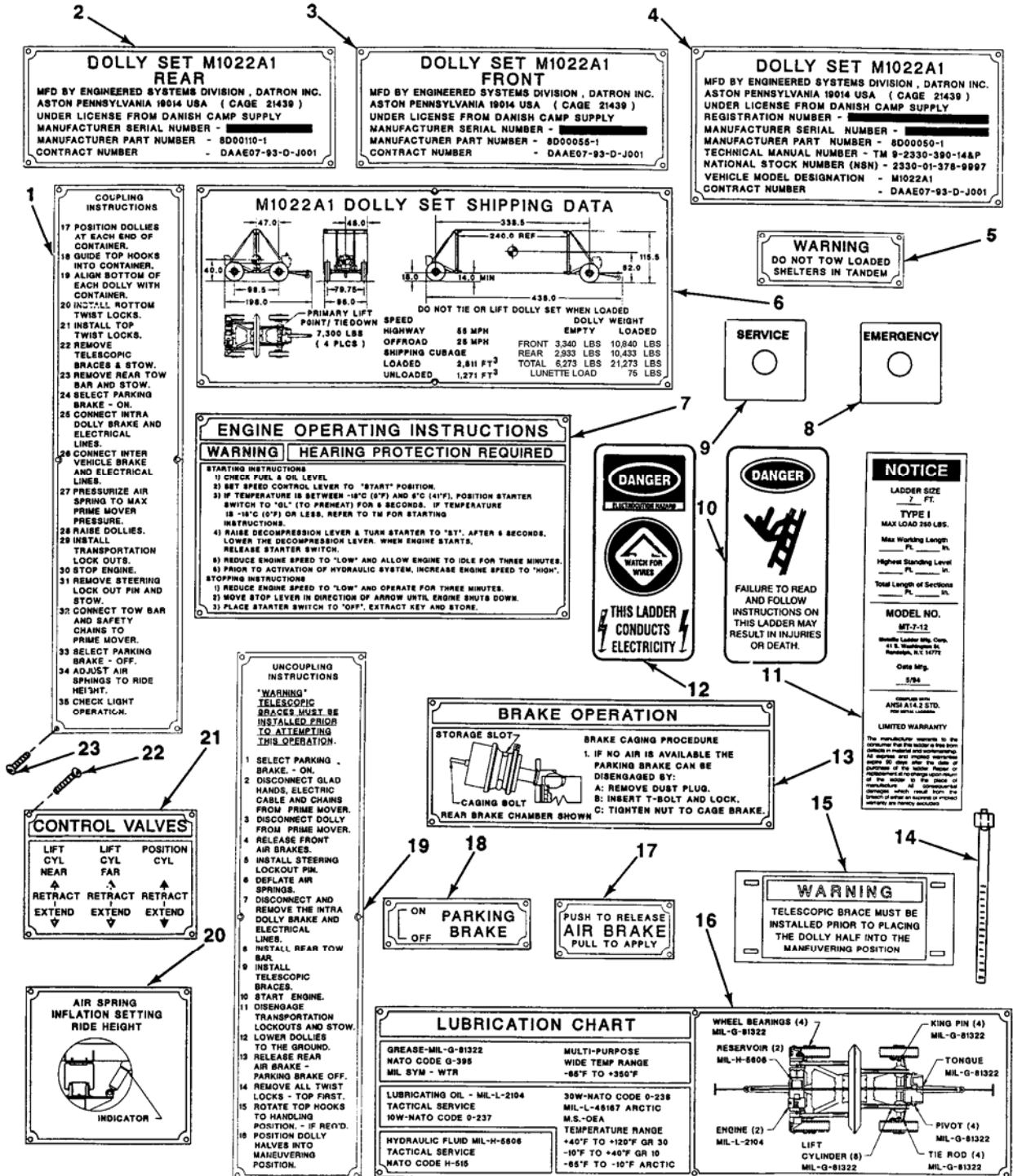


Figure 27. Data Plates

(1) ITEM NO	(2) SMR CODE	(3) NSN	(4) CAGEC	(5) PART NUMBER	(6) DESCRIPTION AND USABLE ON CODES (UOC)	(7) QTY
<b>GROUP 2210 DATA PLATES AND INSTRUCTION HOLDERS</b>						
<b>FIG. 27 DATA PLATES</b>						
1	PAOZZ	9905013952089	21439	8D00062-20	PLATE,INSTRUCTION.....	2
2	PAOZZ	9905013949845	21439	8D00062-8	PLATE,INSTRUCTION.....	1
3	PAOZZ	9905013949843	21439	8D00062-7	PLATE,INSTRUCTION.....	1
4	PAOZZ	9905013949841	21439	8D00062-6	PLATE,INSTRUCTION.....	1
5	PAOZZ	9905013949853	21439	8D00062-16	PLATE,INSTRUCTION.....	1
6	PAOZZ	9905015429894	19207	12501541	PLATE,INSTRUCTION.....	1
7	PFOZZ	9905014211714	21439	8D00062-21	PLATE,IDENTIFICATIO REAR.....	1
7	PFOZZ	7690014318645	21439	8D00062-28	LABEL FRONT.....	1
8	PFOZZ	9905009997369	58536	A-A-52483	PLATE,IDENTIFICATION.....	1
9	PFOZZ	9905009997370	96906	MS53007-1	PLATE,IDENTIFICATION.....	1
10	PFOZZ	7690014185084	93957	ALI-00-C	LABEL.....	1
11	PFOZZ	7690014173461	93957	ALI-23	LABEL.....	1
12	PFOZZ	7690014173455	93957	ALI-6	LABEL.....	1
13	PAOZZ	9905013952713	21439	8D00062-19	PLATE,INSTRUCTION.....	1
14	PAOZZ	5340012883093	06383	MLT6H-LP	STRAP,LINE SUPPORTI..... FOR USE WITH SIDE LIFT CYLINDER	4
14	PFOZZ	5975013566962	06383	MLT4H-LP	STRAP,TIEDOWN,ELECT..... FOR USE WITH STANDARD LIFT CYLINDER	4
15	PFOZZ	7690014318642	21439	8D00062-26	LABEL.....	1
16	PAOZZ	9905013952712	21439	8D00062-13	PLATE,INSTRUCTION.....	1
17	PAOZZ	9905013949849	21439	8D00062-10	PLATE,INSTRUCTION.....	1
18	PAOZZ	9905013949856	21439	8D00062-9	PLATE,INSTRUCTION.....	1
19	PAOZZ	9905013954077	21439	8D00062-17	PLATE,INSTRUCTION.....	2
20	PAOZZ	9905013949851	21439	8D00062-14	PLATE,INSTRUCTION.....	1
21	PAOZZ	9905013949859	21439	8D00062-18	PLATE,INSTRUCTION REAR.....	1
21	PFOZZ	7690014318641	21439	8D00062-25	LABEL FRONT.....	1
22	PFOZZ	5305014171546	45722	NO. 4-5/16	SCREW,MACHINE #4 X 5/16.....	68
23	PAOZZ	5305014171545	45722	NO. 4-3/16	SCREW,MACHINE #4 X 3/16..... USE WITH PLATES 1 AND 16	12

END OF FIGURE

1	6
2 AND 3	7 THRU 9

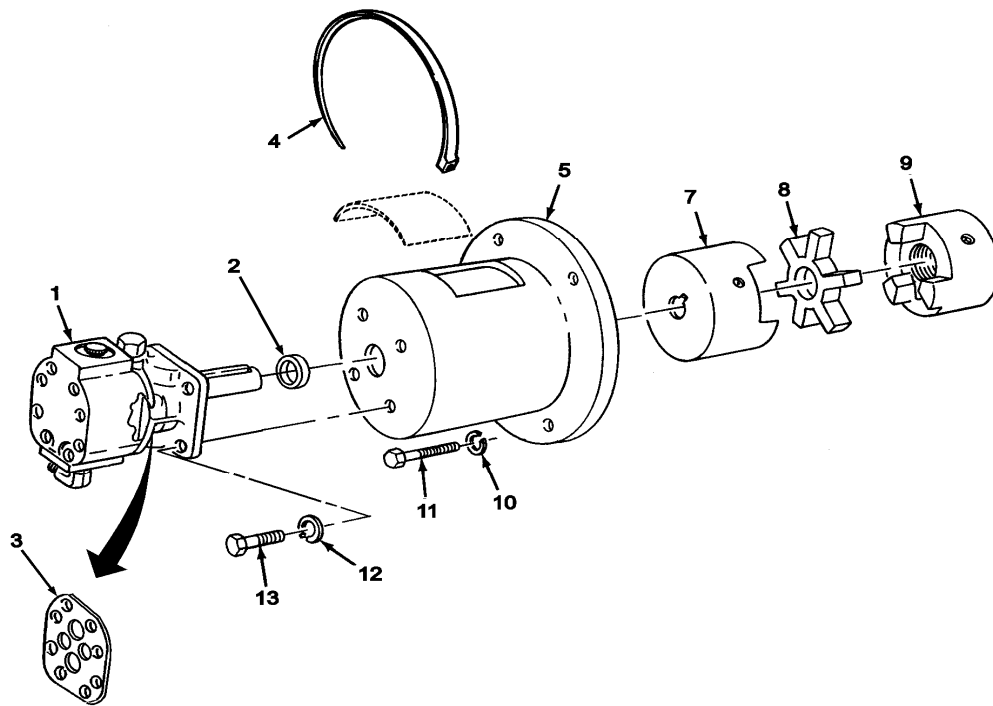


Figure 28. Hydraulic Pump and Adapter.



(1) ITEM NO	(2) SMR CODE	(3) NSN	(4) CAGEC	(5) PART NUMBER	(6) DESCRIPTION AND USABLE ON CODES (UOC)	(7) QTY
<b>GROUP 24 HYDRAULIC AND FLUID SYSTEM</b>						
<b>GROUP 2401 PUMP AND MOTOR</b>						
<b>FIG. 28 HYDRAULIC PUMP AND ADAPTER</b>						
1	PAOZZ	4320013939843	21439	8D00095-1	PUMP,ROTARY . . . . .	1
2	PAOZZ	5330005265783	80201	5062	.SEAL,PLAIN ENCASED . . . . .	1
3	XDOZZ		70763	2300622	.SEAL KIT . . . . .	1
4	PAOZZ		7Z588	QS200M80S	CLAMP,HOSE . . . . .	1
5	PAOZZ	3040013937533	21439	8D00096-1	ADAPTER,HOUSING . . . . .	1
6	PAOZZ	3010013932160	21439	8D00143-1	COUPLING,SHAFT,FLEX . . . . .	1
7	XAOZZ	3010005854215	75665	L095-3-4	.COUPLING,SHAFT,FLEX . . . . .	1
8	XAOZZ	2530014220248	75665	L-090/095	.SPIDER,BRAKE . . . . .	1
9	XAOZZ		75665	L-095-1/2	.COUPLING, HALF . . . . .	1
10	PAOZZ	5310006379541	81718	H2525M	WASHER,LOCK 3/8 . . . . .	4
11	PAOZZ	5305000680511	80204	B1821BHO38C125 N	SCREW,CAP,HEXAGON H 3/8-16 X 1 1/4 . . . . .	4
12	PAOZZ	5310004079566	96906	MS35338-45	WASHER,LOCK 5/16 . . . . .	4
13	PAOZZ	5306002264825	80204	B1821BH031C075 N	BOLT,MACHINE 5/16-18 X 3/4 . . . . .	4

END OF FIGURE

1	13
2 THRU 18	14

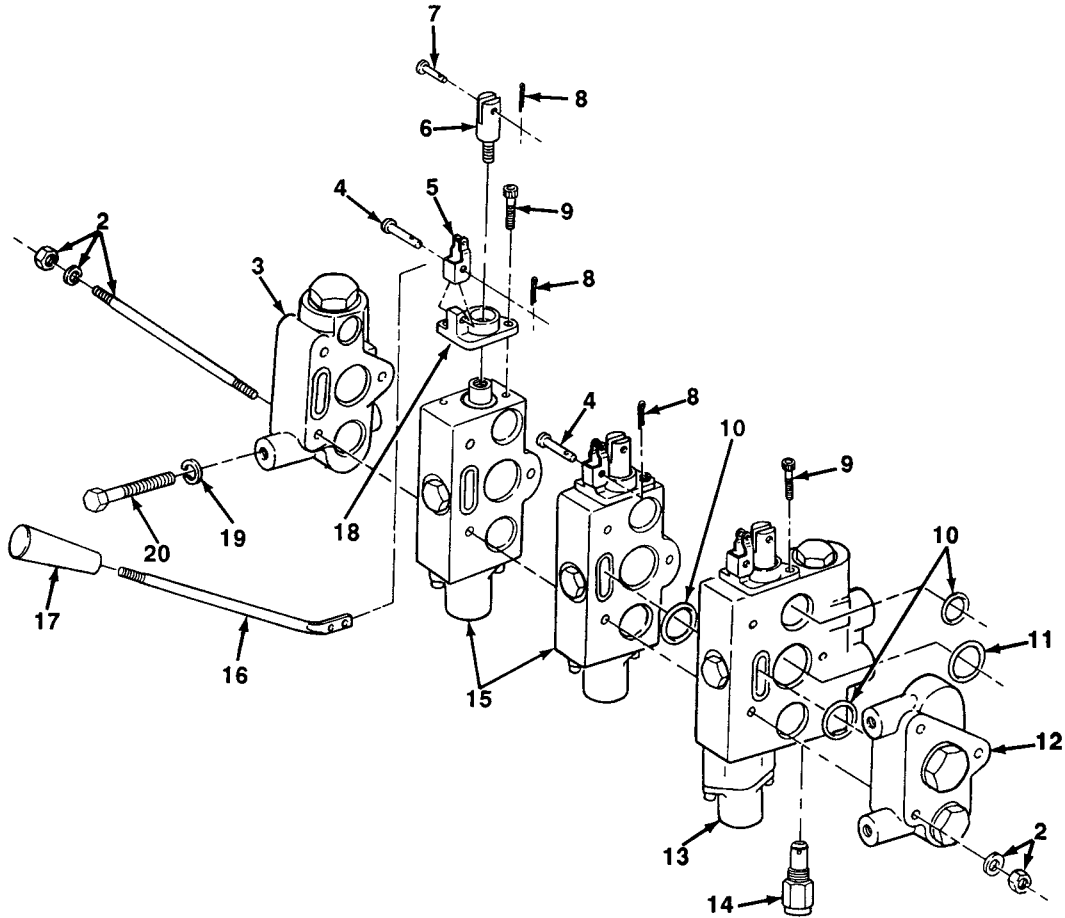


Figure 29. Control Valve.

(1) ITEM NO	(2) SMR CODE	(3) NSN	(4) CAGEC	(5) PART NUMBER	(6) DESCRIPTION AND USABLE ON CODES (UOC)	(7) QTY
<b>GROUP 2402 MANIFOLD AND/OR CONTROL VALVES</b>						
<b>FIG. 29 CONTROL VALVE</b>						
1	PAOFF	4820013935276	21439	8D00109-1	VALVE,LINER,DIRECT REAR CLT . . . . .	1
1	PAOFF	4820014312389	21439	8D00109-14	BODY SECTION,WORKIN FRONT CLT . . . . .	1
2	PFFZZ	2530013935878	29260	660401003	.PARTS KIT,STEERING . . . . .	3
3	PFFZZ	4820013935274	21439	8D00196-10	.VALVE,LINER,DIRECT . . . . .	1
4	KFFZZ		21439	8D00196-43	.PIN,CLEVIS. . . . . PART OF KIT P/N 8D00196-89	6
5	KFFZZ		21439	8D00196-40	.LINK . . . . . PART OF KIT P/N 8D00196-89	3
6	KFFZZ		21439	8D00196-34	.ADAPTER,SPOOL END . . . . . PART OF KIT P/N 8D00196-89	3
7	KFFZZ		21439	8D00196-42	.PIN,CLEVIS. . . . . PART OF KIT P/N 8D00196-89	3
8	KFFZZ		21439	8D00196-38	.PIN,COTTER . . . . . PART OF KIT P/N 8D00196-89	9
9	KFFZZ		21439	8D00196-36	.SCREW,CAP . . . . . PART OF KIT P/N 8D00196-89	6
10	KFFZZ		21439	8D00196-15	.PACKING,PREFORMED. . . . . PART OF KIT P/N 8D00196-86	12
11	KFFZZ		21439	8D00196-16	.PACKING,PREFORMED. . . . . PART OF KIT P/N 8D00196-86	4
12	PFFZZ	4820013940480	29260	SVE12	.VALVE,LINER,DIRECT . . . . .	1
13	PFFZZ	4820013940541	21439	8D00196-44	.VALVE,LINER,DIRECT . . . . .	1
14	PFFZZ	4820014197040	21439	8D00196-72	..VALVE,SAFETY RELIEF . . . . .	1
15	PFFZZ	4820013936363	29260	SVW1BA1	.BODY SECTION,WORKING . . . . .	2
16	PFFZZ	5340014322903	21439	8D00196-94	.HANDLE,BAIL FRONT CLT . . . . .	3
16	KFFZZ		21439	8D00196-37	.HANDLE . . . . . PART OF KIT P/N 8D00196-89	3
17	KFFZZ		21439	8D00196-39	.KNOB,HANDLE. . . . . PART OF KIT P/N 8D00196 89	3
18	KFFZZ		21439	8D00196-41	.CLEVIS . . . . . PART OF KIT P/N 8D00196-89	3
19	PAOZZ	5310006379541	81718	H2525M	WASHER,LOCK 3/8 . . . . .	3
20	PAOZZ	5305001159526	80204	B1821BH038C075 D	SCREW,CAP,HEXAGON H 3/8-16 X 3/4. . . . .	3

END OF FIGURE



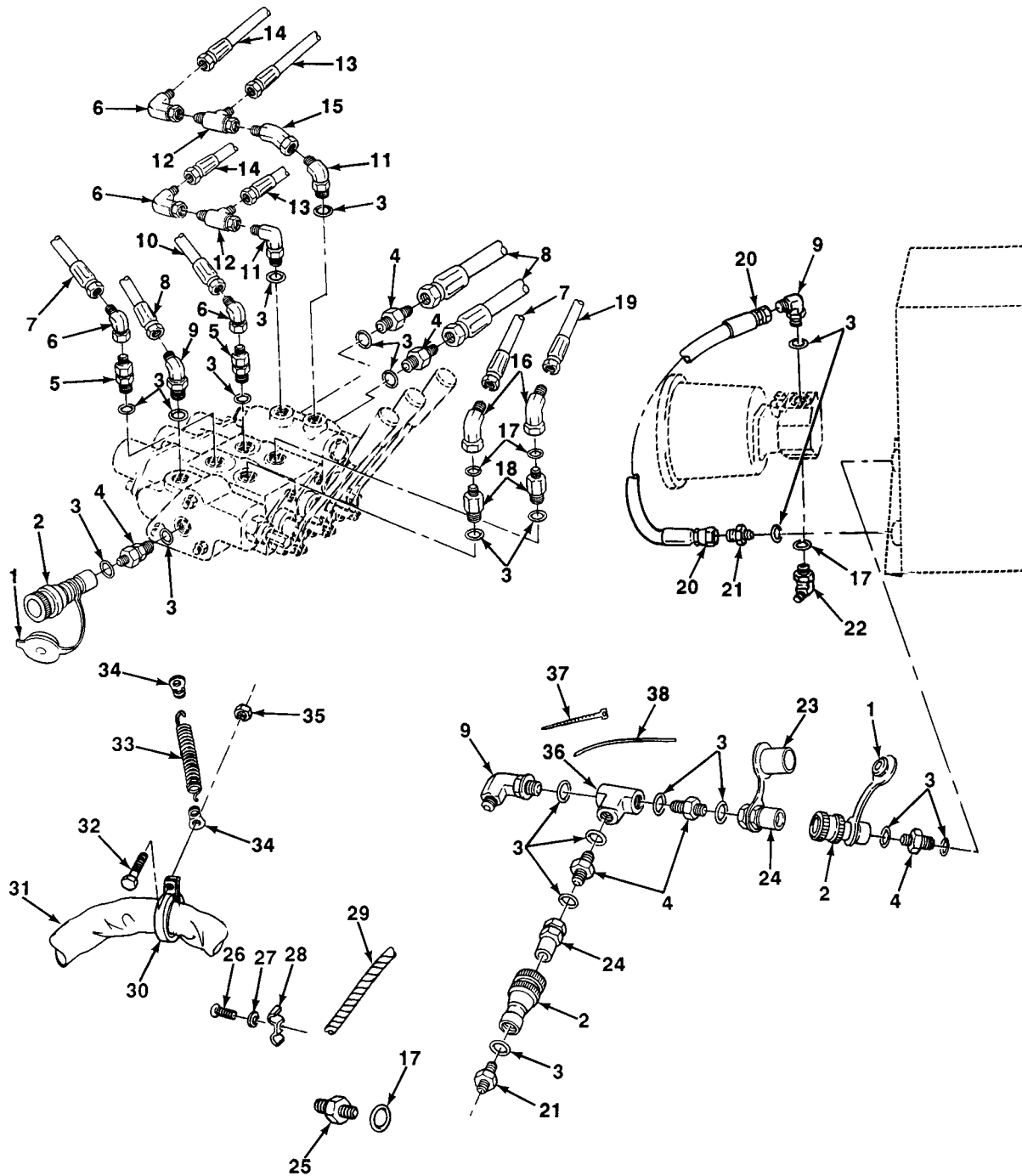


Figure 30. Hydraulic Lines and Fittings, Front (Sheet 1 of 2).

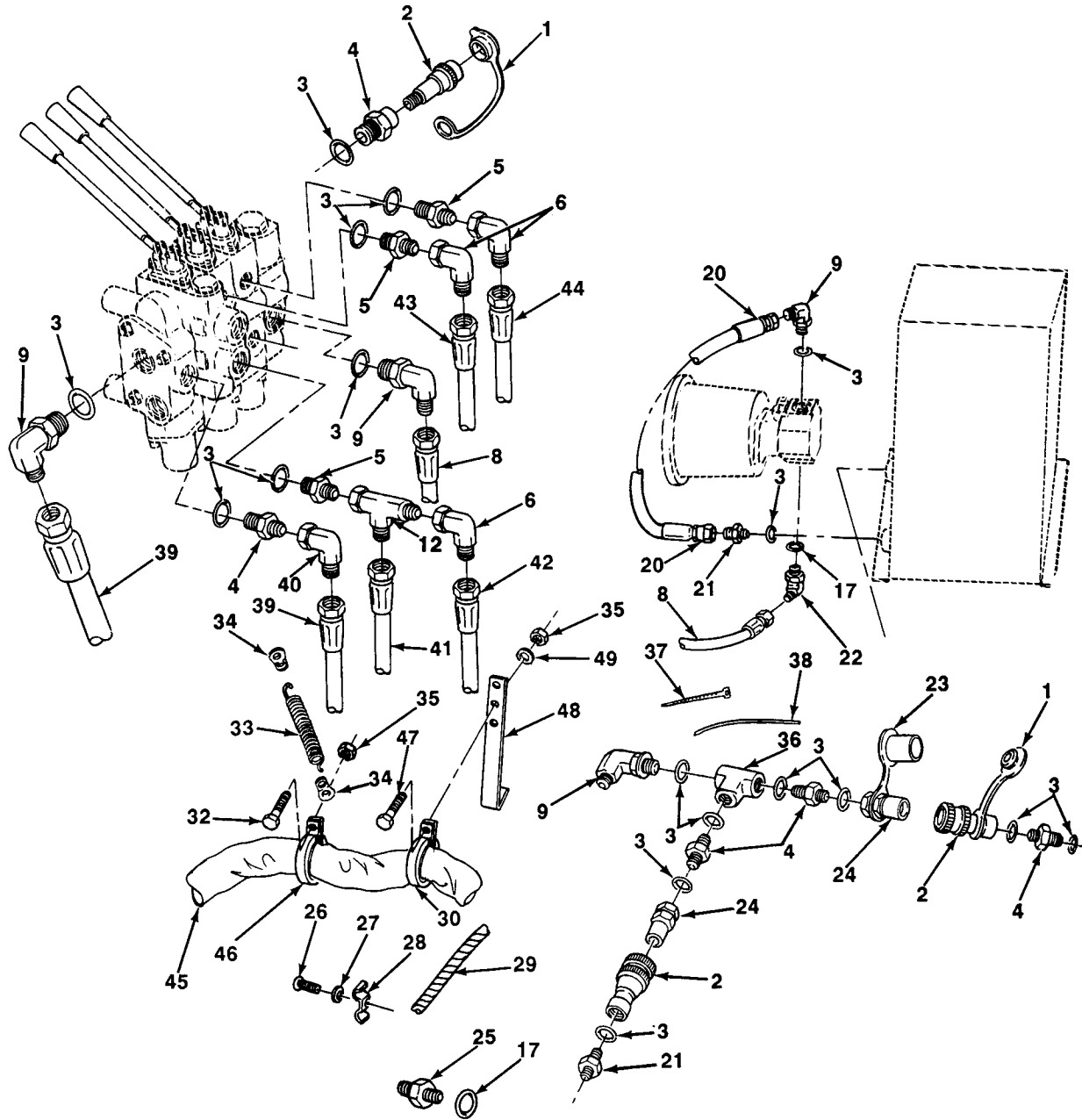


Figure 30. Hydraulic Lines and Fittings, Rear (Sheet 2 of 2).

(1) ITEM NO	(2) SMR CODE	(3) NSN	(4) CAGEC	(5) PART NUMBER	(6) DESCRIPTION AND USABLE ON CODES (UOC) GROUP 2406 STRAINERS, FILTERS, LINES, AND FITTINGS, ETC.  FIG. 30 HYDRAULIC LINES AND FITTING	(7) QTY
1	PAOZZ	5340013565057	97111	H3-65M	CAP,PROTECTIVE,DUST .....	2
2	PAOZZ		30780	H3-62-T8-659	FITTING,QUICK DIS. ....	3
3	PCOZZ	5331008080794	96906	MS28778-8	O-RING.....	21
4	PAOZZ	4730009037652	30780	8LHTX-S	NIPPLE,TUBE FRONT .....	6
4	PAOZZ	4730009037652	30780	8LHTX-S	NIPPLE,TUBE REAR.....	5
5	PAOZZ		90661	6-8F5XS	ADAPTER,STRAIGHT FRONT.....	2
5	PAOZZ		90661	6-8F5XS	ADAPTER,STRAIGHT REAR.....	6
6	PAOZZ	4730006185372	81343	6-6 070221CA	ELBOW,TUBE FRONT .....	4
6	PAOZZ	4730006185372	81343	6-6 070221CA	ELBOW,TUBE REAR.....	6
7	PCOZZ	4720013934575	98441	451AR-05-06-6-6-4-40	HOSE ASSEMBLY,NONME FRONT.....	2
8	PCOZZ	4720013934572	21439	8D00052-2	HOSE ASSEMBLY,NONME FRONT.....	3
8	PCOZZ	4720013934572	21439	8D00052-2	HOSE ASSEMBLY,NONME REAR.....	1
9	PAOZZ	4730008225609	96906	MS51527A8	ELBOW,TUBE TO BOSS FRONT.....	3
9	PAOZZ	4730008225609	96906	MS51527A8	ELBOW,TUBE TO BOSS REAR.....	4
10	PCOZZ	4720013934577	98441	451AR-05-06-6-6-4-92	HOSE ASSEMBLY,NONME FRONT.....	2
11	PFOZZ		90661	6-8C5XS	ELBOW.....	2
12	PAOZZ	4730006185381	30780	6R6BXS	TEE,TUBE .....	2
13	PCOZZ	4720013934576	98441	451AR-39-06-6-6-4-78	HOSE ASSEMBLY,NONME FRONT.....	2
14	PCOZZ	4720013935278	98441	451AR-3-06-6-6-4-129	HOSE ASSEMBLY,NONME FRONT.....	2
15	PAOZZ	4730011957331	01276	2070-6-6S	ELBOW,TUBE.....	1
16	PFOZZ		30780	6CC5XS	ELBOW,PIPE TO TUBE.....	2
17	PCOZZ	5331008045695	96906	MS28778-6	O-RING FRONT.....	7
17	PCOZZ	5331008045695	96906	MS28778-6	O-RING REAR.....	5
18	PAOZZ	4730009330727	30780	8-6-F5G5-S	REDUCER,BOSS.....	2
19	PCOZZ	4720013935277	98441	451AR-05-06-6-6-4-96	HOSE ASSEMBLY,NONME FRONT.....	1
20	PFOZZ	4720014197872	21439	8D00052-3	HOSE ASSEMBLY,NONME .....	1
21	PAOZZ	4730011564835	30780	8F5BX-S	ADAPTER,STRAIGHT,TU .....	2
22	PAOZZ	4730002250699	97403	13211E9018-12	ELBOW,TUBE TO BOSS.....	1
23	PAOZZ	5340013074395	97403	13229E0887-2	PLUG,PROTECTIVE,DUS.....	1
24	PAOZZ		30780	H3-63-T8-659	COUPLING HALF,QUICK.....	2
25	PAOZZ	4730013345710	30327	848-FS-06X06	ADAPTER,STRAIGHT,TU .....	4
26	PAOZZ	5305000526921	80205	MS24629-57	SCREW,TAPPING 1/4 X 1/2 .....	3

(1) ITEM NO	(2) SMR CODE	(3) NSN	(4) CAGEC	(5) PART NUMBER	(6) DESCRIPTION AND USABLE ON CODES (UOC) GROUP 2406 STRAINERS, FILTERS, LINES, AND FITTINGS, ETC. FIG. 30 HYDRAULIC LINES AND FITTING - CONT	(7) QTY
27	PAOZZ	5310001411795	88044	AN960-416	WASHER,FLAT 1/4 . . . . .	3
28	PAOZZ	5340014177278	93061	3121-4-10	CLAMP,LOOP. . . . .	3
29	PFOZZ		21439	8D00065-13	SLEEVE,COIL FRONT . . . . .	2
29	PFOZZ		21439	8D00065-13	SLEEVE,COIL REAR. . . . .	4
30	PAOZZ	5340005316857	96906	MS21919WDG40	CLAMP,LOOP. . . . .	1
31	PFOZZ		21439	8D00358-1	SLEEVE,ABRASION . . . . .	1
32	PAOZZ	5305000593660	96906	MS51958-64	SCREW,MACHINE. . . . .	1
33	PFOZZ		56988	192	SPRING,EXTENSION . . . . .	1
34	PFOZZ		84256	C8	TAB,LANYARD . . . . .	2
35	PAOZZ	5310002089255	96906	MS21044C330-1	NUT,SELF-LOCKING,HE FRONT . . . . .	1
35	PAOZZ	5310002089255	96906	MS21044C3	NUT,SELF-LOCKING,HE REAR . . . . .	2
36	PAOZZ	4730002775056	88044	AN938-8	TEE,BOSS . . . . .	1
37	PAOZZ	5975009856630	96906	MS3367-3-0	STRAP,TIEDOWN,ELECT FRONT . . . . .	5
37	PAOZZ	5975009856630	96906	MS3367-3-0	STRAP,TIEDOWN,ELECT REAR . . . . .	6
38	MOOZZ		96906	MS20995C20-12IN	WIRE,NONELECTRICAL . . . . . MAKE FROM P/N MS20995C20	1
39	PCOZZ	4720014185287	21439	8D00052-1	HOSE ASSEMBLY,NONME REAR . . . . .	1
40	XDOZZ		30780	8C6XS	ELBOW,TUBE REAR. . . . .	1
41	PCOZZ	4720013934581	21439	8D00052-11	HOSE ASSEMBLY,NONME REAR . . . . .	2
42	PCOZZ	4720013935880	21439	8D00052-12	HOSE ASSEMBLY,NONME REAR . . . . .	2
43	PCOZZ	4720013935886	21439	8D00052-9	HOSE ASSEMBLY,NONME REAR . . . . .	2
44	PCOZZ	4720013935884	21439	8D00052-8	HOSE ASSEMBLY,NONME REAR . . . . .	2
45	PFOZZ		21439	8D00358-1	SLEEVE,ABRASION . . . . .	1
46	PAOZZ	5340002003045	96906	MS21919WDG24	CLAMP,LOOP. . . . .	1
47	PAOZZ	5305000593661	96906	MS51958-65	SCREW,MACHINE. . . . .	1
48	PFOZZ		21439	8D00359-1	BRACKET,ANGLE . . . . .	1
49	PAOZZ	5310006151556	28527	2616950G001	WASHER,FLAT. . . . .	1

END OF FIGURE





1  
2 THRU 15

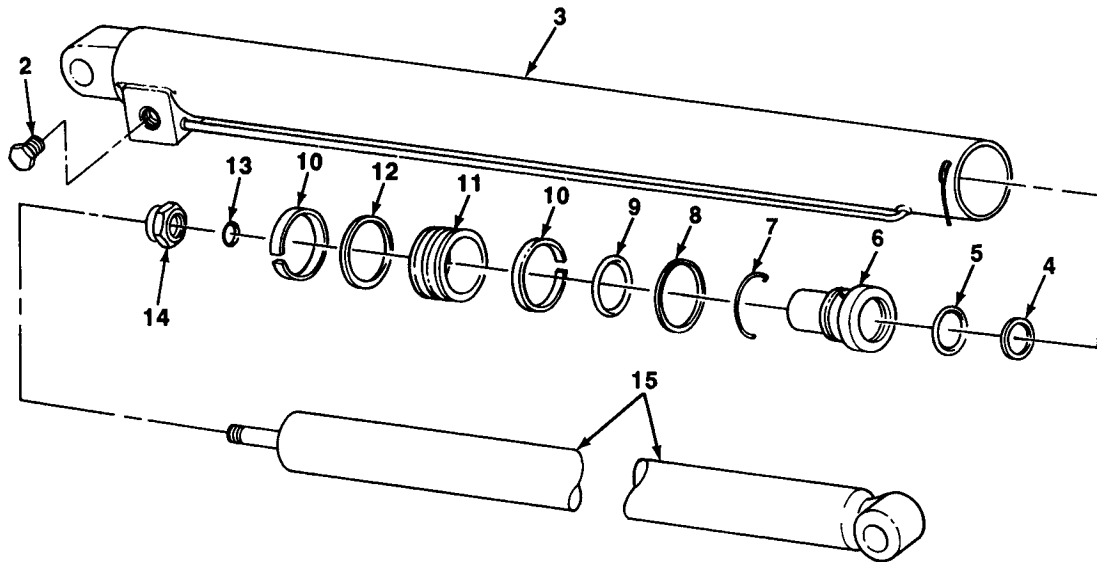


Figure 31. Lift Cylinder.

(1) ITEM NO	(2) SMR CODE	(3) NSN	(4) CAGEC	(5) PART NUMBER	(6) DESCRIPTION AND USABLE ON CODES (UOC) GROUP 2407 HYDRAULIC CYLINDERS FIG. 31 LIFT CYLINDER	(7) QTY
1	PBOFF	3040013937529	21439	8D00145-1	CYLINDER ASSEMBLY,A . . . . .	2
2	PFOZZ	4820014180937	21439	POCI-10-N-O-XX	.VALVE,CHECK . . . . .	1
3	XAFZZ		21439	8D00051-10	.BARREL ASSY . . . . .	1
4	KFFZZ		21439	8D00051-15	.WIPER,ROD . . . . . PART OF KIT P/N 8D00051-17	1
5	KFOZZ		21439	8D00051-16	.SEAL,ROD . . . . . PART OF KIT P/N 8D00051-17	1
6	XAFZZ		21439	8D00051-13	.HEAD . . . . .	1
7	PFFZZ		21439	8D00051-14	.LOCKWIRE . . . . .	1
8	KFFZZ		21439	8D00051-12	.SEAL,BACKUP . . . . . PART OF KIT P/N 8D00051-17	1
9	KFFZZ		21439	8D00051-8	.PACKING,PREFORMED . . . . . PART OF KIT P/N 8D00061-17	1
10	KFFZZ		21439	8D00051-5	.RING,WEAR . . . . . PART OF KIT P/N 8D00051-17	1
11	PFFZZ	3040014660005	21439	8D00051-7	.PISTON,LINEAR ACTUA . . . . .	1
12	KFFZZ		21439	8D00051-6	.SEAL,PISTON . . . . . PART OF KIT P/N 8D00051-17	1
13	KFFZZ		21439	8D00051-11	.PACKING,PREFORMED . . . . . PART OF KIT P/N 8D00051-17	1
14	PFFZZ		21439	8D00051-4	.NUT,SELF-LOCKING,HE . . . . .	1
15	XAFZZ		21439	8D00051-9	.ROD ASSY . . . . .	1

END OF FIGURE

1  
2 THRU 16

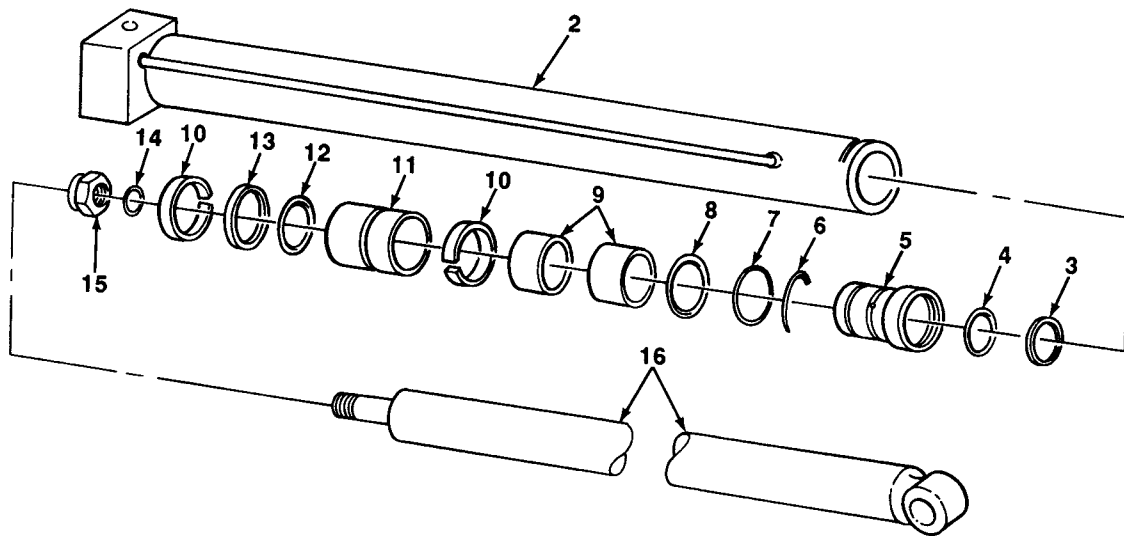


Figure 32. Positioning Cylinder.

(1) ITEM NO	(2) SMR CODE	(3) NSN	(4) CAGEC	(5) PART NUMBER	(6) DESCRIPTION AND USABLE ON CODES (UOC)	(7) QTY
<b>GROUP 2407 HYDRAULIC CYLINDERS</b>						
<b>FIG. 32 POSITIONING CYLINDER</b>						
1	PBOFF	3040013937983	21439	8D00146-1	CYLINDER ASSEMBLY,A . . . . .	1
2	XAFZZ		21439	8D00152-12	.BARREL ASSY . . . . .	1
3	KFFZZ		21439	8D00152-17	.WIPER,ROD . . . . . PART OF KIT P/N 8D00152-21	1
4	KFFZZ		21439	8D00152-18	.SEAL,ROD . . . . . PART OF KIT P/N 8D00152-21	1
5	XAFZZ		21439	8D00152-16	.HEAD . . . . .	1
6	PFFZZ	5365014669524	21439	8D00152-15	.ANCHOR PLATE ASSEMBLY . . . . .	1
7	KFFZZ		21439	8D00152-13	.PACKING,PREFORMED . . . . . PART OF KIT P/N 8D00152-21	1
8	KFFZZ		21439	8D00152-20	.SEAL,BACKUP . . . . . PART OF KIT P/N 8D00152-21	1
9	PFFZZ		21439	8D00152-23	.TUBE,METALLIC . . . . .	2
10	KFFZZ		21439	8D00152-22	.RING,WEAR . . . . . PART OF KIT P/N 8D00152-21	2
11	PFFZZ	3040014660004	21439	8D00152-8	.PISTON,LINEAR ACTUA . . . . .	1
12	KFFZZ		21439	8D00152-19	.PACKING,PREFORMED . . . . . PART OF KIT P/N 8D00152-21	1
13	KFFZZ		21439	8D00152-7	.PACKING,PREFORMED . . . . . PART OF KIT P/N 8D00152-21	1
14	KFFZZ		21439	8D00152-6	.SEAL,PISTON . . . . . PART OF KIT P/N 8D00152-21	1
15	PFFZZ		21439	8D000152-4	.NUT,PLAIN,HEXAGON . . . . .	1
16	XAFZZ		21439	8D00152-11	.ROD ASSY . . . . .	1

END OF FIGURE

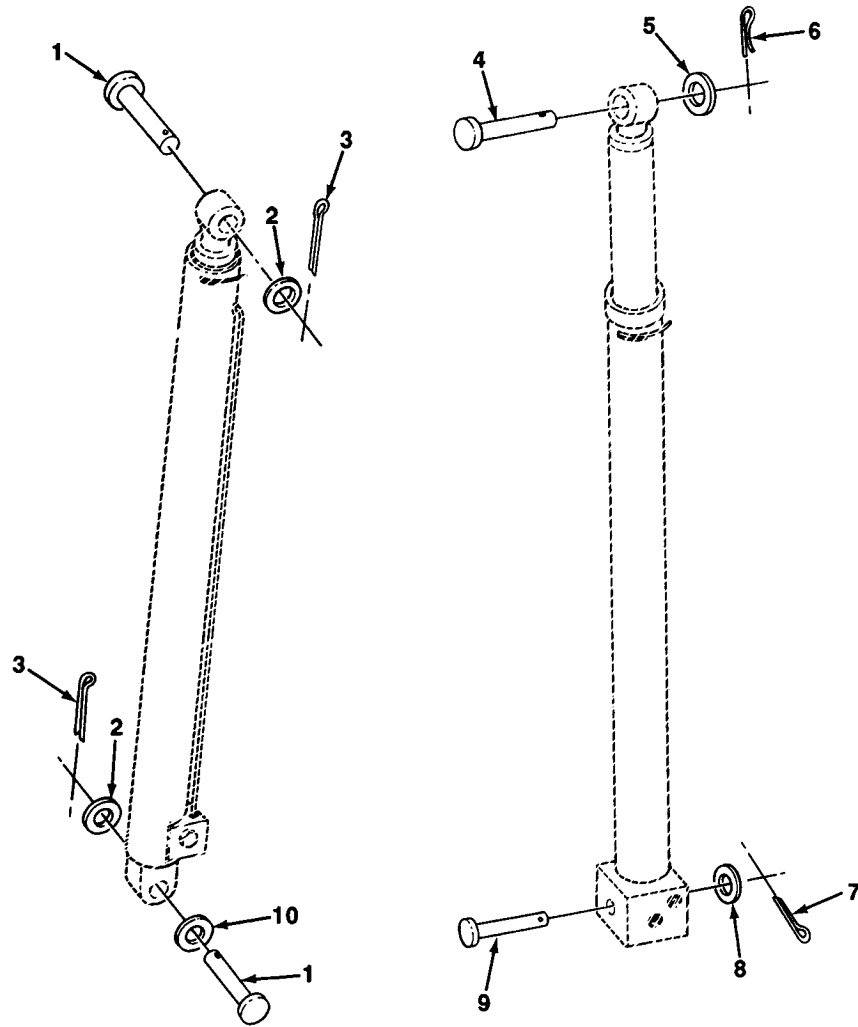


Figure 33. Hydraulic Cylinder Mounting.

(1) ITEM NO	(2) SMR CODE	(3) NSN	(4) CAGEC	(5) PART NUMBER	(6) DESCRIPTION AND USABLE ON CODES (UOC)	(7) QTY
<b>GROUP 2407 HYDRAULIC CYLINDERS</b>						
<b>FIG. 33 HYDRAULIC CYLINDER MOUNTING</b>						
1	PAOZZ	5315013929397	21439	8D00060-1	PIN,STRAIGHT,HEADED.....	2
2	PAOZZ	5310006161124	88044	AN960-2016L	WASHER,FLAT 1 1/4.....	2
3	PAOZZ	5315000590217	96906	MS24665-624	PIN,COTTER .....	2
4	PAOZZ	5315013929394	21439	8D00060-2	PIN,STRAIGHT,HEADED.....	1
5	PAOZZ	5310001670828	88044	AN960-1616	WASHER,FLAT 1 IN .....	1
6	PAOZZ	5315002341664	96906	MS24665-495	PIN,COTTER .....	1
7	PAOZZ	5315008395821	96906	MS24665-351	PIN,COTTER .....	1
8	PAOZZ	5310012671685	96906	MS51412-8	WASHER,FLAT 1/2 .....	1
9	PAOZZ	5315013929391	21439	8D00060-3	PIN,STRAIGHT,HEADED.....	1
10	PFOZZ	5365014169992	21439	8D00226-1	SPACER,RING L.H. FRONT.....	1
10	PFOZZ	5365014169992	21439	8D00226-1	SPACER,RING REAR.....	2

END OF FIGURE

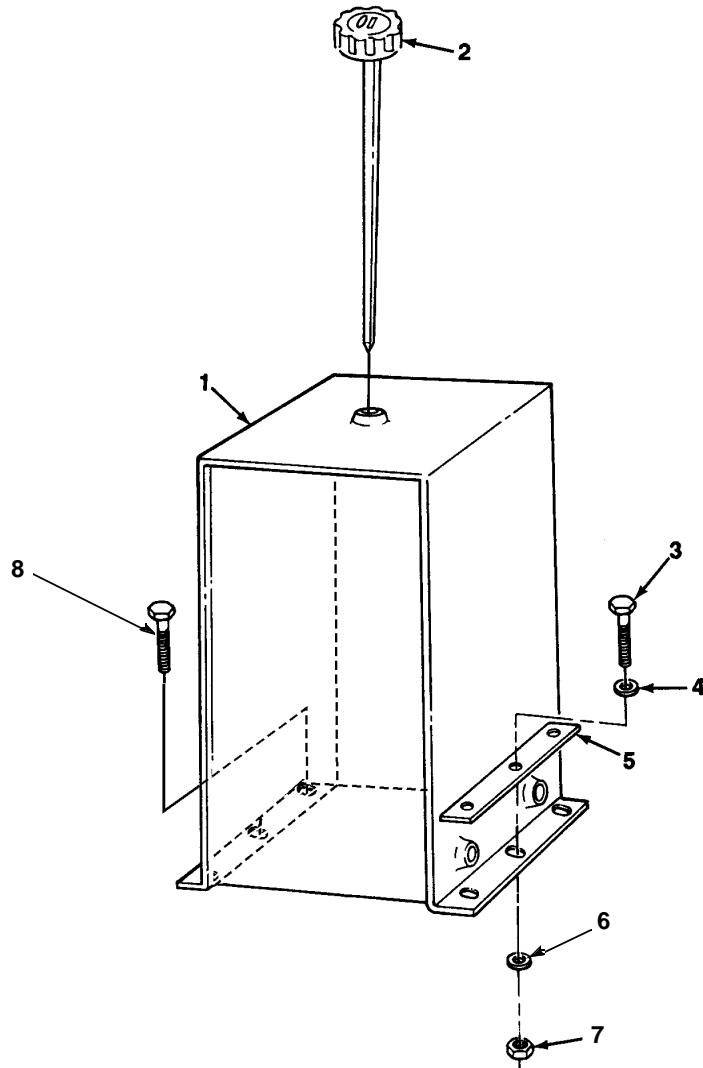


Figure 34. Hydraulic Reservoir.



(1) ITEM NO	(2) SMR CODE	(3) NSN	(4) CAGEC	(5) PART NUMBER	(6) DESCRIPTION AND USABLE ON CODES (UOC)	(7) QTY
<b>GROUP 2408 LIQUID TANKS OR RESERVOIR</b>						
<b>FIG. 34 HYDRAULIC RESERVOIR</b>						
1	PFOZZ	4320013939844	21439	8D00115-1	RESERVOIR, HYDRAULIC. ....	1
2	PAOZZ	6680013934023	59838	PBS-10-5-D10	GAGE ROD-BREATHER, L. ....	1
3	PAOZZ	5306002264825	80204	B1821BH031C075 N	BOLT, MACHINE 5/16-18 X 3/4 QTY 5. FOR REAR TRAY	6
4	PAOZZ		58051	AN960-516	WASHER, FLAT 5/16. ....	6
5	PFOZZ	5340014219482	21439	8D00281-1	PLATE, MOUNTING . ....	2
6	PAOZZ	5310000446477	96906	MS51412-25	WASHER, FLAT 5/16. ....	6
7	PAOZZ	5310009843806	81349	M45913/1-5CG5C	NUT, SELF-LOCKING, HE 5/16-18 . ....	6
8	PAOZZ	5306002258499	96906	MS90725-34	BOLT, MACHINE 5/16-18 X 1 . .... REAR TRAY ONLY	1

END OF FIGURE

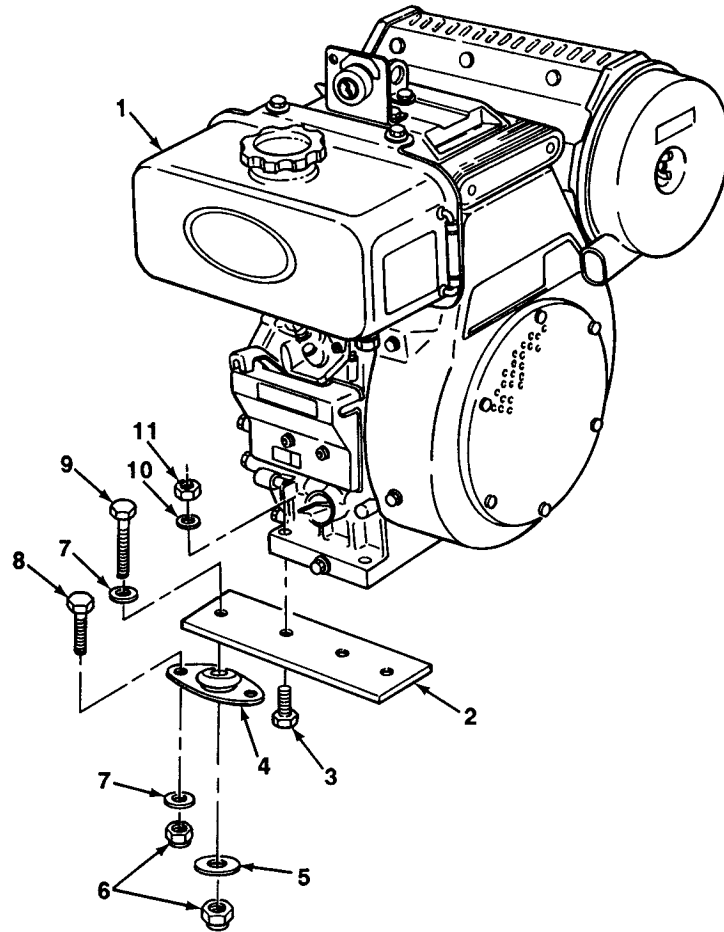


Figure 35. Engine Assembly.

(1) ITEM NO	(2) SMR CODE	(3) NSN	(4) CAGEC	(5) PART NUMBER	(6) DESCRIPTION AND USABLE ON CODES (UOC)	(7) QTY
<b>GROUP 29 AUXILIARY GENERATOR AND ENGINE, AND CONTROLS</b>						
<b>GROUP 2910 ENGINE ASSEMBLY</b>						
<b>FIG. 35 ENGINE ASSEMBLY</b>						
1	PAOZZ	2815013939846	31013	OC60E1	ENGINE,DIESEL .....	1
2	PFOZZ	5340013931860	21439	8D00133-1	PLATE,MOUNTING .....	2
3	PAOZZ	5305008213869	80204	B1821BH038C175 N	SCREW,CAP,HEXAGON H 3/8-16 X 1 3/4 .....	4
4	PFOZZ	5342013932877	81860	505-1LS	MOUNT,RESILIENT .....	4
5	PFOZZ	5310013936783	81860	R18733-6	WASHER,SHOULDERED .....	4
6	PAOZZ	5310009843806	81349	M45913/1-5CG5C	NUT,SELF-LOCKING,HE 5/16-18 .....	12
7	PAOZZ	5310000446477	96906	MS51412-25	WASHER,FLAT 7/16 .....	12
8	PAOZZ	5306002264825	80204	B1821BH031C075 N	BOLT,MACHINE 5/16-18 X 3/4 .....	8
9	PAOZZ	5306002264834	80204	B1821BH031C225 N	BOLT,MACHINE 5/16-18 X 2 1/4 .....	4
10	PAOZZ	5310001670821	88044	AN960-616	WASHER,FLAT 3/8 .....	4
11	PAOZZ	5310000874652	96906	MS51922-17	NUT,SELF-LOCKING,HE 3/8-16 .....	4
END OF FIGURE						

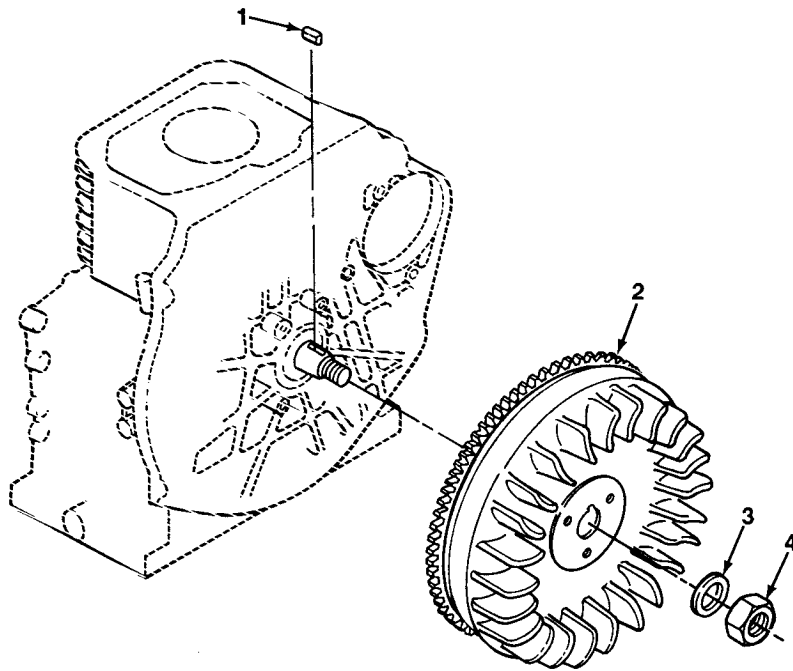


Figure 36. Flywheel and Ring Gear.

(1) ITEM NO	(2) SMR CODE	(3) NSN	(4) CAGEC	(5) PART NUMBER	(6) DESCRIPTION AND USABLE ON CODES (UOC)	(7) QTY
<b>GROUP 2913 FLYWHEEL ASSEMBLY</b>						
<b>FIG. 36 FLYWHEEL AND RING GEAR</b>						
1	PAOZZ	5315013931316	31013	05712-00520	KEY,MACHINE . . . . .	1
2	PAOZZ	2815013937541	31013	11420-6703-0	FLYWHEEL,ENGINE . . . . .	1
3	PAOZZ	5310013936782	31013	11420-2337-0	WASHER,FLAT. . . . .	1
4	PAOZZ	5310013936785	31013	15261-2336-0	NUT,PLAIN,HEXAGON. . . . .	1

END OF FIGURE

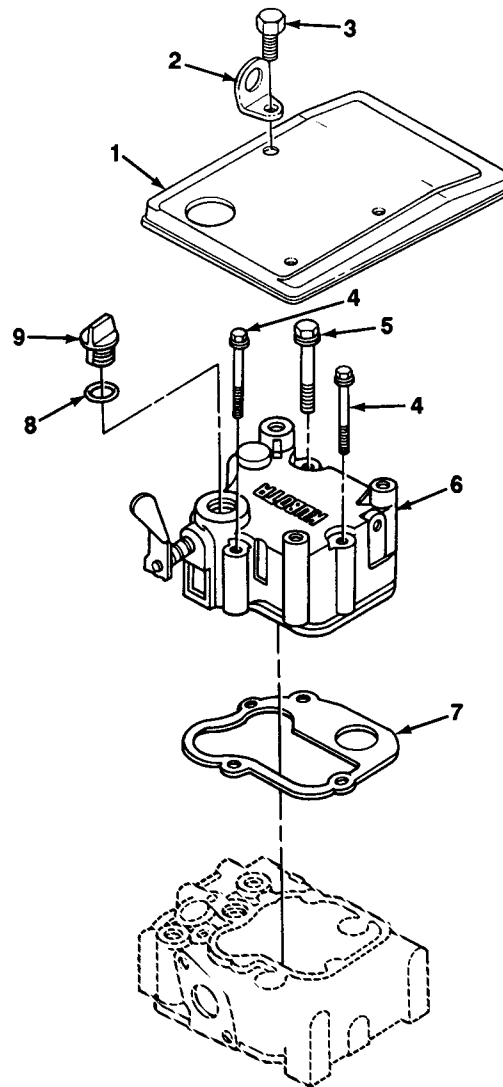


Figure 37. Rocker Arm Cover.

(1) ITEM NO	(2) SMR CODE	(3) NSN	(4) CAGEC	(5) PART NUMBER	(6) DESCRIPTION AND USABLE ON CODES (UOC) GROUP 2915 VALVES, CAMSHAFTS, AND TIMING SYSTEM  FIG. 37 ROCKER ARM COVER	(7) QTY
1	PFOZZ	5340014204519	31013	11811-3703-0	COVER,ACCESS.....	1
2	PFOZZ	1730014196112	31013	11811-0175-0	HOOK ASSEMBLY,ENGINE.....	1
3	PAOZZ	5305013934859	31013	01754-50825	SCREW,CAP,HEXAGON H.....	1
4	PFOZZ	5306013934862	31013	01754-50650	BOLT,MACHINE.....	2
5	PFOZZ	5306013934864	31013	01754-50855	BOLT,MACHINE.....	1
6	PFOZZ	5340013932876	31013	11520-1450-0	COVER,ACCESS.....	1
7	PCOZZ	5330013933744	31013	11420-1452-0	GASKET.....	1
8	PCOZZ	5331013932861	31013	04811-00180	O-RING.....	1
9	PAOZZ	5342013932869	31013	11420-3308-2	CAP,FILLER OPENING.....	1

END OF FIGURE

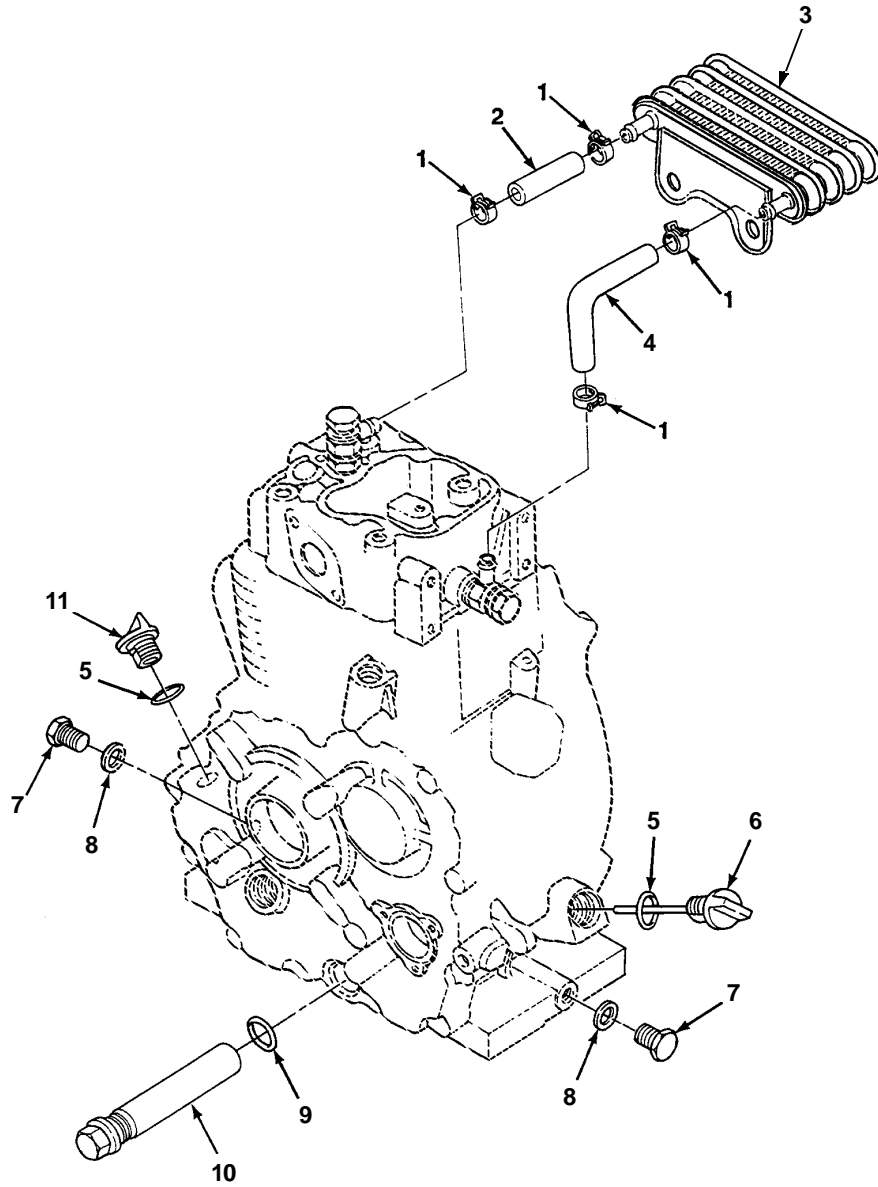


Figure 38. Oil Filter, Lines, and Plugs.



(1) ITEM NO	(2) SMR CODE	(3) NSN	(4) CAGEC	(5) PART NUMBER	(6) DESCRIPTION AND USABLE ON CODES (UOC) GROUP 2916 ENGINE LUBRICATION SYSTE FIG. 38 OIL FILTER, LINES, AND PLUGS	(7) QTY
1	PAOZZ	4730013932164	31013	14941-0557-0	CLAMP,HOSE.....	4
2	PCOZZ	4710013935241	31013	11420-3715-0	TUBE,METALLIC.....	1
3	XDOZZ		31013	11420-3701-0	COOLER,LUBRICATING.....	2
4	PCOZZ	4710013935245	31013	11420-3717-0	TUBE,BENT,METALLIC.....	1
5	PCOZZ	5331013932861	31013	04811-00180	O-RING.....	2
6	PAOZZ	6680013934020	31013	11420-3640-2	GAGE ROD-CAP,LIQUID.....	1
7	PAOZZ	5365013931859	31013	13901-3375-0	PLUG,MACHINE THREAD.....	2
8	PCOZZ	5331013935639	31013	04724-00120	O-RING.....	2
9	PCOZZ	5331013209556	S4532	04811-40140	O-RING.....	1
10	PAOZZ	2910013937530	31013	14911-3201-0	FILTER ELEMENT,FLUID.....	1
11	PAOZZ	5342013936306	31013	11521-3308-0	CAP,FILLER OPENING.....	1

END OF FIGURE



(1) ITEM NO	(2) SMR CODE	(3) NSN	(4) CAGEC	(5) PART NUMBER	(6) DESCRIPTION AND USABLE ON CODES (UOC)	(7) QTY
<b>GROUP 2932 ENGINE FUEL PUMP</b>						
<b>FIG. 39 FUEL INJECTION PUMP, NOZZLE, AND LINES</b>						
1	PAOZZ	4820013950406	31013	1G141-53000	NOZZLE, VALVE . . . . .	1
2	PAOZZ	4730013594773	31013	10244-4232-0	CLAMP, HOSE . . . . .	2
3	PCOZZ	4710013935244	31013	11420-4250-0	TUBE, METALLIC . . . . .	1
4	PAOZZ	5340013936307	31013	32240-3449-0	CLAMP, LOOP . . . . .	1
5	PAOZZ	5310013936781	31013	02156-50080	NUT, PLAIN, HEXAGON . . . . .	2
6	PAOZZ	5340013932859	31013	11420-5345-0	PLATE, MOUNTING . . . . .	1
7	PAOZZ	5307013934854	31013	01513-50855	STUD, PLAIN . . . . .	2
8	PAOZZ	5306013937080	31013	01754-50620	BOLT, MACHINE . . . . .	2
9	PAOZZ	4730013932162	31013	15471-9569-0	CONNECTOR, MULTIPLE . . . . .	1
10	PAOZZ	2910014166523	31013	1G131-51010	PUMP, FUEL, METERING . . . . .	1
11	PCOZZ	5365013931857	31013	1G131-52110	SHIM . . . . .	5
12	PAOZZ	5306013934847	31013	01754-60816	BOLT, MACHINE . . . . .	1
13	PAOZZ	5340013936308	31013	11420-5385-0	CLAMP, LOOP . . . . .	1
14	PAOZZ	4710013935872	31013	11420-5371-0	TUBE ASSEMBLY, METAL . . . . .	1
15	PCOZZ	5331014313621	31013	15841-53620	O-RING . . . . . FOR MODEL 0C60E1 ONLY	1
15	PCOZZ	5331013932862	31013	11420-5362-0	O-RING . . . . . FOR MODEL 0C60D1 ONLY	1
16	PCOZZ	5330014313620	31013	19077-53650	SEAL, PLAIN ENCASED . . . . . USE WITH P/N 1G141-53000	1

END OF FIGURE

1  
| 2 THRU 8 |

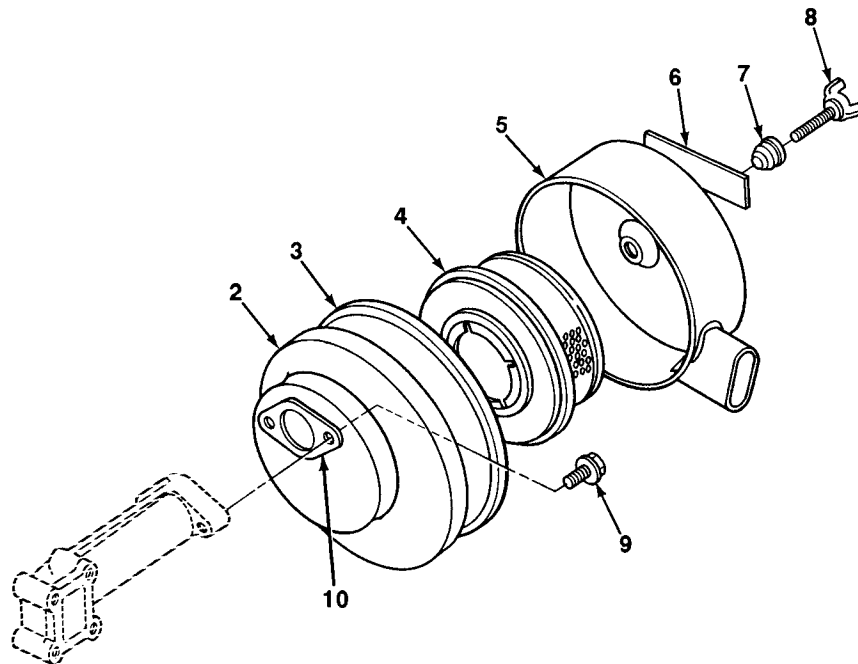


Figure 40. Air Cleaner Assembly.

(1) ITEM NO	(2) SMR CODE	(3) NSN	(4) CAGEC	(5) PART NUMBER	(6) DESCRIPTION AND USABLE ON CODES (UOC) GROUP 2933 ENGINE AIR CLEANER FIG. 40 AIR CLEANER ASSEMBLY	(7) QTY
1	PFOOO	2940013937532	31013	11420-1101-0	AIR CLEANER,INTAKE .....	1
2	XAOZZ		31013	11420-1115-0	.BODY,AIR CLEANER .....	1
3	PCOZZ	5331013932874	31013	12752-1117-0	.O-RING .....	1
4	PAOZZ	2940013935248	31013	11420-1118-0	.FILTER ELEMENT,INTA .....	1
5	XAOZZ		31013	11420-1116-0	.COVER,AIR CLEANER. ....	1
6	PAOZZ		31013	11420-8745-0	.PLATE, INSTRUCTION. ....	1
7	PAOZZ	5310013936779	31013	14351-1134-0	.WASHER,SEAL. ....	1
8	PAOZZ	5305013934856	31013	12752-1133-0	.THUMBSCREW. ....	1
9	PAOZZ	5306013934847	31013	01754-60816	BOLT,MACHINE .....	2
10	PCOZZ	5330013935638	31013	13965-1151-0	GASKET .....	1

END OF FIGURE

10  
|  
11 THRU 17

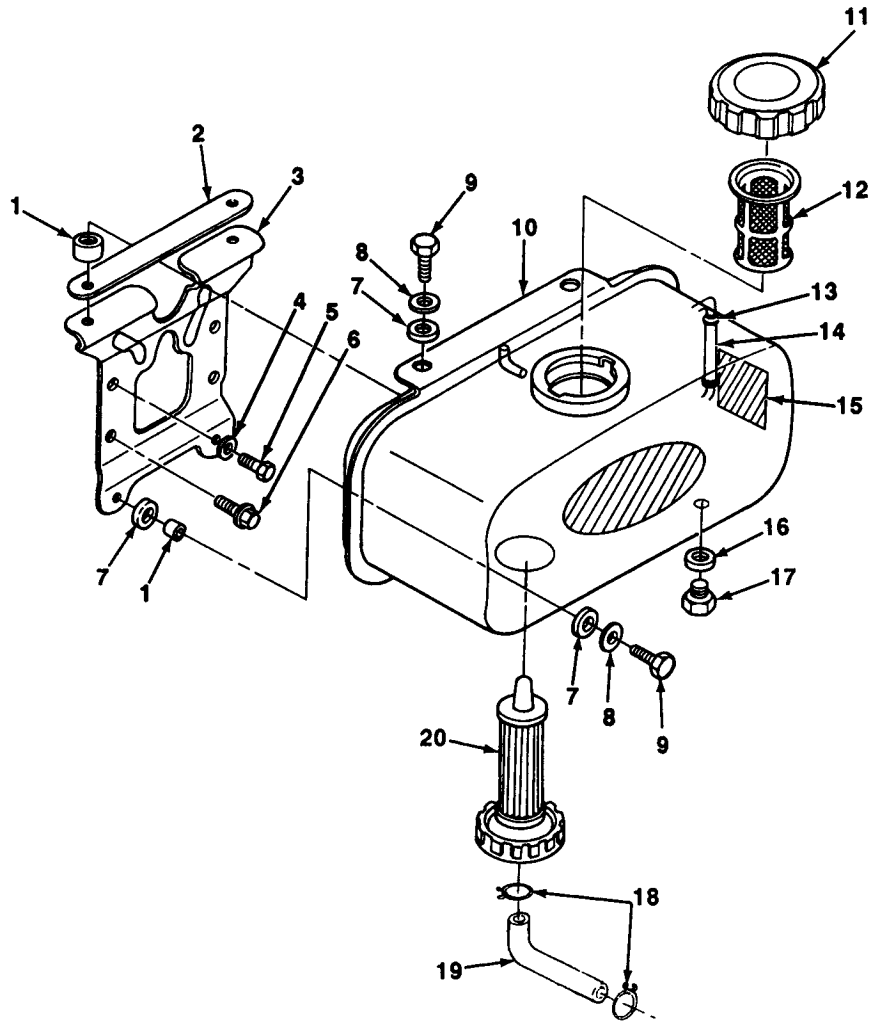


Figure 41. Fuel Tank Assembly.

(1) ITEM NO	(2) SMR CODE	(3) NSN	(4) CAGEC	(5) PART NUMBER	(6) DESCRIPTION AND USABLE ON CODES (UOC)	(7) QTY
<b>GROUP 2935 ENGINE FUEL TANK</b>						
<b>FIG. 41 FUEL TANK ASSEMBLY</b>						
1	PFOZZ	5325013938382	31013	11151-4144-0	GROMMET, NONMETALLIC . . . . .	4
2	PFOZZ	5340013932860	31013	11420-4141-0	PLATE, MOUNTING . . . . .	1
3	PFOZZ	5340013932870	31013	11420-4113-2	BRACKET, MOUNTING . . . . .	1
4	PFOZZ	5310013936780	31013	11420-4137-0	WASHER, FLAT . . . . .	2
5	PFOZZ	5306013934849	31013	01153-50818	BOLT, MACHINE . . . . .	2
6	PAOZZ	5306013934847	31013	01754-60816	BOLT, MACHINE . . . . .	2
7	PFOZZ	5365013931864	31013	11151-7732-0	BUSHING, NONMETALLIC . . . . .	6
8	PFOZZ	5310013936776	31013	04015-50060	WASHER, FLAT . . . . .	4
9	PFOZZ	5305013934850	31013	01053-50620	SCREW, CAP, HEXAGON H . . . . .	4
10	PFOOO	2910013935249	31013	11420-4101-0	TANK, FUEL, ENGINE . . . . .	1
11	PFOZZ	5342013932872	31013	11420-4103-0	.CAP, FILLER OPENING . . . . .	1
12	PFOZZ	2910013935246	31013	13901-4135-0	.FILTER ELEMENT, FLUI . . . . .	1
13	PFOZZ	4730013943739	31013	14301-4236-0	.CLAMP, HOSE . . . . .	2
14	PFOZZ	6680013934021	31013	11420-4171-0	.INDICATOR, SIGHT, LIQ . . . . .	1
15	PAOZZ	9905013950887	31013	11520-8821-0	.PLATE, INSTRUCTION . . . . .	1
16	PCOZZ	5331013935639	31013	04724-00120	.O-RING . . . . .	1
17	PFOZZ	5365013931858	31013	06331-35012	.PLUG, MACHINE THREAD . . . . .	1
18	PAOZZ	4730013594772	S4532	14911-4275-0	CLAMP, HOSE . . . . .	2
19	PAOZZ	4710013935867	31013	11420-4201-0	TUBE, BENT, METALLIC . . . . .	1
20	PAOZZ	2910013935254	31013	11420-43012	FILTER BODY, FLUID . . . . .	1

END OF FIGURE

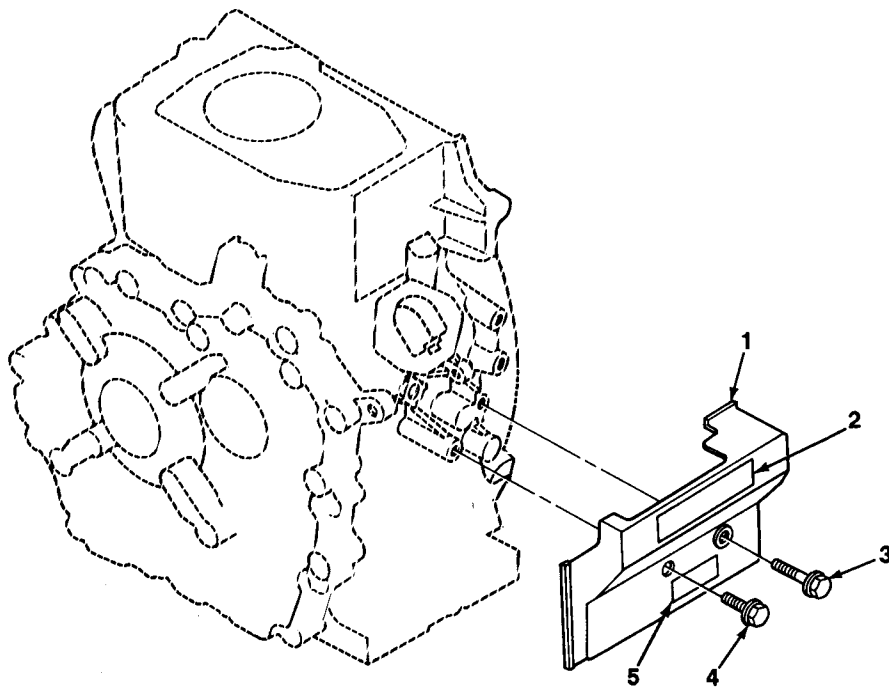


Figure 42. Engine Side Cover.



(1) ITEM NO	(2) SMR CODE	(3) NSN	(4) CAGEC	(5) PART NUMBER	(6) DESCRIPTION AND USABLE ON CODES (UOC)	(7) QTY
<b>GROUP 2936 ENGINE SPEED GOVERNOR AND CONTROLS</b>						
<b>FIG. 42 ENGINE SIDE COVER</b>						
1	PFOZZ	5340013932871	31013	11420-0480-3	COVER,ACCESS.....	1
2	PAOZZ	9905013952087	31013	11420-8755-0	PLATE,INSTRUCTION.....	1
3	PAOZZ	5306013934853	31013	01754-50630	BOLT,MACHINE.....	1
4	PAOZZ	5306013934857	31013	01754-50612	BOLT,MACHINE.....	1
5	PAOZZ	9905013950889	31013	11420-8715-0	PLATE,INSTRUCTION.....	1

END OF FIGURE

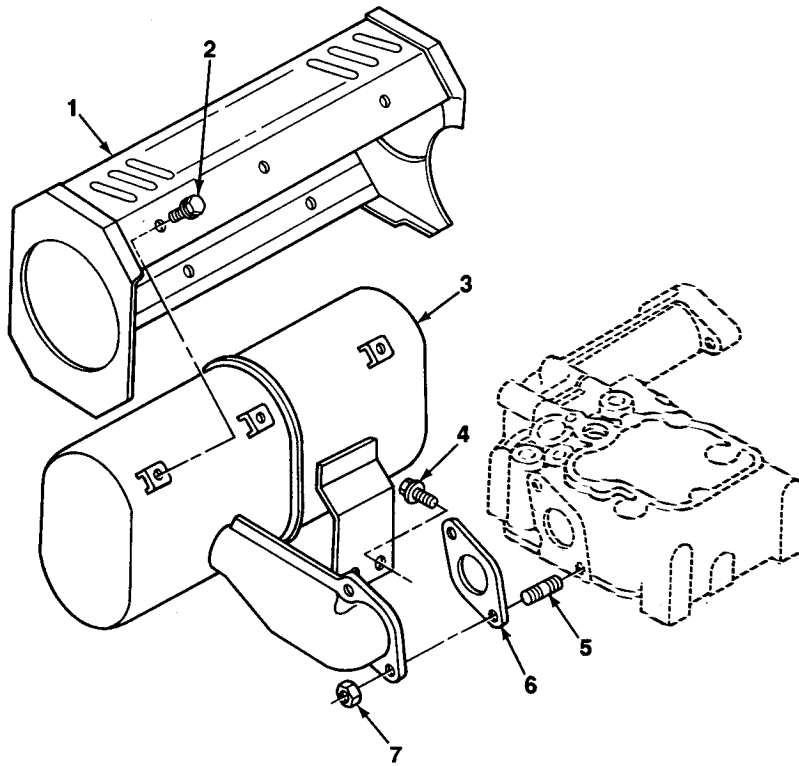


Figure 43. Muffler and Cover Assembly.

(1) ITEM NO	(2) SMR CODE	(3) NSN	(4) CAGEC	(5) PART NUMBER	(6) DESCRIPTION AND USABLE ON CODES (UOC)	(7) QTY
<b>GROUP 2941 ENGINE MUFFLER, EXHAUST, AND TAIL PIPES</b>						
<b>FIG. 43 MUFFLER AND COVER ASSEMBLY</b>						
1	PFOZZ	5340013932863	31013	11520-1270-0	COVER,ACCESS.....	1
2	PFOZZ	5305013934860	31013	11420-9101-0	SCREW,CAP,HEXAGON H .....	6
3	PBOZZ	2990013935247	31013	11520-1205-0	MUFFLER,EXHAUST.....	1
4	PAOZZ	5306013934847	31013	01754-60816	BOLT,MACHINE .....	2
5	PFOZZ	5307013934851	31013	01513-50814	STUD,SHOULDERED .....	2
6	PCOZZ	5330013932864	31013	11420-1223-0	GASKET .....	1
7	PAOZZ	5310013207060	S4532	02114-50080	NUT,SELF-LOCKING,HE .....	2

END OF FIGURE

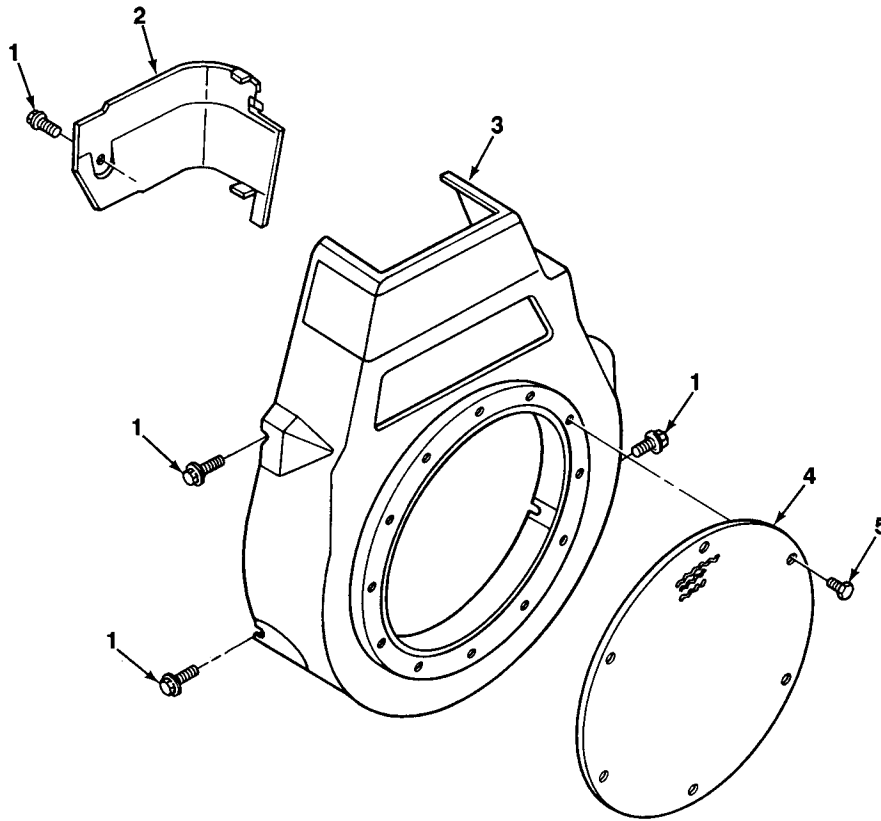


Figure 44. Spiral Case Assembly.

(1) ITEM NO	(2) SMR CODE	(3) NSN	(4) CAGEC	(5) PART NUMBER	(6) DESCRIPTION AND USABLE ON CODES (UOC)	(7) QTY
<b>GROUP 2952 ENGINE COWLING DEFLECTORS, AIR DUCTS, AND SHROUDS</b>						
<b>FIG. 44 SPIRAL CASE ASSEMBLY</b>						
1	PAOZZ	5306013934857	31013	01754-50612	BOLT,MACHINE . . . . .	5
2	PFOZZ	5340013932865	31013	11420-7449-0	COVER,ACCESS . . . . .	1
3	PFOZZ	5340013932873	31013	11420-7408-2	COVER,ACCESS . . . . .	1
4	PFOZZ	5340013932866	31013	11420-7537-0	COVER,ACCESS . . . . .	1
5	PFOZZ	5306013934863	31013	01754-50610	BOLT,MACHINE . . . . .	6

END OF FIGURE

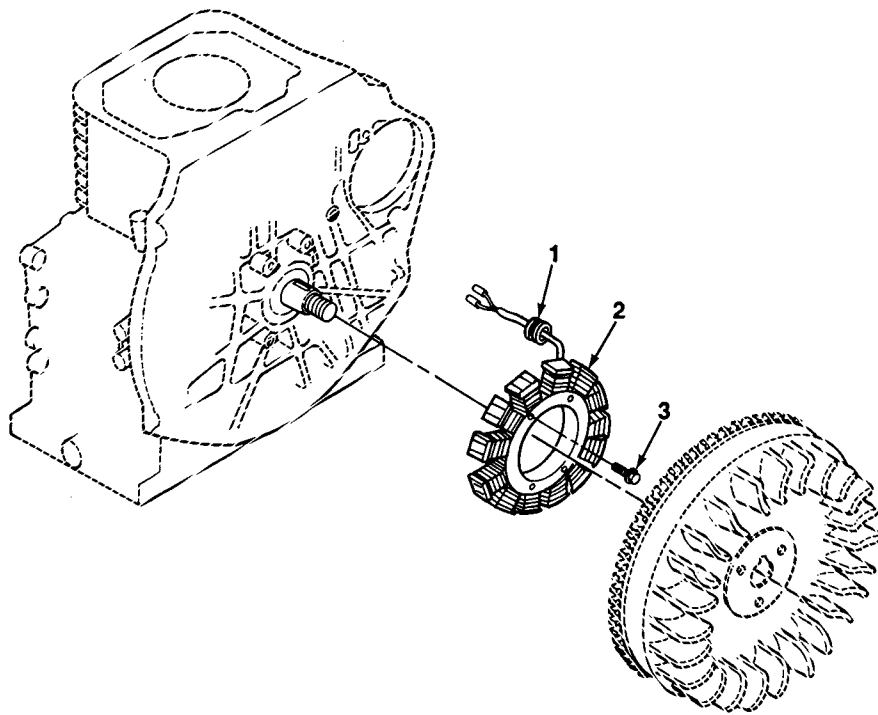


Figure 45. Stator Assembly.

(1) ITEM NO	(2) SMR CODE	(3) NSN	(4) CAGEC	(5) PART NUMBER	(6) DESCRIPTION AND USABLE ON CODES (UOC)	(7) QTY
<b>GROUP 2961 GENERATOR</b>						
<b>FIG. 45 STATOR ASSEMBLY</b>						
1	PAOZZ	5325014389353	31013	11420-6768-0	GROMMET, NONMETALLIC.....	1
2	PAOZZ	2920013935268	31013	11420-6705-0	STATOR ASSEMBLY, IGN.....	1
3	PAOZZ	5306013937080	31013	01754-50620	BOLT, MACHINE.....	4

END OF FIGURE

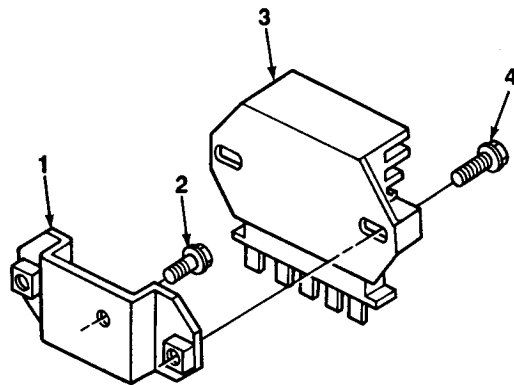


Figure 46. Regulator and Mount.



(1) ITEM NO	(2) SMR CODE	(3) NSN	(4) CAGEC	(5) PART NUMBER	(6) DESCRIPTION AND USABLE ON CODES (UOC)	(7) QTY
<b>GROUP 2962 REGULATOR</b>						
<b>FIG. 46 REGULATOR AND MOUNT</b>						
1	PFOZZ	5340013932868	31013	11420-6461-0	PLATE,MOUNTING .....	1
2	PAOZZ	5306013934847	31013	01754-60816	BOLT,MACHINE .....	1
3	PAOZZ	6110014319890	31013	11420-6460-0	REGULATOR,CURRENT .....	1
4	PAOZZ	5306013937080	31013	01754-50620	BOLT,MACHINE .....	2

END OF FIGURE

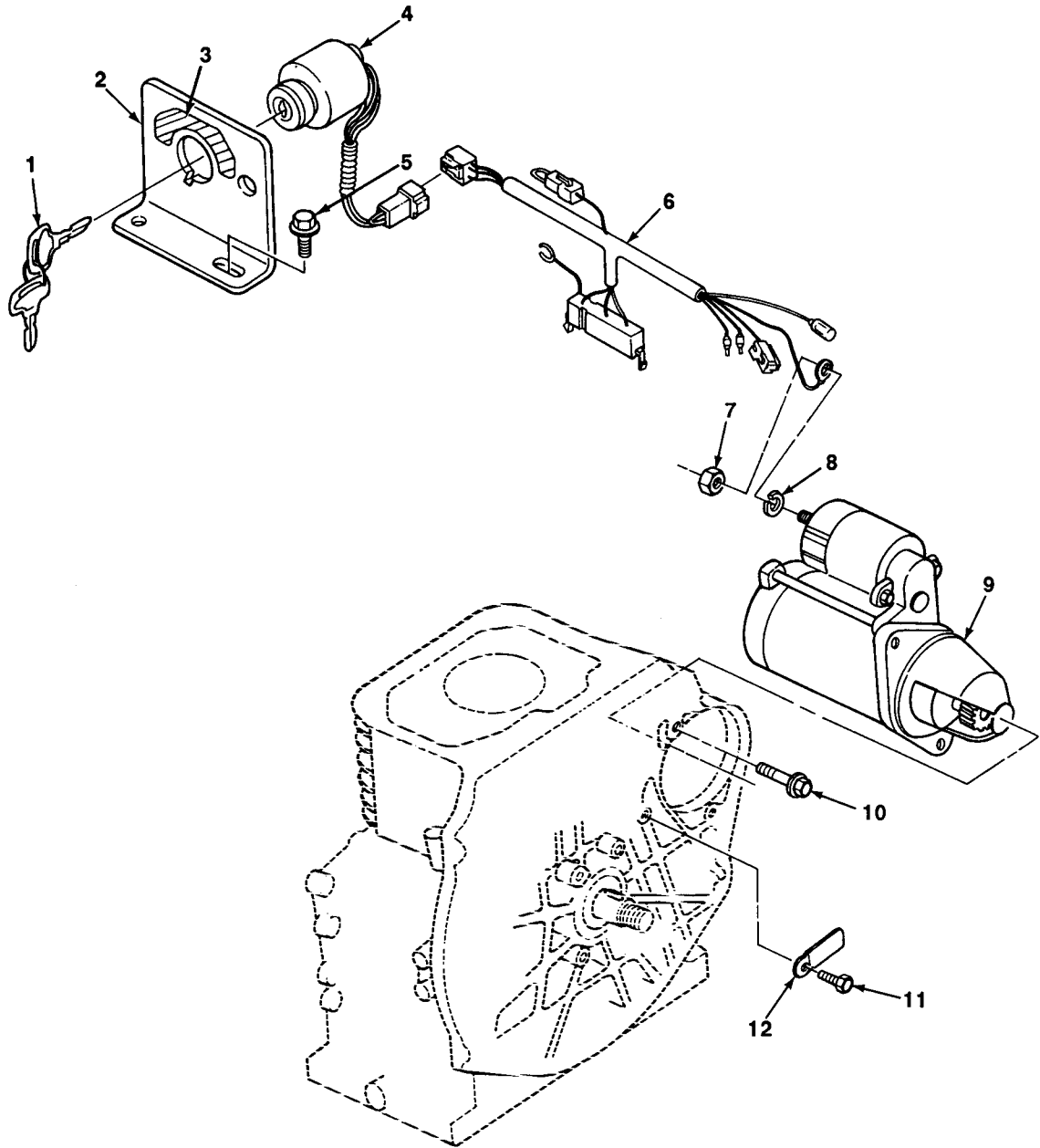


Figure 47. Starter, Switch, and Harness.

(1) ITEM NO	(2) SMR CODE	(3) NSN	(4) CAGEC	(5) PART NUMBER	(6) DESCRIPTION AND USABLE ON CODES (UOC)	(7) QTY
<b>GROUP 2963 STARTER, SOLENOIDS, CIRCUIT BREAKERS, WIRING, AND SWITCHES</b>						
<b>FIG. 47 STARTER, SWITCH, AND HARNESS</b>						
1	PFOZZ	5930013934710	31013	37410-5515-0	KEY, SWITCH . . . . .	2
2	PFOZZ	5340013936310	31013	11420-6360-2	BRACKET, MOUNTING. . . . .	1
3	PAOZZ	9905013950888	31013	11420-8752-0	PLATE, INSTRUCTION. . . . .	1
4	PAOZZ	2920013935869	31013	37410-5911-0	SWITCH, LOCK, IGNITIO. . . . .	1
5	PAOZZ	5306013934857	31013	01754-50612	BOLT, MACHINE . . . . .	1
6	PAOZZ	6150013935115	31013	11420-6575-0	CABLE ASSEMBLY, SPEC . . . . .	1
7	PFOZZ	5310013207060	S4532	02114-50080	NUT, SELF-LOCKING, HE . . . . .	1
8	PFOZZ	5310013213477	S4532	04512-50080	WASHER, LOCK . . . . .	1
9	PAOZZ	2920013934550	31013	11420-6301-0	STARTER, ENGINE, ELEC . . . . .	1
10	PFOZZ	5305013934859	31013	01754-50835	SCREW, CAP, HEXAGON H . . . . .	2
11	PFOZZ	5306013934863	31013	01754-50610	BOLT, MACHINE . . . . .	1
12	PFOZZ	5340013950121	31013	15241-6758-0	CLAMP, LOOP. . . . .	1

END OF FIGURE

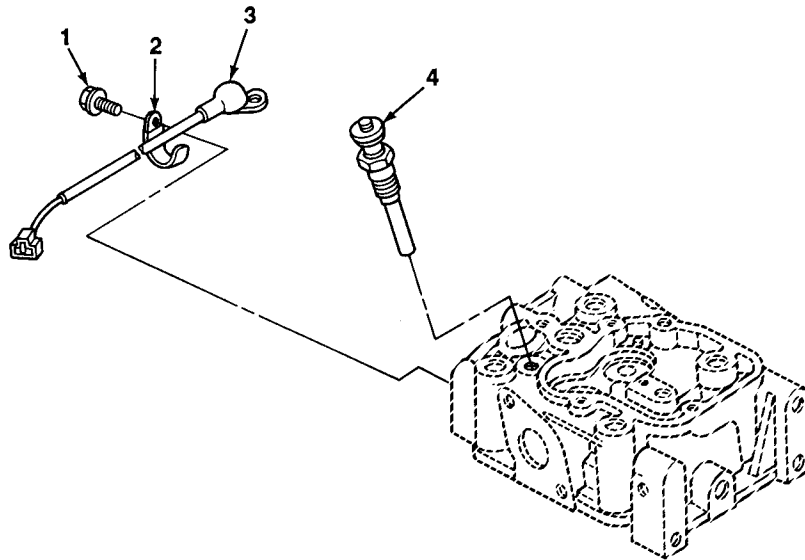


Figure 48. Glow Plug and Cord.

(1) ITEM NO	(2) SMR CODE	(3) NSN	(4) CAGEC	(5) PART NUMBER	(6) DESCRIPTION AND USABLE ON CODES (UOC)	(7) QTY
<b>GROUP 2965 IGNITION COIL</b>						
<b>FIG. 48 GLOW PLUG AND CORD</b>						
1	PFOZZ	5306013934861	31013	01023-50610	BOLT,MACHINE .....	1
2	PFOZZ	5340013950121	31013	15241-6758-0	CLAMP,LOOP.....	1
3	PCOZZ	6150013935104	31013	11420-6556-0	LEAD,ELECTRICAL.....	1
4	PAOZZ	2920013934547	31013	16241-6551-0	GLOW PLUG .....	1

END OF FIGURE

1	2	10
2 THRU 15	3 THRU 7	11 THRU 15

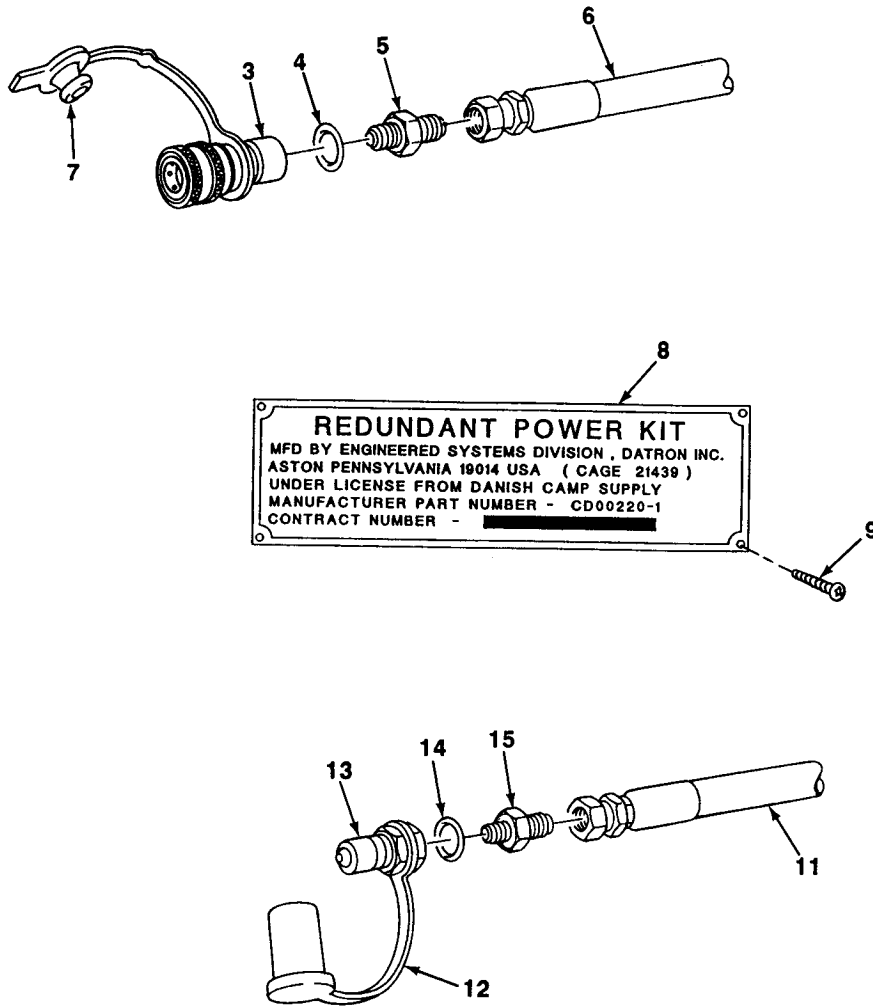


Figure 49. Redundant Power Kit.

(1) ITEM NO	(2) SMR CODE	(3) NSN	(4) CAGEC	(5) PART NUMBER	(6) DESCRIPTION AND USABLE ON CODES (UOC)	(7) QTY
<b>GROUP 33 SPECIAL PURPOSE KITS</b>						
<b>GROUP 3307 SPECIAL PURPOSE KITS</b>						
<b>FIG. 49 REDUNDANT POWER KIT</b>						
1	PCOZZ	1730014062585	21439	8D00220-1	KIT,REDUNDANT POWER. ....	1
2	PCOZZ	4720014061935	21439	8D00220-3	.HOSE ASSEMBLY,NONME. ....	1
3	PAOZZ		30780	H3-62-T8-659	..FITTING,QUICK DIS. ....	2
4	PCOZZ	5331008080794	96906	MS28778-8	..O-RING. ....	2
5	PAOZZ	4730011564835	30780	8F5BX-S	..ADAPTER,STRAIGHT,TU ....	2
6	PCOZZ	4720014061934	21439	8D00052-4	..HOSE ASSEMBLY,NONME ....	1
7	PAOZZ	5340013565057	97111	H3-65M	..CAP,PROTECTIVE,DUST ....	2
8	PFOZZ	9905014211715	21439	8D00062-24	.PLATE,IDENTIFICATIO. ....	1
9	PFOZZ	5305014171546	45722	NO. 4-5/16	.SCREW,MACHINE #4 X 5/16. ....	4
10	PCOZZ	4720014061936	21439	8D00220-2	.HOSE ASSEMBLY,NONME. ....	1
11	PCOZZ	4720014061934	21439	8D00052-4	..HOSE ASSEMBLY,NONME ....	1
12	PAOZZ	5340013074395	97111	H3-66M	..PLUG,PROTECTIVE,DUS ....	2
13	PAOZZ		30780	H3-63-T8-659	..COUPLING HALF,QUICK. ....	2
14	PCOZZ	5331008080794	96906	MS28778-8	..O-RING. ....	2
15	PAOZZ	4730011564835	30780	8F5BX-S	..ADAPTER,STRAIGHT,TU ....	2

END OF FIGURE

1  
2 THRU 26

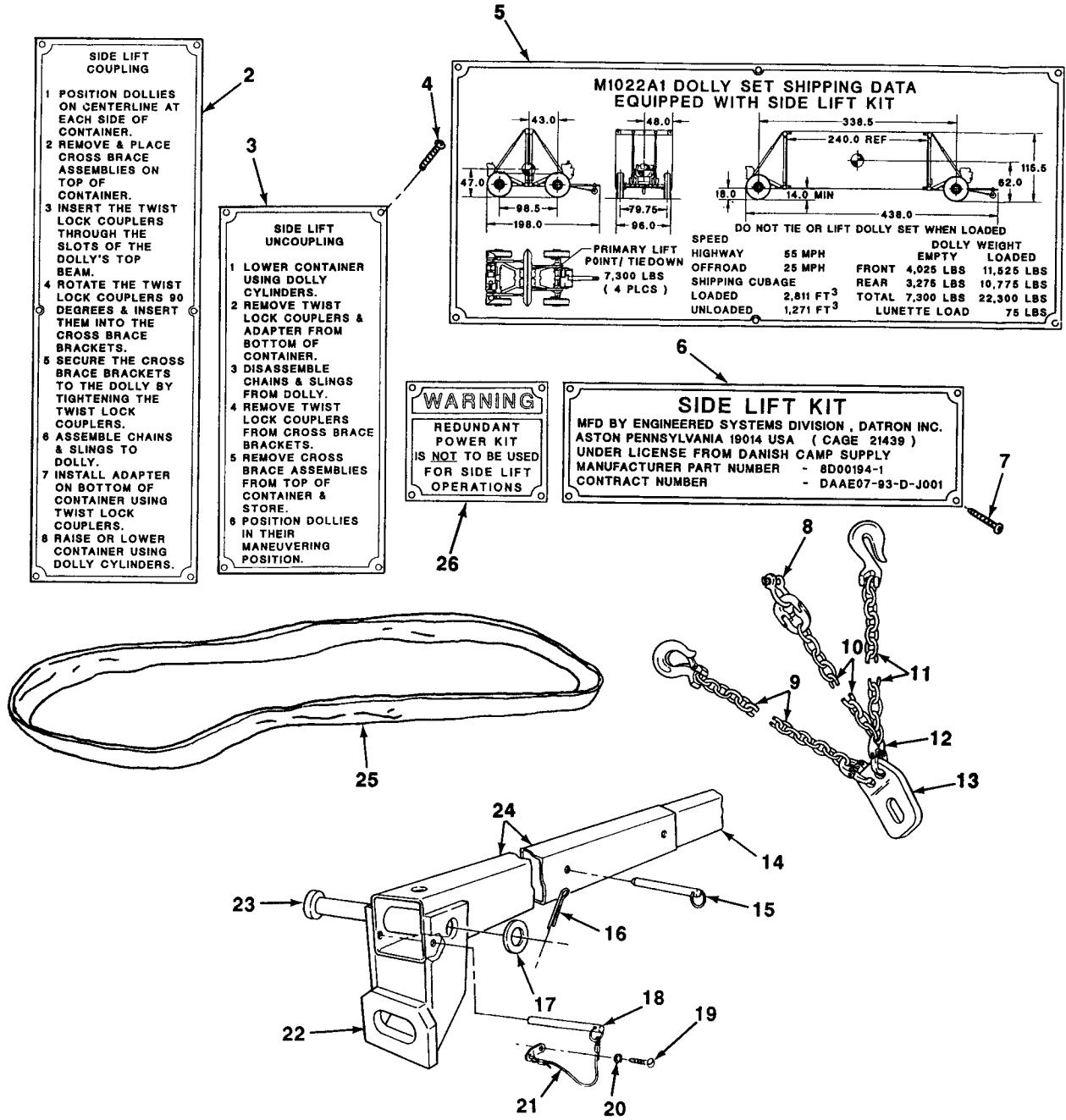


Figure 50. Side Lift Kit Component Parts.



(1) ITEM NO	(2) SMR CODE	(3) NSN	(4) CAGEC	(5) PART NUMBER	(6) DESCRIPTION AND USABLE ON CODES (UOC) GROUP 3307 SPECIAL PURPOSE KITS FIG. 50 SIDE LIFT KIT COMPONENT PARTS	(7) QTY
1	PDFZZ	3950014180930	21439	8D00194-1	PARTS KIT,LINEAR AC . . . . .	1
2	PFOZZ	9905014202785	21439	8D00062-11	.PLATE,INSTRUCTION . . . . .	1
3	PFOZZ	9905014216243	21439	8D00062-12	.PLATE,INSTRUCTION . . . . .	1
4	XDOZZ	5305014171545	45722	NO. 4-3/16	.SCREW,MACHINE #4 X 3/16. . . . .	10
5	PFOZZ	9905014210349	21439	8D00062-22	.PLATE,IDENTIFICATION. . . . .	1
6	PFOZZ	9905014212970	21439	8D00062-23	.PLATE,INSTRUCTION . . . . .	1
7	PFOZZ	5305014171546	45722	NO. 4-5/16	.SCREW,MACHINE #4 X 5/16. . . . .	18
8	PFOZZ	4030014169994	76257	G-209-A-5/8	.SHACKLE . . . . .	4
9	PFOZZ	4010014171548	21439	8D00209-3	.CHAIN ASSEMBLY,SING AXLE . . . . .	1
10	PFOZZ	4010014059922	21439	8D00209-2	.CHAIN ASSEMBLY,SING TAKE-UP. . . . .	4
11	PFOZZ	4010014171547	21439	8D00209-1	.CHAIN ASSEMBLY,SING LIFTING. . . . .	4
12	PAOZZ	4010012268812	75535	A-337-1/2	.LINK,CHAIN,DETACHAB . . . . .	8
13	PFOZZ	5340014268784	21439	8D00201-1	.BRACKET,MOUNTING . . . . .	4
14	PFOZZ		21439	8D00199-1	.PLATE,MOUNTING. . . . .	2
15	PFOZZ		21439	8D00202-5	.PIN,QUICK RELEASE. . . . .	4
16	PAOZZ	5315000590217	96906	MS24665-624	.PIN,COTTER. . . . .	4
17	PAOZZ	5310002826903	88044	AN960-2016	.WASHER,FLAT 1 1/4 . . . . .	4
18	PFOZZ	5315014285920	21439	8D00202-6	.PIN,QUICK RELEASE. . . . .	2
19	PAOZZ	5305000581082	96906	MS51861-34	.SCREW,TAPPING #8 X 1/4 . . . . .	2
20	PAOZZ	5310000453299	96906	MS35338-42	.WASHER,LOCK #8 . . . . .	2
21	PFOZZ	3990014188756	96652	79-08	.LANYARD ASSY . . . . .	2
22	PFOZZ	2590014185568	21439	8D00200-1	.BRACKET,VEHICULAR C . . . . .	4
23	PFOZZ	5315014168905	0AYE7	8D00060-8	.PIN,STRAIGHT,HEADED . . . . .	4
24	PFOZZ		21439	8D00198-1	.PLATE,MOUNTING. . . . .	2
25	PFOZZ	3940014183504	21439	8D00208-1	.SLING,ENDLESS . . . . .	4
26	PFOZZ	7690014318639	21439	8D00062-27	.LABEL . . . . .	2

END OF FIGURE

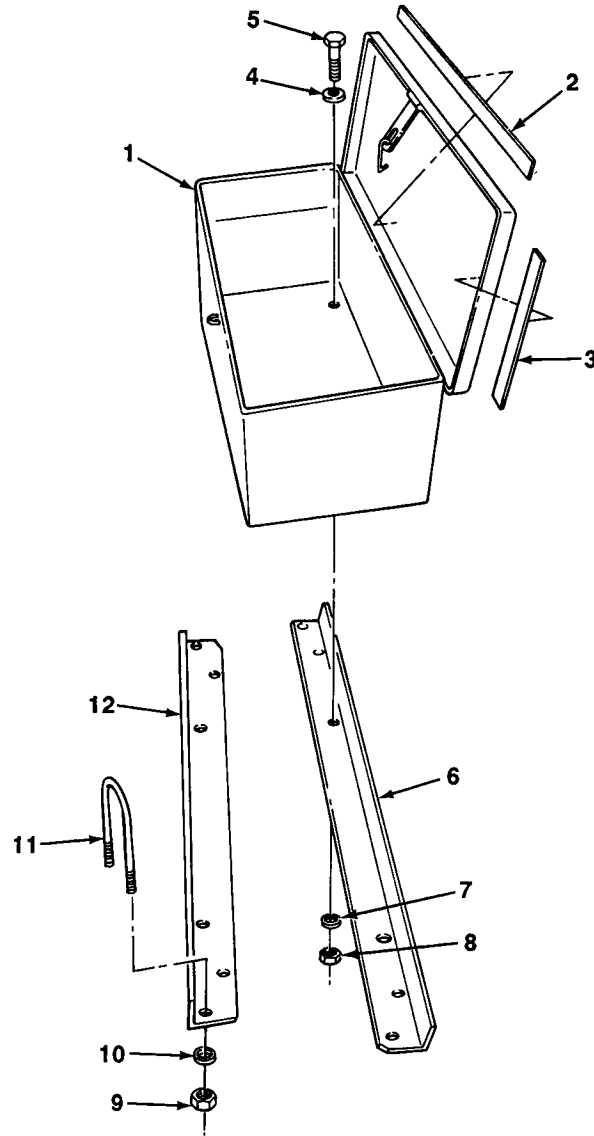
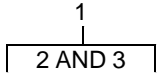


Figure 51. Side Lift Kit Storage Box.

(1) ITEM NO	(2) SMR CODE	(3) NSN	(4) CAGEC	(5) PART NUMBER	(6) DESCRIPTION AND USABLE ON CODES (UOC)	(7) QTY
<b>GROUP 3307 SPECIAL PURPOSE KITS</b>						
<b>FIG. 51 SIDE LIFT KIT STORAGE BOX</b>						
1	PFOZZ	2540014185575	21439	8D00228-1	.BOX,ACCESSORIES STO .....	1
2	PCOZZ	5330014313107	21439	8D00228-4	..SEAL,PLAIN .....	2
3	PCOZZ	5330014313100	21439	8D00228-5	..SEAL,PLAIN .....	2
4	PAOZZ	5310001670766	80205	AN970-4	.WASHER,FLAT 1/4.....	4
5	PAOZZ	5305000712505	80204	B1821BH025C088 N	.SCREW,CAP,HEXAGON H 1/4-20 X 7/8 .....	4
6	PFOZZ	5340014172485	21439	8D00229-1	.BRACKET,ANGLE .....	1
7	PAOZZ	5310001411795	88044	AN960-416	.WASHER,FLAT 1/4.....	4
8	PAOZZ	5310000881251	96906	MS51922-1	.NUT,SELF-LOCKING,HE 1/4-20 .....	4
9	PAOZZ	5310000874652	96906	MS51922-17	.NUT,SELF-LOCKING,HE 3/8-16 .....	8
10	PAOZZ	5310001670821	88044	AN960-616	.WASHER,FLAT 3/8.....	8
11	PFOZZ	5306014178590	0EXZ4	8D00227-2	.BOLT,U.....	4
12	PFOZZ	5340014172483	0EXZ4	8D00229-2	.BRACKET,ANGLE .....	1

END OF FIGURE

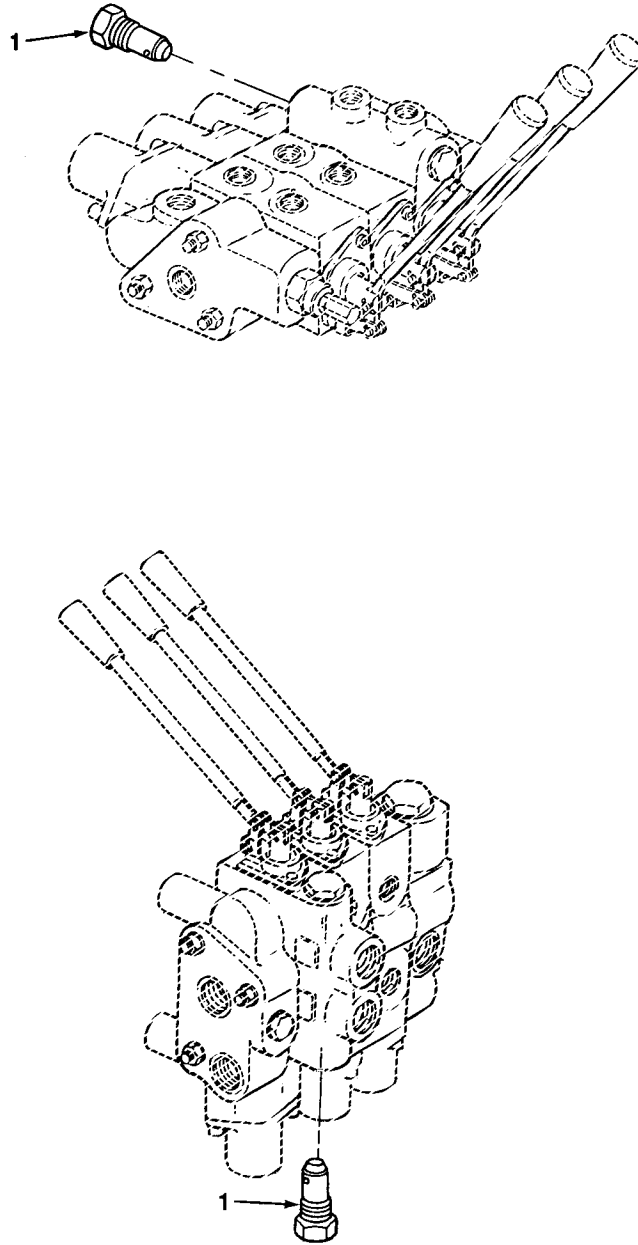


Figure 52. Side Lift Kit Hydraulic Valve Plug.

Section II

TM 9-2330-390-14&P, C4

(1) ITEM NO	(2) SMR CODE	(3) NSN	(4) CAGEC	(5) PART NUMBER	(6) DESCRIPTION AND USABLE ON CODES (UOC)	(7) QTY
					<b>GROUP 3307 SPECIAL PURPOSE KITS</b>	
					<b>FIG. 52 SIDE LIFT KIT HYDRAULIC VALVE PLUG</b>	
1	PFOZZ	4820014194120	29260	660280004	.VALVE,RELIEF,PRESSU.....	2

END OF FIGURE

1  
| 2 THRU 15 |

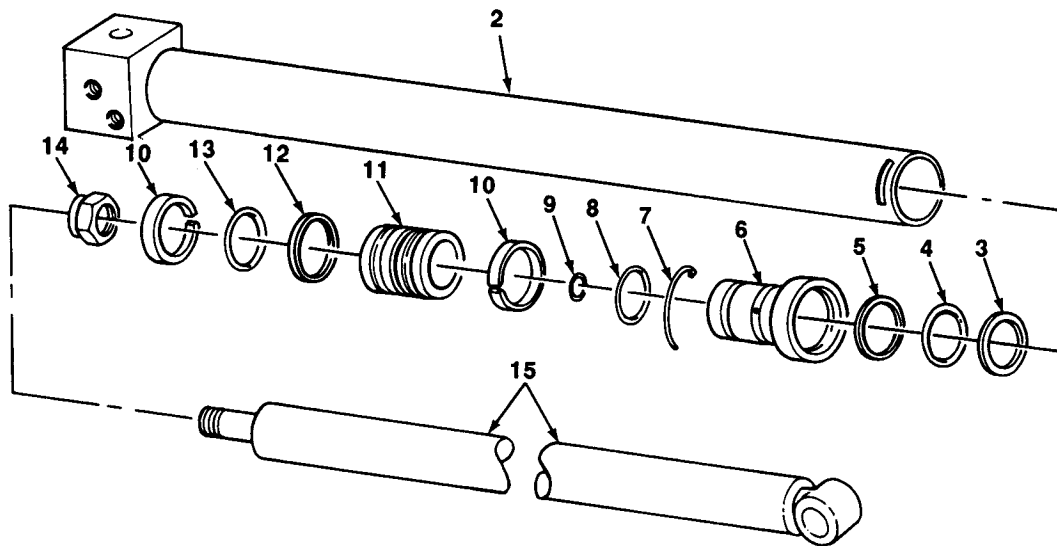


Figure 53. Side Lift Kit Positioning Cylinder.

(1) ITEM NO	(2) SMR CODE	(3) NSN	(4) CAGEC	(5) PART NUMBER	(6) DESCRIPTION AND USABLE ON CODES (UOC) GROUP 3307 SPECIAL PURPOSE KITS FIG. 53 SIDE LIFT KIT POSITIONING CYLINDER	(7) QTY
1	PFOFF	3040014179823	21439	8D00191-1	..CYLINDER ASSEMBLY,A .....	4
2	PFFZZ	3040014184572	21439	8D00235-4	..CYLINDER,ACTUATING .....	1
3	KFFZZ		21439	8D00235-22	..WIPER,ROD .....	1
					PART OF KIT P/N 8D00235-25	
4	KFFZZ		21439	8D00235-26	..SEAL,BACKUP .....	1
					PART OF KIT P/N 8D00235-25	
5	KFFZZ		21439	8D00235-20	..O-RING .....	1
					PART OF KIT P/N 8D00235-25	
6	PFFZZ	3040014184574	21439	8D00235-23	..HEAD,LINEAR ACTUATI .....	1
7	PFFZZ	3040014181718	21439	8D00235-24	..RING,ROD,PISTON .....	1
8	KFFZZ		21439	8D00235-21	..O-RING .....	1
					PART OF KIT P/N 8D00235-25.	
9	KFFZZ		21439	8D00235-9	..O-RING .....	1
					PART OF KIT P/N 8D00235-25.	
10	KFFZZ		21439	8D00235-16	..RING,WEAR .....	2
					PART OF KIT P/N 8D00235-25	
11	PFFZZ	3040014181734	21439	8D00235-17	..PISTON,LINEAR ACTUA .....	1
12	KFFZZ		21439	8D00235-18	..O-RING EXPANDER .....	1
					PART OF KIT P/N 8D00235-25	
13	KFFZZ		21439	8D00235-15	..SEAL,PISTON .....	1
					PART OF KIT P/N 8D00235-25	
14	PFFZZ	5310014171543	21439	8D00235-10	..NUT,SELF-LOCKING,CA .....	1
15	PFFZZ	3040014183026	21439	8D00235-11	..ROD,PISTON,LINEAR A .....	1

END OF FIGURE

1  
2 THRU 36

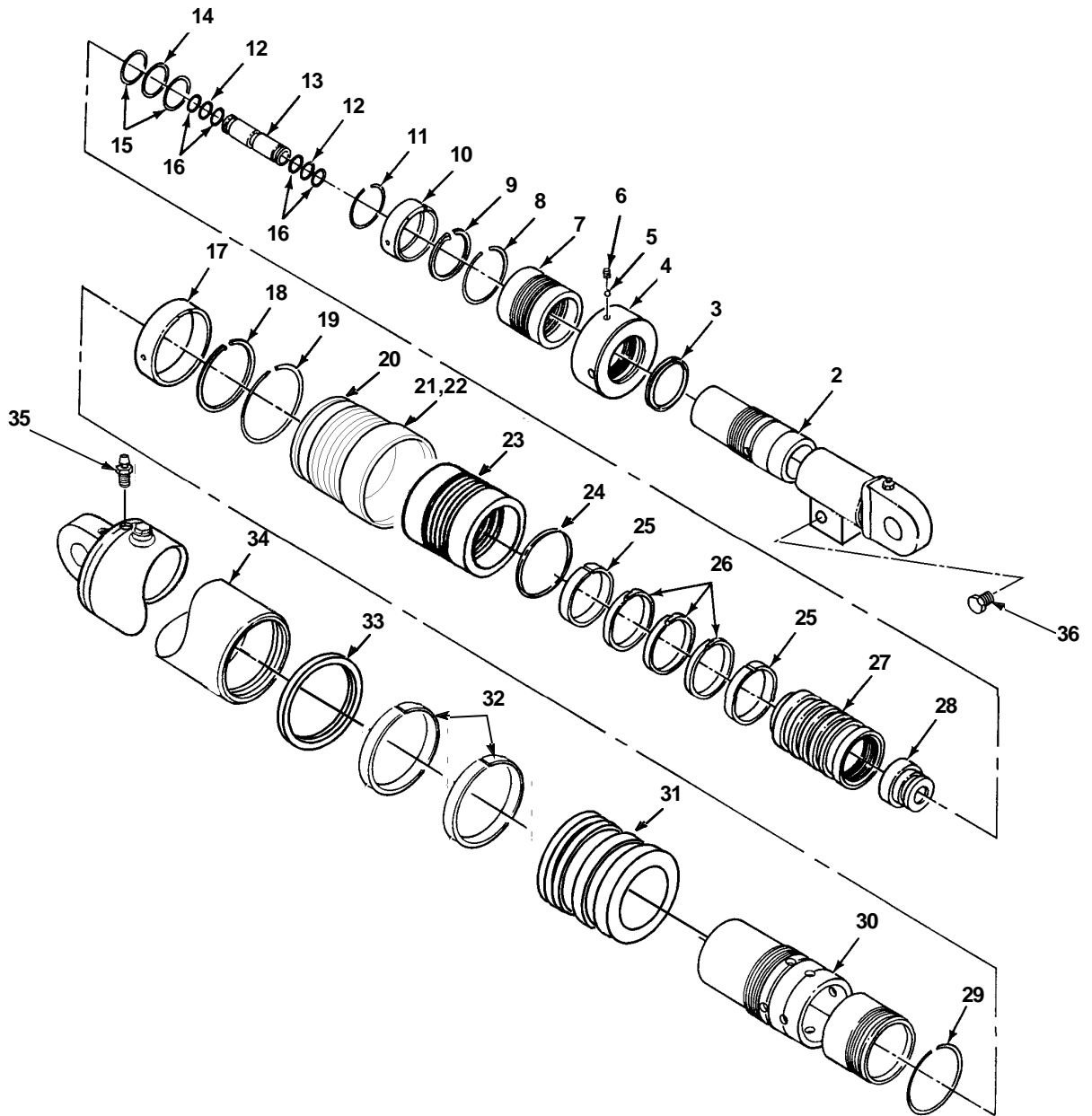


Figure 54. Side Lift Kit Lift Cylinder.



(1) ITEM NO	(2) SMR CODE	(3) NSN	(4) CAGEC	(5) PART NUMBER	(6) DESCRIPTION AND USABLE ON CODES (UOC)	(7) QTY
<b>GROUP 3307 SPECIAL PURPOSE KITS</b>						
<b>FIG. 54 SIDE LIFT KIT LIFT CYLINDER</b>						
1	PFOHH	3040014209855	21439	8D00193-1	..CYLINDER ASSEMBLY,A .....	4
2	PFHZZ		21439	8D00234-5	..CYLINDER ASSEMBLY,A .....	1
3	KFHZZ		21439	8D00234-34	..WIPER .....	1
					PART OF KIT P/N 8D00234-37	
4	PFHZZ	5342014268904	21439	8D00234-13	..CAP,FILLER OPENING .....	1
5	PFHZZ		21439	8D00234-16	..RING,WIPER .....	2
6	PFHZZ	5305014171542	21439	8D00234-15	..SETSCREW .....	2
7	KFHZZ		21439	8D00234-24	..PACKING SET .....	1
					PART OF KIT P/N 8D00234-37	
8	PFHZZ	3040014183102	21439	8D00234-22	..RING,ROD,PISTON .....	1
9	PFHZZ	5325014059921	21439	8D00234-17	..RING,RETAINING .....	1
10	PFHZZ	5340014663781	21439	8D00234-10	..STOP MECHANICAL .....	1
11	PFHZZ	3040014183031	21439	8D00234-23	..RING,ROD,PISTON .....	1
12	KFHZZ		21439	8D00234-26	..O-RING .....	2
					PART OF KIT P/N 8D00234-37	
13	PFHZZ	3040014293287	21439	8D00234-6	..ROD,PISTON,LINEAR A .....	1
14	KFHZZ		21439	8D00234-27	..O-RING .....	1
					PART OF KIT P/N 8D00234-37.	
15	KFHZZ		21439	8D00234-33	..WASHER,BACK-UP .....	2
					PART OF KIT P/N 8D00234-37	
16	KFHZZ		21439	8D00234-32	..WASHER,BACK-UP .....	4
					PART OF KIT P/N 8D00234-37	
17	PFHZZ	5325014169990	21439	8D00234-11	..RING,RETAINING .....	1
18	PFHZZ	5325014169993	21439	8D00234-18	..RING,RETAINING .....	1
19	PFHZZ		21439	8D00234-20	..RING,RETAINING .....	1
20	KFHZZ		21439	8D00234-25	..PACKING SET .....	1
					PART OF KIT P/N 8D00234-37	
21	PFHZZ		21439	8D00234-12	..CAP,FILLER .....	1
22	PFHZZ		21439	8D00234-44	..T-SEAL .....	1
23	PFHZZ		21439	8D00234-42	..BUSHING,DU .....	1
24	KFHZZ		21439	8D00234-30	..BEARING RING .....	2
					PART OF KIT P/N 8D00234-37	
24	KFHZZ		21439	8D00234-35	..WIPER .....	1
					PART OF KIT P/N 8D00234-37	
25	KFHZZ		21439	8D00234-30	..BEARING RING .....	2
					PART OF KIT P/N 8D00234-37	
26	KFHZZ		21439	8D00234-29	..RING,PISTON .....	3
					PART OF KIT P/N 8D00234-37	
27	PAHZZ	3040014651259	29260	071700117	..PISTON,LINEAR ACTUA .....	1
28	PFHZZ		21439	8D00234-38	..SEAL,RING,METAL .....	1

(1) ITEM NO	(2) SMR CODE	(3) NSN	(4) CAGEC	(5) PART NUMBER	(6) DESCRIPTION AND USABLE ON CODES (UOC) GROUP 3307 SPECIAL PURPOSE KITS FIG. 54 SIDE LIFT KIT LIFT CYLINDER - CONT	(7) QTY
29	PFHZZ	3040014181846	21439	8D00234-21	..RING,ROD,PISTON . . . . .	1
30	PFHZZ	3040014293289	21439	8D00234-4	..CYLINDER,ACTUATING . . . . .	1
31	PFHZZ		21439	8D00234-9	..PISTON,LINER ACTUA . . . . .	1
32	KFHZZ		21439	8D00234-31	..BEARING RING . . . . . PART OF KIT P/N 8D00234-37	2
33	KFHZZ		21439	8D00234-28	..RING,PISTON. . . . . PART OF KIT P/N 8D00234-37	1
34	PFHZZ	3040014184576	21439	8D00234-7	..CYLINDER,ACTUATING . . . . .	1
35	PFOZZ	4820014185573	21439	8D00234-39	..VALVE,BLEEDER,HYDRA . . . . .	1
36	PAOZZ	4820014180937	21439	POCI-10-N-O-XX	..VALVE,CHECK . . . . .	1

END OF FIGURE



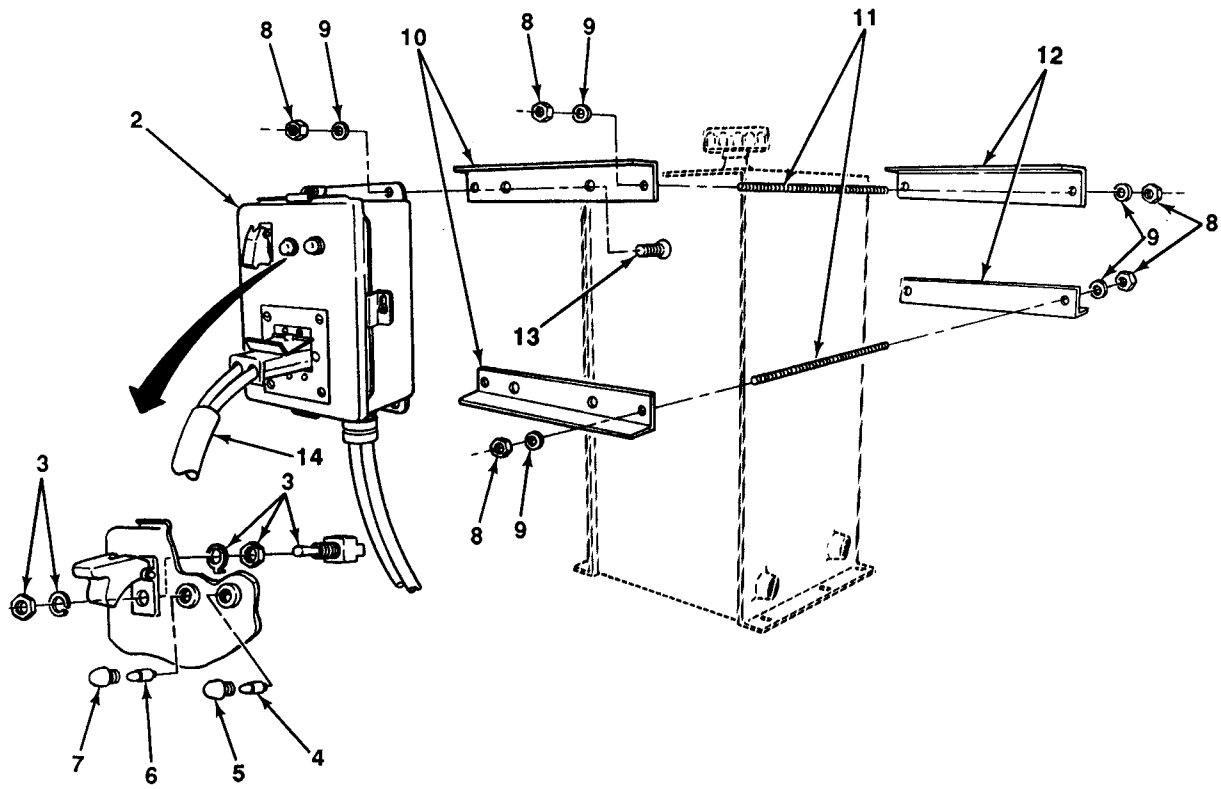
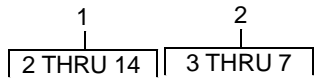


Figure 54A. Cold Start Kit.

(1) ITEM NO	(2) SMR CODE	(3) NSN	(4) CAGEC	(5) PART NUMBER	(6) DESCRIPTION AND USABLE ON CODES (UOC)	(7) QTY
<b>GROUP 3307 SPECIAL PURPOSE KITS</b>						
<b>FIG. 54A COLD START KIT</b>						
1	PDOZZ	6110014666395	21439	8D00350-1	KIT,COLD START . . . . .	1
2	PAOZZ	5930014672945	21439	8D00346-1	.SWITCH,BOX . . . . .	1
3	PAOZZ	5930006831628	96906	MS24523-22	..SWITCH,TOGGLE . . . . .	1
4	PAOZZ	6240009651381	00303	382	..LAMP,INCANDESCENT . . . . .	1
5	PAOZZ	6210010034277	83330	367-8430-0932-503	..LIGHT,INDICATOR . . . . .	1
6	PAOZZ		F0022	327	..LAMP,INCANDESCENT . . . . .	1
7	PAOZZ	6210012184050	83330	367-8430-0931-503	..LIGHT,PANEL . . . . .	1
8	PAOZZ	5310000881251	96906	MS51922-1	.NUT,SELF-LOCKING,HE . . . . .	12
9	PAOZZ	5310008094058	96906	MS27183-10	.WASHER,FLAT . . . . .	12
10	PAOZZ	5340014381615	21439	8D00347-1	.BRACKET,ANGLE . . . . .	2
11	PAOZZ	5340014387023	21439	8D00350-6	.ROD END,THREADED . . . . .	4
12	PAOZZ	5340014387485	21439	8D00347-2	.BRACKET,MOUNTING . . . . .	2
13	PAOZZ	5305014120890	96906	MS24693-95	.SCREW,MACHINE . . . . .	4
14	PAOZZ	6150014669167	21439	8D00362-1	.JUMPER CABLE,BATTER . . . . .	1

END OF FIGURE



Section II

TM 9-2330-390-14&P, C4

(1) ITEM NO	(2) SMR CODE	(3) NSN	(4) CAGEC	(5) PART NUMBER	(6) DESCRIPTION AND USABLE ON CODES (UOC)	(7) QTY
<b>GROUP 94 REPAIR KITS</b>						
<b>GROUP 9401 REPAIR KITS</b>						
<b>FIG. KITS</b>						
PCFZZ		21439	8D00051-17		KIT,SEAL.....	1
					PACKING,PREFORMED ( 1) 31-9	
					PACKING,PREFORMED ( 1) 31-13	
					RING,WEAR ( 2) 31-10	
					SEAL,BACKUP ( 1) 31-8	
					SEAL,PISTON ( 1) 31-12	
					SEAL,ROD ( 1) 31-5	
					WIPER,ROD ( 1) 31-4	
PCFZZ		21439	8D00152-21		KIT,SEAL.....	1
					PACKING,PREFORMED ( 1) 32-13	
					PACKING,PREFORMED ( 1) 32-12	
					PACKING,PREFORMED ( 1) 32-7	
					RING,WEAR ( 2) 32-10	
					SEAL,BACKUP ( 1) 32-8	
					SEAL,PISTON ( 1) 32-14	
					SEAL,ROD ( 1) 32-4	
					WIPER,ROD ( 1) 32-3	
PCFZZ	5330013934783	21439	8D00196-86		PARTS KIT,SEAL REPL.....	1
					PACKING,PREFORMED ( 12) 29-10	
					PACKING,PREFORMED ( 4) 29-11	
PFFZZ	3040013937546	21439	8D00196-89		PARTS KIT,LINEAR AC.....	1
					ADAPTER,SPOOL END ( 3) 29-6	
					CLEVIS ( 3) 29-18	
					HANDLE ( 3) 29-16	
					KNOB,HANDLE ( 3) 29-17	
					LINK ( 3) 29-5	
					PIN,CLEVIS ( 3) 29-7	
					PIN,CLEVIS ( 6) 29-4	
					PIN,COTTER ( 9) 29-8	
					SCREW,CAP ( 6) 29-9	

Section II

TM 9-2330-390-14&P, C4

(1) ITEM NO	(2) SMR CODE	(3) NSN	(4) CAGEC	(5) PART NUMBER	(6) DESCRIPTION AND USABLE ON CODES (UOC)	(7) QTY
<b>GROUP 94 REPAIR KITS</b>						
<b>GROUP 9401 REPAIR KITS</b>						
<b>FIG. KITS</b>						
PCFZZ	5330014080885	21439		8D00234-37	PARTS KIT,SEAL REPL .....	1
					BEARING RING ( 2) 54-25	
					BEARING RING ( 2) 54-32	
					O-RING ( 2) 54-12	
					O-RING ( 1) 54-14	
					PACKING SET ( 1) 54-7	
					PACKING SET ( 1) 54-20	
					PARTS KIT,SEAL REPL ( 1) 54-3	
					PARTS KIT,SEAL REPL ( 1) 54-32	
					PARTS KIT,SEAL REPL ( 1) 54-24	
					RING,PISTON ( 1) 54-33	
					RING,PISTON ( 1) 54-26	
					WASHER,BACK-UP ( 1) 54-16	
					WASHER,BACK-UP ( 1) 54-15	
					WIPER ( 1) 54-3	
					WIPER ( 1) 54-24	
PCFZZ		21439		8D00235-25	SEAL KIT .....	1
					O-RING ( 1) 53-9	
					O-RING ( 1) 53-12	
					O-RING ( 1) 53-5	
					O-RING ( 1) 53-8	
					RING,WEAR ( 1) 53-10	
					SEAL,BACKUP ( 1) 53-4	
					SEAL,PISTON ( 1) 53-13	
					WIPER,ROD ( 1) 53-3	

END OF FIGURE



Section II

TM 9-2330-390-14&P, C4

(1) ITEM NO	(2) SMR CODE	(3) NSN	(4) CAGEC	(5) PART NUMBER	(6) DESCRIPTION AND USABLE ON CODES (UOC)	(7) QTY
1	PAOZZ	9505002212650	96906	MS20995C20	WIRE,NONELECTRICAL.....	1

**GROUP 95 GENERAL USE STANDARDIZED PARTS**  
**GROUP 9501 BULK MATERIEL**  
**FIG. BULK**

END OF FIGURE

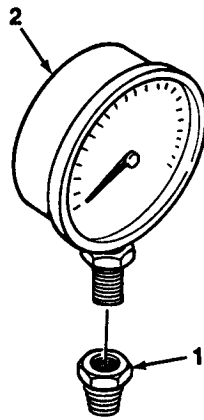


Figure 55. Special Tools.

(1) ITEM NO	(2) SMR CODE	(3) NSN	(4) CAGEC	(5) PART NUMBER	(6) DESCRIPTION AND USABLE ON CODES (UOC)	(7) QTY
					<b>GROUP 26 TOOLS AND TEST EQUIPMENT</b>	
					<b>GROUP 2604 SPECIAL TOOLS</b>	
					<b>FIG. 55 SPECIAL TOOLS</b>	
1	PEOZZ	4730002220135	10001	2256784PC3	ADAPTER,STRAIGHT,PI	
2	PEOZZ	6685013737976	61349	151469	GAGE,PRESSURE,DIAL	
					END OF FIGURE	



## CROSS-REFERENCE INDEXES

## NATIONAL STOCK NUMBER INDEX

STOCK NUMBER	FIG.	ITEM	STOCK NUMBER	FIG.	ITEM
4730-00-011-3176	13	17	5310-00-087-4652	20	33
	16	12		20	64
2610-00-029-0563	18	3		21	3
5305-00-044-4153	22	3		35	11
5310-00-044-6477	20	61		51	9
	34	6	5310-00-088-1251	7	5
	35	7		20	55
5310-00-045-3296	15	14		25	4
5310-00-045-3299	9	20		51	8
	20	17		54A	8
	50	20	5935-00-115-2307	5	7
5305-00-050-9231	15	15		6	4
5305-00-052-6921	30	26	5305-00-115-9526	14	4
5305-00-054-6654	6	13		29	20
5305-00-054-6655	6	12	5310-00-141-1795	7	6
5305-00-054-6656	1	18		20	56
	3	28		30	27
5305-00-054-6659	1	17		51	7
5305-00-054-6671	5	14	5310-00-144-8453	2	8
5305-00-058-1082	9	21	5975-00-152-1075	2	29
	20	16	6240-00-155-8717	4	7
	50	19		5	20
5315-00-059-0217	33	3	5306-00-156-2338	3	33
	50	16		5	30
5305-00-059-3660	5	26	5306-00-156-2339	1	23
	30	32	5310-00-167-0766	51	4
5305-00-059-3661	2	33	5310-00-167-0821	13	23
	4	8		14	2
	30	47		15	19
5305-00-059-3676	26	4		20	24
5305-00-059-3677	26	6		20	32
5305-00-059-5432	26	4		35	10
5305-00-068-0500	2	15		51	10

## CROSS-REFERENCE INDEXES

## NATIONAL STOCK NUMBER INDEX

STOCK NUMBER	FIG.	ITEM	STOCK NUMBER	FIG.	ITEM
5305-00-068-0501	1	11	5310-00-167-0823	20	7
	3	21	5310-00-167-0825	20	10
5305-00-068-0502	2	12	5310-00-167-0826	20	11
	3	15		24	6
5305-00-068-0511	28	11	5310-00-167-0828	24	7
5306-00-068-0513	17	2		33	5
4730-00-068-8656	13	12	5310-00-167-1304	20	4
5305-00-071-2505	20	66	5935-00-167-7775	4	3
	51	5		5	22
5975-00-074-2072	1	14	5330-00-171-8363	25	3
	2	25	5330-00-172-1919	13	2
	3	22		13	29
5310-00-080-6004	20	65		14	12
5310-00-087-4652	13	24		14	14
	14	1	5340-00-200-3045	30	46
	15	20	5340-00-200-8559	2	32
	20	23	9905-00-202-3639	26	3
	26	7	5310-00-407-9566	28	12
9905-00-205-2795	26	7	5310-00-407-9566	28	12
	2	30	5305-00-411-0682	3	27
	4	11	4730-00-427-5121	13	32
	5	29		14	7
	30	35		15	30
5310-00-208-9255	30	35	5310-00-449-2376	20	67
	30	35	5310-00-449-2376	20	67
	1	16	4730-00-469-7797	13	5
5310-00-209-0788	3	26	4730-00-511-1677	13	4
	3	26	4730-00-511-1677	13	4
9505-00-221-2650	BULK	1	5310-00-515-8058	22	7
4730-00-222-0135	55	1	5330-00-526-5783	28	2
4730-00-225-0699	30	22	5340-00-531-6857	30	30
5305-00-225-3843	7	8	5310-00-543-2739	5	13
	25	2	5310-00-543-5933	4	9
5310-00-225-6993	23	6		5	27
	24	2	2640-00-555-2824	18	4
5306-00-225-8498	20	50	5310-00-582-5677	25	5

## CROSS-REFERENCE INDEXES

## NATIONAL STOCK NUMBER INDEX

STOCK NUMBER	FIG.	ITEM	STOCK NUMBER	FIG.	ITEM
5306-00-225-8499	16	6	5310-00-582-5965	1	12
	34	8		2	17
5306-00-226-4825	28	13	5310-00-584-5272	3	23
	34	3		22	2
	35	8		4730-00-595-0083	13
5306-00-226-4834	35	9		13	28
5315-00-234-1664	24	8		14	11
	33	6		14	13
5315-00-234-1673	20	37		16	8
4730-00-249-9714	13	10		16	9
5305-00-269-3211	13	22	4730-00-595-0251	15	10
	15	18	4730-00-595-3108	16	2
	20	45	2530-00-603-5768	17	16
	20	57	5310-00-615-1556	2	31
	21	1		4	10
5305-00-269-3217	20	31		5	28
5305-00-269-3219	20	53		30	49
5310-00-269-4040	20	9	5310-00-616-1124	33	2
4730-00-277-5056	30	36	5310-00-616-3555	6	9
4730-00-277-7331	16	18	4730-00-618-5372	30	6
4730-00-278-4822	13	18		30	6
	15	21	4730-00-618-5381	30	12
5310-00-282-6903	50	17	5310-00-637-9541	28	10
5310-00-285-8124	7	7		29	19
4730-00-287-3281	15	13	5975-00-642-7261	3	29
4730-00-287-4852	13	3	5975-00-660-5962	5	8
	16	14		6	5
	4	6	5310-00-722-5998	1	6
5940-00-399-6676	5	10		3	13
	5	25		6	10
	6	7	5310-00-732-0558	2	27
	17	9	5930-00-683-1628	54A	3

## CROSS-REFERENCE INDEXES

## NATIONAL STOCK NUMBER INDEX

STOCK NUMBER	FIG.	ITEM	STOCK NUMBER	FIG.	ITEM
4730-00-407-0571	14	6	2530-00-738-9061	17	18
	16	13	5310-00-765-3197	2	4
5310-00-767-9425	23	7	5310-00-934-9764	2	7
5310-00-773-7618	20	51	6240-00-965-1381	54A	4
	21	4	5310-00-982-6813	1	7
5331-00-804-5695	30	17		3	14
	30	17		6	11
5331-00-808-0794	30	3	5310-00-982-6814	5	16
	49	4	5310-00-984-3806	16	7
	49	14		20	47
5310-00-809-4058	54A	9		34	7
5310-00-809-8546	2	6		35	6
4730-00-810-0059	15	12	5305-00-984-6195	22	9
5310-00-811-3494	22	6	5305-00-984-6214	2	5
5310-00-820-6653	12	17	5975-00-985-6630	30	37
5305-00-821-3869	35	3		30	37
4730-00-822-5609	30	9	5310-00-997-1888	1	13
	30	9		2	18
5310-00-832-9719	24	5		3	24
5935-00-833-8561	4	4	9905-00-999-7369	27	8
	5	23	9905-00-999-7370	27	9
5970-00-833-8562	4	5	6210-01-003-4277	54A	5
	5	9	6220-01-085-3391	6	8
	5	24	6220-01-088-5915	5	17
	6	6	2640-01-093-2842	18	4
2540-00-835-9039	22	1	5995-01-096-0733	6	2
5315-00-839-5821	33	7	5935-01-141-0877	2	13
5315-00-842-3044	9	24	4730-01-156-4835	30	21
5935-00-846-3883	2	16		49	5
	3	19		49	15
5935-00-846-3884	1	9	5315-01-171-0750	20	21
5310-00-850-6881	9	6	4730-01-195-7331	30	15



## CROSS-REFERENCE INDEXES

## NATIONAL STOCK NUMBER INDEX

STOCK NUMBER	FIG.	ITEM	STOCK NUMBER	FIG.	ITEM
5305-00-855-0960	9	7	5975-01-207-0229	2	24
	11	3	5340-01-213-5535	3	32
5305-00-858-5558	20	15	6210-01-218-4050	54A	7
5310-00-877-5795	20	8	4010-01-226-8812	50	12
5310-00-880-5978	5	15	5310-01-267-1685	24	1
5305-00-881-0705	20	2		33	8
6240-00-889-1799	5	5	2610-01-281-0675	18	1
5310-00-889-2589	1	21	4730-01-289-9536	13	13
	3	30	2610-01-292-3009	18	1
	5	31	5310-01-304-8733	1	22
	26	5		3	31
5305-00-889-3002	2	3		5	32
5310-00-897-6145	26	1		26	2
5925-00-900-1903	2	9	5340-01-307-4395	30	23
5310-00-902-0423	20	38		49	12
4730-00-903-7652	30	4	5325-01-317-4273	22	13
	30	4	5310-01-320-7060	43	7
4730-00-933-0727	30	18		47	7
5310-00-934-9761	1	15	5331-01-320-9556	38	9
	3	25	5310-01-321-3477	47	8
5975-01-321-7295	1	10	2530-01-393-2675	10	1
	2	14	5340-01-393-2859	39	6
	3	20	5340-01-393-2860	41	2
2530-01-329-7523	17	16	5331-01-393-2861	37	8
4730-01-334-5710	30	25		38	5
5940-01-346-1336	1	4	5331-01-393-2862	39	15
	3	11	5340-01-393-2863	43	1
5340-01-356-5057	30	1	5330-01-393-2864	43	6
	49	7	5340-01-393-2865	44	2
5975-01-356-6962	27	14	5340-01-393-2866	44	4
5315-01-359-1451	9	26	5340-01-393-2868	46	1
4730-01-359-4772	41	18	5342-01-393-2869	37	9
4730-01-359-4773	39	2	5340-01-393-2870	41	3

## CROSS-REFERENCE INDEXES

## NATIONAL STOCK NUMBER INDEX

STOCK NUMBER	FIG.	ITEM	STOCK NUMBER	FIG.	ITEM
6685-01-373-7976	55	2	5340-01-393-2871	42	1
4730-01-385-6972	13	30	5342-01-393-2872	41	11
	15	24	5340-01-393-2873	44	3
5360-01-388-5783	13	31	5331-01-393-2874	40	3
	15	23	5340-01-393-2876	37	6
5315-01-392-8539	24	9	5342-01-393-2877	35	4
5315-01-392-8542	24	11	5340-01-393-2878	10	2
5315-01-392-9391	33	9	5306-01-393-3741	9	12
5315-01-392-9393	24	11		11	6
5315-01-392-9394	33	4	5307-01-393-3742	9	17
5315-01-392-9395	20	40	5330-01-393-3744	37	7
5315-01-392-9397	20	20	6220-01-393-4019	5	18
	33	1	6680-01-393-4020	38	6
4030-01-393-0836	12	7	6680-01-393-4021	41	14
5315-01-393-0837	10	4	6680-01-393-4023	34	2
5360-01-393-0839	12	11	6220-01-393-4024	4	1
5365-01-393-0840	10	3	2920-01-393-4547	48	4
5320-01-393-0842	20	35	2530-01-393-4548	13	11
5340-01-393-1315	23	2	4820-01-393-4549	13	9
5315-01-393-1316	36	1	2920-01-393-4550	47	9
5315-01-393-1318	19	3	4820-01-393-4551	15	11
5365-01-393-1858	41	17	4820-01-393-4552	16	15
5365-01-393-1859	38	7	4820-01-393-4553	13	20
5340-01-393-1860	35	2		15	7
5340-01-393-1862	20	60	4820-01-393-4555	13	27
5365-01-393-1864	41	7		15	22
3010-01-393-2160	28	6	4720-01-393-4572	30	8
4730-01-393-2162	39	9		30	8
4730-01-393-2164	38	1	4720-01-393-4575	30	7
6220-01-393-2331	5	19	4720-01-393-4576	30	13
6220-01-393-2332	5	2	4720-01-393-4577	30	10
6220-01-393-2333	5	18	4720-01-393-4578	15	4
6220-01-393-2335	5	2	4720-01-393-4579	15	8

## CROSS-REFERENCE INDEXES

## NATIONAL STOCK NUMBER INDEX

STOCK NUMBER	FIG.	ITEM	STOCK NUMBER	FIG.	ITEM
5120-01-393-2582	7	2	4720-01-393-4580	16	16
5340-01-393-2609	17	4	4720-01-393-4581	30	41
2510-01-393-2666	20	1	5930-01-393-4710	47	1
2530-01-393-2672	10	1	5330-01-393-4783	KITS	
5306-01-393-4847	39	12	2940-01-393-5248	40	4
	40	9	2910-01-393-5249	41	10
	41	6	4720-01-393-5250	14	15
	43	4	3040-01-393-5251	20	42
	46	2	4720-01-393-5252	14	10
5306-01-393-4849	41	5	2910-01-393-5254	41	20
5305-01-393-4850	41	9	4820-01-393-5255	15	1
5307-01-393-4851	43	5	2530-01-393-5256	15	17
5306-01-393-4853	42	3	3040-01-393-5258	20	42
5307-01-393-4854	39	7	2510-01-393-5259	24	10
5330-01-393-4855	1	20	2920-01-393-5268	45	2
	2	26	2530-01-393-5270	10	5
	3	3	2530-01-393-5271	17	12
5305-01-393-4856	40	8	2590-01-393-5273	20	44
5306-01-393-4857	42	4	4820-01-393-5274	29	3
	44	1	3040-01-393-5275	9	25
	47	5	4820-01-393-5276	29	1
5305-01-393-4859	37	3	4720-01-393-5277	30	19
	47	10	4720-01-393-5278	30	14
5305-01-393-4860	43	2	2530-01-393-5279	15	25
5306-01-393-4861	48	1	5330-01-393-5637	2	19
5306-01-393-4862	37	4		3	9
5306-01-393-4863	44	5	5330-01-393-5638	40	10
	47	11	5331-01-393-5639	38	8
5306-01-393-4864	37	5		41	16
5340-01-393-4865	20	59	5306-01-393-5641	12	3
5331-01-393-4866	12	9	5307-01-393-5642	9	23
2510-01-393-5087	20	12	5310-01-393-5643	12	8
2510-01-393-5091	20	68	5310-01-393-5644	19	13

## CROSS-REFERENCE INDEXES

## NATIONAL STOCK NUMBER INDEX

STOCK NUMBER	FIG.	ITEM	STOCK NUMBER	FIG.	ITEM
6150-01-393-5104	48	3	5305-01-393-5645	12	14
6150-01-393-5107	2	22	5310-01-393-5646	12	16
6150-01-393-5108	2	21	5310-01-393-5647	17	8
6150-01-393-5109	3	6	5310-01-393-5648	17	7
6150-01-393-5110	3	5	5310-01-393-5649	19	15
6220-01-393-5111	21	2	5340-01-393-5650	20	54
6150-01-393-5112	8	1	5307-01-393-5652	17	14
6150-01-393-5113	8	3	5310-01-393-5653	17	11
6150-01-393-5114	2	23	2510-01-393-5744	20	39
6150-01-393-5115	47	6	4710-01-393-5867	41	19
6150-01-393-5118	8	2	2510-01-393-5868	20	39
2510-01-393-5168	20	52	2920-01-393-5869	47	4
2530-01-393-5169	9	1	2510-01-393-5870	20	1
2530-01-393-5173	19	17	2590-01-393-5871	20	13
3040-01-393-5240	20	42	4710-01-393-5872	39	14
4710-01-393-5241	38	2	2590-01-393-5873	20	3
3040-01-393-5243	20	42	4940-01-393-5874	3	2
4710-01-393-5244	39	3	2530-01-393-5875	11	1
4710-01-393-5245	38	4	2530-01-393-5876	12	12
2910-01-393-5246	41	12	2530-01-393-5877	13	26
2990-01-393-5247	43	3	2530-01-393-5878	29	2
2530-01-393-5879	12	2	4710-01-393-7540	13	21
4720-01-393-5880	30	42	2815-01-393-7541	36	2
2530-01-393-5881	12	10	2530-01-393-7543	17	15
4720-01-393-5884	30	44	2540-01-393-7544	9	16
4720-01-393-5886	30	43	2530-01-393-7545	19	9
6150-01-393-6171	1	8	3040-01-393-7546	KITS	
6150-01-393-6172	3	18	2540-01-393-7972	23	4
6150-01-393-6173	3	7	3040-01-393-7983	32	1
6150-01-393-6208	3	17	5325-01-393-8382	41	1
5342-01-393-6306	38	11	6110-01-393-8897	3	1
5340-01-393-6307	39	4	6110-01-393-8898	1	1
5340-01-393-6308	39	13	5340-01-393-9366	20	36

## CROSS-REFERENCE INDEXES

## NATIONAL STOCK NUMBER INDEX

STOCK NUMBER	FIG.	ITEM	STOCK NUMBER	FIG.	ITEM
5340-01-393-6309	12	15	4320-01-393-9843	28	1
5340-01-393-6310	47	2	4320-01-393-9844	34	1
5310-01-393-6312	12	13	2815-01-393-9846	35	1
5310-01-393-6313	19	1	5340-01-394-0005	23	5
5307-01-393-6314	17	14	4820-01-394-0480	29	12
5340-01-393-6315	12	5	4820-01-394-0541	29	13
5310-01-393-6316	12	4	5140-01-394-2021	25	1
4820-01-393-6363	29	15	5935-01-394-2106	3	16
2510-01-393-6526	24	3	5310-01-394-2370	17	11
5310-01-393-6776	41	8	4730-01-394-3739	41	13
5310-01-393-6777	9	15	4710-01-394-4779	20	58
5310-01-393-6779	40	7	4710-01-394-4780	20	30
5310-01-393-6780	41	4	3120-01-394-7284	20	5
5310-01-393-6781	39	5	5315-01-394-7521	20	49
5310-01-393-6782	36	3	5315-01-394-7522	20	28
5310-01-393-6783	35	5	5315-01-394-7523	20	19
5340-01-393-6784	12	6	3110-01-394-7718	17	10
5310-01-393-6785	36	4	9905-01-394-9841	27	4
5340-01-393-6786	20	58	9905-01-394-9843	27	3
5340-01-393-6788	21	6	9905-01-394-9845	27	2
5340-01-393-7079	20	48	9905-01-394-9849	27	17
5306-01-393-7080	39	8	9905-01-394-9851	27	20
	45	3	9905-01-394-9853	27	5
	46	4	9905-01-394-9856	27	18
5310-01-393-7081	9	9	9905-01-394-9859	27	21
	11	12	5340-01-395-0121	47	12
5340-01-393-7082	21	5		48	2
5340-01-393-7083	20	29	9905-01-395-0887	41	15
2530-01-393-7163	14	8	9905-01-395-0888	47	3
5935-01-393-7232	3	8	9905-01-395-0889	42	5
3040-01-393-7529	31	1	9905-01-395-2087	42	2
2910-01-393-7530	38	10	9905-01-395-2088	27	6
2590-01-393-7531	20	3	9905-01-395-2089	27	1

## CROSS-REFERENCE INDEXES

## NATIONAL STOCK NUMBER INDEX

STOCK NUMBER	FIG.	ITEM	STOCK NUMBER	FIG.	ITEM
2940-01-393-7532	40	1	5340-01-395-2166	14	3
3040-01-393-7533	28	5	9905-01-395-2712	27	16
2540-01-393-7534	22	4	9905-01-395-2713	27	13
2530-01-393-7535	13	16	9905-01-395-4077	27	19
	16	1	5325-01-405-9921	54	9
4010-01-405-9922	50	10	7690-01-418-0407	6	3
4010-01-406-0511	9	18	5331-01-418-0621	17	5
4710-01-406-1921	16	17	3950-01-418-0930	50	1
4710-01-406-1922	15	9	4820-01-418-0937	31	2
4730-01-406-1923	9	4		54	36
	11	7	3040-01-418-1718	53	7
4720-01-406-1924	14	16	3040-01-418-1734	53	11
4710-01-406-1925	15	16	3040-01-418-1846	54	29
4710-01-406-1927	16	10	3040-01-418-3026	53	15
4710-01-406-1928	16	3	3040-01-418-3031	54	11
4720-01-406-1934	49	6	3040-01-418-3102	54	8
	49	11	3940-01-418-3504	50	25
4720-01-406-1935	49	2	3040-01-418-4572	53	2
4720-01-406-1936	49	10	3040-01-418-4574	53	6
1730-01-406-2585	49	1	3040-01-418-4576	54	34
6150-01-406-2906	7	3	7690-01-418-5084	27	10
2590-01-406-3526	21	6	5975-01-418-5108	3	10
6140-01-406-8993	7	1	4720-01-418-5287	30	39
5330-01-408-0885	KITS		2540-01-418-5567	20	22
5305-01-412-0890	54A	13	2590-01-418-5568	50	22
5315-01-416-8903	50	15	2590-01-418-5571	22	5
5315-01-416-8905	50	23	4820-01-418-5573	54	35
5325-01-416-9990	54	17	5975-01-418-6041	1	3
5365-01-416-9992	33	10	5310-01-418-6243	1	2
	33	10		2	28
5325-01-416-9993	54	18	3990-01-418-8755	9	19
4030-01-416-9994	50	8		20	18
5305-01-417-1542	54	6		22	8

## CROSS-REFERENCE INDEXES

## NATIONAL STOCK NUMBER INDEX

STOCK NUMBER	FIG.	ITEM	STOCK NUMBER	FIG.	ITEM
5310-01-417-1543	53	14	3990-01-418-8756	20	27
5305-01-417-1545	27	23		50	21
5305-01-417-1546	27	22	5315-01-419-2308	20	14
	49	9	5340-01-419-3838	9	5
	50	7		11	2
4010-01-417-1547	50	11	4820-01-419-4120	52	1
4010-01-417-1548	50	9	5310-01-419-5660	19	10
5340-01-417-2483	51	12	1730-01-419-6112	37	2
5340-01-417-2485	51	6	4820-01-419-7040	29	14
7690-01-417-3455	27	12	4720-01-419-7872	30	20
7690-01-417-3461	27	11	9905-01-420-2785	50	2
5306-01-417-5740	20	26	5340-01-420-4519	37	1
6210-01-417-7034	5	4	3040-01-420-9855	54	1
5340-01-417-7276	21	2	9905-01-421-0349	50	5
5340-01-417-7277	21	5	9905-01-421-1714	27	7
5340-01-417-7278	30	28	9905-01-421-1715	49	8
6220-01-417-7414	6	1	9905-01-421-2970	50	6
5306-01-417-8590	51	11	3990-01-421-4290	25	6
3040-01-417-9823	53	1	9905-01-421-6243	50	3
7690-01-418-0407	4	2	4730-01-421-6441	19	7
	5	11		22	11
	5	21		22	15
4820-01-421-8062	24	4	6110-01-431-9890	46	3
5310-01-421-9481	17	6	5340-01-432-2903	29	16
5340-01-421-9482	34	5	5340-01-432-4862	20	34
4730-01-422-4155	13	25	5340-01-438-1615	54A	10
4730-01-422-4160	13	14	5340-01-438-7023	54A	11
4730-01-422-5721	13	15	5340-01-438-7485	54A	12
5306-01-422-5966	9	2	5325-01-438-9353	45	1
	11	9	5330-01-464-9956	17	13
2590-01-422-7462	20	25	3040-01-465-1259	54	27
2530-01-422-7473	16	4	2610-01-465-5823	18	1
4720-01-422-7846	13	6	6110-01-465-7511	2	11

## CROSS-REFERENCE INDEXES

## NATIONAL STOCK NUMBER INDEX

STOCK NUMBER	FIG.	ITEM	STOCK NUMBER	FIG.	ITEM
9905-01-423-2590	5	12	3040-01-466-0004	32	11
9905-01-423-2596	5	12	3040-01-466-0005	31	11
4820-01-423-4847	16	11	4720-01-466-2736	13	8
5315-01-424-7838	20	41	5340-01-466-3781	54	10
2510-01-426-2443	20	12	6140-01-466-5416	7	3
5340-01-426-8784	50	13	6110-01-466-6395	54A	1
5342-01-426-8904	54	4	6150-01-466-9167	54A	14
2590-01-428-1697	19	6	5365-01-466-9524	32	6
	22	12	5930-01-467-2945	54A	2
	22	14	5315-01-473-2046	19	5
5315-01-428-5920	50	18	5340-01-431-4073	9	3
4720-01-428-9691	15	2		11	8
4720-01-428-9692	14	9	5310-01-431-4074	15	28
	15	29	7690-01-431-8639	50	26
4730-01-429-1321	9	13	7690-01-431-8641	27	21
3040-01-429-3287	54	13	7690-01-431-8642	27	15
3040-01-429-3289	54	30	7690-01-431-8645	27	7
5310-01-429-5029	9	14			
5315-01-429-7277	9	22			
	20	43			
	22	10			
5310-01-429-8520	9	11			
	11	10			
5340-01-429-9351	2	10			
5306-01-430-3411	19	2			
4820-01-431-2389	29	1			
5330-01-431-3100	51	3			
5330-01-431-3107	51	2			
4010-01-431-3239	9	8			
	11	4			
5330-01-431-3620	39	16			
5331-01-431-3621	39	15			



## CROSS-REFERENCE INDEXES

## PART NUMBER INDEX

CAGEC	PART NUMBER	STOCK NUMBER	FIG.	ITEM
58536	A-A-52483	9905-00-999-7369	27	8
75535	A-337-1/2	4010-01-226-8812	50	12
93957	ALI-00-C	7690-01-418-5084	27	10
93957	ALI-23	7690-01-417-3461	27	11
93957	ALI-6	7690-01-417-3455	27	12
81352	AN316-8R	5310-00-167-1304	20	4
88044	AN4C6A	5306-00-156-2338	3	33
			5	30
88044	AN4C7A	5306-00-156-2339	1	23
88044	AN938-8	4730-00-277-5056	30	36
88044	AN960-1016	5310-00-167-0825	20	10
88044	AN960-1216	5310-00-167-0826	20	11
			24	6
88044	AN960-1616	5310-00-167-0828	24	7
			33	5
88044	AN960-2016	5310-00-282-6903	50	17
88044	AN960-2016L	5310-00-616-1124	33	2
88044	AN960-416	5310-00-141-1795	7	6
			20	56
			30	27
			51	7
58051	AN960-516		16	5
			20	46
			34	4
88044	AN960-616	5310-00-167-0821	13	23
			14	2
			15	19
			20	24
			20	32
			35	10
			51	10
88044	AN960-8	5310-00-515-8058	22	7
88044	AN960-816	5310-00-167-0823	20	7

## CROSS-REFERENCE INDEXES

## PART NUMBER INDEX

CAGEC	PART NUMBER	STOCK NUMBER	FIG.	ITEM
80205	AN970-4	5310-00-167-0766	51	4
58536	A52484-1	4730-00-595-0083	13	1
			13	28
			14	11
			14	13
			16	8
			16	9
03743	BL50	5975-00-152-1075	2	29
03743	BL75	5975-00-642-7261	3	29
80204	B1821BHO38C125N	5305-00-068-0511	28	11
80204	B1821BH025C088N	5305-00-071-2505	20	66
			51	5
80204	B1821BH031C075N	5306-00-226-4825	28	13
			34	3
			35	8
80204	B1821BH031C225N	5306-00-226-4834	35	9
80204	B1821BH038C075D	5305-00-115-9526	14	4
			29	20
80204	B1821BH038C175N	5305-00-821-3869	35	3
98441	CL-13	5340-01-395-2166	14	3
56644	CM8SZ	3120-01-394-7284	20	5
11805	CR3213-6-06		20	62
05693	CR3213-8-08	5320-01-393-0842	20	35
52793	CW7435-57C	5310-00-820-6653	12	17
56988	C243	5360-01-388-5783	13	31
			15	23
84256	C8		30	34
4J564	DT318	6110-01-465-7511	2	11
98441	F273017B-6-8-6-6		14	5
	B			
89016	F36237-20	5305-00-054-6654	6	13
76257	G-209-A-5/8	4030-01-416-9994	50	8
60038	HM212049	3110-00-293-8998	17	9

## CROSS-REFERENCE INDEXES

## PART NUMBER INDEX

CAGEC	PART NUMBER	STOCK NUMBER	FIG.	ITEM
81718	H2525M	5310-00-637-9541	28	10
			29	19
30780	H3-62-T8-659		30	2
			49	3
30780	H3-63-T8-659		30	24
			49	13
97111	H3-65M	5340-01-356-5057	30	1
			49	7
97111	H3-66M	5340-01-307-4395	49	12
75665	L-090/095		28	8
75665	L-095-1/2		28	9
15819	LC1.37X5.00	5340-01-394-0005	23	5
75665	L095-3-4		28	7
06383	MLT4H-LP	5975-01-356-6962	27	14
06383	MLT6H-LP		27	14
96906	MS15795-805	5310-00-722-5998	1	6
			3	13
			6	10
96906	MS15795-807	5310-00-880-5978	5	15
96906	MS15795-810	5310-00-582-5677	25	5
96906	MS15795-814	5310-00-773-7618	20	51
			21	4
96906	MS15795-818	5310-00-767-9425	23	7
96906	MS15795-835	5310-00-902-0423	20	38
96906	MS15795-852	5310-01-304-8733	1	22
			3	31
			5	32
			26	2
96906	MS20995C20	9505-00-221-2650	BULK	1
96906	MS20995C20-12IN		30	38
96906	MS21044-N08	5310-00-811-3494	22	6
96906	MS21044-N8	5310-00-877-5795	20	8

## CROSS-REFERENCE INDEXES

## PART NUMBER INDEX

CAGEC	PART NUMBER	STOCK NUMBER	FIG.	ITEM
96906	MS21044C06	5310-00-982-6813	1	7
			3	14
			6	11
96906	MS21044C08	5310-00-982-6814	5	16
96906	MS21044C3	5310-00-208-9255	2	30
			4	11
			5	29
			30	35
			30	35
96906	MS21044C4	5310-00-889-2589	1	21
			3	30
			5	31
			26	5
96906	MS21083-C4	5310-00-897-6145	26	1
96906	MS21245-8	5310-00-449-2376	20	67
96906	MS21919WDG24	5340-00-200-3045	30	46
96906	MS21919WDG40	5340-00-531-6857	30	30
96906	MS21919WDG7	5340-00-200-8559	2	32
96906	MS24523-22	5930-00-683-1628	54A	3
80205	MS24629-36	5305-00-855-0960	9	7
			11	3
80205	MS24629-57	5305-00-052-6921	30	26
96906	MS24665-283	5315-00-842-3044	9	24
96906	MS24665-285	5315-01-359-1451	9	26
96906	MS24665-351	5315-00-839-5821	33	7
96906	MS24665-495	5315-00-234-1664	24	8
			33	6
96906	MS24665-624	5315-00-059-0217	33	3
			50	16
96906	MS24665-688	5315-00-234-1673	20	37
96906	MS24693-95	5305-01-412-0890	54A	13
96906	MS27144-1	5935-00-167-7775	4	3
			5	22

## CROSS-REFERENCE INDEXES

## PART NUMBER INDEX

CAGEC	PART NUMBER	STOCK NUMBER	FIG.	ITEM
96906	MS27144-2	5935-00-115-2307	5	7
			6	4
96906	MS27183-10	5310-00-809-4058	54A	9
96906	MS27183-14	5310-00-080-6004	20	65
96906	MS27183-41	5310-00-765-3197	2	4
96906	MS27183-50	5310-00-285-8124	7	7
96906	MS27183-8	5310-00-809-8546	2	6
96906	MS28778-6	5331-00-804-5695	30	17
			30	17
96906	MS28778-8	5331-00-808-0794	30	3
			49	4
			49	14
96906	MS3367-1-9	5975-00-074-2072	1	14
			2	25
			3	22
96906	MS3367-3-0	5975-00-985-6630	30	37
			30	37
96906	MS35206-242	5305-00-889-3002	2	3
96906	MS35206-247	5305-00-984-6195	22	9
96906	MS35206-267	5305-00-984-6214	2	5
96906	MS35333-71	5310-00-616-3555	6	9
96906	MS35333-72	5310-00-543-2739	5	13
96906	MS35333-73	5310-00-543-5933	4	9
			5	27
96906	MS35335-30	5310-00-209-0788	1	16
			3	26
96906	MS35338-42	5310-00-045-3299	9	20
			20	17
			50	20
96906	MS35338-43	5310-00-045-3296	15	14
96906	MS35338-44	5310-00-582-5965	1	12
			2	17
			3	23

## CROSS-REFERENCE INDEXES

## PART NUMBER INDEX

CAGEC	PART NUMBER	STOCK NUMBER	FIG.	ITEM
96906	MS35338-45	5310-00-407-9566	28	12
96906	MS35338-48	5310-00-584-5272	22	2
96906	MS35338-63		17	3
96906	MS35387-1	9905-00-205-2795	26	7
96906	MS35387-2	9905-00-202-3639	26	3
96906	MS35649-205	5310-00-934-9764	2	7
96906	MS35649-2252	5310-00-997-1888	1	13
			2	18
			3	24
96906	MS35649-264	5310-00-934-9761	3	25
96906	MS35692-57	5310-00-850-6881	9	6
96906	MS51335-2	2540-00-835-9039	22	1
96906	MS51412-25	5310-00-044-6477	20	61
			34	6
			35	7
96906	MS51412-8	5310-01-267-1685	24	1
			33	8
96906	MS51527A8	4730-00-822-5609	30	9
			30	9
96906	MS51861-34	5305-00-058-1082	9	21
			20	16
			50	19
96906	MS51922-1	5310-00-088-1251	51	8
			54A	8
96906	MS51922-17	5310-00-087-4652	15	20
			20	64
			21	3
			35	11
			51	9
96906	MS51922-17A	5310-00-087-4652	13	24
			14	1
			20	23
			20	33

## CROSS-REFERENCE INDEXES

## PART NUMBER INDEX

CAGEC	PART NUMBER	STOCK NUMBER	FIG.	ITEM
96906	MS51957-124	5305-00-411-0682	3	27
96906	MS51957-31	5305-00-054-6655	6	12
96906	MS51957-32	5305-00-054-6656	1	18
			3	28
96906	MS51957-35	5305-00-054-6659	1	17
96906	MS51957-46	5305-00-054-6671	5	14
96906	MS51957-65	5305-00-050-9231	15	15
96906	MS51958-64	5305-00-059-3660	5	26
			30	32
96906	MS51958-65	5305-00-059-3661	2	33
			4	8
			30	47
96906	MS51958-80	5305-00-059-3676	26	4
96906	MS51958-81	5305-00-059-3677	26	6
96906	MS51958-82	5305-00-059-5432	26	4
96906	MS51967-8	5310-00-732-0558	2	27
80205	MS51975-17	5305-00-881-0705	20	2
80205	MS51975-55	5305-00-858-5558	20	15
96906	MS53007-1	9905-00-999-7370	27	9
96906	MS75021-1	5935-00-846-3883	2	16
			3	19
96906	MS75021-2	5935-00-846-3884	1	9
96906	MS90724-7	5310-00-144-8453	2	8
96906	MS90725-109	5305-00-044-4153	22	3
96906	MS90725-122		23	1
96906	MS90725-3	5305-00-068-0500	2	15
96906	MS90725-33	5306-00-225-8498	20	50
96906	MS90725-34	5306-00-225-8499	16	6
			34	8
96906	MS90725-5	5305-00-068-0501	1	11
			3	21
96906	MS90725-6	5305-00-068-0502	2	12
			3	15

## CROSS-REFERENCE INDEXES

## PART NUMBER INDEX

CAGEC	PART NUMBER	STOCK NUMBER	FIG.	ITEM
96906	MS90725-60	5305-00-269-3211	13	22
			15	18
			20	45
			20	57
			21	1
96906	MS90725-67	5305-00-269-3217	20	31
96906	MS90725-69	5305-00-269-3219	20	53
96906	MS90728=8	5305-00-225-3843	7	8
			25	2
96906	MS9352-14	5340-01-213-5535	3	32
81349	M45913/1-10CG5C	5310-00-269-4040	20	9
81349	M45913/1-4CG5C	5310-00-088-1251	7	5
			20	55
			25	4
81349	M45913/1-5CG5C	5310-00-984-3806	16	7
			20	47
			34	7
			35	6
81349	M45913/1-8CG5C	5310-00-225-6993	23	6
			24	2
81349	M45913/2-12FG5C	5310-00-832-9719	24	5
45722	NO. 4-3/16	5305-01-417-1545	27	23
			50	4
45722	NO. 4-5/16	5305-01-417-1546	27	22
			49	9
45722	NO. 4-5/16	5305-01-417-1546	50	7
97424	N226P13-1	5310-00-934-9761	1	15
31013	OC60E1	2815-01-393-9846	35	1
59838	PBS-10-5-D10	6680-01-393-4023	34	2
18876	PMS90727001-06	5306-00-068-0513	17	2
21439	POCI-10-N-O-XX	4820-01-418-0937	31	2
			54	36
7Z588	QS200M80S		28	4



## CROSS-REFERENCE INDEXES

## PART NUMBER INDEX

CAGEC	PART NUMBER	STOCK NUMBER	FIG.	ITEM
81860	R18733-6	5310-01-393-6783	35	5
76257	S-247-3/8	3040-01-393-5275	9	25
81992	SHC-1037	5975-01-207-0229	2	24
29260	SVE12	4820-01-394-0480	29	12
29260	SVW1BA1	4820-01-393-6363	29	15
50019	S1990	4730-00-595-3108	16	2
50153	T-110M11		15	26
50153	T-211M11		15	27
27783	TR573	2640-00-555-2824	18	4
79934	TR78A	2640-01-093-2842	18	4
13556	004-00293-1		1	5
			3	12
13556	007-00098-3	5940-01-346-1336	1	4
			3	11
31013	01023-50610	5306-01-393-4861	48	1
31013	01053-50620	5305-01-393-4850	41	9
31013	01153-50818	5306-01-393-4849	41	5
31013	01513-50814	5307-01-393-4851	43	5
31013	01513-50855	5307-01-393-4854	39	7
31013	01754-50610	5306-01-393-4863	44	5
			47	11
31013	01754-50612	5306-01-393-4857	42	4
			44	1
			47	5
31013	01754-50620	5306-01-393-7080	39	8
			45	3
			46	4
31013	01754-50630	5306-01-393-4853	42	3
31013	01754-50650	5306-01-393-4862	37	4
31013	01754-50825	5305-01-393-4859	37	3
31013	01754-50835	5305-01-393-4859	47	10
31013	01754-50855	5306-01-393-4864	37	5

## CROSS-REFERENCE INDEXES

## PART NUMBER INDEX

CAGEC	PART NUMBER	STOCK NUMBER	FIG.	ITEM
31013	01754-60816	5306-01-393-4847	39	12
			40	9
			41	6
			43	4
			46	2
S4532	02114-50080	5310-01-320-7060	43	7
			47	7
31013	02156-50080	5310-01-393-6781	39	5
31013	04015-50060	5310-01-393-6776	41	8
S4532	04512-50080	5310-01-321-3477	47	8
31013	04724-00120	5331-01-393-5639	38	8
31013	04724-00120	5331-01-393-5639	41	16
31013	04811-00180	5331-01-393-2861	37	8
			38	5
S4532	04811-40140	5331-01-320-9556	38	9
52793	05-047543		12	18
52793	05-047571	2590-01-428-1697	22	12
31013	05712-00520	5315-01-393-1316	36	1
31013	06331-35012	5365-01-393-1858	41	17
29260	071700117	3040-01-465-1259	54	27
30780	1-2SHPB	4730-00-011-3176	13	17
			16	12
31013	1G131-51010		39	10
31013	1G131-52110		39	11
31013	1G141-53000		39	1
0NTD7	1R11-094	2510-01-393-6526	24	3
88763	101A-E	4730-01-422-4160	13	14
31013	10244-4232-0	4730-01-359-4773	39	2
31013	11151-4144-0	5325-01-393-8382	41	1
31013	11151-7732-0	5365-01-393-1864	41	7
88763	113RB-E3	4730-01-422-4155	13	25
31013	11420-0480-3	5340-01-393-2871	42	1
31013	11420-1101-0	2940-01-393-7532	40	1

## CROSS-REFERENCE INDEXES

## PART NUMBER INDEX

CAGEC	PART NUMBER	STOCK NUMBER	FIG.	ITEM
31013	11420-1115-0		40	2
31013	11420-1116-0		40	5
31013	11420-1118-0	2940-01-393-5248	40	4
31013	11420-1223-0	5330-01-393-2864	43	6
31013	11420-1452-0	5330-01-393-3744	37	7
31013	11420-2337-0	5310-01-393-6782	36	3
31013	11420-3308-2	5342-01-393-2869	37	9
31013	11420-3640-2	6680-01-393-4020	38	6
31013	11420-3701-0		38	3
31013	11420-3715-0	4710-01-393-5241	38	2
31013	11420-3717-0	4710-01-393-5245	38	4
31013	11420-4101-0	2910-01-393-5249	41	10
31013	11420-4103-0	5342-01-393-2872	41	11
31013	11420-4113-2	5340-01-393-2870	41	3
31013	11420-4137-0	5310-01-393-6780	41	4
31013	11420-4141-0	5340-01-393-2860	41	2
31013	11420-4171-0	6680-01-393-4021	41	14
31013	11420-4201-0	4710-01-393-5867	41	19
31013	11420-4250-0	4710-01-393-5244	39	3
31013	11420-43012	2910-01-393-5254	41	20
31013	11420-5345-0	5340-01-393-2859	39	6
31013	11420-5362-0	5331-01-393-2862	39	15
31013	11420-5371-0	4710-01-393-5872	39	14
31013	11420-5385-0	5340-01-393-6308	39	13
31013	11420-6301-0	2920-01-393-4550	47	9
31013	11420-6360-2	5340-01-393-6310	47	2
31013	11420-6460-0	6110-01-431-9890	46	3
31013	11420-6461-0	5340-01-393-2868	46	1
31013	11420-6556-0	6150-01-393-5104	48	3
31013	11420-6575-0	6150-01-393-5115	47	6
31013	11420-6703-0	2815-01-393-7541	36	2
31013	11420-6705-0	2920-01-393-5268	45	2
31013	11420-6768-0	5325-01-438-9353	45	1

## CROSS-REFERENCE INDEXES

## PART NUMBER INDEX

CAGEC	PART NUMBER	STOCK NUMBER	FIG.	ITEM
31013	11420-7408-2	5340-01-393-2873	44	3
31013	11420-7449-0	5340-01-393-2865	44	2
31013	11420-7537-0	5340-01-393-2866	44	4
31013	11420-8715-0	9905-01-395-0889	42	5
31013	11420-8745-0		40	6
31013	11420-8752-0	9905-01-395-0888	47	3
31013	11420-8755-0	9905-01-395-2087	42	2
31013	11420-9101-0	5305-01-393-4860	43	2
31013	11520-1205-0	2990-01-393-5247	43	3
31013	11520-1270-0	5340-01-393-2863	43	1
31013	11520-1450-0	5340-01-393-2876	37	6
31013	11520-8821-0	9905-01-395-0887	41	15
31013	11521-3308-0	5342-01-393-6306	38	11
98343	11541	4730-01-385-6972	13	30
			15	24
08806	1157	6240-00-889-1799	5	5
31013	11811-0175-0	1730-01-419-6112	37	2
31013	11811-3703-0	5340-01-420-4519	37	1
19200	12009209		18	2
30780	1202P4-4		15	5
89346	120401	4730-00-810-0059	15	12
19207	12258212	6220-01-088-5915	5	17
88763	123A-ED	4730-01-422-5721	13	15
4J564	12360744		2	2
19207	12368919	5340-01-429-9351	2	10
31013	12752-1117-0	5331-01-393-2874	40	3
31013	12752-1133-0	5305-01-393-4856	40	8
30327	129-B-08X24	4730-00-407-0571	14	6
97403	13211E9018-12	4730-00-225-0699	30	22
97403	13229E0887-2	5340-01-307-4395	30	23
04NP3	138-864-554	2610-01-465-5823	18	1
04NP3	138382553	2610-01-281-0675	18	1
31013	13901-3375-0	5365-01-393-1859	38	7

## CROSS-REFERENCE INDEXES

## PART NUMBER INDEX

CAGEC	PART NUMBER	STOCK NUMBER	FIG.	ITEM
31013	13901-4135-0	2910-01-393-5246	41	12
31013	13965-1151-0	5330-01-393-5638	40	10
31013	14301-4236-0	4730-01-394-3739	41	13
31013	14351-1134-0	5310-01-393-6779	40	7
31013	14911-3201-0	2910-01-393-7530	38	10
S4532	14911-4275-0	4730-01-359-4772	41	18
31013	14941-0557-0	4730-01-393-2164	38	1
98343	1509	5330-00-172-1919	13	2
			13	29
			14	12
			14	14
98343	1512-1-15	5925-00-900-1903	2	9
61349	151469	6685-01-373-7976	55	2
31013	15241-6758-0	5340-01-395-0121	47	12
31013	15241-6758-0	5340-01-395-0121	48	2
31013	15261-2336-0	5310-01-393-6785	36	4
31013	15471-9569-0	4730-01-393-2162	39	9
31013	15841-53620	5331-01-431-3621	39	15
31013	16241-6551-0	2920-01-393-4547	48	4
21439	16282-219		9	10
			11	11
31013	19077-53650	5330-01-431-3620	39	16
56988	192		30	33
93061	207ACBH-6	4730-00-511-1677	13	4
93061	207ACBH-8	4730-00-407-0571	16	13
01276	2070-6-6S	4730-01-195-7331	30	15
01276	2082-6B	4730-00-427-5121	13	32
			14	7
			15	30
96652	21-09	5315-01-171-0750	20	21
93061	216P8-6	4730-00-287-4852	13	3
			16	14
93061	2200P8-8	4730-01-289-9536	13	13

## CROSS-REFERENCE INDEXES

## PART NUMBER INDEX

CAGEC	PART NUMBER	STOCK NUMBER	FIG.	ITEM
93061	2202P-6-6	4730-00-278-4822	13	18
			15	21
93061	2203P-6	4730-00-277-7331	16	18
30780	2214-6-6		15	3
93061	2224P-2	4730-00-595-0251	15	10
93061	2225P-6	4730-00-469-7797	13	5
10001	2256784PC3	4730-00-222-0135	55	1
70763	2300622		28	3
22337	255-262	2610-01-292-3009	18	1
28527	2616950G001	5310-00-615-1556	2	31
			4	10
			5	28
			30	49
98441	2730101-6-8-6B-6		14	9
	4			
73195	27404N	2530-01-329-7523	17	16
30780	3-4FFB	4730-00-068-8656	13	12
30780	3/8X3/8-FF-B	4730-00-249-9714	13	10
13548	30200R	6220-01-085-3391	6	8
93061	3121-4-10	5340-01-417-7278	30	28
31013	32240-3449-0	5340-01-393-6307	39	4
F0022	327		54A	6
54641	336	4730-00-287-3281	15	13
80201	35086	5330-01-464-9956	17	13
83330	367-8430-0931-50	6210-01-218-4050	54A	7
	3			
83330	367-8430-0932-50	6210-01-003-4277	54A	5
	3			
31013	37410-5515-0	5930-01-393-4710	47	1
31013	37410-5911-0	2920-01-393-5869	47	4
00303	382	6240-00-965-1381	54A	4
91047	445205	2610-00-029-0563	18	3

## CROSS-REFERENCE INDEXES

## PART NUMBER INDEX

CAGEC	PART NUMBER	STOCK NUMBER	FIG.	ITEM
98441	451AR-05-06-6-6- 4-40	4720-01-393-4575	30	7
98441	451AR-05-06-6-6- 4-92	4720-01-393-4577	30	10
98441	451AR-05-06-6-6- 4-96	4720-01-393-5277	30	19
98441	451AR-3-06-6-6-4 -129	4720-01-393-5278	30	14
98441	451AR-39-06-6-6- 4-78	4720-01-393-4576	30	13
52793	48139	4730-01-429-1321	9	13
81860	505-1LS	5342-01-393-2877	35	4
26935	506.5G2		23	3
80201	5062	5330-00-526-5783	28	2
0NTD7	578-92-9-122	4820-01-421-8062	24	4
81343	6-6 070221CA	4730-00-618-5372	30	6
			30	6
90661	6-8C5XS		30	11
90661	6-8F5XS		30	5
			30	5
30780	6CC5XS		30	16
30780	6R6BXS	4730-00-618-5381	30	12
83259	600-015-1-4	5330-00-171-8363	25	3
29260	660280004	4820-01-419-4120	52	1
29260	660401003	2530-01-393-5878	29	2
80204	67	6240-00-155-8717	4	7
			5	20
0KZG3	68150		5	6
76257	710-0107	5310-01-393-6777	9	15
19207	7388820	2530-00-603-5768	17	16
19207	7389061	2530-00-738-9061	17	18
19207	7389493		17	17
61424	741590-BLUE	4720-01-393-5250	14	15

## CROSS-REFERENCE INDEXES

## PART NUMBER INDEX

CAGEC	PART NUMBER	STOCK NUMBER	FIG.	ITEM
93061	741590-RED	4720-01-393-5252	14	10
16528	7731428	5975-01-321-7295	1	10
			2	14
			3	20
98343	782	5935-01-141-0877	2	13
96652	79-07	3990-01-418-8755	9	19
			20	18
			22	8
96652	79-08	3990-01-418-8756	20	27
			50	21
30780	8-6-F5G5-S	4730-00-933-0727	30	18
30780	8C6XS		30	40
21439	8D000152-4		32	15
21439	8D00044-1	5120-01-393-2582	7	2
21439	8D00051-10		31	3
21439	8D00051-11		31	13
21439	8D00051-12		31	8
21439	8D00051-13		31	6
21439	8D00051-14		31	7
21439	8D00051-15		31	4
21439	8D00051-16		31	5
21439	8D00051-17		KITS	
21439	8D00051-4		31	14
21439	8D00051-5		31	10
21439	8D00051-6		31	12
21439	8D00051-7	3040-01-466-0005	31	11
21439	8D00051-8		31	9
21439	8D00051-9		31	15
21439	8D00052-1	4720-01-418-5287	30	39
21439	8D00052-11	4720-01-393-4581	30	41
21439	8D00052-12	4720-01-393-5880	30	42
21439	8D00052-2	4720-01-393-4572	30	8
			30	8



## CROSS-REFERENCE INDEXES

## PART NUMBER INDEX

CAGEC	PART NUMBER	STOCK NUMBER	FIG.	ITEM
21439	8D00052-3	4720-01-419-7872	30	20
21439	8D00052-4	4720-01-406-1934	49	6
			49	11
21439	8D00052-8	4720-01-393-5884	30	44
21439	8D00052-9	4720-01-393-5886	30	43
21439	8D00059-1	2510-01-393-5259	24	10
21439	8D00060-1	5315-01-392-9397	20	20
			33	1
21439	8D00060-2	5315-01-392-9394	33	4
21439	8D00060-3	5315-01-392-9391	33	9
21439	8D00060-4	5315-01-392-8539	24	9
21439	8D00060-5	5315-01-392-9393	24	11
21439	8D00060-6	5315-01-392-8542	24	11
21439	8D00060-7	5315-01-392-9395	20	40
0AYE7	8D00060-8	5315-01-416-8905	50	23
21439	8D00061-1	4710-01-394-4780	20	30
21439	8D00061-6	5340-01-432-4862	20	34
21439	8D00062-10	9905-01-394-9849	27	17
21439	8D00062-11	9905-01-420-2785	50	2
21439	8D00062-12	9905-01-421-6243	50	3
21439	8D00062-13	9905-01-395-2712	27	16
21439	8D00062-14	9905-01-394-9851	27	20
21439	8D00062-15	9905-01-395-2088	27	6
21439	8D00062-16	9905-01-394-9853	27	5
21439	8D00062-17	9905-01-395-4077	27	19
21439	8D00062-18	9905-01-394-9859	27	21
21439	8D00062-19	9905-01-395-2713	27	13
21439	8D00062-20	9905-01-395-2089	27	1
21439	8D00062-21	9905-01-421-1714	27	7
21439	8D00062-22	9905-01-421-0349	50	5
21439	8D00062-23	9905-01-421-2970	50	6
21439	8D00062-24	9905-01-421-1715	49	8
21439	8D00062-25	7690-01-431-8641	27	21

## CROSS-REFERENCE INDEXES

## PART NUMBER INDEX

CAGEC	PART NUMBER	STOCK NUMBER	FIG.	ITEM
21439	8D00062-26	7690-01-431-8642	27	15
21439	8D00062-27	7690-01-431-8639	50	26
21439	8D00062-28	7690-01-431-8645	27	7
21439	8D00062-6	9905-01-394-9841	27	4
21439	8D00062-7	9905-01-394-9843	27	3
21439	8D00062-8	9905-01-394-9845	27	2
21439	8D00062-9	9905-01-394-9856	27	18
21439	8D00063-1	4720-01-428-9691	15	2
21439	8D00063-3	4720-01-428-9692	14	9
			15	29
21439	8D00063-7	4720-01-406-1924	14	16
21439	8D00064-10	4720-01-393-4580	16	16
21439	8D00064-12	4710-01-406-1921	16	17
21439	8D00064-13		16	19
21439	8D00064-14	4720-01-393-4578	15	4
21439	8D00064-15	4720-01-393-4579	15	8
21439	8D00064-17	4710-01-406-1927	16	10
21439	8D00064-18	4710-01-406-1928	16	3
21439	8D00064-19	4710-01-406-1925	15	16
21439	8D00064-20	4710-01-406-1922	15	9
21439	8D00064-21		13	7
21439	8D00064-22	4720-01-422-7846	13	6
21439	8D00064-23	4720-01-466-2736	13	8
21439	8D00064-24		13	33
21439	8D00064-3	4710-01-393-7540	13	21
21439	8D00064-4		13	19
21439	8D00064-8		15	6
21439	8D00065-13		30	29
			30	29
21439	8D00066-1	6150-01-393-5112	8	1
21439	8D00066-10	6150-01-393-6171	1	8
21439	8D00066-11	6150-01-393-6172	3	18
21439	8D00066-12	6150-01-393-6208	3	17

## CROSS-REFERENCE INDEXES

## PART NUMBER INDEX

CAGEC	PART NUMBER	STOCK NUMBER	FIG.	ITEM
21439	8D00066-2	6150-01-393-5113	8	3
21439	8D00066-3	6150-01-393-5118	8	2
21439	8D00066-4	6150-01-393-5114	2	23
21439	8D00066-5	6150-01-393-5108	2	21
21439	8D00066-6	6150-01-393-5107	2	22
21439	8D00066-7	6150-01-393-5109	3	6
21439	8D00066-8	6150-01-393-5110	3	5
21439	8D00066-9	6150-01-393-6173	3	7
21439	8D00067-1	6220-01-393-5111	21	2
21439	8D00068-1	5340-01-417-7277	21	5
21439	8D00068-2	5340-01-393-7082	21	5
21439	8D00070-1	4010-01-406-0511	9	18
21439	8D00073-1	2510-01-393-2666	20	1
21439	8D00073-2	2590-01-393-5873	20	3
21439	8D00077-41	5315-01-424-7838	20	41
21439	8D00079-1	4710-01-394-4779	20	58
21439	8D00079-2	5340-01-393-6786	20	58
21439	8D00080-1	3040-01-393-5240	20	42
21439	8D00080-2	3040-01-393-5243	20	42
21439	8D00081-1	2590-01-393-5871	20	13
21439	8D00082-18	5307-01-393-5642	9	23
21439	8D00082-19	5307-01-393-3742	9	17
21439	8D00087-1	2540-01-393-7972	23	4
21439	8D00088-1	5340-01-393-1315	23	2
21439	8D00091-1	2540-01-393-7544	9	16
21439	8D00093-1	2530-01-393-5169	9	1
21439	8D00095-1	4320-01-393-9843	28	1
21439	8D00096-1	3040-01-393-7533	28	5
21439	8D00097-1	2530-01-393-5877	13	26
21439	8D00097-2	2530-01-393-5256	15	17
21439	8D00101-1	6110-01-393-8898	1	1
21439	8D00102-1	2510-01-393-5168	20	52
21439	8D00102-2	2510-01-393-5091	20	68

## CROSS-REFERENCE INDEXES

## PART NUMBER INDEX

CAGEC	PART NUMBER	STOCK NUMBER	FIG.	ITEM
21439	8D00105-1	6220-01-393-2332	5	2
21439	8D00105-13	7690-01-418-0407	4	2
			5	11
			5	21
			6	3
21439	8D00105-14	9905-01-423-2596	5	12
21439	8D00105-15	9905-01-423-2590	5	12
21439	8D00105-2	6220-01-393-2331	5	19
21439	8D00105-3	6220-01-393-4024	4	1
21439	8D00105-4	6220-01-417-7414	6	1
21439	8D00105-5	6220-01-393-2335	5	2
21439	8D00106-1	2510-01-393-5868	20	39
21439	8D00107-1	2510-01-426-2443	20	12
21439	8D00109-1	4820-01-393-5276	29	1
21439	8D00109-14	4820-01-431-2389	29	1
21439	8D00110-33		20	6
21439	8D00112-1		2	1
21439	8D00114-1	5140-01-394-2021	25	1
21439	8D00115-1	4320-01-393-9844	34	1
21439	8D00119-1	3040-01-393-5251	20	42
21439	8D00119-2	3040-01-393-5258	20	42
21439	8D00121-1	4820-01-393-4553	13	20
			15	7
21439	8D00121-10	2530-01-393-4548	13	11
21439	8D00121-11	4820-01-393-4549	13	9
21439	8D00121-12	4820-01-393-5255	15	1
21439	8D00121-2	4820-01-393-4552	16	15
21439	8D00121-25	4820-01-423-4847	16	11
21439	8D00121-5	2530-01-393-7535	13	16
			16	1
21439	8D00121-6	4820-01-393-4555	13	27
			15	22
21439	8D00121-7	5340-01-393-7079	20	48

## CROSS-REFERENCE INDEXES

## PART NUMBER INDEX

CAGEC	PART NUMBER	STOCK NUMBER	FIG.	ITEM
21439	8D00121-8	2530-01-422-7473	16	4
21439	8D00121-9	4820-01-393-4551	15	11
21439	8D00123-31R		7	1
21439	8D00123-38B	6150-01-406-2906	7	3
21439	8D00123-42B	6140-01-466-5416	7	3
21439	8D00123-48R	6140-01-406-8993	7	1
21439	8D00125-1	2510-01-393-5870	20	1
21439	8D00125-2	2590-01-393-7531	20	3
21439	8D00125-3	5340-01-393-5650	20	54
21439	8D00125-4		20	63
21439	8D00129-1	6110-01-393-8897	3	1
21439	8D00129-6	5935-01-394-2106	3	16
21439	8D00130-1	2530-01-393-5875	11	1
21439	8D00131-1	2540-01-393-7534	22	4
21439	8D00133-1	5340-01-393-1860	35	2
21439	8D00135-1	4940-01-393-5874	3	2
21439	8D00138-1		5	1
21439	8D00138-2		5	1
21439	8D00139-1	6220-01-393-4019	5	18
21439	8D00139-2	6220-01-393-2333	5	18
21439	8D00140-1	2510-01-393-5744	20	39
21439	8D00141-1	2510-01-393-5087	20	12
21439	8D00143-1	3010-01-393-2160	28	6
21439	8D00145-1	3040-01-393-7529	31	1
21439	8D00146-1	3040-01-393-7983	32	1
21439	8D00151-1	5306-01-393-3741	9	12
			11	6
21439	8D00151-2	5310-01-393-7081	9	9
			11	12
21439	8D00152-11		32	16
21439	8D00152-12		32	2
21439	8D00152-13		32	7
21439	8D00152-15	5365-01-466-9524	32	6

## CROSS-REFERENCE INDEXES

## PART NUMBER INDEX

CAGEC	PART NUMBER	STOCK NUMBER	FIG.	ITEM
21439	8D00152-16		32	5
21439	8D00152-17		32	3
21439	8D00152-18		32	4
21439	8D00152-19		32	12
21439	8D00152-20		32	8
21439	8D00152-21		KITS	
21439	8D00152-22		32	10
21439	8D00152-23		32	9
21439	8D00152-6		32	14
21439	8D00152-7		32	13
21439	8D00152-8	3040-01-466-0004	32	11
21439	8D00186-1	5975-01-418-6041	1	3
21439	8D00191-1	3040-01-417-9823	53	1
21439	8D00193-1	3040-01-420-9855	54	1
21439	8D00194-1	3950-01-418-0930	50	1
21439	8D00195-10	2530-01-393-2675	10	1
21439	8D00195-12	2530-01-393-2672	10	1
21439	8D00195-16	5340-01-393-2878	10	2
21439	8D00195-18	5365-01-393-0840	10	3
21439	8D00195-19		19	8
21439	8D00195-20	2530-01-393-7545	19	9
21439	8D00195-21	5310-01-393-5644	19	13
21439	8D00195-22		19	14
21439	8D00195-23	5310-01-393-5649	19	15
21439	8D00195-24		19	16
21439	8D00195-25	2530-01-393-5270	10	5
21439	8D00195-26	5315-01-393-0837	10	4
21439	8D00195-29	5310-01-393-5646	12	16
21439	8D00195-31		17	1
21439	8D00195-35	5331-01-418-0621	17	5
21439	8D00195-36	5340-01-393-2609	17	4
21439	8D00195-37	5310-01-394-2370	17	11
21439	8D00195-38	5310-01-393-5647	17	8

## CROSS-REFERENCE INDEXES

## PART NUMBER INDEX

CAGEC	PART NUMBER	STOCK NUMBER	FIG.	ITEM
21439	8D00195-39	5310-01-393-5648	17	7
21439	8D00195-40	5310-01-421-9481	17	6
21439	8D00195-41		17	1
21439	8D00195-43	5310-01-393-5653	17	11
1NHH8	8D00195-44	5315-01-473-2046	19	5
21439	8D00195-45	5310-01-393-6313	19	1
21439	8D00195-46	5306-01-430-3411	19	2
21439	8D00195-53	2530-01-393-5271	17	12
21439	8D00195-54	2530-01-393-7543	17	15
21439	8D00195-55	3110-01-394-7718	17	10
21439	8D00195-56	5307-01-393-5652	17	14
21439	8D00195-57	5307-01-393-6314	17	14
21439	8D00195-58	5315-01-393-1318	19	3
21439	8D00195-59		19	4
21439	8D00195-60		9	27
21439	8D00195-66	4730-01-421-6441	19	7
			22	11
			22	15
21439	8D00195-7	2530-01-393-5173	19	17
21439	8D00195-70	2590-01-428-1697	19	6
			22	14
21439	8D00195-71	5325-01-317-4273	22	13
21439	8D00195-72	5310-01-419-5660	19	10
21439	8D00195-73		19	11
21439	8D00195-74		19	12
21439	8D00196-10	4820-01-393-5274	29	3
21439	8D00196-15		29	10
21439	8D00196-16		29	11
21439	8D00196-34		29	6
21439	8D00196-36		29	9
21439	8D00196-37		29	16
21439	8D00196-38		29	8
21439	8D00196-39		29	17

## CROSS-REFERENCE INDEXES

## PART NUMBER INDEX

CAGEC	PART NUMBER	STOCK NUMBER	FIG.	ITEM
21439	8D00196-40		29	5
21439	8D00196-41		29	18
21439	8D00196-42		29	7
21439	8D00196-43		29	4
21439	8D00196-44	4820-01-394-0541	29	13
21439	8D00196-72	4820-01-419-7040	29	14
21439	8D00196-86	5330-01-393-4783	KITS	
21439	8D00196-89	3040-01-393-7546	KITS	
21439	8D00196-94	5340-01-432-2903	29	16
21439	8D00197-10		12	1
21439	8D00197-11	2530-01-393-7163	14	8
21439	8D00197-12	5310-01-431-4074	15	28
21439	8D00197-13	2530-01-393-5876	12	12
21439	8D00197-14	5340-01-393-6309	12	15
21439	8D00197-15	2530-01-393-5879	12	2
21439	8D00197-16	5340-01-393-6784	12	6
21439	8D00197-19	5340-01-393-6315	12	5
21439	8D00197-20	5310-01-393-6316	12	4
21439	8D00197-21	5306-01-393-5641	12	3
21439	8D00197-30	2530-01-393-5881	12	10
21439	8D00197-31	5310-01-393-6312	12	13
21439	8D00197-32	5305-01-393-5645	12	14
21439	8D00197-33	5360-01-393-0839	12	11
21439	8D00197-34		12	1
21439	8D00197-35		12	1
21439	8D00197-36	2530-01-393-5279	15	25
21439	8D00197-37	4030-01-393-0836	12	7
21439	8D00197-38		12	1
21439	8D00197-39	5310-01-393-5643	12	8
21439	8D00197-40	5331-01-393-4866	12	9
21439	8D00198-1		50	24
21439	8D00199-1		50	14
21439	8D00200-1	2590-01-418-5568	50	22



## CROSS-REFERENCE INDEXES

## PART NUMBER INDEX

CAGEC	PART NUMBER	STOCK NUMBER	FIG.	ITEM
21439	8D00201-1	5340-01-426-8784	50	13
21439	8D00202-1	5315-01-419-2308	20	14
21439	8D00202-2	5315-01-394-7521	20	49
21439	8D00202-3	5315-01-394-7523	20	19
21439	8D00202-4	5315-01-394-7522	20	28
21439	8D00202-5	5315-01-416-8903	50	15
21439	8D00202-6	5315-01-428-5920	50	18
21439	8D00203-1	5340-01-393-1862	20	60
21439	8D00204-1	2590-01-393-5273	20	44
21439	8D00205-1	5340-01-393-4865	20	59
21439	8D00207-1	5340-01-393-7083	20	29
21439	8D00207-2	5340-01-393-9366	20	36
21439	8D00208-1	3940-01-418-3504	50	25
21439	8D00209-1	4010-01-417-1547	50	11
21439	8D00209-2	4010-01-405-9922	50	10
21439	8D00209-3	4010-01-417-1548	50	9
21439	8D00212-1	5340-01-417-7276	21	2
21439	8D00214-1	2590-01-406-3526	21	6
21439	8D00215-1	5340-01-393-6788	21	6
21439	8D00217-1	2590-01-422-7462	20	25
21439	8D00220-1	1730-01-406-2585	49	1
21439	8D00220-2	4720-01-406-1936	49	10
21439	8D00220-3	4720-01-406-1935	49	2
21439	8D00222-1	2590-01-418-5571	22	5
21439	8D00223-1	3990-01-421-4290	25	6
21439	8D00226-1	5365-01-416-9992	33	10
			33	10
0EXZ4	8D00227-1	5306-01-417-5740	20	26
0EXZ4	8D00227-2	5306-01-417-8590	51	11
21439	8D00228-1		51	1
21439	8D00228-4	5330-01-431-3107	51	2
21439	8D00228-5	5330-01-431-3100	51	3
21439	8D00229-1	5340-01-417-2485	51	6

## CROSS-REFERENCE INDEXES

## PART NUMBER INDEX

CAGEC	PART NUMBER	STOCK NUMBER	FIG.	ITEM
0EXZ4	8D00229-2	5340-01-417-2483	51	12
21439	8D00231-1	2540-01-418-5567	20	22
21439	8D00232-1	5340-01-419-3838	9	5
			11	2
21439	8D00232-2	5340-01-431-4073	9	3
			11	8
21439	8D00234-10	5340-01-466-3781	54	10
21439	8D00234-11	5325-01-416-9990	54	17
21439	8D00234-12		54	21
21439	8D00234-13	5342-01-426-8904	54	4
21439	8D00234-15	5305-01-417-1542	54	6
21439	8D00234-16		54	5
21439	8D00234-17	5325-01-405-9921	54	9
21439	8D00234-18	5325-01-416-9993	54	18
21439	8D00234-20		54	19
21439	8D00234-21	3040-01-418-1846	54	29
21439	8D00234-22	3040-01-418-3102	54	8
21439	8D00234-23	3040-01-418-3031	54	11
21439	8D00234-24		54	7
21439	8D00234-25		54	20
21439	8D00234-26		54	12
21439	8D00234-27		54	14
21439	8D00234-28		54	33
21439	8D00234-29		54	26
21439	8D00234-30		54	24
			54	25
21439	8D00234-31		54	32
21439	8D00234-32		54	16
21439	8D00234-33		54	15
21439	8D00234-34		54	3
21439	8D00234-35		54	24
21439	8D00234-37	5330-01-408-0885	KITS	
21439	8D00234-38		54	28

## CROSS-REFERENCE INDEXES

## PART NUMBER INDEX

CAGEC	PART NUMBER	STOCK NUMBER	FIG.	ITEM
21439	8D00234-39	4820-01-418-5573	54	35
21439	8D00234-4	3040-01-429-3289	54	30
21439	8D00234-42		54	23
21439	8D00234-44		54	22
21439	8D00234-5		54	2
21439	8D00234-6	3040-01-429-3287	54	13
21439	8D00234-7	3040-01-418-4576	54	34
21439	8D00234-9		54	31
21439	8D00235-10	5310-01-417-1543	53	14
21439	8D00235-11	3040-01-418-3026	53	15
21439	8D00235-15		53	13
21439	8D00235-16		53	10
21439	8D00235-17	3040-01-418-1734	53	11
21439	8D00235-18		53	12
21439	8D00235-20		53	5
21439	8D00235-21		53	8
21439	8D00235-22		53	3
21439	8D00235-23	3040-01-418-4574	53	6
21439	8D00235-24	3040-01-418-1718	53	7
21439	8D00235-25		KITS	
21439	8D00235-26		53	4
21439	8D00235-4	3040-01-418-4572	53	2
21439	8D00235-9		53	9
21439	8D00236-1	5306-01-422-5966	9	2
			11	9
21439	8D00237-1	4730-01-406-1923	9	4
			11	7
21439	8D00281-1	5340-01-421-9482	34	5
21439	8D00298-1	5310-01-429-8520	9	11
			11	10
21439	8D00313-1		11	5
21439	8D00316-1	4010-01-431-3239	9	8
			11	4

## CROSS-REFERENCE INDEXES

## PART NUMBER INDEX

CAGEC	PART NUMBER	STOCK NUMBER	FIG.	ITEM
21439	8D00341-1	5315-01-429-7277	9	22
			20	43
			22	10
21439	8D00346-1	5930-01-467-2945	54A	2
21439	8D00347-1	5340-01-438-1615	54A	10
21439	8D00347-2	5340-01-438-7485	54A	12
21439	8D00350-1	6110-01-466-6395	54A	1
21439	8D00350-6	5340-01-438-7023	54A	11
21439	8D00358-1		30	31
			30	45
21439	8D00359-1		30	48
21439	8D00362-1	6150-01-466-9167	54A	14
21439	8D00373-1		7	4
30780	8F5BX-S	4730-01-156-4835	30	21
			49	5
			49	15
30780	8LHTX-S	4730-00-903-7652	30	4
			30	4
19207	8338561	5935-00-833-8561	4	4
			5	23
19207	8338562	5970-00-833-8562	4	5
			5	9
			5	24
			6	6
			6	6
19207	8338564	5940-00-399-6676	4	6
			5	10
			5	25
			6	7
30327	848-FS-06X06	4730-01-334-5710	30	25
12195	85335		18	1
19207	8724494	5975-00-660-5962	5	8
			6	5
21439	9C00015-15	5975-01-418-5108	3	10

## CROSS-REFERENCE INDEXES

## PART NUMBER INDEX

CAGEC	PART NUMBER	STOCK NUMBER	FIG.	ITEM
21439	9C00015-16	5310-01-418-6243	1	2
			2	28
21439	9C00015-17	5330-01-393-5637	2	19
			3	9
21439	9C00015-18	5330-01-393-4855	1	20
			2	26
			3	3
21439	9C00015-2	5935-01-393-7232	3	8
21439	9C00015-6		2	20
21439	9C00015-9		1	19
			3	4
0KZG3	90012	6210-01-417-7034	5	4
52793	934050-29	5310-01-429-5029	9	14
13548	93906	5995-01-096-0733	6	2
0KZG3	99595-3		5	3



## APPENDIX D

### COMPONENTS OF END ITEM AND BASIC ISSUE ITEMS LISTS

---

#### Section I. INTRODUCTION

---

##### D-1. SCOPE.

---

This appendix lists Components of End Item and Basic Issue Items for the M1022A1 Dolly Set to help you inventory items required for safe and efficient operation of the equipment.

---

##### D-2. GENERAL.

---

The Components of End Item (COEI) and Basic Issue Items (BII) Lists are divided into the following sections:

a. **Section II, Components of End Item.** This listing is for informational purposes only and is not authority to requisition replacements. These items are part of the dolly set. As part of the end item, these items must be with the end item whenever it is issued or transferred between property accounts. Items of COEI are removed and separately packaged for transportation or shipment only when necessary. Illustrations are furnished to help you find and identify the items.

b. **Section III, Basic Issue Items.** These essential items are required to place the dolly set in operation, to operate it, and to perform emergency repairs. Although shipped separately packaged, BII must be with the dolly set during operation and whenever it is transferred between property accounts. This list is your authority to request/requisition them for replacement based upon authorization of the end item by TOE/MTOE. Illustrations are furnished to help you find and identify the items.

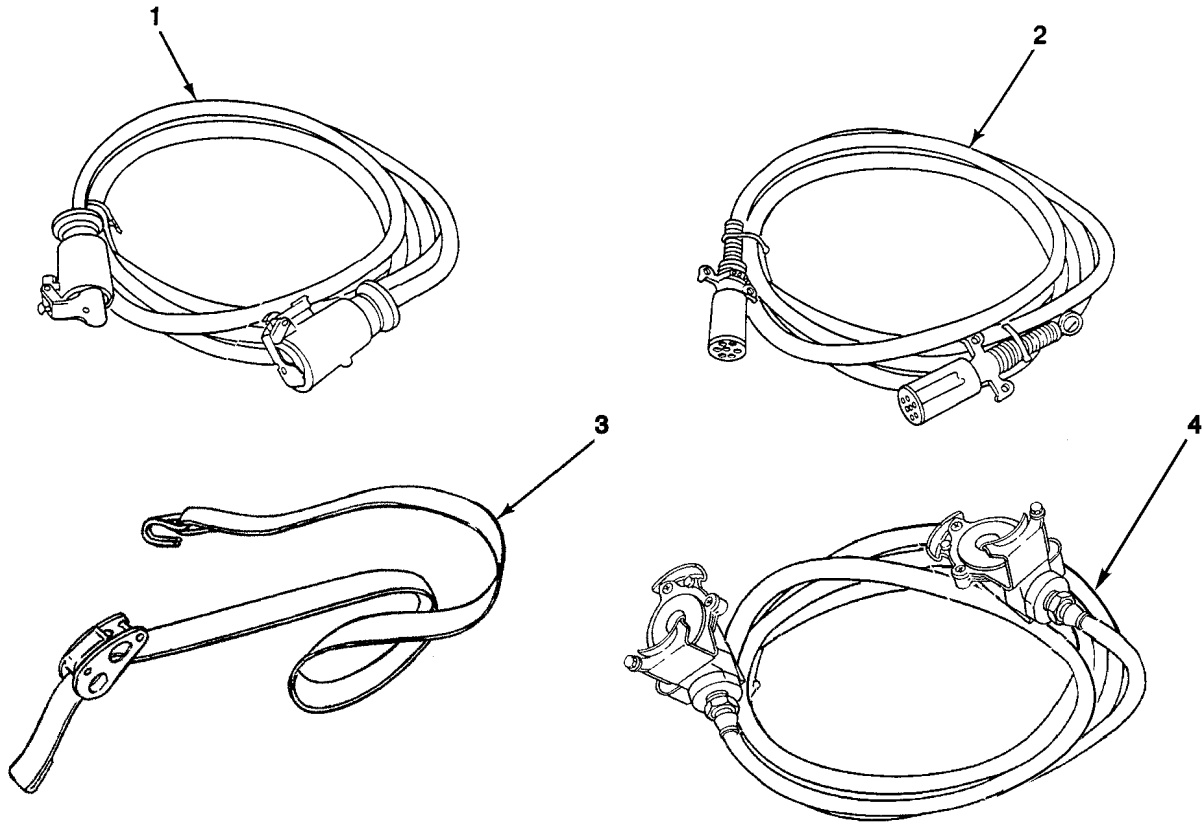
---

##### D-3. EXPLANATION OF COLUMNS.

---

- a. **Column (1) - Illustration Number (Illus Number).** This number identifies the item illustrated.
- b. **Column (2) - National Stock Number.** Identifies the National Stock Number (NSN) assigned to the item. Use it to request or requisition the item.
- c. **Column (3) - Description and Usable On Code.** Indicates the Federal Item Name and, if required, a description to identify and locate the item. The last line for each item indicates the Commercial and Government Entity (CAGE) Code in parentheses, followed by the part number.
- d. **Column (4) -Unit of Issue (U/I).** Indicates how the item is issued for the NSN identified in Column 2. This measure is expressed by a two-character alphabetical abbreviation (e.g., ea, in., pr).
- e. **Column (5) - Quantity Required (Qty Rqd).** Indicates the quantity required.

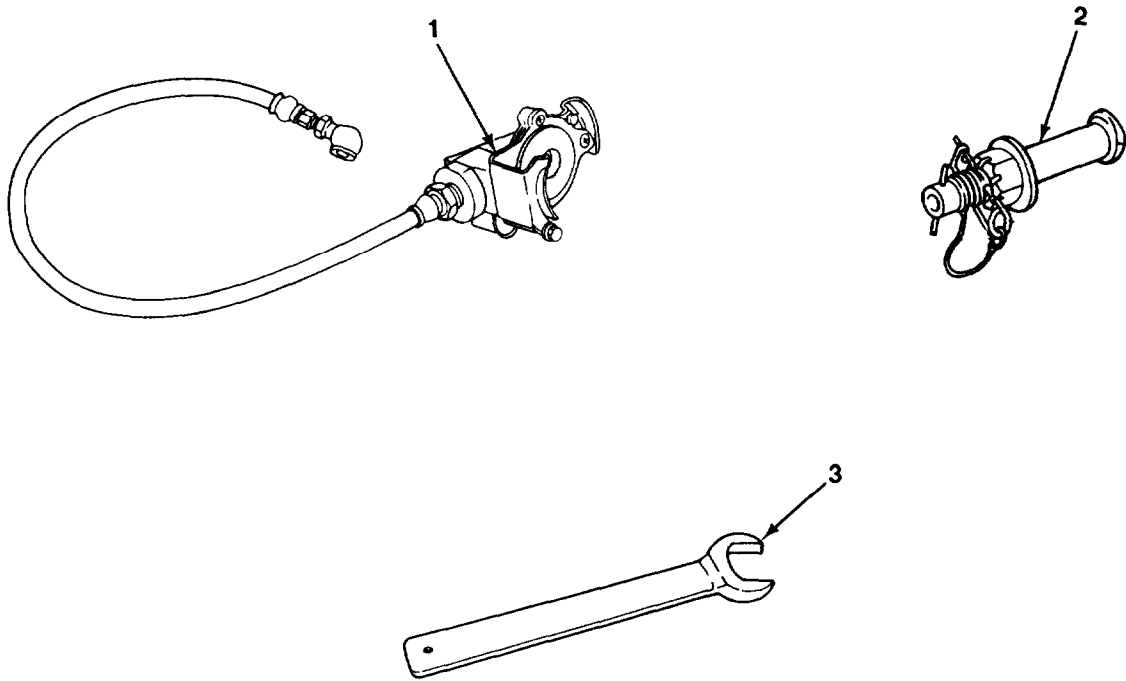
**Section II. COMPONENTS OF END ITEM**



(1) Illus Number	(2) National Stock Number	(3) Description (CAGE) Part Number	(4) Usable On Code U/I	(5) Qty Rqd
1		CABLE ASSEMBLY, MILITARY (21439) 8D00066-1	ea	1
2		CABLE ASSEMBLY, SAE (21439) 8D00066-2	ea	1
3		STRAP ASSEMBLY (21439) 8D00223-1	ea	6
4		HOSE ASSEMBLY, PNEUMATIC (1NHH8) 8D00063-5 (1NHH8) 8D00063-6	ea ea	1 1



Section III. BASIC ISSUE ITEMS



(1) Illus Number	(2) National Stock Number	(3) Description (CAGE) Part Number	Usable On Code	(4) U/I	(5) Qty Rqd
1		CHARGING ASSEMBLY, AIR BAG (21439) 8D00054-1		ea	1
2		TWIST LOCK ASSEMBLY (21439) 8D00137-1		ea	8
3		WRENCH, TWIST LOCK (21439) 8D00136		ea	1



**APPENDIX E  
ADDITIONAL AUTHORIZATION LIST**

**Section I. INTRODUCTION**

**E-1. SCOPE.**

This appendix lists additional items that you are authorized for the support of the Dolly Set: Lift, Transportable Shelter, M1022A1.

**E-2. GENERAL.**

This list identifies items that do not have to accompany the dolly set and that do not have to be turned in with it. These items are authorized to you by CTA, MTOE, TOA, and JTA.

**E-3. EXPLANATION OF LISTING.**

National Stock Numbers, description, and quantities are provided to help you identify and request the additional items you require to support this equipment.

**Section II. ADDITIONAL AUTHORIZATION LIST**

(1) National Stock Number	(2) Description (CAGE) Part Number	Usable On Code	(3) U/I	(4) Qty Auth
	Kit, Cold Start (21439) 8D00350-1		ea	2



## APPENDIX F EXPENDABLE AND DURABLE ITEMS LIST

---

### Section I. INTRODUCTION

---

#### F-1. SCOPE.

---

This appendix lists expendable and durable items you will need to operate and maintain the M1022A1 Dolly Set. This listing is for informational purposes only and is not authority to requisition the listed items. These items are authorized to you by CTA 50-970, *Expendable/Durable Items (Except Medical, Class V, Repair Parts, and Heraldic Items)* or CTA 8-100, *Army Medical Department Expendable/Durable Items*.

---

#### F-2. EXPLANATION OF COLUMNS.

---

a. **Column (1) - Item Number.** This number is assigned to the entry in the listing and is referenced in the "Initial Setup" of maintenance paragraphs or narrative instructions to identify the material needed (e.g., Dry cleaning solvent, Item 27, Appendix F).

b. **Column (2) - Level.** This column identifies the lowest level of maintenance that requires the listed item.

*C . . . . . Unit (Operator or Crew)*

*O . . . . . Unit Maintenance*

*F . . . . . Direct Support Maintenance*

*H . . . . . General Support Maintenance*

*D . . . . . Depot Maintenance*

c. **Column (3) - National Stock Number.** Identifies the National Stock Number (NSN) assigned to the item. Use it to request or requisition the item.

d. **Column (4) - Description.** Indicates the Federal Item Name and, if required, a description to identify the item. The last line for each item indicates the Commercial and Government Entity (CAGE) Code in parentheses followed by the part number.

e. **Column (5) - Unit of Measure (U/M)/Unit of Issue (U/I).** This measure is expressed by a two-character alphabetical abbreviation (e.g., ea, in., pr). If the unit of measure differs from the unit of issue as shown in the Army Master Data File (AMDF), requisition the lowest unit of issue that will satisfy your requirements.

**Section II. EXPENDABLE AND DURABLE ITEMS LIST**

(1) Item Number	(2) Level	(3) National Stock Number	(4) Description (CAGE) Part Number	(5) U/M U/I
1	O	8040-01-284-3984	ADHESIVE (05972) 38050 1 Ounce can	oz
2	C	8135-00-753-4662	BARRIER MATERIAL: Greaseproof, Waterproofed, Flexible (81349) MIL-B-121 100 Yard Roll	yd
3	C	7920-00-061-0038	BRUSH: Scrub (83421) 7920-00-061-0038	ea
4	C	7920-00-900-3577	BRUSH: Wire (17987) 15SS	ea
5	O	5350-00-187-6294	CLOTH: Abrasive, Aluminum Oxide (83421) 5350-00-187-6294 50 Yard Roll	yd
6	O	5350-00-221-0872	CLOTH: Abrasive, Crocus (58536) A-A-1206 Package of 50	ea
7	C	7930-00-899-9534	COMPOUND: Dishwashing, Hand (83421) 7930-00-899-9534 5 Gallon Can	gl
8	F	8030-01-303-0502	COMPOUND: Sealing (05972) 68035 50 Cubic Centimeter Bottle	cc
9	O		COMPOUND: Sealing, Pneumatic/Hydraulic Seal (05972) 54531 50 Cubic Centimeter Bottle	cc
10	O	8030-01-104-5392	COMPOUND: Sealing, Resin, Type II, Grade N (05972) 242-41 10 Cubic Centimeter Bottle	cc

Section II. EXPENDABLE AND DURABLE ITEMS LIST (Con't)

(1) Item Number	(2) Level	(3) National Stock Number	(4) Description (CAGE) Part Number	(5) U/M U/I
11	H	8030-01-063-7510	COMPOUND: Sealing, Thread-locking (81349) MIL-S-46163TY1GRL 50 Cubic Centimeter Bottle	cc
12	O	6850-01-159-4844	COMPOUND: Silicone, RTV Rubber Sealant (11862) 1052914 101/7 Ounce Tube	oz
13	C	7930-00-282-9699	DETERGENT: General Purpose, Liquid (83421) 7930-00-282-9699 1 Gallon Can	gl
14	O	6810-00-249-9354	ELECTROLYTE: Sulfuric Acid (19207) 10875529 1 Gallon Bottle	gl
15	C	9150-00-252-6383 9150-01-223-4134 9150-00-082-7524 9150-00-265-9408	FLUID: Hydraulic, Petroleum Base, OHA (81349) MIL-H-5606 1 Quart Can 1 Gallon Can 10 Gallon Drum 55 Gallon Drum	qt gl gl gl
16	O	3439-00-255-9935	FLUX: Soldering (58536) A-A-51145 TY1 Form A 1 Pound Can	lb
17	C	9140-00-286-5295 9140-00-286-5296 9140-00-286-5297	FUEL, DIESEL: DF-2 Grade (81348) VVF800GRADEDFAAR 5 Gallon Can 55 Gallon Drum, 16 Gage 55 Gallon Drum, 18 Gage	gl gl gl
18	C	9140-00-286-5282 9140-00-286-5284 9140-00-286-5285	FUEL, DIESEL: DF-A Grade (81348) VVF800GRADEDFAAR 5 Gallon Can 55 Gallon Drum, 16 Gage 55 Gallon Drum, 18 Gage	gl gl gl

Section II. EXPENDABLE AND DURABLE ITEMS LIST (Con't)

(1) Item Number	(2) Level	(3) National Stock Number	(4) Description (CAGE) Part Number	(5) U/M U/I
19	O		GREASE: Aircraft, WTR (81349) MIL-G-81322	
		9150-01-262-3358	14 Ounce Cartridge	oz
		9150-00-181-7724	8 Ounce Tube	oz
		9150-00-935-5851	35 Pound Can	lb
		9150-01-237-7468	120 Pound Drum	lb
20	O	5970-00-767-0524	INSULATION SLEEVING: Electrical, 1/4 Inch Inside Diameter (92194) FIT-221-1/4CLEAR	ft
21	C		OIL: Lubricating, Engine, Arctic, OEA (81349) MIL-L-46167	
		9150-00-402-4478	1 Quart Can	qt
		9150-00-402-2372	5 Gallon Can	gl
		9150-00-491-7197	55 Gallon Drum	gl
22	C		OIL: Lubricating, Engine, OE/HDO 10 (81349) MIL-L-2104	
		9150-00-189-6727	1 Quart Can	qt
		9150-00-186-6668	5 Gallon Can	gl
		9150-00-191-2772	55 Gallon Drum	gl
23	C		OIL: Lubricating, Engine, OE/HDO 30 (81349) MIL-L-2104	
		9150-00-186-6681	1 Quart Can	qt
		9150-00-188-9858	5 Gallon Can	gl
		9150-00-189-6729	55 Gallon Drum	gl
24	O		OIL: Lubricating, General Purpose, Preservative, PL-S (81348) V-VL-800	
		9150-00-231-6689	1 Quart Can	qt
25	C		RAG: Wiping (64067) 7920-00-205-1711	
		7920-00-205-1711	50 Pound Bale	lb
26	O		SOLDER: Lead Alloy (81348) SN10WRP2 0.063 1LB	
		3439-00-265-7102	1 Pound Spool	lb



## Section II. EXPENDABLE AND DURABLE ITEMS LIST (Con't)

(1) Item Number	(2) Level	(3) National Stock Number	(4) Description (CAGE) Part Number	(5) U/M U/I
27	C		SOLVENT: Dry Cleaning, Type II (81348) P-D-680	1
		6850-00-110-4498	1 Pint Can	pt
		6850-00-664-5685	1 Quart Can	qt
		6850-00-281-1985	1 Gallon Can	gl
		6850-00-274-5421	5 Gallon Can	gl
		6850-00-285-8011	55 Gallon Drum	gl
28	O		TAG: Marker (81349) MIL-T-12755	
		9905-00-537-8954	Bundle of 50	ea
29	O		TAPE: Antiseize, 1/2 Inch Width (81349) MIL-T-27730	
		8030-00-889-3535	260 Inch Spool	in
30	C		TAPE: Duct, 2 Inch Width (39428) 1791K70	
		5640-00-103-2254	60 Yard Roll	yd
31	O		TAPE: Pressure Sensitive Adhesive, Masking, Flat, 1 Inch Width (19203) 8783476	
		7510-00-266-6712	60 Yard Roll	yd
32	C		TAPE: Pressure Sensitive Adhesive, Masking Flat, 2 Inch Width (81349) MIL-T-23397	
		7510-00-473-9513	60 Yard Roll	yd
33	O	9330-00-402-5407	TUBING: Nonmetallic, 0.187 Inch Inside Diameter (81349) MIL-P-22296	ft
34	O		WIRE: Nonelectrical (81346) AMSTA A641	
		9505-00-596-0191	5 Pound Roll	lb
35	O		GREASE: Automotive and Artillery, GAA (81349) M-10924-C	
		9150-01-197-7690	1-3/4 Pound Can	lb
36	O		TAPE: Pressure Sensitive Adhesive, 2 Inch Width (52152) 481 2 IN. BLACK	
		7510-00-852-8180	36 Yard Roll	yd



## APPENDIX G

### TOOL IDENTIFICATION LIST

---

#### Section I. INTRODUCTION

---

#### G-1. GENERAL.

---

This appendix lists tools you will need to maintain the M1022A1 Dolly Set. This listing is for informational purposes only and is not authority to requisition the tools. Common tools are found in the supply catalogs and special tools are found in Appendix C of this manual.

---

#### G-2. DEFINITION OF COLUMNS.

---

- a. Column (1) - Item Number (Item No.). This number is assigned to the entry in the listing and is referenced in the "Initial Setup" of maintenance paragraphs or narrative instructions to identify the tool needed (e.g., General mechanic's tool kit, Item 30, Appendix G).
- b. Column (2) - Item Name. Identifies the tool or tool set name and, if required, a description to identify the tool.
- c. Column (3) - National Stock Number. Identifies the National Stock Number (NSN) assigned to the tool. Use it to request or requisition the tool.
- d. Column (4) - (CAGE) Part Number. When no NSN is available, a Commercial and Government Entity (CAGE) Code followed by a part number will be used where possible.
- e. Column (5) - Reference. Indicates the technical manual or supply catalog in which the tool can be found.

Section II. TOOL IDENTIFICATION LIST

(1) Item No.	(2) Item Name	(3) National Stock Number	(4) (CAGE) Part Number	(5) Reference
1	Adapter, Socket Wrench: 3/8 in. to 1/2 in.	5120-00-240-8703	(58538) A-A-2172	GSA Catalog
2	Bushing, Pipe		(30780) 0502-8-4	Appendix C
3	Caliper, Micrometer, Inside	5210-00-221-1921	(81348) GGG-C-105	SC 4940-95-A31
4	Compressor Unit, Reciprocating	4310-00-752-9633	(81349) MILC13874	SC 4910-95-CL-A74
5	Crowfoot Attachment: 3/8 in. drive	5210-00-229-2772	(30106) TF-32	GSA Catalog
6	Cylinder, Compressed Gas: for acetylene	8120-00-268-3360	(81349) MIL-C-3701	SC 4910-95-A31
7	Cylinder, Compressed Gas: for oxygen	8120-00-357-7992	(81348) C901/1-15	SC 4910-95-A31
8	Drill, Electric, Portable	5130-00-293-1849	(81348) W-D-661	SC 4910-95-CL-A74
9	Drill Set, Twist	5133-00-293-0983	(55719) DB129B	SC 4910-95-CL-A74
10	Duplex Hose, Rubber	4720-01-043-4099	(30367) 574F92	SC 4910-95-A31
11	Gage, Pressure, Dial: 0-6000 psi	6685-01-373-7976	(61349) 151469	Appendix C
12	Gloves, Welder's	8415-00-268-7859	(58536) A-A-50022	SC 4910-95-A31
13	Goggles, Industrial	4240-00-816-3819	(74936) WA60-5H0746-0315	SC 4910-95-A31
14	Gun, Air Blow	4940-00-333-5541	(17431) DGA520	SC 4910-95-CL-A74
15	Igniter, Friction	5120-00-965-0326	(81337) 5-13-2003-55	SC 4910-95-A31
16	Jack, Dolly Type, Hydraulic: 10 ton capacity	4910-00-289-7233	(36251) 93660	SC 4910-95-A31
17	Jack, Hydraulic: 12 ton capacity	5120-00-224-7330	(07505) 67224	SC 4910-95-CL-A74
18	Lathe, Brakedrum	4910-01-028-9849	(4T928) 4100	SC 4910-95-A31
19	Lubricating Gun, Hand	4930-00-253-2478	(81349) M3859/1-14	SC 4910-95-CL-A74
20	Multimeter, Digital	6625-01-139-2512	(80058) AN/USM-451	SC 4910-95-CL-A74

## Section II. TOOL IDENTIFICATION LIST (Con't)

(1) Item No.	(2) Item Name	(3) National Stock Number	(4) (CAGE) Part Number	(5) Reference
21	Pliers, Brake Repair	5120-00-690-8044	(81348) GGG-P-00474	SC 4910-95-CL-A74
22	Puller Kit, Mechanical: gear and bearing	5120-00-423-1596	(45225) PE12	SC 4910-95-CL-A74
23	Press, Arbor	3444-00-449-7295	(80244) A-A-51194	SC 4910-95-A31
24	Riveter, Blind Hand: 3/32 in., 1/8 in., 5/32 in., and 3/18 in. diameters	5120-00-017-2849	(10054) 250K	SC 4910-95-CL-A74
25	Soldering Gun	3439-00-618-6623	(97049) D550-3	SC 4910-95-CL-A74
26	Stepladder: 8 ft, aluminum alloy	5440-00-514-4487	(83421) 5440-00-514-4487	GSA Catalog
27	Stud Remover and Inserter: wedge type	5120-00-596-0980	(93389) 4515	SC 4910-95-CL-A72
28	Tape, Measuring: 50 ft	5210-00-554-7085	(81348) GGG-T-106	SC 4910-95-CL-A72
29	Tool Kit, Electrical Connector Repair	5180-00-876-9336	(19264) 7550526	SC 4910-95-CL-A74
30	Tool Kit, General Mechanic's: Automotive	5180-00-177-7033	(50980) SC5180-90-CL-N26	SC 5180-90-N26
31	Torch Set, Cutting and Welding	3433-00-294-6743	(81349) MIL-T-13880	SC 4910-95-A31
32	Trestle, Motor Vehicle Maintenance: 7 ton capacity	3950-00-251-8013	(79805) 306	SC 4910-95-CL-A74
33	Truck, Hand, Two-wheeled: gas cylinder type	3920-00-113-0117	(81348) KKK-T-683	SC 4910-95-A31
34	Valve, Regulating, Fluid Pressure: for acetylene	4820-00-285-6067	(63026) 0781-3983	SC 4910-95-A31
35	Valve, Regulating, Fluid Pressure: for oxygen	4820-00-641-3519	(81349) MILR13877	SC 4910-95-A31
36	Vise, Machinist's	5120-00-293-1439	(79416) 504M2	SC 4910-95-CL-A74

**Section II. TOOL IDENTIFICATION LIST (Con't)**

(1) Item No.	(2) Item Name	(3) National Stock Number	(4) (CAGE) Part Number	(5) Reference
37	Wrench, Adjustable: 0-35/8 in. jaw opening	5120-00-449-8083	(11083) 1B7536	SC 4910-95-CL-A74
38	Wrench Set, Socket: 3/4 in. drive, wheel bearing	5120-00-169-4586	(45225) Z62-D	SC 4910-95-CL-A74
39	Wrench Set, Socket: 3/4 in. drive	5120-00-204-1999	(81348) GGG-W-641	SC 4910-95-CL-A74
40	Wrench, Strap, Pipe: 1-6 in. diameter	5120-00-776-1840	(55719) S-18	GSA Catalog
41	Wrench, Torque: 3/8 in. drive, 0-200 lb.-in. capacity	5120-00-853-4538	(90947) F2001	SC 4910-95-CL-A72
42	Wrench, Torque: 1/2 in. drive, 0-175 lb.-ft capacity	5120-00-640-6364	(08194) 1753LDF	SC 4910-95-CL-A74
43	Wrench, Torque: 3/4 in. drive, 0-600 lb.-ft. capacity	5120-00-221-7983	(10001) SW130-301	SC 4910-95-CL-A72

## APPENDIX H TORQUE LIMITS

---

---

### H-1. SCOPE.

---

This appendix lists standard torque values (see Table H-1) and engine torque values (see Table H-2), and provides general information for applying torque. Special torque values and tightening sequences are indicated in the maintenance procedures for applicable components.

---

### H-2. GENERAL.

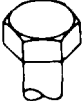


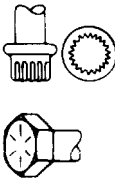
---

- a. Always use the torque values listed in Table H-1 or Table H-2 when the maintenance procedure does not give a specific torque value.
- b. Unless otherwise indicated, standard torque tolerance shall be  $\pm 10\%$ .
- c. Torque values listed are based on clean, dry threads. Reduce torque by 10% when engine oil is used as a lubricant. Reduce torque by 20% if new plated capscrews are used.
- d. Capscrews threaded into aluminum may require reductions in torque of 30% or more of Grade 5 capscrews torque. Capscrew threaded into aluminum must also attain two capscrew diameters of thread engagement.

**CAUTION**

If replacement capscrews are of higher grade than originally supplied, use torque specifications for the original. This will prevent equipment damage due to overtorquing.

Table H-1. Torque Limits.




Current Usage	Much Used	Much Used	Used at Times	Used at Times
Quality of Material	Indeterminate	Minimum Commercial	Medium Commercial	Best Commercial
SAE Grade Number	1 or 2	5	6 or 7	8
Capscrew Head Markings  Manufacturer's marks may vary  These are all SAE Grade 5 (3 line)				
Capscrew Body Size Inches - Thread	Torque lb.-ft. (Nom)	Torque lb.-ft. (Nom)	Torque lb.-ft. (Nm)	Torque lb.-ft. (Nom)
1/4 20	5 (7)	8 (11)	10 (14)	12 (16)
28	6 (8)	10 (14)		14 (19)
5/16 18	11 (15)	17 (23)	19 (26)	24 (33)
24	13 (18)	19 (26)		27 (37)
3/8 16	18 (24)	31 (42)	34 (46)	44 (60)
24	20 (27)	35 (47)		49 (66)
7/18 14	28 (38)	49 (66)	55 (75)	70 (95)
20	30 (41)	55 (75)		78 (106)
1/2 13	39 (53)	75 (102)	85 (115)	105 (142)
20	41 (56)	85 (115)		120 (163)
9/16 12	51 (69)	110 (149)	120 (163)	155 (210)
18	55 (75)	120 (163)		170 (231)
5/8 11	83 (113)	150 (203)	167 (226)	210 (285)
18	95 (129)	170 (231)		240 (325)
3/4 10	105 (142)	270 (366)	280 (380)	375 (508)
16	115 (156)	295 (400)		420 (569)
	160 (217)			605 (820)
7/8 9	175 (217)	395 (536)	440 (597)	675 (915)
14		435 (590)		
1 8	235 (319)	590 (800)	660 (895)	910 (1234)
14	250 (339)	660 (895)		990 (1342)



**NOTE**

Engine screw and bolt material grades are indicated by numbers punched on screw and bolt heads. Prior to tightening, check material grade number.

**Table H-2. Engine Torque Limits.**

Grade	Standard Screw and Bolt		Special Screw and Bolt		
					
Nominal Diameter in Millimeters	Torque			Torque	
	lb.-ft.	(N . m)	lb.-ft.	(N m)	
6	5.83 to 6.86	(7.90 to 9.30)	7.23 to 8.33	(9.80 to 11.30)	
8	13.05 to 15.19	(17.70 to 20.60)	17.33 to 20.28	(23.50 to 27.50)	
10	28.91 to 33.26	(39.20 to 45.10)	35.47 to 41.22	(48.10 to 55.90)	
12	46.31 to 53.54	(62.80 to 72.60)	57.15 to 66.52	(77.50 to 90.20)	



INDEX

Subject	Paragraph	Page
<b>A</b>		
Adhesive, Application of .....	4-16	4-9
Adjustment:		
Brake:		
Major .....	4-58	4-126
Minor .....	4-59	4-130
Injection Pump Timing .....	4-120	4-346
Wheel Bearing .....	4-75	4-191
Administrative Storage:		
Airbrake System Valves .....	4-143	4-404
Definition .....	4-140	4-401
Equipment:		
Care .....	4-142	4-403
Preparation .....	4-141	4-401
Removal .....	4-144	4-404
Exercise Schedule .....	Table 4-3	4-404
Seals .....	4-143	4-404
Tires .....	4-143	4-404
Air Bags:		
Inflation.. .....	2-22	2-139
Replacement .....	4-101	4-255
Air Cleaner:		
Element:		
Cleaning .....	3-10	3-28
Replacement .....	4-123	4-357
Replacement .....	4-123	4-357
Air Lines:		
Front Dolly .....	4-72	4-166
Rear Dolly .....	4-73	4-177
Air Reservoir:		
Draining .....	3-6	3-20
Replacement:		
Front Dolly .....	4-62	4-140
Rear Dolly .....	4-66	4-152
Airbrake:		
Chamber .....	4-61	4-136
Leakage Check .....	4-23	4-13
Schematics .....	4-74	4-188
Valve:		
Preparation for Storage .....	4-143	4-404
Replacement .....	4-65	4-148
Aircraft Loading .....	4-146	4-405
Alinement; Wheel .....	4-77	4-201
Alinement, Front Axle .....	4-55	4-119

**INDEX**

Subject	Paragraph	Page
Antiseize Tape .....	4-24	4-13
Army Materiel, Destruction .....	1-3	1-1
Assembly Instructions, General Maintenance .....	4-13	4-9
Attaching Dollies:		
Side Lift Operation:		
Shelter On Ground .....	2-12	2-84
Shelter On Trailer .....	2-13	2-92
Standard Operation:		
To Each Other .....	2-10	2-67
To Shelter .....	2-9	2-59
Axle:		
Front .....	5-1	5-1
Rear .....	5-1	5-1

**B**

Battery:		
Cables .....	4-45	4-8
Case .....	4-44	4-80
Replacement .....	4-43	4-78
Service.. ..	4-43	4-78
Test .....	4-43	4-78
Beam:		
Bottom .....	4-83	4-222
Top .....	4-83	4-222
Bearing:		
Cleaning .....	4-9e	4-8
Wheel:		
Adjustment .....	4-75	4-191
Maintenance.. ..	4-75	4-191
Blackout Stoplight-Taillight .....	4-39	4-70
Bleeding, Hydraulic:		
M1022A1 With Side Lift Kit .....	4-113	4-315
M1022A1 Without Side Lift Kit. ....	4-112	4-312
Booster Relay Valve:		
Front Dolly .....	4-63	4-144
Rear Dolly .....	4-67	4-156
Bottom Beam .....	4-83	4-222
Brace:		
Front Dolly .....	4-94	4-244
Pivoting Tray Lockout .....	4-98	4-248
Telescopic .....	4-86	4-232

**INDEX**

Subject	Paragraph	Page
Bracket:		
Hanger .....	4-100	4-253
Hydraulic Control Valve:		
Front Dolly .....	4-93	4-243
Rear Dolly .....	4-96	4-246
Junction Box:		
Front Dolly .....	4-92	4-242
Rear Dolly .....	4-95	4-245
Pivot Axle .....	4-82	4-218
Pivoting Tray:		
Lower .....	4-98	4-248
Upper .....	4-98	4-248
Shutoff Valve Mounting .....	4-68	4-158
Storage Box Mounting .....	4-137	4-398
Toolbox Mounting .....	4-97	4-247
Brake:		
Adjustment:		
Major .....	4-58	4-126
Minor .....	4-59	4-130
Airbrake Chamber .....	4-61	4-136
Brakeshoe .....	4-57	4-124
Caging .....	4-56	4-121
Parking:		
Lever .....	4-69	4-160
Valve .....	4-69	4-160
Principles of Operation .....	1-18	1-33
Spider Assembly .....	4-60	4-131
Uncaging .....	4-56	4-121
Brakedrum:		
Maintenance .....	4-75	4-191
Repair .....	5-3	5-7
Brakeshoe .....	4-57	4-124

**C**

Cable:		
Battery .....	4-45	4-81
Electrical, Cleaning .....	4-9d	4-7
Forward Junction Box-to-Signal Conditioning Box .....	4-46	4-84
Identification Light .....	4-49	4-10
Marker Clearance Light .....	4-47	4-89
Signal Conditioning Box-to-Forward Junction Box .....	4-46	4-84
Taillight Assembly .....	4-48	4-95
Caging Brakes .....	4-56	4-121
Capabilities of Equipment .....	1-10	1-4

INDEX

Subject	Paragraph	Page
Care, Handling, and Safety .....	1-8	1-2
Case:		
Battery .....	4-44	4-80
Spiral .....	4-128	4-378
Caster Wheel Assembly .....	4-91	4-239
Castings, Cleaning .....	4-9c	4-7
Chains, Safety:		
Mounting .....	4-52	4-113
Replacement .....	4-51	4-111
Chamber, Airbrake .....	4-61	4-136
Characteristics of Equipment .....	1-10	1-4
Checking:		
Crankcase Oil .....	3-8	3-23
Engine Fuel .....	3-9	3-26
Hydraulic Fluid .....	3-7	3-21
Circuit Breaker (Signal Conditioning Box) .....	4-34	4-49
Cleaning Instructions, General Maintenance:		
Bearings .....	4-9e	4-8
Cables, Electrical .....	4-9d	4-7
Castings.. .....	4-9c	4-7
Forgings .....	4-9c	4-7
Hoses, Flexible .....	4-9d	4-7
Machined Metal Parts .....	4-9c	4-7
Oil Seals .....	4-9d	4-7
Steam Cleaning .....	4-9b	4-6
■ Cold Start Kit, Installation .....	4-138.1	4-400
Cold Weather, Operation in .....	2-24	2-143
Conditioning Box, Signal:		
Cable Assembly .....	4-46	4-84
Repair.. .....	4-34	4-49
Replacement .....	4-33	4-47
To Forward Junction Box Cable Assembly .....	4-46	4-84
Control Valve, Hydraulic:		
Operation .....	2-21	2-131
Repair .....	5-6	5-15
Replacement:		
Front Dolly .....	4-108	4-274
Rear Dolly .....	4-108	4-274
Controls and Indicators .....	2-2	2-1
Corrosion Prevention and Control (CPC) .....	1-9	1-3
Coupling Dolly Set to Towing Vehicle .....	2-11	2-76

## INDEX

Subject	Paragraph	Page
Cover:		
Rocker Arm .....	4-117	4-337
Side .....	4-126	4-374
Cowling, Cylinder .....	4-128	4-378
CPC (Corrosion Prevention and Control) .....	1-9	1-3
Crankcase Oil:		
Checking .....	3-8	3-23
Filling .....	3-8	3-23
Replacement .....	4-118	4-340
Cylinder:		
Cowling .....	4-128	4-378
Hydraulic Lift:		
Repair:		
M1022A1 With Side Lift Kit .....	5-9	5-34
M1022A1 Without Side Lift Kit .....	5-6	5-20
Replacement .....	4-110	4-301
Positioning:		
Repair:		
M1022A1 With Side Lift Kit .....	5-11	5-48
M1022A1 Without Side Lift Kit .....	5-8	5-25
Replacement .....	4-83	4-222

D

Data:		
Equipment .....	1-15	1-24
Plates:		
Content .....	1-12	1-11
Location .....	1-12	1-11
Replacement .....	4-105	4-266
Specifications .....	1-15	1-24
Warranty .....	1-7	1-2
Decals:		
Content .....	1-13	1-21
Location .....	1-13	1-21
Replacement .....	4-106	4-267
Description of Major Components .....	1-11	1-6
Designations, Nomenclature, and Names .....	1-5	1-2
Destruction of Army Materiel .....	1-3	1-1
Detaching Dollies:		
Side Lift Operation:		
Shelter On Ground .....	2-16	2-110
Shelter On Trailer .....	2-15	2-103
Standard Operation .....	2-8	2-52

INDEX

Subject	Paragraph	Page
Diagram, Wiring:		
Electrical .....	4-50	4-108
Engine .....	4-135	4-394
Disassembly Instructions, General Maintenance .....	4-13	4-9
Disposal of Fluid .....	4-25	4-13
Dolly, Front:		
Air Lines .....	4-72	4-166
Air Reservoir .....	4-62	4-140
Booster Relay Valve .....	4-63	4-144
Brace .....	4-94	4-244
Hydraulic Control Valve Bracket .....	4-93	4-243
Junction Box Bracket .....	4-92	4-242
Pivoting Tray .....	4-80	4-212
Pressure Protection Valve .....	4-64	4-146
Relay Emergency Valve .....	4-62	4-140
Dolly, Rear:		
Air Lines .....	4-73	4-177
Air Reservoir.. ..	4-66	4-152
Booster Relay Valve .....	4-67	4-156
Full Function Valve .....	4-66	4-152
Hydraulic Control Valve Bracket .....	4-99	4-246
Junction Box Bracket .....	4-95	4-245
Parking Brake:		
Lever .....	4-69	4-160
Valve .....	4-69	4-160
Pivoting Tray .....	4-81	4-215
Relay Valve .....	4-70	4-162
Shutoff Valve:		
Mounting Bracket .....	4-68	4-158
Replacement .....	4-68	4-15
Taillight Assembly Cable Assembly .....	4-48	4-95
Drawbar:		
Front:		
Bushing Replacement .....	5-2	5-4
Dummy Coupling .....	4-87	4-234
Replacement.. ..	4-53	4-114
Rear:		
Pin Assembly .....	4-89	4-236
Replacement .....	4-88	4-235
Drum, Brake:		
Maintenance.. ..	4-75	4-191
Repair .....	5-3	5-7
Dummy Coupling, Front Drawbar .....	4-87	4-234
Dusty Areas, Operation in .....	2-30	2-146



## INDEX

<i>Subject</i>	<i>Paragraph</i>	<i>Page</i>
<b>E</b>		
EIRs (Equipment Improvement Recommendations) .....	1-6	1-2
Electrical:		
Cable, Cleaning .....	4-9d	4-7
Ground Points .....	4-21	4-12
Principles of Operation .....	1-17	1-30
Repair .....	4-26	4-14
Wiring Diagrams .....	4-50	4-108
Element, Air Cleaner:		
Cleaning .....	3-10	3-28
Replacement .....	4-123	4-357
Emergency Valve, Relay .....	4-62	4-140
Enclosure Assembly Repair, Cold Stan Kit .....	4-138.2	4-400.3
Engine:		
Fuel:		
Checking .....	3-9	3-26
Draining .....	4-125	4-366
Filling .....	3-9	3-26
Operation:		
Below 0°F (-18°) .....	2-25	2-144
Normal .....	2-20	2-129
Principles of Operation .....	1-22	1-41
Replacement .....	4-115	4-327
Winterizing Below 0°F (-18°C) .....	4-134	4-392
Wiring Diagram .....	4-135	4-394
Wiring Harness .....	4-132	4-386
Equipment Improvement Recommendations (EIRs) .....	1-6	1-2
Equipment:		
Capabilities .....	1-10	1-4
Characteristics .....	1-10	1-4
Data .....	1-15	1-24
Features .....	1-10	1-4
Specifications .....	1-15	1-24
Exercise Schedule .....	Table 4-3	4-404
<b>F</b>		
Features of Equipment .....	1-10	1-4
Filling:		
Crankcase Oil .....	3-8	3-23
Engine Fuel .....	3-9	3-26
Hydraulic Fluid .....	3-7	3-21
Fitter:		
Fuel .....	4-124	4-362
Oil .....	4-118	4-340
Fluid Disposal .....	4-25	4-13

## INDEX

<i>Subject</i>	<i>Paragraph</i>	<i>Page</i>
Fluid, Hydraulic:		
Checking .....	3-7	3-21
Filling .....	3-7	3-21
Flywheel Assembly .....	4-116	4-332
Fording Operations .....	2-33	2-149
Forgings, Cleaning .....	4-9c	4-7
Forms, Maintenance .....	1-2	1-1
Forward Junction Box:		
Cable Assembly .....	4-46	4-84
Repair .....	4-35	4-54
Replacement .....	4-33	4-47
To Signal Conditioning Box Cable Assembly .....	4-46	4-84
Frame, Principles of Operation .....	1-20	1-37
Front Axle .....	5-1	5-1
Front Dolly:		
Air Lines .....	4-72	4-166
Air Reservoir .....	4-62	4-140
Booster Relay Valve .....	4-63	4-144
Brace .....	4-94	4-244
Hydraulic Control Valve Bracket .....	4-93	4-243
Junction Box Bracket .....	4-92	4-242
Marker Clearance Light Cable Assembly .....	4-47	4-89
Pivoting Tray .....	4-80	4-212
Pressure Protection Valve .....	4-64	4-146
Relay Emergency Valve .....	4-62	4-140
Front Drawbar:		
Bushing Replacement .....	5-2	5-4
Dummy Coupling .....	4-87	4-234
Replacement .....	4-53	4-114
Fuel:		
c h e c k i n g .....	3-9	3-26
Draining .....	4-125	4-366
Filling .....	3-9	3-26
Filter .....	4-124	4-362
Lines .....	4-122	4-352
Strainer .....	4-124	4-362
Tank .....	4-126	4-366
Full Function Valve .....	4-66	4-152

## G

General Maintenance:		
Adhesive Application .....	4-16	4-9
Antiseize Tape .....	4-24	4-13
Assembly Instructions .....	4-13	4-9
Bearings, Cleaning .....	4-9e	4-8
Castings, Cleaning .....	4-9c	4-7

INDEX

Subject	Paragraph	Page
Cleaning Instructions .....	4-9	4-6
Disassembly Instructions .....	4-13	4-9
Electrical:		
Cables, Cleaning .....	4-9d	4-7
Ground Points.. .....	4-21	4-12
Repair .....	4-26	4-14
Fluid Disposal .....	4-25	4-13
Forgings, Cleaning.. .....	4-9c	4-7
General Instructions .....	4-7	4-4
Heat Shrinkable Tubing .....	4-20	4-11
Inspection Instructions .....	4-12	4-8
Leakage Check, Airbrake System .....	4-23	4-13
Lines .....	4-22	4-12
Lubrication Instructions .....	4-15	4-9
Machined Metal Parts, Cleaning .....	4-9c	4-7
Oil Seals, Cleaning .....	4-9d	4-7
Painting .....	4-11	4-8
Ports .....	4-22	4-12
Preservation of Parts .....	4-10	4-8
Repair Instructions .....	4-14	4-9
Soldering .....	4-19	4-11
Steam Cleaning .....	4-9b	4-6
Tagging:		
Hoses .....	4-18	4-11
Wires .....	4-18	4-11
Tool Requirements, Standard .....	4-17	4-10
Work Safety .....	4-8	4-5
Gladhand, Pivoting Tray .....	4-71	4-164
Glow Plug .....	4-133	4-390
Ground Points, Electrical .....	4-21	4-12

H

Handling, Safety, and Care .....	1-8	1-2
Hanger Bracket .....	4-100	4-253
Heat Shrinkable Tubing .....	4-20	4-11
Heat, Operation in .....	2-26	2-145
Hook, Top .....	4-84	4-229
Hose:		
Assemblies, Redundant Power Kit .....	4-136	4-395
Flexible, Cleaning .....	4-9d	4-7
Tagging.. .....	4-18	4-11
Hub Maintenance .....	4-75	4-191
Humid Areas, Operation in .....	2-29	2-146

INDEX

Subject	Paragraph	Page
Hydraulic:		
Bleeding:		
M1022A1 With Side Lift Kit .....	4-113	4-315
M1022A1 Without Side Lift Kit .....	4-112	4-312
Control Valve:		
Operation .....	2-21	2-131
Repair .....	5-6	5-15
Replacement:		
Front Dolly .....	4-108	4-274
Rear Dolly .....	4-108	4-274
Fluid:		
Checking .....	3-7	3-21
Draining .....	4-111	4-305
Filling .....	3-7	3-21
Lift Cylinder:		
Repair:		
M1022A1 With Side Lift Kit .....	5-10	5-34
M1022A1 Without Side Lift Kit .....	5-7	5-20
Replacement .....	4-110	4-301
Lines .....	4-109	4-287
Positioning Cylinder:		
Repair:		
M1022A1 With Side Lift Kit .....	5-9	5-48
M1022A1 Without Side Lift Kit .....	5-7	5-25
Replacement .....	4-83	4-222
Principles of Operation .....	1-21	1-39
Pump .....	4-107	4-269
Reservoir:		
Draining .....	4-111	4-305
Replacement.. .....	4-111	4-305
Schematics.. .....	4-114	4-324
I		
Identification Light:		
Cable Assembly .....	4-49	4-101
Maintenance .....	4-42	4-75
Indicators and Controls .....	2-2	2-1
Inflate Air Bags .....	2-22	2-139
Injection Pump:		
Nozzle Holder .....	4-121	4-350
Replacement .....	4-120	4-346
Timing Adjustment .....	4-120	4-346
Inspection Instructions:		
General Maintenance .....	4-12	4-8
Service Upon Receipt .....	4-5	4-2

**INDEX**

Subject	Paragraph	Page
Instructions, General Maintenance:		
Adhesive Application .....	4-16	4-9
Assembly .....	4-13	4-9
Disassembly .....	4-13	4-9
Electrical Repair .....	4-26	4-14
Inspection .....	4-12	4-8
Lubrication .....	4-15	4-9
Repair.. ..	4-14	4-9

**J**

Junction Box:		
Forward:		
Bracket .....	4-92	4-242
Cable Assembly .....	4-46	4-84
Repair .....	4-35	4-54
Replacement .....	4-33	4-47
Rear:		
Bracket .....	4-95	4-245
Repair .....	4-37	4-61
Replacement .....	4-36	4-59

**K**

Kit:		
Cold Start Installation .....	4-138.1	4-400
Redundant Power:		
Hose Assemblies .....	4-136	4-395
Operation .....	2-34	2-150
Side Lift Installation .....	5-9	5-31
Knuckle, Steering .....	4-54	4-116

**L**

Lamp:		
Identification Light .....	4-42	4-75
Marker Clearance Light .....	4-38	4-68
Taillight .....	4-40	4-72
Lanyard Assembly .....	4-99	4-250
Leakage:		
Check, Airbrake System .....	4-23	4-13
Definitions .....	2-10	4-18
Light:		
Blackout Stoplight-Taillight .....	4-39	4-70
Identification .....	4-42	4-75
Marker Clearance.. ..	4-38	4-68
Stoplight-Taillight, Blackout .....	4-39	4-70
Taillight .....	4-40	4-72

INDEX

Subject	Paragraph	Page
Lines:		
Fuel .....	4-122	4-352
General Maintenance .....	4-22	4-12
Hydraulic .....	4-109	4-287
Oil Cooler.. .....	4-119	4-344
Loading Shelter Onto Trailer (Side Lift Operation) .....	2-14	2-100
Location:		
Data Plates .....	1-12	1-11
Decals .....	1-13	1-21
Major Components .....	1-11	1-6
Stencils .....	1-14	1-23
Lockout, Transportation .....	4-85	4-230
Lower Bracket .....	4-98	4-248
Lowering Dolly Set:		
Side Lift Operation With Shelter .....	2-17	2-117
Standard Operation .....	2-8	2-52
Lubrication:		
Chart.. .....		3-2
Instructions:		
General Maintenance.. .....	4-15	4-9
Specific .....	3-1	3-1

M

Machined Metal Parts, Cleaning .....	4-9c	4-7
Maintenance		
Forms .....	1-2	1-1
Records .....	1-2	1-1
Reports .....	1-2	1-1
Major Brake Adjustment .....	4-58	4-126
Major Components, Location and Description .....	1-11	1-6
Maneuvering Position, Operating Hydraulic Control Valve .....	2-21	
2-132		
Marker Clearance:		
Cable Assembly .....	4-47	4-89
Lamp.. .....	4-38	4-68
Light .....	4-38	4-68
Minor Brake Adjustment .....	4-59	4-130
Mud, Operation in .....	2-27	2-145
Muffler .....	4-127	4-375

N

Names, Designations, and Nomenclature .....	1-5	1-2
Nomenclature, Names, and Designations .....	1-5	1-2
Nozzle Holder .....	4-121	4-350

## INDEX

Subject	Paragraph	Page
<b>O</b>		
Oil:		
Cooler:		
Lines .....	4-119	4-344
Replacement .....	4-117	4-337
Crankcase:		
Checking .....	3-8	3-23
Filling .....	3-8	3-23
Replacement .....	4-118	4-340
Filter .....	4-118	4-340
Seals Cleaning .....	4-9d	4-7
Operation:		
Engine:		
Below 0°F (-18°C) .....	2-25	2-144
Normal .....	2-20	2-129
Hydraulic Control Valve .....	2-21	2-131
Principles:		
Brake System .....	1-18	1-33
Electrical System .....	1-17	1-30
Engine Assembly .....	1-22	1-41
Frame Assembly .....	1-26	1-37
Hydraulic System .....	1-21	1-39
Steering System .....	1-19	1-35
Suspension Assembly .....	1-20	1-37
Redundant Power .....	2-34	2-150
Side Lift Procedures:		
Attaching Dollies to Shelter:		
Shelter On Ground .....	2-12	2-64
Shelter On Trailer .....	2-13	2-92
Detaching Dollies:		
Shelter On Ground .....	2-16	2-110
Shelter On Trailer .....	2-15	2-103
Loading Shelter Onto Trailer .....	2-14	2-100
Lowering Dolly Set With Shelter .....	2-17	2-117
Raising Dolly Set With Shelter .....	2-14	2-100
Standard Procedures:		
Attaching Dollies:		
To Each Other .....	2-10	2-67
To Shelter.. .....	2-9	2-59
Coupling Dolly Set to Towing Vehicle .....	2-11	2-76
Detaching Dollies .....	2-8	2-52
Lowering Dolly Set .....	2-6	2-52
Raising Dolly Set .....	2-11	2-76
Uncoupling Dolly Set from Towing Vehicle .....	2-7	2-45

INDEX

Subject	Paragraph	Page
Unusual Conditions:		
Cold .....	2-24	2-143
Dusty Areas .....	2-30	2-146
Fording .....	2-33	2-149
Heat .....	2-26	2-145
Humid Areas .....	2-29	2-146
Mud .....	2-27	2-145
Redundant Power .....	2-34	2-150
Rocky Terrain .....	2-31	2-146
Rough Terrain .....	2-31	2-146
Saltwater.. .....	2-28	2-145
Sandy Areas .....	2-30	2-146
Snow .....	2-24	2-143
Uneven .....	2-32	2-146
Operator/Crew:		
PMCS .....	2-3	2-8
Troubleshooting .....	3-3	3-9

P

Painting .....	4-11	4-8
Parking Brake:		
Lever .....	4-69	4-160
Valve.. .....	4-69	4-160
Parts, Preservation of .....	4-10	4-8
Pintle Assembly .....	4-90	4-238
Pivot Axle Bracket .....	4-62	4-218
Pivoting Tray:		
Front Dolly .....	4-80	4-212
Gladhand .....	4-71	4-164
Lockout Brace .....	4-98	4-248
Rear Dolly .....	4-81	4-215
Plates, Data:		
Contents .....	1-12	1-11
Location .....	1-12	1-11
Replacement .....	4-105	4-266
Ports, General Maintenance .....	4-22	4-12
Power, Redundant:		
Fittings .....	4-111	4-305
Kit Hose Assemblies .....	4-136	4-395
Operation .....	2-34	2-150
Preparation of Equipment:		
Administrative Storage .....	4-141	4-401
Shipment .....	4-145	4-405
Preservation of Parts .....	4-10	4-8
Pressure Protection Valve .....	4-64	4-146



**INDEX**

Subject	Paragraph	Page
Preventive Maintenance Checks and Services (PMCS):		
Operator/Crew .....	2-3	2-8
Unit .....	4-27	4-16
Principles of Operation:		
Brake System.. .....	1-18	1-33
Electrical System .....	1-17	1-30
Engine Assembly .....	1-22	1-41
Frame Assembly .....	1-20	1-37
Hydraulic System .....	1-21	1-39
Steering System .....	1-19	1-35
Suspension Assembly .....	1-20	1-37
Pump, Hydraulic .....	4-107	4-269
Pump, Injection:		
Nozzle Holder .....	4-121	4-350
Replacement .....	4-120	4-346
Timing Adjustment .....	4-120	4-346

**R**

Raising Doily Set:		
Side Lift Operation .....	2-14	2-100
Standard Operation .....	2-11	2-76
Rear Axle .....	5-1	5-1
Rear Dolly:		
Air Lines .....	4-73	4-177
Air Reservoir .....	4-66	4-152
Booster Relay Valve .....	4-67	4-156
Full Function Valve .....	4-66	4-152
Hydraulic Control Valve Bracket .....	4-96	4-246
Junction Box Bracket .....	4-95	4-245
Parking Brake:		
Lever .....	4-69	4-160
Valve .....	4-69	4-160
Pivoting Tray.. .....	4-81	4-215
Relay Valve .....	4-70	4-182
Shutoff Valve:		
Mounting Bracket .....	4-68	4-158
Replacement .....	4-68	4-158
Taillight Assembly Cable Assembly .....	4-48	4-95
Rear Drawbar:		
Pin Assembly .....	4-89	4-236
Replacement .....	4-88	4-235
Rear Junction Box:		
Repair .....	4-37	4-61
Replacement .....	4-36	4-59
Records, Maintenance .....	1-2	1-1

INDEX

Subject	Paragraph	Page
Redundant Power Kit:		
Fittings .....	4-111	4-305
Hose Assemblies.....	4-136	4-395
Operation .....	2-34	2-150
Reflectors .....	4-104	4-265
Regulator .....	4-129	4-380
Relay:		
Emergency Valve (Front Dolly) .....	4-62	4-140
Valve (Rear Dolly) .....	4-70	4-162
Repair Instructions, General Maintenance .....	4-14	4-9
Reports, Maintenance .....	1-2	1-1
Reservoir:		
Air:		
Draining .....	3-6	3-20
Replacement:		
Front Dolly .....	4-62	4-140
Rear Dolly .....	4-66	4-152
Hydraulic:		
Draining .....	4-111	4-305
Replacement .....	4-111	4-305
Rocker Arm Covers .....	4-117	4-337
Rough or Rocky Terrain, Operation on .....	2-31	2-146

S

Safety:		
Care and Handling .....	1-8	1-2
Chains:		
Mounting .....	4-52,	4-113
Replacement .....	4-51	4-111
Work .....	4-8	4-5
Saltwater, Operation in .....	2-28	2-145
Sandy Areas, Operation in .....	2-30	2-146
Schematics:		
Airbrake System .....	4-74	4-188
Hydraulic System .....	4-114	4-324
Seal, Oil, Cleaning .....	4-9d	4-7
Service Upon Receipt:		
Inspection Instructions .....	4-5	4-2
Servicing Instructions.....	4-6	4-3
Servicing Instructions, Service Upon Receipt .....	4-6	4-3
Shipment, Preparation of Equipment .....	4-145	4-405
Shock Absorber .....	4-102	4-260
Shutoff Valve:		
Mounting Bracket .....	4-68	4-158
Replacement .....	4-66	4-158
Side Cover .....	4-126	4-374

## INDEX

<i>Subject</i>	<i>Paragraph</i>	<i>Page</i>
Side Lift:		
Kit Installation .....	5-9	5-31
Operation Procedures:		
Attaching Dollies to Shelter:		
Shelter On Ground .....	2-12	2-84
Shelter On Trailer .....	2-13	2-92
Detaching Dollies:		
Shelter On Ground .....	2-16	2-110
Shelter On Trailer .....	2-15	2-103
Loading Shelter Onto Trailer .....	2-14	2-100
Lowering Dolly Set With Shelter .....	2-17	2-117
Raising Dolly Set With Shelter .....	2-14	2-100
Signal Conditioning Box:		
Cable Assembly .....	4-46	4-84
Circuit Breaker .....	4-34	4-49
Repair .....	4-34	4-49
Replacement .....	4-33	4-47
To Forward Junction Box Cable Assembly .....	4-46	4-84
Voltage Reducer .....	4-34	4-49
Snow, Operation in .....	2-24	2-143
Soldering .....	4-18	4-11
Specification Data .....	1-15	1-24
Spider Assembly .....	4-60	4-131
Spiral Case .....	4-128	4-378
Standard Operation Procedures:		
Attaching Dollies:		
To Each Other .....	2-10	2-67
To Shelter .....	2-9	2-59
Coupling Dolly Set to Towing Vehicle .....	2-11	2-76
Lowering Dolly Set .....	2-8	2-52
Raising Dolly Set .....	2-11	2-76
Uncoupling Dolly Set from Towing Vehicle .....	2-7	2-45
Starter:		
Replacement .....	4-130	4-382
Switch Assembly .....	4-131	4-384
Stator Assembly .....	4-116	4-332
Steam Cleaning .....	4-9b	4-6
Steering:		
Knuckle Assembly .....	4-54	4-116
Link .....	4-78	4-206
Principles of Operation .....	1-19	1-35
stop .....	4-79	4-209
Stencils, Location and Description .....	1-14	1-23
Stoplight-Taillight, Blackout .....	4-39	4-70

# INDEX

<i>Subject</i>	<i>Paragraph</i>	<i>Page</i>
Storage Box:		
Mounting Brackets .....	4-137	4-398
Replacement .....	4-138	4-399
Storage, Administrative:		
Airbrake System Valves .....	4-143	4-404
Definition .....	4-140	4-401
Equipment:		
Care .....	4-142	4-403
Preparation .....	4-141	4-401
Removal .....	4-144	4-404
Exercise Schedule .....	Table 4-3	4-404
Seals .....	4-143	4-404
Tires .....	4-143	4-404
Strainer, Fuel .....	4-124	4-362
Suspension:		
Link .....	5-5	5-9
Principles of Operation .....	1-20	1-37
■ Switch, Enclosure Assembly, Cold Start Kit .....	4-138.2	4-400.3
Switch Assembly, Starter .....	4-131	4-384
Symptom Index:		
Operator/Crew .....	3-5	3-10
Unit .....	4-32	4-27

## T

Tagging:		
Hoses .....	4-18	4-11
Wires .....	4-18	4-11
Taillight Assembly:		
Cable Assembly .....	4-48	4-95
Housing .....	4-41	4-74
Maintenance .....	4-40	4-72
Tandem Towing .....	2-19	2-122
Tape, Antiseize, General Maintenance .....	4-24	4-13
Telescopic Brace .....	4-86	2-32
Terrain, Operation on:		
Rocky .....	2-31	2-146
Rough .....	2-31	2-146
Uneven .....	2-32	2-146
Tie-rod Assembly .....	4-77	4-201
Tire and Wheel:		
Lowering to Ground .....	2-21e	2-137
Raising Off Ground .....	2-21d	2-135
Tire:		
Maintenance .....	4-76	4-197
Preparation for Storage .....	4-143	4-404
Repair .....	5-4	5-8
Tool Requirements, Standard .....	4-17	4-10

**INDEX**

Subject	Paragraph	Page
Toolbox:		
Mounting Bracket .....	4-97	4-247
Replacement .....	4-103	4-263
Top Beam.. .....	4-83	4-222
Top Hook .....	4-84	4-229
Towing:		
Instructions, General .....	2-18	2-120
Tandem .....	2-19	2-122
Transportation Lockout .....	4-85	4-230
Troubleshooting:		
Operator/Crew .....	3-3	3-9
Symptom Index:		
Operator/Crew .....	3-5	3-10
Unit .....	4-32	4-27
Unit .....	4-30	4-26
Tubing, Heat Shrinkable .....	4-20	4-11

**U**

Uncaging Brakes.. .....	4-56	4-121
Uncoupling Dolly Set from Towing Vehicle .....	2-7	2-45
Uneven Terrain, Operation on .....	2-32	2-146
Unit:		
PMCS .....	4-27	4-16
Troubleshooting .....	4-30	4-26
Upper Bracket .....	4-98	4-248

**V**

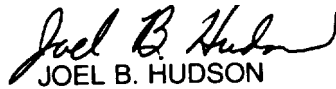
Valve:		
Airbrake:		
Preparation for Storage .....	4-143	4-404
Replacement .....	4-65	4-148
Booster Relay:		
Front Dolly.. .....	4-63	4-144
Rear Dolly.. .....	4-67	4-156
Full Function.. .....	4-66	4-152
Hydraulic Control:		
Repair .....	5-6	5-15
Replacement:		
Front Dolly .....	4-108	4-274
Rear Dolly .....	4-108	4-274
Parking Brake .....	4-69	4-160
Pressure Protection .....	4-64	4-146
Relay Emergency.. .....	4-62	4-140
Relay .....	4-70	4-162
Shutoff.. .....	4-68	4-158

INDEX

Subject	Paragraph	Page
Voltage Reducer (Signal Conditioning Box) .....	4-34	4-49
<b>W</b>		
Warranty Data .....	1-7	1-2
Wheel and Tire:		
Lowering to Ground .....	2-21e	2-137
Raising Off Ground .....	2-21d	2-135
Wheel Bearing:		
Adjustment .....	4-75	4-191
Maintenance.. .....	4-75	4-191
Wheel:		
Alinement .....	4-77	4-201
Maintenance.. .....	4-76	4-197
Winterizing Engine Below 0°F (-18°C) .....	4-134	4-392
Wires, Tagging .....	4-18	4-11
Wiring Diagram:		
Electrical .....	4-50	4-108
Engine.. .....	4-135	4-394
Wiring Harness, Engine.. .....	4-132	4-386
Work Safety .....	4-8	4-5

By Order of the Secretary of the Army:

Official:



Handwritten signature of Joel B. Hudson in black ink.

JOEL B. HUDSON

*Administrative Assistant to the  
Secretary of the Army*  
02446

DENNIS J. REIMER  
*General, United States Army  
Chief of Staff*

DISTRIBUTION:

To be distributed in accordance with the initial distribution number (IDN) 391016,  
requirements for TM 9-2330-390-14&P.





<b>RECOMMENDED CHANGES TO PUBLICATIONS AND BLANK FORMS</b>						Use Part II ( <i>reverse</i> ) for Repair Parts and Special Tool Lists (RPSTL) and Supply Catalogs/Supply Manuals (SC/SM).	DATE
For use of this form, see AR 25-30; the proponent agency is ODISC4.							
TO: ( <i>Forward to proponent of publication or form</i> ) ( <i>Include ZIP Code</i> ) AMSTA-LC-LPIT / TECH PUBS, TACOM-RI 1 Rock Island Arsenal Rock Island, IL 61299-7630						FROM: ( <i>Activity and location</i> ) ( <i>Include ZIP Code</i> )	
<b>PART I - ALL PUBLICATIONS (EXCEPT RPSTL AND SC/SM) AND BLANK FORMS</b>							
PUBLICATION/FORM NUMBER TM 9-2330-390-14&P					DATE 1 April 1996	TITLE M1022A1Transportable Shelter Dolly Set	
ITEM NO.	PAGE NO.	PARA-GRAPH	LINE NO. *	FIGURE NO.	TABLE NO.	RECOMMENDED CHANGES AND REASON ( <i>Provide exact wording of recommended changes, if possible.</i> )	
<i>*Reference to line numbers within the paragraph or subparagraph.</i>							
TYPED NAME, GRADE OR TITLE					TELEPHONE EXCHANGE/AUTOVON, PLUS EXTENSION		SIGNATURE

TO: <i>(Forward direct to addressee listed in publication)</i> AMSTA-LC-LPIT / TECH PUBS, TACOM-RI 1 Rock Island Arsenal Rock Island, IL 61299-7630	FROM: <i>(Activity and location) (Include ZIP Code)</i>	DATE
--	---	------

**PART II - REPAIR PARTS AND SPECIAL TOOL LISTS AND SUPPLY CATALOGS/SUPPLY MANUALS**

PUBLICATION NUMBER TM 9-2330-390-14&P	DATE 1 April 1996	TITLE M1022A1 Transportable Shelter Dolly Set
--	----------------------	--

PAGE NO.	COLM NO.	LINE NO.	NATIONAL STOCK NUMBER	REFERENCE NO.	FIGURE NO.	ITEM NO.	TOTAL NO. OF MAJOR ITEMS SUPPORTED	RECOMMENDED ACTION

**PART III - REMARKS** *(Any general remarks or recommendations, or suggestions for improvement of publications and blank forms. Additional blank sheets may be used if more space is needed.)*

--

TYPED NAME, GRADE OR TITLE	TELEPHONE EXCHANGE/AUTOVON, PLUS EXTENSION	SIGNATURE
----------------------------	--	-----------

<b>RECOMMENDED CHANGES TO PUBLICATIONS AND BLANK FORMS</b> For use of this form, see AR 25-30; the proponent agency is ODISC4.						Use Part II ( <i>reverse</i> ) for Repair Parts and Special Tool Lists (RPSTL) and Supply Catalogs/Supply Manuals (SC/SM).	DATE
TO: ( <i>Forward to proponent of publication or form</i> ) ( <i>Include ZIP Code</i> ) AMSTA-LC-LPIT / TECH PUBS, TACOM-RI 1 Rock Island Arsenal Rock Island, IL 61299-7630						FROM: ( <i>Activity and location</i> ) ( <i>Include ZIP Code</i> )	
<b>PART I - ALL PUBLICATIONS (EXCEPT RPSTL AND SC/SM) AND BLANK FORMS</b>							
PUBLICATION/FORM NUMBER TM 9-2330-390-14&P						DATE 1 April 1996	TITLE M1022A1Transportable Shelter Dolly Set
ITEM NO.	PAGE NO.	PARA-GRAPH	LINE NO. *	FIGURE NO.	TABLE NO.	RECOMMENDED CHANGES AND REASON ( <i>Provide exact wording of recommended changes, if possible.</i> )	
<i>*Reference to line numbers within the paragraph or subparagraph.</i>							
TYPED NAME, GRADE OR TITLE					TELEPHONE EXCHANGE/AUTOVON, PLUS EXTENSION		SIGNATURE

TO: <i>(Forward direct to addressee listed in publication)</i> AMSTA-LC-LPIT / TECH PUBS, TACOM-RI 1 Rock Island Arsenal Rock Island, IL 61299-7630	FROM: <i>(Activity and location) (Include ZIP Code)</i>	DATE
--	---	------

**PART II - REPAIR PARTS AND SPECIAL TOOL LISTS AND SUPPLY CATALOGS/SUPPLY MANUALS**

PUBLICATION NUMBER TM 9-2330-390-14&P	DATE 1 April 1996	TITLE M1022A1Transportable Shelter Dolly Set
--	----------------------	--

PAGE NO.	COLM NO.	LINE NO.	NATIONAL STOCK NUMBER	REFERENCE NO.	FIGURE NO.	ITEM NO.	TOTAL NO. OF MAJOR ITEMS SUPPORTED	RECOMMENDED ACTION

**PART III - REMARKS** *(Any general remarks or recommendations, or suggestions for improvement of publications and blank forms. Additional blank sheets may be used if more space is needed.)*

--

TYPED NAME, GRADE OR TITLE	TELEPHONE EXCHANGE/AUTOVON, PLUS EXTENSION	SIGNATURE
----------------------------	--	-----------

**THE METRIC SYSTEM AND EQUIVALENTS**

**LINEAR MEASURE**

1 Centimeter=10 Millimeters=0.01 Meters=0.3937 Inches  
 1 Meter=100 Centimeters=1000 Millimeters=39.37 Inches  
 1 Kilometer=1000 Meters=0.621 Miles

**WEIGHTS**

1 Gram=0.001 Kilograms=1000 Milligrams=0.035 Ounces  
 1 Kilogram=1000 Grams=2.2 Lb  
 1 Metric Ton=1000 Kilograms=1 Megagram=1.1 Short Tons

**LIQUID MEASURE**

1 Milliliter=0.001 Liters=0.0338 Fluid Ounces  
 1 Liter=1000 Milliliters=33.82 Fluid Ounces

**SQUARE MEASURE**

1 Sq Centimeter=100 Sq Millimeters=0.155 Sq Inches  
 1 Sq Meter=10,000 Sq Centimeters=10.76 Sq Feet  
 1 Sq Kilometer=1,000,000 Sq Meters=0.386 Sq Miles

**CUBIC MEASURE**

1 Cu Centimeter=1000 Cu Millimeters=0.06 Cu Inches  
 1 Cu Meter=1,000,000 Cu Centimeters=35.31 Cu Feet

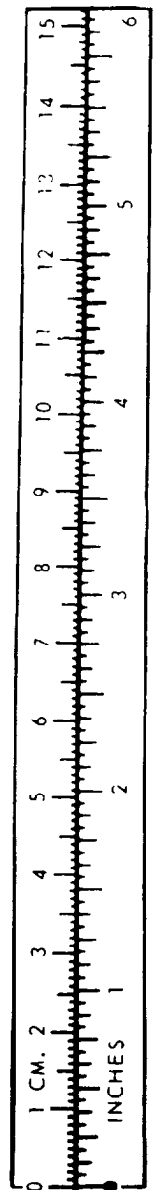
**TEMPERATURE**

$5/9 (°F - 32) = °C$   
 212° Fahrenheit is equivalent to 100° Celsius  
 90° Fahrenheit is equivalent to 32.2° Celsius  
 32° Fahrenheit is equivalent to 0° Celsius  
 $9/5 C° + 32 = F°$

**APPROXIMATE CONVERSION FACTORS**

<u>TO CHANGE</u>	<u>TO</u>	<u>MULTIPLY BY</u>
Inches . . . . .	Centimeters . . . . .	2.540
Feet . . . . .	Meters . . . . .	0.305
Yards . . . . .	Meters . . . . .	0.914
Miles . . . . .	Kilometers . . . . .	1.609
Square Inches . . . . .	Square Centimeters . . . . .	6.451
Square Feet . . . . .	Square Meters . . . . .	0.093
Square Yards . . . . .	Square Meters . . . . .	0.836
Square Miles . . . . .	Square Kilometers . . . . .	2.590
Acres . . . . .	Square Hectometers . . . . .	0.405
Cubic Feet . . . . .	Cubic Meters . . . . .	0.028
Cubic Yards . . . . .	Cubic Meters . . . . .	0.765
Fluid Ounces . . . . .	Milliliters . . . . .	29.573
Pints . . . . .	Liters . . . . .	0.473
Quarts . . . . .	Liters . . . . .	0.946
Gallons . . . . .	Liters . . . . .	3.785
Ounces . . . . .	Grams . . . . .	28.349
Pounds . . . . .	Kilograms . . . . .	0.454
Short Tons . . . . .	Metric Tons . . . . .	0.907
Pound-Feet . . . . .	Newton-Meters . . . . .	1.356
Pounds per Square Inch . . . . .	Kilopascals . . . . .	6.895
Miles per Gallon . . . . .	Kilometers per Liter . . . . .	0.425
Miles per Hour . . . . .	Kilometers per Hour . . . . .	1.609

<u>TO CHANGE</u>	<u>TO</u>	<u>MULTIPLY BY</u>
Centimeters . . . . .	Inches . . . . .	0.394
Meters . . . . .	Feet . . . . .	3.280
Meters . . . . .	Yards . . . . .	1.094
Kilometers . . . . .	Miles . . . . .	0.621
Square Centimeters . . . . .	Square Inches . . . . .	0.155
Square Meters . . . . .	Square Feet . . . . .	10.764
Square Meters . . . . .	Square Yards . . . . .	1.196
Square Kilometers . . . . .	Square Miles . . . . .	0.386
Square Hectometers . . . . .	Acres . . . . .	2.471
Cubic Meters . . . . .	Cubic Feet . . . . .	35.315
Cubic Meters . . . . .	Cubic Yards . . . . .	1.308
Milliliters . . . . .	Fluid Ounces . . . . .	0.034
Liters . . . . .	Pints . . . . .	2.113
Liters . . . . .	Quarts . . . . .	1.057
Liters . . . . .	Gallons . . . . .	0.264
Grams . . . . .	Ounces . . . . .	0.035
Kilograms . . . . .	Pounds . . . . .	2.205
Metric Tons . . . . .	Short Tons . . . . .	1.102
Newton-Meters . . . . .	Pound-Feet . . . . .	0.738
Kilopascals . . . . .	Pounds per Square Inch . . . . .	0.145
Kilometers per Liter . . . . .	Miles per Gallon . . . . .	2.354
Kilometers per Hour . . . . .	Miles per Hour . . . . .	0.621



TAO89991

(FOR REFERENCE ONLY)

